



COMPOMAC

CONEX

forniture
per
l'industria
gelmini s.r.l.

forniture per l'industria gelmini s.r.l.

Sede: Parma – Via Cerati 3/A – tel. 0521.993844 fax 0521.291688

Filiale: Guidizzolo (MN) – Via Tiziano, 11 – tel. 0376.847123 fax 0376.840319

www.fornituregelmini.it mail: info@fornituregelmini.it



CONEX A

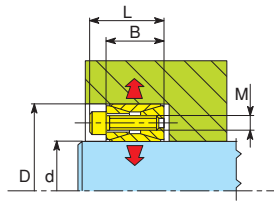

NON AUTOCENTRANTE -
COPPIE MEDIO-ALTE
NOT SELF CENTERING -
MEDIUM-HIGH TORQUES
PAS D'EFFET DE - CENTRAGE
COUPLES MOYENS

CONEX SD - Shrink Disc

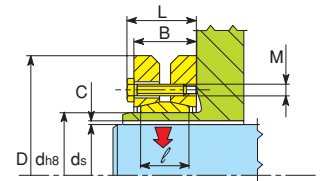

BLOCCO DALL'ESTERNO -
CENTRICITÀ OTTIMA
EXTERNAL CLAMPING -
EXCELLENT CONCENTRICITY
SERRAGE EXTÉRIEUR - TRÈS
BON CENTRAGE

CONEX A					Ts Nm	T Nm	F kN	P N/mm ²
d mm	D mm	B mm	L mm	M mm				
17	47	20	26	M 6	16	230	28	92
18	47	20	26	M 6	16	250	28	92
19	47	20	26	M 6	16	260	28	92
20	47	20	26	M 6	16	280	28	92
22	47	20	26	M 6	16	310	28	92
24	50	20	26	M 6	16	360	31	95
25	50	20	26	M 6	16	380	31	95
28	55	20	26	M 6	16	580	42	118
30	55	20	26	M 6	16	630	42	118
32	60	20	26	M 6	16	670	42	110
35	60	20	26	M 6	16	730	42	110
38	65	20	26	M 6	16	990	52	125
40	65	20	26	M 6	16	1040	52	125
42	75	24	32	M 8	38	1600	76	140
45	75	24	32	M 8	38	1700	76	140
48	80	24	32	M 8	38	1800	76	120
50	80	24	32	M 8	38	1900	76	130
55	85	24	32	M 8	38	2600	95	150
60	90	24	32	M 8	38	2850	95	140
65	95	24	32	M 8	38	3100	95	130
70	110	28	38	M 10	75	5350	150	160
75	115	28	38	M 10	75	5730	150	150
80	120	28	38	M 10	75	6100	150	140
85	125	28	38	M 10	75	6500	150	140
90	130	28	38	M 10	75	6900	150	130
95	135	28	38	M 10	75	8700	180	150
100	145	32	44	M 12	130	11200	220	160
110	155	32	44	M 12	130	12300	220	150
120	165	32	44	M 12	130	14300	240	150
130	180	38	50	M 12	130	19400	300	130
140	190	38	50	M 12	130	23000	330	140
150	200	38	50	M 12	130	26900	360	140
160	210	38	50	M 12	130	31000	390	150
170	225	44	58	M 14	200	36300	430	140
180	235	44	58	M 14	200	42000	470	140
190	250	52	66	M 14	200	51800	550	130
200	260	52	66	M 14	200	58300	590	130
220	285	56	72	M 16	300	74100	680	130
240	305	56	72	M 16	300	93200	780	140
260	325	56	72	M 16	300	114500	890	150
280	355	66	84	M 18	410	141000	1000	130
300	375	66	84	M 18	410	170000	1140	140
320	405	78	98	M 20	590	235500	1500	140
340	425	78	98	M 20	590	250000	1500	130
360	455	90	112	M 22	790	329000	1800	130
380	475	90	112	M 22	790	346400	1800	120
400	495	90	112	M 22	790	365000	1800	120
420	515	90	116	M 22	790	397000	1890	122
440	545	102	130	M 24	1050	468000	2130	120
460	565	102	130	M 24	1050	489000	2130	115

T_s (Nm)	Coppia di serraggio viti	<i>Screws tightening torque</i>	Couple de serrage des vis
T_N (Nm)	Coppia di serraggio ghiera	<i>Nut setting torque</i>	Couple de serrage de l'écrou
T (Nm)	Coppia massima o forza	<i>Pick torque or axial</i>	Couple maxime ou effort
F (kN)	assiale trasmissibili con coppia di serraggio viti T _s	<i>force transmissible with tightening torque T_s</i>	axial transmissible avec le couple de serrage T _s
p (N/mm ²)	Pressione superficiale sul mezzo	<i>Hub surface pressure</i>	Pression de contact sur l'alésage

CONEX SD								Ts Nm	T Nm	F kN
d mm	ds mm	D mm	L mm	B mm	mm	C max	M mm			
14	10-11-12	38	15	11	9	0,014	M 5	3,5	28-38-50	5-7-9
16	12-13-14	41	19	15	11	0,014	M 5	4	50-70-90	9-10-13
18	14-15-16	44	19	15	12	0,014	M 5	4	85-100-130	16-18-20
20	15-16-18	50	23	19	14	0,017	M 5	4	130-150-200	20-22-25
21	16-17-18	50	23	19	14	0,017	M 5	5	170-210-250	29-33-35
24	19-20-21	50	23	19	14	0,017	M 5	5	180-210-250	26-27-29
30	24-25-26	60	25	21	16	0,017	M 5	6	310-340-380	26-27-28
36	28-30-31	72	27	23	18	0,017	M 6	12	460-590-630	50-54-58
44	32-35-36	80	29	25	20	0,032	M 6	12	630-780-860	65-74-77
50	38-40-42	90	31	27	22	0,032	M 6	12	940-1100-1300	79-85-90
55	42-45-48	100	34	30	23	0,032	M 6	12	1200-1500-1900	80-90-100
62	48-50-52	110	34	30	23	0,032	M 6	12	1800-2200-2400	100-110-120
68	50-55-60	115	34	30	23	0,038	M 6	12	2000-2500-3100	100-110-120
75	55-60-65	138	38	32	25	0,048	M 8	30	2500-3200-3900	120-140-150
80	60-65-70	145	38	32	25	0,048	M 8	30	3200-3900-4600	120-140-160
90	65-70-75	155	45	39	30	0,048	M 8	30	4700-6000-7200	170-190-210
100	70-75-80	170	49,5	44	34	0,048	M 8	30	6900-7500-9000	180-220-240
110	75-80-85	185	57	50	39	0,048	M 10	59	7200-9000-11000	230-250-260
115	80-85-90	188	57	50	39	0,048	M 10	59	8500-10000-12000	210-240-270
120	80-85-90	215	61	52	42	0,048	M 10	59	10500-13200-14400	280-300-330
125	85-90-95	215	61	52	42	0,056	M 10	59	11000-13000-15000	300-320-350
130	90-95-100	215	59	52	42	0,056	M 10	59	13700-15800-18200	300-330-360
140	95-100-105	230	68	60	46	0,056	M 12	100	15000-17000-20000	360-400-420
155	105-110-115	265	72	64	50	0,069	M 12	100	20000-23000-26000	390-420-450
160	110-115-120	265	72	64	50	0,069	M 12	100	22500-25500-28600	450-480-510
165	115-120-125	290	81	71	56	0,069	M 16	250	36000-39000-44000	630-660-700
170	120-125-130	290	81	71	56	0,079	M 16	250	31700-35800-40000	600-630-660
175	125-130-135	300	81	71	56	0,079	M 16	250	40000-44000-49000	650-680-720
180	130-135-140	300	81	71	56	0,079	M 16	250	36800-42000-46000	800-830-870
185	135-140-145	330	96	86	71	0,079	M 16	250	55000-60000-65000	815-875-896
190	140-145-150	330	96	86	71	0,079	M 16	250	53300-58500-63500	790-830-870
195	140-150-155	350	96	86	71	0,079	M 16	250	66000-76000-82000	950-1000-1100
200	150-155-160	350	96	86	71	0,079	M 16	250	73700-79800-85800	980-1000-1070
220	160-165-170	370	114	104	88	0,079	M 16	250	95000-102000-110000	1200-1300-1300
240	170-180-190	405	121	108	92	0,079	M 20	490	120000-140000-160000	1500-1600-1700
250	180-190-200	405	121	108	92	0,090	M 20	490	160000-180000-200000	1600-1700-1800
260	190-200-210	430	133	120	103	0,090	M 20	490	165000-185000-204000	1760-1878-2008
280	210-220-230	460	147	134	114	0,090	M 20	490	216000-245000-270000	2085-2220-2350
300	230-240-245	485	155	142	122	0,090	M 20	490	274000-296000-316000	2430-2560-2630
320	240-250-260	520	155	142	122	0,101	M 20	490	311000-340000-375000	2640-2780-2900
330	250-260-270	520	155	142	122	0,101	M 20	490	352000-385000-420000	2800-2900-3100
340	250-260-270	570	169	156	134	0,101	M 20	490	389000-422000-459000	3115-3245-3400
350	270-280-285	580	175	162	140	0,101	M 20	490	443000-480000-500000	3275-3430-3500
360	280-290-300	580	175	162	140	0,101	M 20	490	462000-500000-530000	3300-3460-3600

Grandezze superiori su richiesta - Larger sizes upon request - Tailles plus grandes sur demande

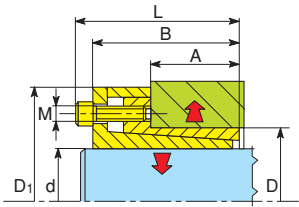
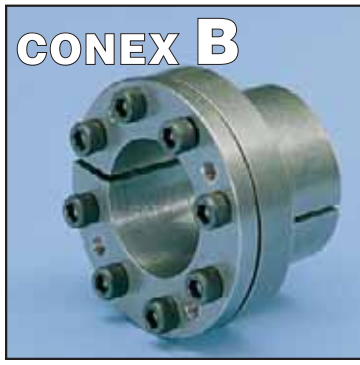

**AUTOCENTRANTE
PICCOLO INGOMBRO RADIALE
SELF CENTERING FOR
THIN WALLED HUBS
EFFET DE CENTRAGE
DIMENSIONS RADIALES RÉDUITES**

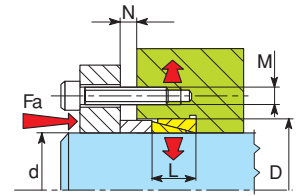

**NON AUTOCENTRANTE
PICCOLO INGOMBRO RADIALE
NOT SELF CENTERING
SMALL RADIAL DIMENSIONS
PAS D'EFFET DE CENTRAGE
DIMENSIONS RADIALES RÉDUITES**

CONEX B							Ts Nm	T Nm	F kN	P N/mm ²
d mm	D mm	D ₁ mm	A mm	B mm	L mm	M mm				
6	14	25	10	21	24	M 3	2,6	11	3,8	68
8	15	27	11,5	25	29	M 4	5,6	26	6,5	98
9	16	28	14	26	30	M 4	5,6	37	8	98
10	16	29	14	26	30	M 4	5,6	42	8	98
11	18	32	13,5	26	30	M 4	5,6	50	9	100
12	18	32	13,5	26	30	M 4	5,6	55	9	100
14	23	38	14	26	30	M 4	5,6	64	9	75
15	24	44	16	36	42	M 6	15	145	19	130
16	24	44	16	36	42	M 6	15	155	19	130
17	25	45	16	36	42	M 6	15	162	19	125
17	26	47	18	38	44	M 6	17	180	23	122
18	26	47	18	38	44	M 6	17	200	23	120
19	27	48	18	38	44	M 6	17	210	23	120
20	28	49	18	38	44	M 6	17	220	23	120
22	32	54	25	45	51	M 6	17	250	23	70
24	34	56	25	45	51	M 6	17	270	23	70
25	34	56	25	45	51	M 6	17	280	23	70
28	39	61	25	45	51	M 6	17	480	34	90
30	41	62	25	45	51	M 6	17	510	34	84
32	43	65	25	45	51	M 6	17	730	46	115
35	47	69	30	50	56	M 6	17	800	46	81
38	50	72	30	50	56	M 6	17	860	46	76
40	53	75	30	50	56	M 6	17	900	46	72
42	55	78	32	57	65	M 8	41	1800	84	125
45	59	85	40	65	73	M 8	41	1900	84	89
48	62	87	45	70	78	M 8	41	2000	84	75
50	65	92	45	70	78	M 8	41	2600	105	90
55	71	98	50	75	83	M 8	41	2900	105	70
60	77	104	50	75	83	M 8	41	3100	105	70
65	84	111	50	75	83	M 8	41	3400	105	60
70	90	119	60	91	101	M 10	83	5800	170	80
75	95	126	60	91	101	M 10	83	6200	170	70
80	100	131	65	96	106	M 10	83	8000	200	80
85	106	137	65	96	106	M 10	83	8500	200	70
90	112	143	65	96	106	M 10	83	11200	250	90
95	120	153	65	96	106	M 10	83	11800	250	80
100	125	162	65	102	114	M 12	145	14600	300	95
110	140	180	90	128	140	M 12	145	16000	300	61
120	155	198	90	128	140	M 12	145	17400	300	55

I Conex B da d = 6 fino a d = 14 raggiungono le piene coppie trasmissibili solo lubrificando le superfici coniche e le viti con olii contenenti additivi per alte pressioni (M₀S₂).

Conex B from d = 6 up to d = 14 can transmit the full transmissible torque only oiling the conical surfaces and the screws with oils with high pressure additives (M₀S₂).

Conex B d = 6 jusqu'à d = 14 peuvent transmettre le couple maximale seulement huileant les surfaces coniques et les vis avec huiles avec additives pour hautes pressions (M₀S₂).

F_A Forza di precarico: è data dal numero di viti sulla flangia, strette alla coppia T_s. Ogni vite produce la forza F_s e il numero di viti sarà n · F_s = F_A. Applicando la forza di precarico F_A, è possibile trasmettere la coppia T o lo sforzo assiale F.

F_A Preload force. It is produced by the nr. of screws on the flange, tightened with the torque T_s. Every screw produces the force F_s, and the number of screws should be: n · F_s = F_A. The preload force F_A generates the transmissible torque T or axial force F.

F_A Force de précontrainte. Cette force résulte de l'effort induit par les n vis, serrée chacune avec un couple T_s. Chaque vis produit un effort F_s, ainsi la force total est F_A = n · F_s. Cette force de précontrainte permet de transmettre un couple (T) ou un effort axial (F).

CONEX C							T Nm	F kN	p N/mm ²	F _A kN	
d mm	D mm	L mm	1	2	N	3					4
6	9	4,5	3	3	3	3	4	2	0,8	75	4
7	10	4,5	3	3	3	3	4	4	1	84	5
8	11	4,5	3	3	3	3	4	5	1	90	6
9	12	4,5	3	3	3	3	4	8	1,6	95	15
10	13	4,5	3	3	3	3	4	10	2	100	16
12	15	4,5	3	3	3	3	4	11	2	90	16
13	16	4,5	3	3	3	3	4	13	2,1	105	16
14	18	6,3	3	4	4	4	5	22	3	90	26
15	19	6,3	3	4	4	4	5	25	3	90	27
16	20	6,3	3	4	4	4	5	26	3	90	27
17	21	6,3	3	4	4	4	5	30	3	90	27
18	22	6,3	3	4	4	4	5	33	3	90	33
19	24	6,3	3	4	4	4	5	40	4	90	33
20	25	6,3	3	4	4	4	5	44	4	90	33
22	26	6,3	3	4	4	4	5	50	4	90	34
24	28	6,3	3	4	4	4	5	68	6	100	34
25	30	6,3	3	4	4	4	5	75	6	100	37
28	32	6,3	3	4	4	4	5	90	6	100	40
30	35	6,3	3	4	4	4	5	100	7	100	40
32	36	6,3	3	4	4	4	5	120	7	100	44
35	40	7	3	4	4	4	5	160	9	100	54
36	42	7	4	5	5	6	6	170	9,5	100	57
38	44	7	4	5	5	6	6	190	10	100	60
40	45	8	4	5	5	6	6	230	11	100	70
42	48	8	4	5	5	6	6	260	12	100	75
45	52	10	4	5	5	6	6	390	17	100	110
48	55	10	4	5	5	6	6	430	18	100	110
50	57	10	4	5	5	6	6	470	19	100	110
55	62	10	4	5	5	6	6	580	21	100	120
56	64	12	4	5	5	6	6	740	24	100	150
60	68	12	4	5	6	7	7	840	28	100	160
63	71	12	4	5	6	7	7	920	29	100	170
65	73	12	4	5	6	7	7	1000	30	100	170
70	79	14	4	5	6	7	7	1300	38	100	210
71	80	14	4	5	6	7	7	1400	39	100	220
75	84	14	4	5	6	7	7	1500	41	100	230
80	91	17	5	6	7	8	8	2100	54	100	300
85	96	17	5	6	7	8	8	2400	57	100	320
90	101	17	5	6	7	8	8	2700	61	100	330
95	106	17	5	6	8	9	9	3000	64	100	340
100	114	21	5	6	8	9	9	4200	84	100	460
110	124	21	5	6	8	9	9	4700	86	90	475
120	134	21	5	6	8	9	9	5100	88	90	475
130	148	28	6	7	9	11	11	8100	125	90	700
140	158	28	6	7	9	11	11	9400	135	90	740
150	168	28	6	7	9	11	11	11000	145	90	790
160	178	28	6	7	9	11	11	14500	180	105	950
170	191	33	7	8	10	12	12	19500	228	105	1180
180	201	33	7	8	10	12	12	21200	235	105	1200
190	211	33	7	9	10	12	12	24100	250	110	1300
200	224	38	7	9	11	13	13	31000	310	105	1600

MONTAGGI IN SERIE DI PIÙ UNITÀ
ASSEMBLY IN SERIES OF MORE UNITS
MONTAGE EN SÉRIE DE PLUSIEURS PIÈCES

2 CONEX C T₂ = T x 1,6
3 CONEX C T₃ = T x 1,9
4 CONEX C T₄ = T x 2,1

Viti tipo Screw size Diam. vis	T _s Nm	F _s kN
M 6	10	9
M 8	26	16
M 10	49	26
M 12	85	38
M 14	135	52



CONEX DS (short)

CONEX D

CONEX ES (short)

CONEX E

CONEX DS - CONEX ES

d mm	D mm	D ₁ mm	A mm	B mm	L mm	M mm
18	47	53	22	28	34	M 6
19	47	53	22	28	34	M 6
20	47	53	22	28	34	M 6
22	47	53	22	28	34	M 6
24	50	56	22	28	34	M 6
25	50	56	22	28	34	M 6
28	55	61,4	22	28	34	M 6
30	55	61,4	22	28	34	M 6
32	60	67	22	28	34	M 6
35	60	67	22	28	34	M 6
38	65	72	22	28	34	M 6
40	65	72	22	28	34	M 6
42	75	84	25	33	41	M 8
45	75	84	25	33	41	M 8
48	80	89	24	33,5	41	M 8
50	80	89	24	33,5	41	M 8
55	85	94	24	33,5	41	M 8
60	90	99	24	33,5	41	M 8
65	95	104	24	33,5	41	M 8
70	110	119	29	40	50	M 10
75	115	124	29	40	50	M 10
80	120	129	29	40	50	M 10
85	125	134	29	40	50	M 10
90	130	139	29	40	50	M 10
95	135	144	29	40	50	M 10
100	145	154	31	44	56	M 12
110	155	164	31	44	56	M 12
120	165	174	31	44	56	M 12
130	180	189	39	52	64	M 12
140	190	199	39	54	68	M 14
150	200	209	39	54	68	M 14
160	210	219	39	54	68	M 14
180	235	244	49	64	78	M 14
200	260	269	49	64	78	M 14

CONEX DS

Ts Nm	T Nm	F kN	P N/mm ²
14	370	41	140
14	390	41	140
14	410	41	140
14	450	41	140
14	490	41	130
14	510	41	130
14	570	41	120
14	610	41	120
14	880	55	145
14	960	55	145
14	1000	55	135
14	1100	55	135
35	2200	105	190
35	2400	105	190
35	2500	105	175
35	2600	105	175
35	2900	105	165
35	3100	105	155
35	3400	105	150
70	6000	170	175
70	6400	170	170
70	6800	170	160
70	9000	210	190
70	9600	210	185
70	10200	210	185
115	12000	235	170
115	13000	260	160
115	16000	270	165
115	23000	350	155
185	25000	360	150
185	30000	400	155
185	38800	480	170
—	—	—	—
—	—	—	—

CONEX ES

Ts Nm	T Nm	F kN	P N/mm ²
17	290	32	100
17	300	32	100
17	320	32	100
17	350	32	100
17	390	32	100
17	400	32	100
17	450	32	90
17	490	32	90
17	700	43	110
17	760	43	110
17	820	43	100
17	870	43	100
41	1700	80	140
41	1800	80	140
41	1900	80	130
41	2000	80	130
41	2200	80	120
41	2400	80	120
41	2600	80	110
83	4600	130	130
83	5000	130	130
83	5300	130	120
83	7000	160	150
83	7400	160	140
83	7800	160	130
145	9700	200	140
145	10700	200	130
145	13100	220	150
145	19000	290	130
230	20500	300	140
230	24500	330	130
230	31300	390	150
230	35000	390	100
230	49000	500	110

CONEX DS - CONEX D

AUTOCENTRANTE - COPPIE TRASMISSIBILI ALTE (durante il bloccaggio il pezzo può spostarsi assialmente)

SELF CENTERING - HIGH TRANSMISSIBLE TORQUE (during the clamping the hub can axially displace)

EFFET DE CENTRAGE - COUPLE TRANSMISSIBLE ÉLEVÉ (pendant le blocage le moyeu peut se déplacer axialement)

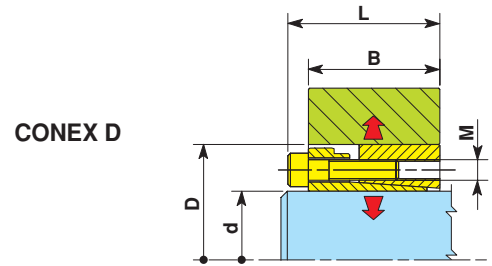
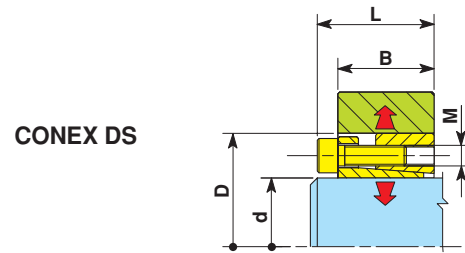

CONEX D - CONEX E

d mm	D mm	D ₁ mm	A mm	B mm	L mm	M mm
20	47	53	31	42	48	M 6
22	47	53	31	42	48	M 6
24	50	56	31	42	48	M 6
25	50	56	31	42	48	M 6
28	55	61	31	42	48	M 6
30	55	61	31	42	48	M 6
32	60	66	31	42	48	M 6
35	60	66	31	42	48	M 6
38	65	71	31	42	48	M 6
40	65	71	31	42	48	M 6
42	75	81	35	51	59	M 8
45	75	81	35	51	59	M 8
48	80	86	35	51	59	M 8
50	80	86	35	51	59	M 8
55	85	91	35	51	59	M 8
60	90	96	35	51	59	M 8
65	95	101	35	51	59	M 8
70	110	119	45	60	70	M 10
75	115	124	45	60	70	M 10
80	120	129	45	60	70	M 10
85	125	134	45	60	70	M 10
90	130	139	45	60	70	M 10
95	135	144	46	60	70	M 10
100	145	155	52	68	80	M 12
110	155	165	52	68	80	M 12
120	165	175	52	68	80	M 12
130	180	188	52	68	80	M 12
140	190	199	58	76	90	M 14
150	200	209	58	76	90	M 14
160	210	219	58	76	90	M 14
170	225	234	58	76	90	M 14
180	235	244	58	76	90	M 14

CONEX D

Ts Nm	T Nm	F kN	P N/mm ²
17	530	52	110
17	580	52	110
17	630	52	100
17	660	52	100
17	740	52	100
17	790	52	100
17	1150	70	120
17	1300	70	120
17	1300	70	110
17	1400	70	110
41	2000	100	120
41	2200	100	120
41	3200	130	150
41	3300	130	150
41	3600	130	140
41	3900	130	130
41	4300	130	120
83	7500	210	130
83	8000	210	130
83	8500	210	120
83	11400	270	150
83	12000	270	140
83	12600	280	135
145	15000	300	130
145	16500	300	120
145	22500	370	140
145	29000	450	150
210	32000	460	130
210	41000	550	150
210	44000	550	140
210	54500	640	160
210	57500	640	150

CONEX E

Ts Nm	T Nm	F kN	P N/mm ²
17	320	33	70
17	360	33	70
17	390	33	70
17	400	33	70
17	450	33	60
17	490	33	60
17	690	43	70
17	750	43	70
17	820	43	70
17	860	43	70
41	1300	60	70
41	1400	60	70
41	1900	80	90
41	2000	80	90
41	2200	80	90
41	2400	80	80
41	2600	80	70
83	4600	130	80
83	5000	130	80
83	5200	130	70
83	7000	170	90
83	7400	170	80
83	7800	170	80
145	9800	190	80
145	10700	190	70
145	14600	240	90
145	19000	300	100
230	23000	330	90
230	30000	400	100
230	32000	400	100
230	39000	460	110
230	41000	460	100

CONEX ES - CONEX E

AUTOCENTRANTE (il mozzo rimane fisso assialmente)

SELF CENTERING (during the clamping the hub remains axially fixed)

EFFET DE CENTRAGE (positionnement axial précis)

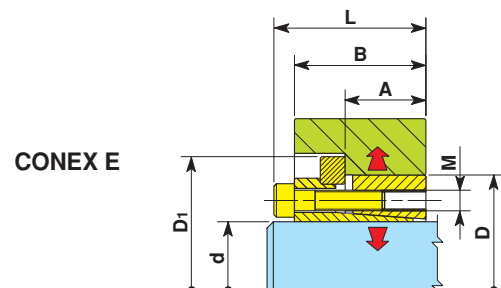
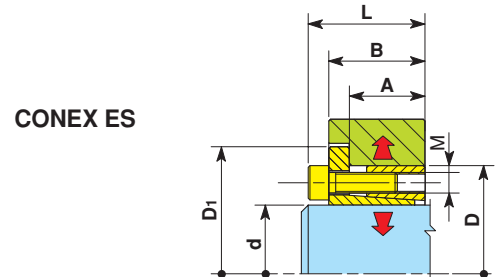

CONEX F CONEX G



AUTOCENTRANTE
COPPIE MOLTO ALTE
SELF CENTERING
VERY HIGH TORQUE
EFFET DE
CENTRAGE COUPLE
TRANSMISSIBLE
TRÈS ÉLEVÉ

CONEX H CONEX I



MONTAGGIO E
SMONTAGGIO
RAPIDI
QUICK MOUNTING
AND REMOVAL
MONTAGE ET
DÉMONTAGE
RAPIDE

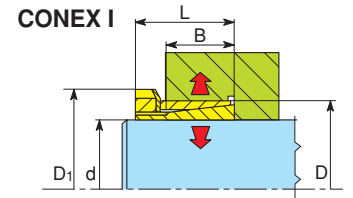
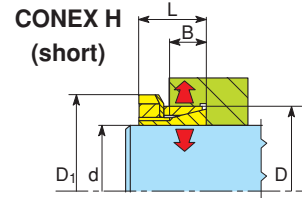
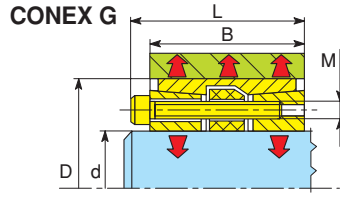
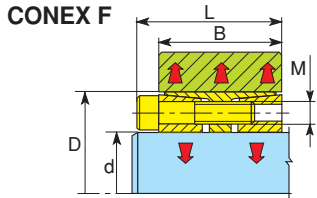

CONEX F - CONEX G			T _s Nm
d mm	D mm	M mm	
25	50	M 6	17
28	55	M 6	17
30	55	M 6	17
32	60	M 6	17
35	60	M 6	17
38	65	M 6	17
40	65	M 6	17
42	75	M 8	41
45	75	M 8	41
48	80	M 8	41
50	80	M 8	41
55	85	M 8	41
60	90	M 8	41
65	95	M 8	41
70	110	M 10	83
75	115	M 10	83
80	120	M 10	83
85	125	M 10	83
90	130	M 10	83
95	135	M 10	83
100	145	M 12	145
110	155	M 12	145
120	165	M 12	145
130	180	M 14	230
140	190	M 14	230
150	200	M 14	230
160	210	M 14	230
170	225	M 16	355
180	235	M 16	355
190	250	M 16	355
200	260	M 16	355
220	285	M 16	355
240	305	M 16	355
260	325	M 16	355
280	355	M 20	690
300	375	M 20	690
320	405	M 20	690
340	425	M 20	690
360	455	M 22	930
380	475	M 22	930
400	495	M 22	930

CONEX F		T Nm	F kN	p N/mm ²
B mm	L mm			
45	51	700	55	80
45	51	1000	70	90
45	51	1200	70	90
45	51	1300	70	90
45	51	1400	70	90
45	51	1850	90	100
45	51	2000	90	100
45	51	2900	140	130
45	51	3200	140	130
62	70	3400	140	80
62	70	3600	140	80
62	70	4000	140	80
62	70	5400	170	90
62	70	5800	170	90
76	86	10300	280	100
76	86	11000	280	100
76	86	14000	340	110
76	86	15000	340	110
76	86	16000	340	100
76	86	17000	340	100
98	110	26000	500	100
98	110	29000	500	100
98	110	36500	600	110
114	128	45400	700	100
114	128	57000	800	110
114	128	70000	900	120
114	128	75000	900	110
146	162	95000	1100	100
146	162	115000	1200	110
146	162	121500	1200	100
146	162	128000	1200	100
146	162	176000	1600	110
146	162	210000	1760	110
148	164	228000	1760	110
177	197	310000	2240	105
177	197	375000	2500	110
177	197	420000	2620	105
177	197	465000	2740	104
202	224	580000	3210	100
202	224	653000	3360	101
202	224	722000	3670	105

CONEX G		T Nm	F kN	p N/mm ²
B mm	L mm			
78	86	3600	180	65
78	86	5400	220	75
102	112	10300	350	75
102	112	14000	400	85
102	112	16000	430	75
122	134	26000	570	80

CONEX H - CONEX I		
d mm	D mm	D ₁ mm
14	25	32
15	25	32
16	25	32
17	25	32
18	30	38
19	30	38
20	30	38
22	35	45
24	35	45
25	35	45
28	40	52
30	40	52
32	45	58
35	45	58
40	50	65
45	55	70
50	60	75
55	65	80
60	70	85
70	84	98

CONEX H		T _N Nm	T Nm	F kN	p N/mm ²
B mm	L mm				
6,5	16,5	65	37	6	73
6,5	16,5	65	40	6	73
6,5	16,5	65	42	6	73
6,5	16,5	75	63	7	80
7	17	85	65	8	80
7	17	95	60	7	70
7	17	110	70	8	80
6,5	17	130	80	9	80
7	17	155	100	10	80
7	17	160	110	10	90
8	20	200	140	11	70
8	20	240	170	14	80
9	22	320	210	15	80
9	22	320	230	15	80
9	23	440	330	19	90
10	25,5	550	440	23	90
10	25,5	660	530	25	90
12	29,5	800	640	27	80
12	28,5	900	830	32	80
14	33	1200	1100	30	90

CONEX I		T _N Nm	T Nm	F kN	p N/mm ²
B mm	L mm				
17	29	90	90	15	80
17	29	90	100	15	80
17	29	70	80	12	60
18	31	90	113	12	70
18	31	190	200	25	110
18	31	150	170	20	90
18	31	110	130	15	60
22	35	130	180	18	60
22	35	230	270	26	80
22	35	170	200	20	60
22	35	390	460	40	110
22	35	240	300	24	70
28	42	320	420	31	70
28	42	320	460	31	60
28	44	440	640	37	70
28	45	550	760	40	60
28	46	660	930	44	60
28	46	800	1130	47	60
28	52	1050	1500	59	70
-	-	-	-	-	-

CONEX L

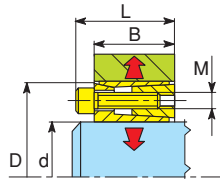

AUTOCENTRANTE COPPIE MEDIE
 SELF CENTERING MEDIUM
 TORQUES
 EFFET DE CENTRAGE COUPLES
 MOYENS

CONEX M

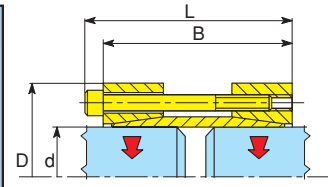

COLLEGA DUE ALBERI
 COASSIALI
 FOR CONNECTION OF
 COAXIAL SHAFTS
 POUR LIAISON DE ARBRES
 COAXIAUX

CONEX L					T _s Nm	T Nm	F kN	P N/mm ²
d mm	D mm	B mm	L mm	M mm				
16	32	17	22	M 4	5	80	13	68
18	40	18	24	M 6	17	180	24	100
19	41	18	24	M 6	17	190	24	100
20	42	18	24	M 6	17	200	24	100
22	44	18	24	M 6	17	220	24	90
24	46	18	24	M 6	17	360	36	130
25	47	18	24	M 6	17	380	36	130
28	50	18	24	M 6	17	420	36	120
30	52	18	24	M 6	17	450	36	120
32	54	18	24	M 6	17	480	36	110
35	57	22	28	M 6	17	700	36	90
38	60	22	28	M 6	17	750	36	85
40	62	22	28	M 6	17	800	36	80
42	70	28	36	M 8	41	1500	90	135
45	73	28	36	M 8	41	1700	90	130
50	78	28	36	M 8	41	1840	90	120
55	83	28	36	M 8	41	2000	90	130
60	88	28	36	M 8	41	2200	90	100
65	93	28	36	M 8	41	2400	110	110
70	105	35	45	M 10	80	4100	150	125
75	110	35	45	M 10	80	4400	150	120
80	115	35	45	M 10	80	4700	150	115
85	120	35	45	M 10	80	5500	180	125
90	125	35	45	M 10	80	5800	180	120
100	138	35	45	M 10	80	6500	180	110

CONEX M					T _s Nm	T Nm	F kN
d mm	D mm	B mm	L mm	M mm			
14	45	50	56	M 6	17	140	18
15	45	50	56	M 6	17	150	18
16	45	50	56	M 6	17	160	18
17	45	50	56	M 6	17	170	18
18	50	50	56	M 6	17	180	18
19	50	50	56	M 6	17	190	18
20	50	50	56	M 6	17	200	18
22	55	60	66	M 6	17	330	27
24	55	60	66	M 6	17	360	27
25	55	60	66	M 6	17	380	27
28	60	60	66	M 6	17	370	24
30	60	60	66	M 6	17	400	24
32	75	75	83	M 8	41	580	32
35	75	75	83	M 8	41	640	32
38	75	75	83	M 8	41	690	32
40	75	75	83	M 8	41	730	32
42	85	85	93	M 8	41	1100	48
45	85	85	93	M 8	41	1200	48
50	90	85	93	M 8	41	1340	48
55	95	85	93	M 8	41	1900	64
60	100	85	93	M 8	41	2200	64
65	105	85	93	M 8	41	2400	64
70	115	100	110	M 10	83	3200	80
75	120	100	110	M 10	83	3300	80
80	125	100	110	M 10	83	4800	110
90	135	100	110	M 10	83	5400	105
100	155	120	132	M 12	143	8700	150

CONEX K



AUTOCENTRANTE COPPIE
 MEDIE
 SELF CENTERING MEDIUM
 TORQUES
 EFFET DE CENTRAGE COUPLES
 MOYENS

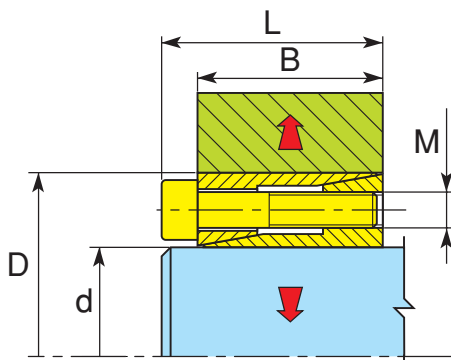

CONEX K					T _s Nm	T Nm	F kN	P N/mm ²
d mm	D mm	B mm	L mm	M mm				
5	16	11	13,5	2,5	1,2	5	2	55
6	16	11	13,5	2,5	1,2	6	2	55
6,35	16	11	13,5	2,5	1,2	6	2	55
7	17	11	13,5	2,5	1,2	8	2	55
8	18	11	13,5	2,5	1,2	10	2,5	50
9	20	13	15,5	2,5	1,2	15	3	55
9,53	20	13	15,5	2,5	1,2	15	3	55
10	20	13	15,5	2,5	1,2	15	3	55
11	22	13	15,5	2,5	1,2	18	3	50
12	22	13	15,5	2,5	1,2	20	3	50
14	26	17	20	3	2,1	35	5	55
15	28	17	20	3	2,1	40	5	50
16	32	17	21	4	4,9	70	8	65
17	35	21	25	4	4,9	75	8	60
18	35	21	25	4	4,9	80	8	60
19	35	21	25	4	4,9	85	8	60
20	38	21	26	5	9,7	150	15	75
22	40	21	26	5	9,7	160	14	70
24	47	26	32	6	16,5	250	20	75
25	47	26	32	6	16,5	260	20	75
28	50	26	32	6	16,5	440	30	100
30	55	26	32	6	16,5	470	30	95
32	55	26	32	6	16,5	500	30	95
35	60	31	37	6	16,5	730	40	95
38	65	31	37	6	16,5	800	40	90
40	65	31	37	6	16,5	840	40	90
45	75	36	44	8	40	1300	55	90
50	80	36	44	8	40	1900	75	115



MIDAS

Modular System



DIAMETRI ESTERNI UGUALI E INTERNI VARIABILI. DIMENSIONI RADIALI RIDOTTE
 THE SAME OUTER DIAMETER AND A RANGE OF INNER DIAMETERS.
 SMALL RADIAL DIMENSIONS
 MEME DIAMETRE EXTERIEURS ET UNE GAMME DES DIAMETRES INTERIEURS.
 DIMENSIONS RADIALES RÉDUITES

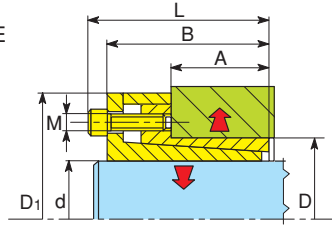

CONEX EP

Modular System

DIAMETRI ESTERNI UGUALI E INTERNI VARIABILI
 THE SAME OUTER DIAMETER AND A RANGE OF INNER DIAMETERS
 MEME DIAMETRE EXTERIEURS ET UNE GAMME DES DIAMETRES INTERIEURS

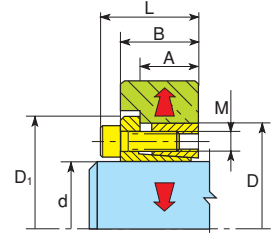

MIDAS								T _s Nm	T Nm	F kN	P N/mm ²
Mi-das	d mm	D mm	D ₁ mm	A mm	B mm	L mm	M mm				
2614	10-11-12	26	40,5	14	27,5	31,5	4	5	40-50-55	10	100
	14-15-16								90-95-115		
	18-19-20								130-140-145		
3814	19-20-22	38	57	14	33	39	6	17	195-200-240	22	104
	24-25-28-30								265-275-310-330		
3827	19-20-22	38	57	27	46	52	6	17	310-330-360	34	81
	24-25-28-30								400-410-460-500		
5227	24-25-28-30	52	70,5	27	46	52	6	17	470-490-550-590	44	79
	32-35-38-40-42								700-770-840-880-920		
7237	28-30-32-35	72	96,5	37	60	68	8	41	1240-1330-1420-1550	105	99
	38-40-42-45								1780-1880-1970-2110		
	48-50-55-60								2250-2350-2590-2820		

CONEX EP								T _s Nm	T Nm	F kN	P N/mm ²
EP	d mm	D mm	D ₁ mm	A mm	B mm	L mm	M mm				
55	14-16	55	62	23	31	39	8	41	287-329	41	103
	18-19-20								370-390-410		
65	22-24-25	55	62	23	31	39	8	41	451-492-513	41	103
	28-30								575-616		
80	24-25	65	72	23	31	39	8	41	616-641	51	111
	28-30-32								718-770-821		
80	35-38-40	65	72	23	31	39	8	41	898-975-1026	51	111
	30-32-35								1077-1150-1257		
	38-40								1364-1436		
	42-45-48-50								1509-1616-1723-1796		

CONEX DATI TECNICI

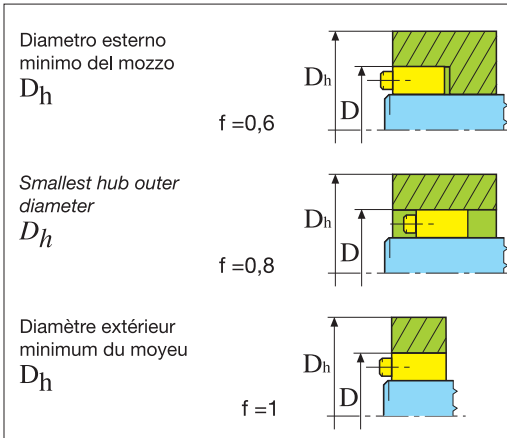

CONEX TECHNICAL DATA

p N/mm ²	f	C G25 σ = 180 N/mm ²	C St 37 σ = 220 N/mm ²	C C 40 σ = 300 N/mm ²
60	0,6	1,25	1,18	1,12
	0,8	1,30	1,23	1,18
	1	1,42	1,32	1,22
80	0,6	1,31	1,25	1,18
	0,8	1,45	1,35	1,24
	1	1,61	1,46	1,31
100	0,6	1,41	1,32	1,22
	0,8	1,61	1,46	1,31
	1	1,86	1,63	1,41
130	0,6	1,59	1,45	1,30
	0,8	1,93	1,67	1,44
	1	2,49	1,97	1,59
160	0,6	1,81	1,60	1,39
	0,8	2,43	1,94	1,58
	1	4,12	2,52	1,81

SPECIFICATIONS TECHNIQUES

- p** PRESSIONE SUL MOZZO
 HUB SURFACE PRESSURE
 PRESSION SUR LE MOYEU
- f** COEFFICIENTE DI FORMA
 FORM FACTOR
 FACTEUR DE FORME
- σ** LIMITE SNERVAMENTO DEL MOZZO
 HUB MATERIAL YIELD POINT
 LIMITE D'ÉLASTICITÉ DU MOYEU
- C** $D_{h \min} = C \cdot D$

Tolleranze albero ①,
 sede mozzo ②
 e rugosità superfici ③

Shaft ① and hub
 bore ② fit tolerances
 and surfaces roughness ③

Tolerances de l'arbre ①
 et de l'alésage ②
 et état de surfaces ③

CONEX	①	②	③
A	k11 - h11	N11 - H11	R _t ≤ 16 μm
SD - d _s < 30	j6	H6	R _t ≤ 16 μm
	h6	H6	R _t ≤ 16 μm
	g6	H6	R _t ≤ 16 μm
	g6	H7	R _t ≤ 16 μm
C - d < 38	h6	H7	R _t ≤ 6 μm
	h8	H8	R _t ≤ 6 μm
B - D - DS - E - ES - F - G - H - I - L - M - K - MIDAS - EP	h8	H8	R _t ≤ 16 μm

MONTAGGIO

Pulire e lubrificare tutte le superfici di contatto, inclusi i filetti, le teste delle viti, l'albero e il mozzo. Non usare olii contenenti additivi per alte pressioni (M₀ S₂).

Iniziare ad avvitare le viti e posizionare il mozzo. Serrare le viti con sequenza a croce in due o tre stadi fino a raggiungere la coppia di catalogo T_S. Ricontrollare la coppia di serraggio di tutte le viti.

Solo per CONEX A: le viti argentate devono essere avvitate nei fori con filetto di estrazione nell'anello conico anteriore.

Per tutti gli altri CONEX, i filetti di estrazione dell'anello conico anteriore, impiegati per lo smontaggio, devono essere in corrispondenza di spazi non forati sul cono posteriore, ed eventualmente impiegati per sbloccare CONEX prima del montaggio.

SMONTAGGIO

Sbloccare le viti di qualche giro.

CONEX A. Normalmente il semplice sbloccaggio delle viti ne provoca lo sbloccaggio a causa dell'ampio angolo dei coni: se necessario, battere leggermente sulle viti per sbloccare l'anello conico posteriore (fig. 1). Se l'anello conico anteriore è bloccato, rimuovere le viti argentate sotto le quali si trovano i filetti di estrazione; su di essi avvitare le viti di estrazione e tirare (fig. 2). I filetti di estrazione hanno solo 3 filetti; per le viti di estrazione usare una grandezza superiore alle viti di montaggio.

CONEX B, D, DS, E, ES, L, K, MIDAS, EP.

Rimuovere le viti e avvitare nei fori filettati di estrazione nell'anello conico anteriore, spingere sull'anello conico posteriore e sbloccare CONEX (fig. 3, 4). Togliere le viti dai fori di estrazione solo dopo che CONEX è stato estratto dal mozzo.

CONEX F, G

– Smontaggio 1 (fig. 5): rimuovere le viti e avvitare nei fori filettati di estrazione nell'anello conico anteriore, sbloccando.

– Smontaggio 2 (fig. 6): avvitare le viti nei fori filettati nella flangia centrale e sbloccare l'anello conico posteriore.

INSTALLATION

Clean and slightly oil all contact surfaces, including screw threads, screw heads, shaft and hub. Do not use oils containing Molybdenum Disulphide.

Tighten screws lightly and align hub. Tighten screws in diametrically opposite sequence in two or three stages up to the catalogue tightening torque T_S. Re-check tightening torque by applying it to all the screws.

For CONEX A: the silver plated screws are to be fitted in the holes of the front thrust ring with the pull-out threads.

For all the others CONEX, the release threads of the front ring, used for removal, have to be positioned opposite to undrilled spaces of the rear ring, and eventually used to release CONEX before the mounting.

REMOVAL

Loosen all screws by a few turns.

CONEX A. Normally it release itself because of the wide cone angle; if necessary lightly tap the screws to release the rear thrust ring (fig. 1). If the front thrust ring is locked, use screws of next size up, screwed in to the removal pull-out threads, located under the silver plated screws, and pull the front ring off (fig. 2). The removal threads have only 3 threads.

CONEX B, D, DS, E, ES, L, K, MIDAS, EP.

Remove the screws and screw them into the release threads of the front ring, pressing off the rear ring and releasing CONEX (fig. 3, 4). Remove the screws from the release threads only after CONEX has been taken out of the hub.

CONEX F, G

– Dismounting 1 (fig. 5): Remove the screws and screw them in the threaded bores in the front thrust ring and release it.

– Dismounting 2 (fig. 6): Screw the screws in the threaded bores in the central flange and release the rear thrust ring.

INSTRUCTION DE MONTAGE

Huiler légèrement toutes les surfaces en contact, aussi le filetage des vis, le dessous de la tête des vis, l'arbre et l'alésage du moyeu de l'organe à monter. Ne pas utiliser des huiles contenant le bisulfure de Molybdène.

Serrer légèrement les vis et introduire le CONEX dans le moyeu de l'organe à monter. Glisser cet ensemble sur l'arbre. Serrer uniformément et alternativement, en deux ou trois fois, les vis en position opposées jusqu'à l'obtention du couple de serrage T_S, indiqué dans le catalogue.

Pour le CONEX A: Les vis de couleur argentée doivent être montées dans les trous filetés dans l'anneau frontal spécialement prévu pour le démontage.

Pour les autres CONEX, les trous pour le démontage dans l'anneau frontal doivent être positionnés en face de la matière pleine de l'anneau postérieur.

INSTRUCTION DE DEMONTAGE

Devisser de quelques tours toutes les vis. CONEX A. Normalement il se désolidarise sans autres interventions grâce à l'angle ouvert du cône; si nécessaire l'anneau postérieur peut se débloquent en tapant légèrement sur les vis (fig. 1). Si l'anneau frontal reste bloqué on peut introduire des vis d'une taille supérieur dans les trous des vis argentées et retirer l'anneau frontal (fig. 2). Le filetage de ces trous a seulement 3 filets.

CONEX B, D, DS, E, ES, L, K, MIDAS, EP.

Enlever les vis et les placer dans les trous filetés pour le démontage. Par l'action de la vis contre l'anneau postérieur l'ensemble CONEX se désolidarise (fig. 3, 4). Retirer définitivement les vis qu'après le démontage complet du CONEX.

CONEX F, G

– Démontage 1 (fig. 5): retirer les vis et visser les dans les trous filetés de l'anneau frontal qui se désolidariserà.

– Démontage 2 (fig. 6): visser les vis dans l'anneau central et repousser l'anneau postérieur.

CONEX: SMONTAGGIO - REMOVAL - DÉMONTAGE

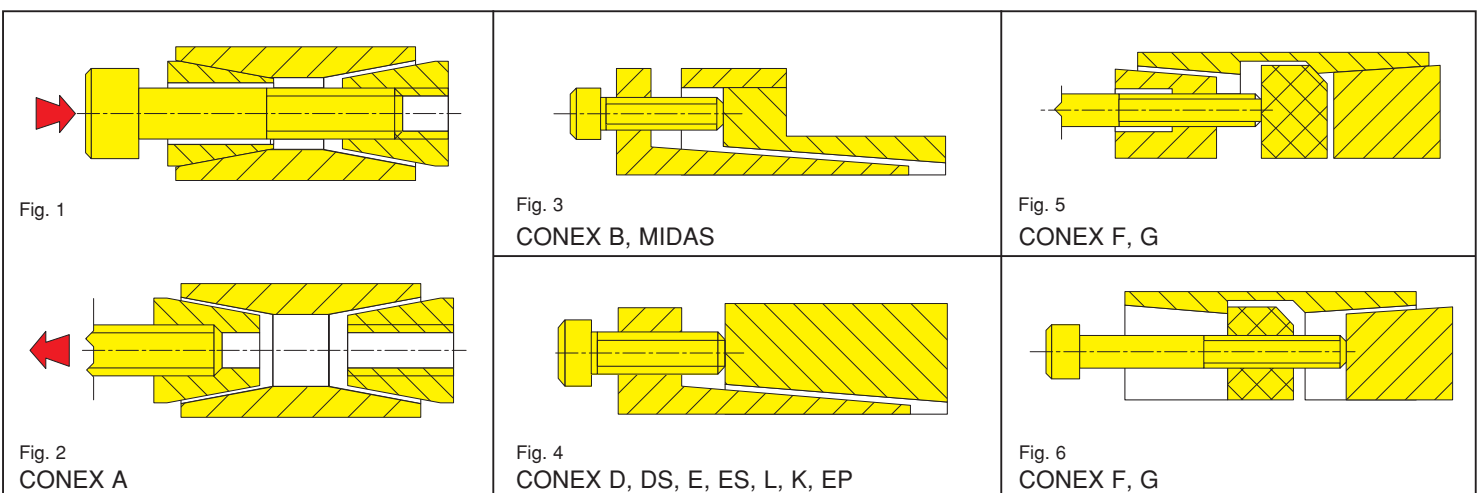

COEFFICIENTE DI SERVIZIO DUTY FACTOR FACTEUR DE SERVICE	MOTORE MOTOR MOTEUR	CARICO - LOAD - CHARGE		
		uniforme constant normal	leggeri sovraccarichi light overloads surcharges légères	forti sovraccarichi heavy overloads surcharges lourdes
I valori di catalogo T e F devono essere corretti con adeguato coefficiente di servizio, in funzione dell'applicazione. <i>The values T and F on the catalogue must be corrected with a duty factor depending from the type of work.</i>	elettrico electric électrique	1	1,5	2
Les valeurs T et F dans le catalogue doivent être corrigées avec un facteur de service en fonction des différentes applications.	a scoppio combustion à combustion	1,5	2	2,5