

LINEAR ROLLER BEARINGS

T RACE's range of linear bearings are setting new standards due to its innovative design and technical concepts.

The family MONORACE, based on a different C-shaped rails with wide range of sliders, is offering unique linear solutions for all kinds of automation applications for many industries.

T RACE's system with roller sliders and internal raceways, offer the markets highest performing system along with being size wise the most compact system.

The rails series MR – ML are high precision cold-drawn profiles, made from a specific Casehardening steel alloy, to assure optimal surface hardening by nitrogen diffusion. In addition the treatment too provides a strong resistant against corrosion, meanwhile reducing the friction and wear, to assure a long life of the rail.

The rails of series LA, are rolled steel profiles for simple applications. INOX version too available for severe conditions.

The unique design of T RACE's linear bearings, along with the products capability to fit non precise installation constructions, assure an optimal linear solution for the wide range applications outside the typical machine tool market as : handling equipment, transport/military vehicles, office furniture, etc.

MONORACE LINEAR RAIL RANGE

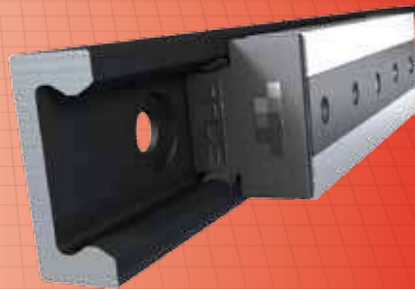
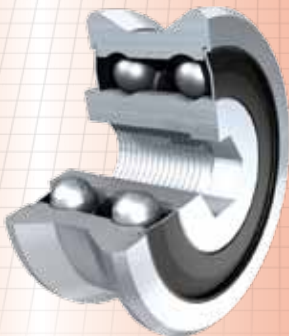

LINEAR ROLLER-SLIDES
SELFALIGNMENT WITH HIGH
PERFORMANCE.
DOUBLE ROW BALL-BEARINGS

Rails series MR

Slider series
RV, RA, RP, RF
RVT,RAT,RPT,RFT
RVS, RAS, RPS, RFS
RVSX, RASX, RPSX

page 4



LINEAR ROLLER-SLIDES
STANDARD SYSTEM WITH
SINGLE ROW BALL-BEARINGS

Rails series ML

Slider series
RL
RLS

page 10

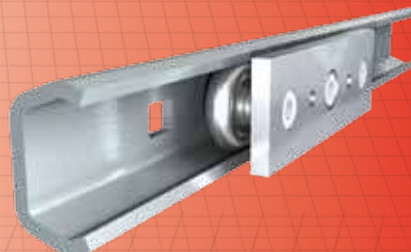
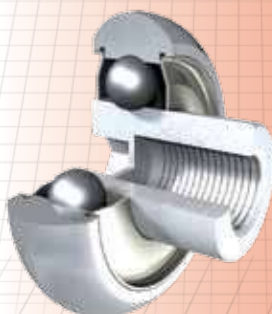

LINEAR ROLLER-SLIDES
ROLLED STEEL RAILS WITH
ROLLER-SLIDERS

Rails series LAZ, LAX

Slider series
PAZ
PAX

page 14

LINEAR ROLLER BEARING SYSTEM with MR rail and R, R.T, R.S sliders

The MR Series Linear Rail System consists of a C-section steel rail with internal convex raceways where robust double row ball bearing rollers travel. The high precision rollers are lubricated for life and protected with 2RS seals. Sliders are available with three or five rollers including eccentrics to adjust the bearing preload. Both ends of the sliders are equipped with polyimide wipers to remove debris from the raceway and grease impregnated felt wipers to lubricate the raceways for long life with minimal maintenance.

The MR rail system is especially equipped for harsh environments where contamination is a problem. Most bearing systems utilize a groove that a roller or ball travel within. These grooves capture and hold debris that eventually cause the bearing to fail. The convex raceway of the MR Series provides a place for debris and other contaminants to be pushed aside by the rollers. This feature enables the MR Series to function in environments where other bearings quickly fail.



Sliders Series: RV, RP, RA
R Sliders Series are made of Zinc plated steel with mounting holes parallel to the roller axes and perpendicular to the direction of preferred loading. The sliders have sealed rollers, axial wipers, and longitudinal seals for optimal protection of the internal parts and a sealing strip to prevent accidental tampering of the fixed rollers. The R Series Sliders are available in 3 sizes and with either 3 or 5 rollers.

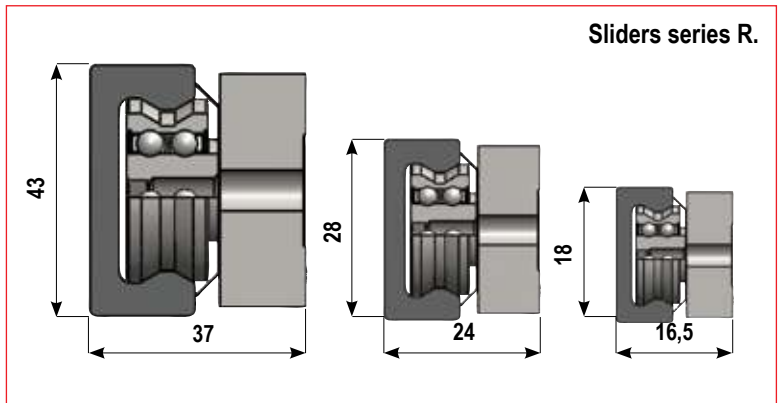

Sliders Series: RVT, RAT, RPT, RFT
R_T Sliders Series are made of Zinc plated steel with mounting holes perpendicular to the roller axes and parallel with the direction of preferred loading. The sliders have sealed rollers and axial wipers for protection of the internal parts. The R_T Series Sliders are available in 2 sizes and with either 3 or 5 rollers.

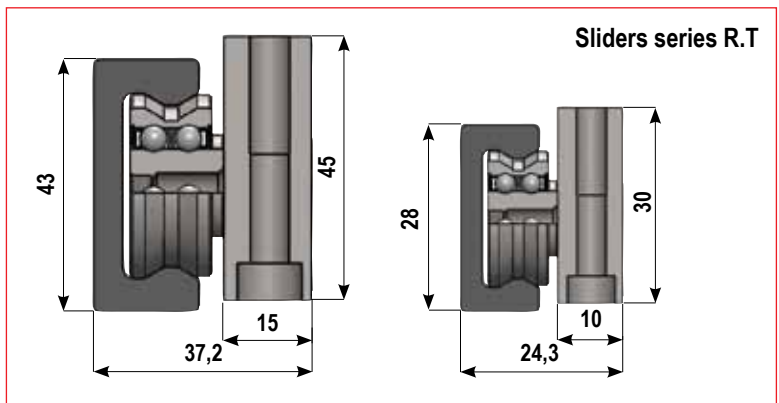

Sliders Series: RVS, RAS, RPS, RFS
The R_S Sliders Series have a very slim body to obtain the most compact slider possible, without sacrificing performance. They also offer both threaded and through hole mounting options. The standard slider body is made from Zinc plated steel but is also available in all Stainless Steel construction for higher corrosion resistance. The R_S Series Sliders are available in 2 sizes, 2 materials, and with either 3, 4 or 5 rollers.

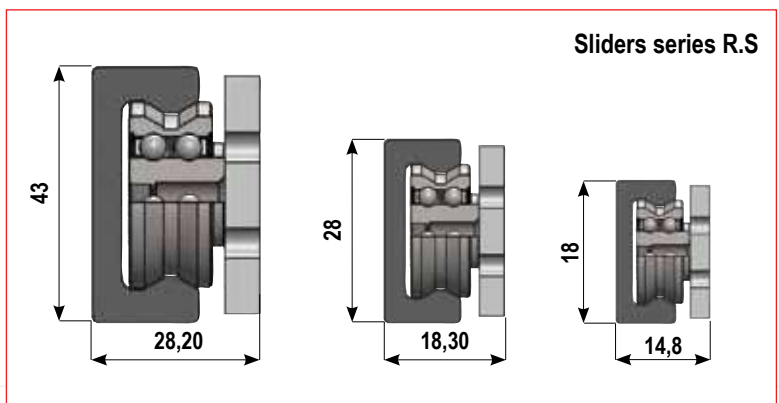

Sliders are available with either 3 or 5 rollers. For the 3 roller version, the first and third roller are fixed, concentric rollers that run on the same raceway. The second roller is eccentric and runs on the opposite raceway.

The eccentric feature is used to adjust the slider preload in the rail. For the 5 roller version, the two lateral and the central roller are fixed, concentric rollers that run on the same raceway.

The second and fourth roller are eccentric and run on the opposite raceway. The eccentric feature is used to adjust the slider preload in the rail. Because one raceway contacts more rollers than the other raceway, the sliders have a preferred loading direction.

The slider is marked with two small circular notches indicating the direction with the most rollers and direction of preferred loading. Care during assembly is required to ensure the maximum load capacity of the system is achieved.

The rollers used in the sliders consist of two different geometries to achieve different levels of constraint within the linear rails. Guiding Rollers (RCV, REV) contact the raceway at two points creating a well constrained rollers on the raceway. Floating Rollers (RCP, REP) engage only the peak of the raceway which constrains it radially but allows it to float in the axial direction between the two shoulders.

By using different combinations of guiding and floating rollers, sliders with different performance characteristics are obtained. These combinations can be used to avoid the binding that can occur because of alignment problems when mounting two linear bearings in parallel.

Guiding Sliders: By utilizing all guiding rollers RV, RTV, and RSV sliders are obtained, they are fully constrained and will support loads and moments in all directions with the greatest capacity in the radial direction.

Floating Sliders: By utilizing all floating rollers to construct RP, RSP, and RTP sliders are obtained, these sliders are able to carry full load in the radial direction and also float and rotate a small amount in the rail without affecting the preload or quality of the movement and without binding. Floating sliders are used in 2 rail systems to absorb parallelism errors in the mounting surfaces. For size 43 sliders, RF, RFT, and RFS sliders are available which allow even greater axial displacement.

Rotating Sliders: By mixing guiding and floating rollers to construct RA, RSA, and RTA sliders are obtained, these sliders are able to carry full load in the radial direction and also rotate slightly without affecting the preload or quality of movement. These sliders also retain the ability to guide the payload as it travels. Rotating sliders are used in 2 rail systems to absorb angular errors in the mounting surfaces, that cause traditional bearings to bind.

Combination: By combining a floating and rotating slider together in a 2 rail system, the MR rail system can carry and guide a full payload while compensating for parallelism and angular errors in the rail mounting surfaces. These types of errors are often found when mounting to welded frames, structural Aluminum frames, sheet metal structures, etc. The self alignment capability can eliminate the need to machine the rail mounting surfaces.

Selfaligning combination

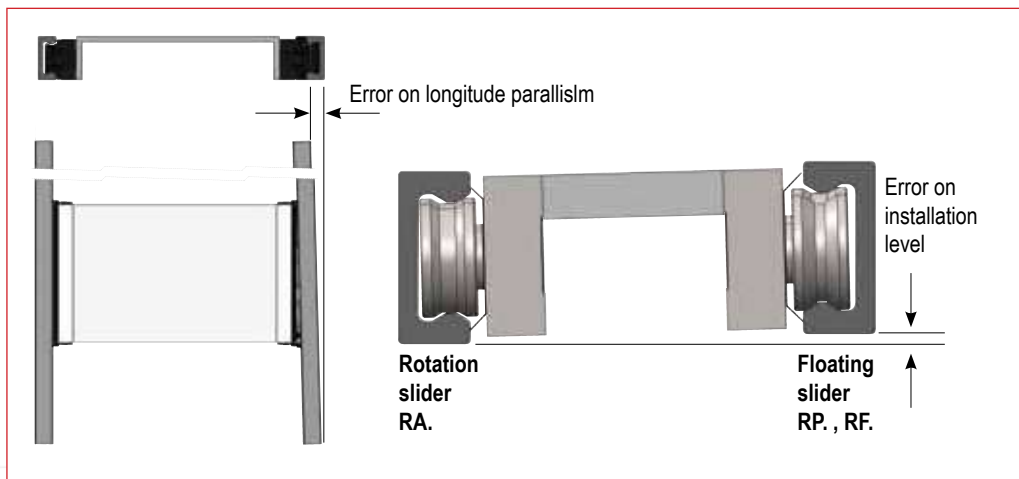

Roller loading position

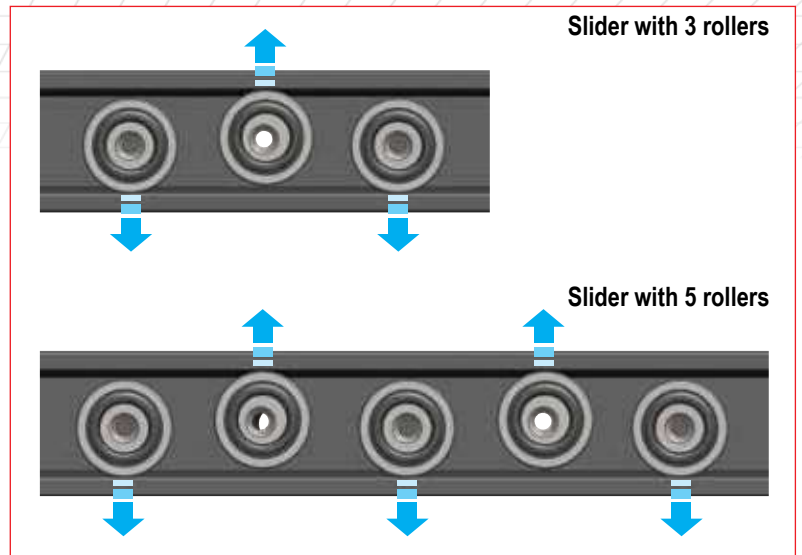

Roller contact points

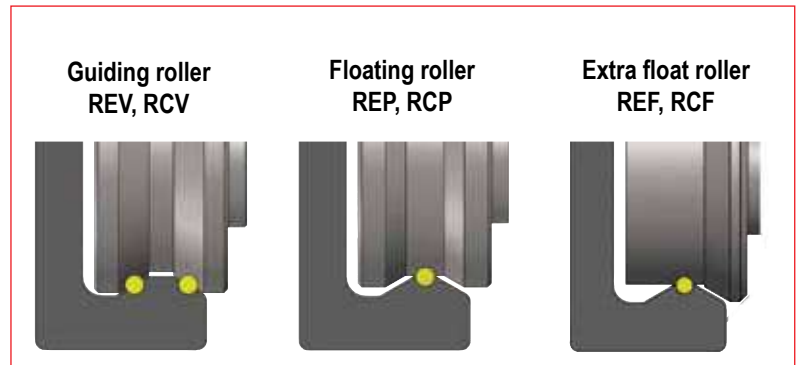

Slider contact points

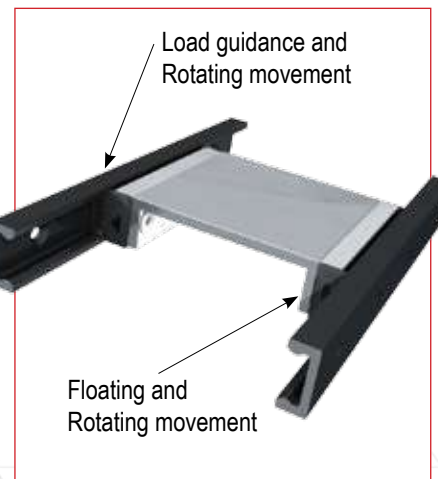
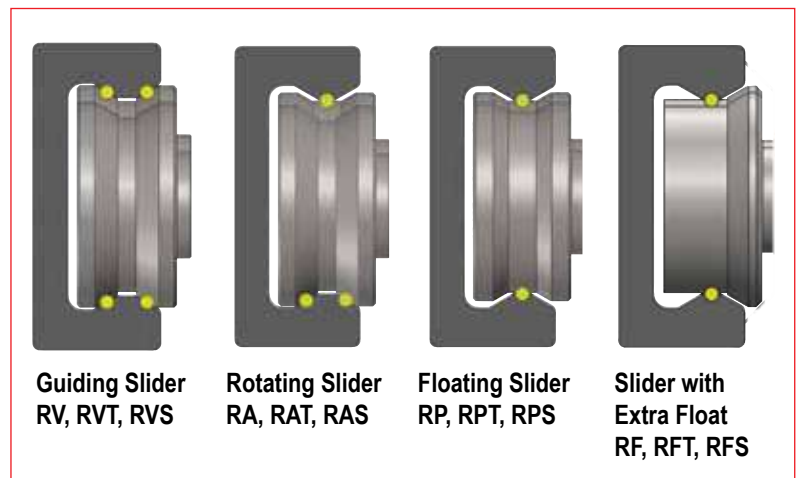

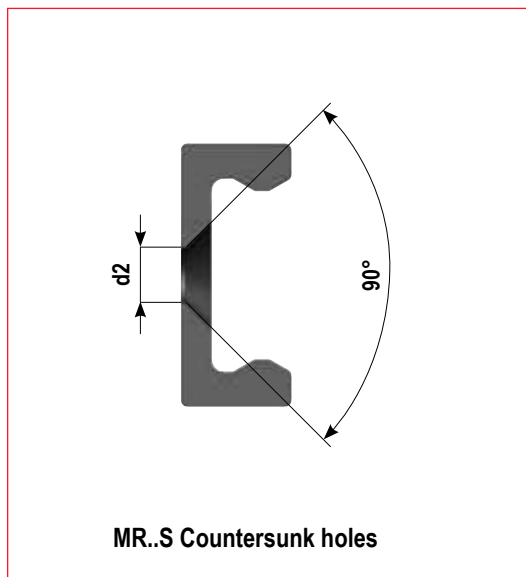
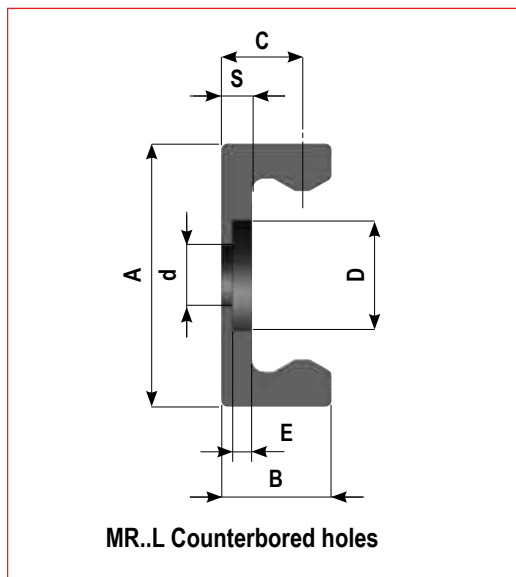
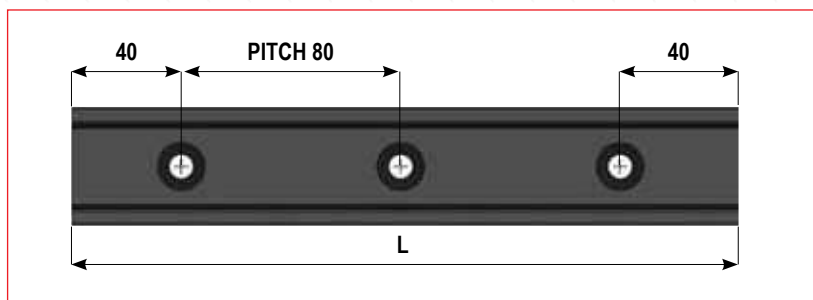

Lenght L (mm)		
MRG18	MR28	MR43
160		
240	240	
320	320	
400	400	400
480	480	480
560	560	560
640	640	640
720	720	720
800	800	800
880	880	880
960	960	960
1040	1040	1040
1120	1120	1120
1200	1200	1200
1280	1280	1280
1360	1360	1360
1440	1440	1440
1520	1520	1520
1600	1600	1600
1680	1680	1680
1760	1760	1760
1840	1840	1840
1920	1920	1920
2000	2000	2000
2080	2080	2080
2160	2160	2160
2240	2240	2240
2320	2320	2320
2400	2400	2400
2480	2480	2480
2560	2560	2560
2640	2640	2640
2720	2720	2720
2800	2800	2800
2880	2880	2880
2960	2960	2960
	3040	3040
	3120	3120
	3200	3200
	3280	3280
	3360	3360
	3440	3440
	3520	3520
	3600	3600
	3680	3680
	3760	3760
	3840	3840
	3920	3920
	4000	4000

(Code example: MR28L - 640)

Code	A (mm)	B (mm)	C (mm)	S (mm)	D (mm)	d (mm)	E (mm)	d2 (mm)	Screw type	Weight (Kg/m)
MRG18S	18	9,5	7,1	2,8				4,5	M4 DIN7991	0,68
MRG18L					9	5	1,9	M4 TORX *		
MR28S	28	12	8	3				5,5	M5 DIN7991	1,25
MR28L					11	6	2	M5 TORX *		
MR43S	43	18	13,2	5				8,5	M8 DIN7991	3,04
MR43L					18	10	3,2	M8 TORX *		

* Special flat-head TORX screws supplied with rails.

Screw type		G (mm)	S (mm)	V (mm)		Tightening Torque
M4 TORX	M4	8	1,9	8	T20	3,5 Nm
M5 TORX	M5	10	2	10	T25	10Nm
M8 TORX	M8	16	3	16	T40	20Nm

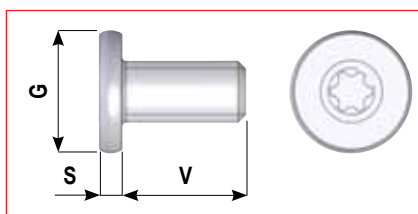

TECHNICAL

MR Series Rails are made in 3 sizes 18mm, 28mm and 43mm with two types of mounting holes: MR .. L with counterbored mounting holes for special low head TORX mounting screws that are provided with the rail. MR .. S with countersunk mounting holes for UNI-standard ISO5933 fasteners.

The rail has a "C" shaped cross-section with interior, convex raceways. The convex raceways are polished for smooth, low noise motion. The interior raceways are protected from accidental bumps and other damages, that can the surface.

The shape also protects the rollers from similar types of damages.

MR Series Rails are made from carbon steel that is hardened through high depth nitriding. The rails are then treated with the innovative TRACE-NOX process, which delivers excellent corrosion resistance.

This treatment is not a plating which can flake off but instead penetrates and alters the material surface. The result is a very hard and durable, corrosion resistance linear rail, that is black in color, due to the microimpregnation of oil and antioxidants.

R. sliders for MR rails

3 Rollers slider for R. series

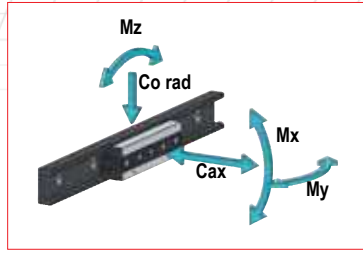
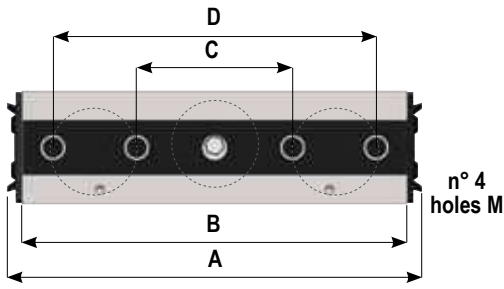

RV Guiding slider dimensions

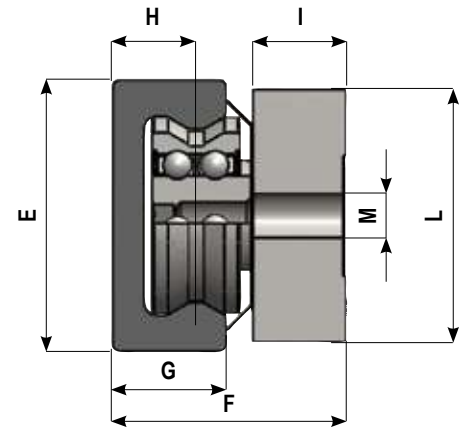

5 Rollers slider for R. series

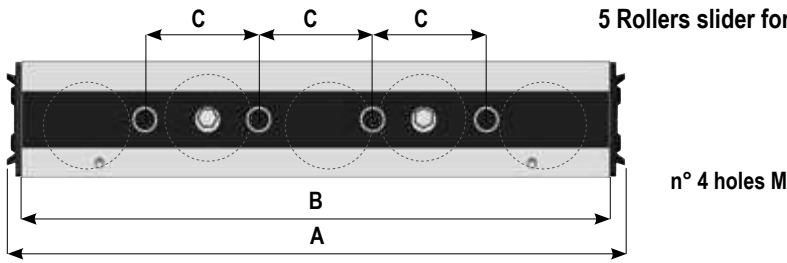

Code	Rail type	E (mm)	F (mm)	G (mm)	H (mm)	I (mm)	L (mm)	M (mm)	A (mm)	B (mm)	C (mm)	D (mm)	Weight (gr)	C (N)	Co rad (N)	Co ax (N)	Mx (Nm)	My (Nm)	Mz (Nm)
RVG18-3	MRG18	18	16,5	9,5	7,1	4,8	16	M5	77	70	20	52	75	3300	1600	690	3	9	15
RPG18-3														3300	1600	0	0	0	15
RAG18-3														3300	1600	460	3	9	15
RVG18-5									120	112	20	120	4455	2160	1150	6	18	48	
RPG18-5													4455	2160	0	0	0	48	
RAG18-5													4455	2160	690	6	18	48	
RV28-3	MR28	28	24	12	8	9,7	25	M5	102	94	35	78	240	6000	3200	1380	9	27	46
RP28-3														6000	3200	0	0	0	46
RA28-3														6000	3200	920	9	27	46
RV28-5									148	140	25	360	8100	4320	2300	18	46	120	
RP28-5													8100	4320	0	0	0	120	
RA28-5													8100	4320	1380	18	46	120	
RV43-3	MR43	43	37	18	13,2	14,8	40	M8	146	136	55	114	730	14200	7200	3210	32	92	155
RP43-3														14200	7200	0	0	0	155
RA43-3														14200	7200	2080	32	92	155
RF43-3									216	207	40	1130	19170	9720	5350	64	165	418	
RV43-5													19170	9720	0	0	0	418	
RP43-5													19170	9720	3560	64	165	418	
RA43-5									19170	9720	0	0	0	418					
RF43-5															19170	9720	0	0	0

RA series – Rotating slider

Series	(+/-) a°
RA18	1,5
RA28	1,5
RA43	1,5

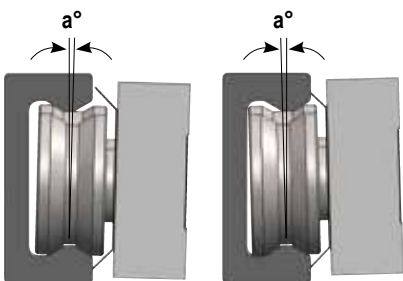

RP series – Floating slider

Series	a°	F Min	F Max
RP18	1,5	16	17
RP28	1,5	23,4	24,6
RP43	1,5	36	38

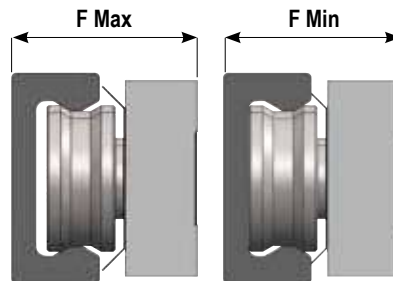

RF series – Extra floating slider

Series	a°	F Min	F Max
RF43	1,5	36	40

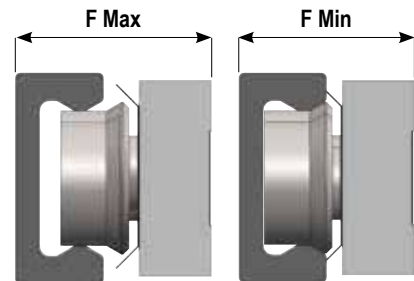

Sliders of series RVT, RAT, RPT, RFT, provide fixing holes parallel to the preferable radial load direction. As the slider body protrudes from rail level, moving part can be resting on top of the linear system, while being fixed from above with threaded holes or from below with through passing holes.

Slider type	Threaded holes for top mounting		Passing holes for bottom mounting, screw UNI 5931			
	d1 (mm)	N (mm)	Screw type	d2 (mm)	S (mm)	D (mm)
R.T28-3	M6	15	M5	Ø 5,5	5	Ø 9
R.T28-5	M6	15	M5	Ø 5,5	5	Ø 9
R.T43-3	M8	20	M6	Ø 6,5	6	Ø 10,5
R.T43-5	M8	20	M6	Ø 6,5	6	Ø 10,5

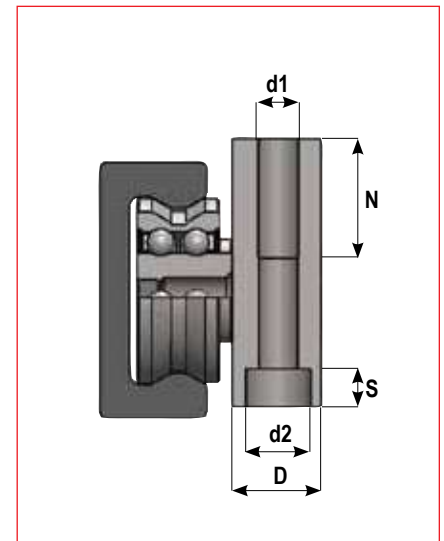

The A and B versions differ only in the arrangement of the rollers providing maximum radial load capacity either toward or against the mounting surface. The preferential loading direction is marked by two circular notches. (Ordering code example: RVT28-3A or RVT28-3B) The slider body allows two methods of mounting. One method is to pass a fastener through the counterbored hole into the payload or to pass a fastener through the payload into the tapped hole at M.

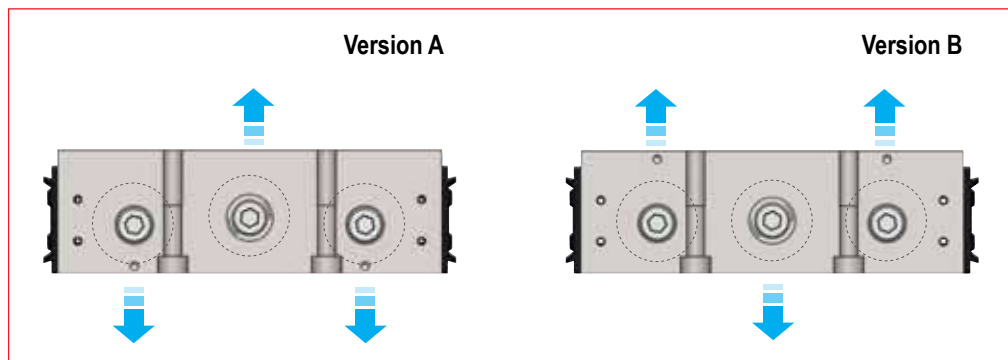
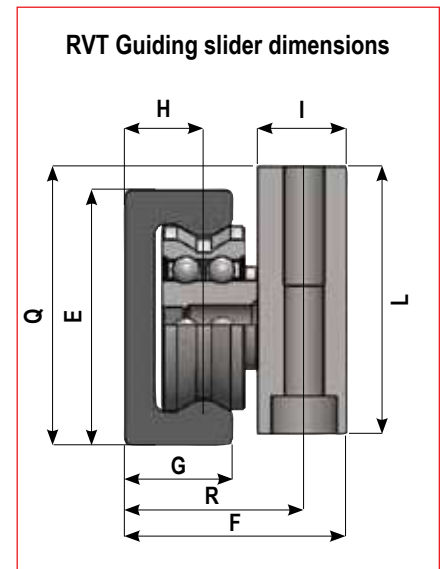

Rotation slider series RAT

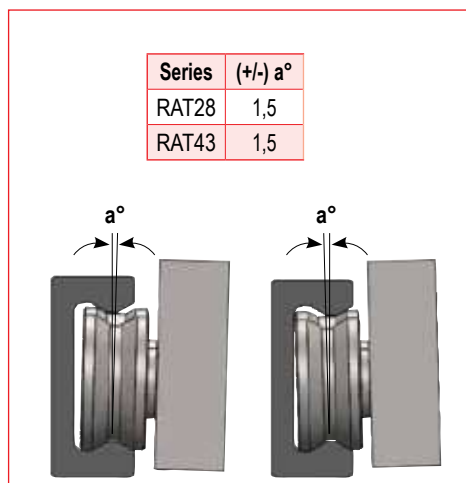

Floating slider series RPT

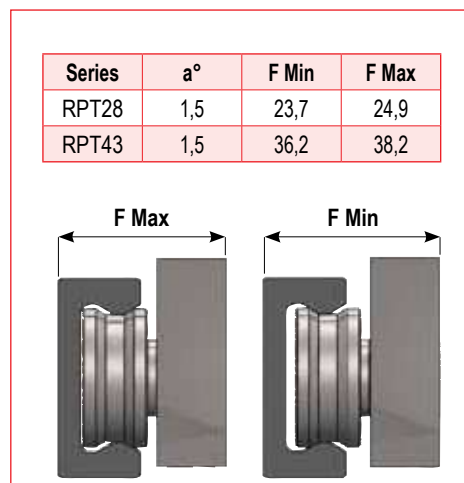

Extra floating slider series RFT

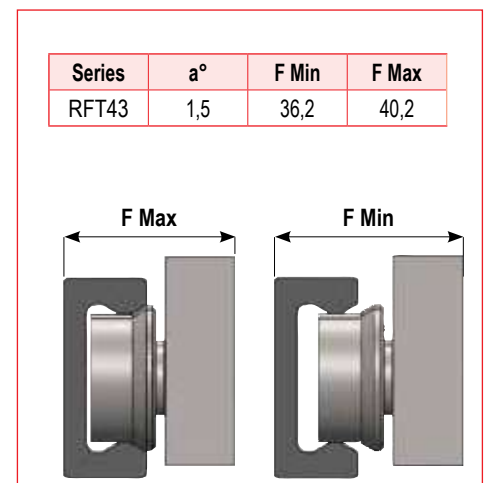

3 Rollers slider for R.T series – Version A

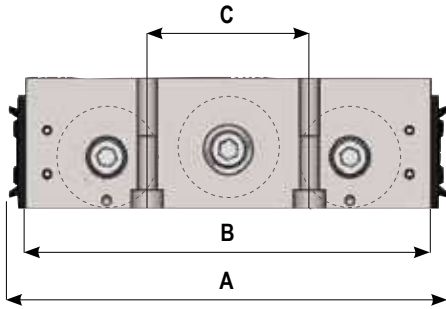

3 Rollers slider for R.T series – Version B

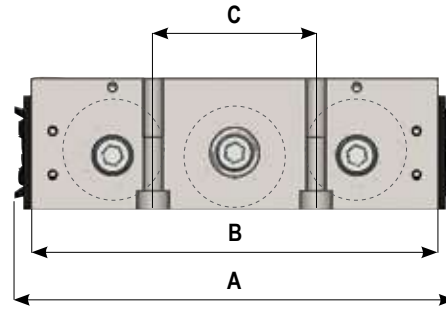

5 Rollers slider for R.T series – Version A

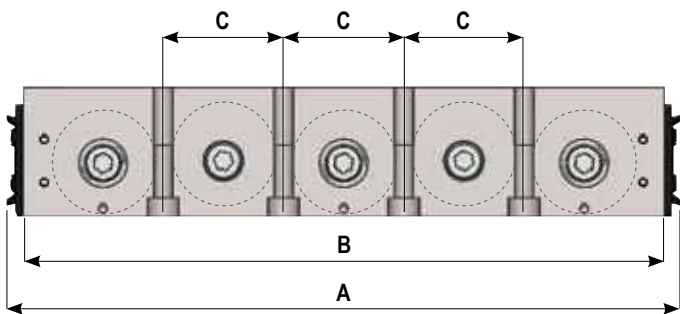

5 Rollers slider for R.T series – Version A

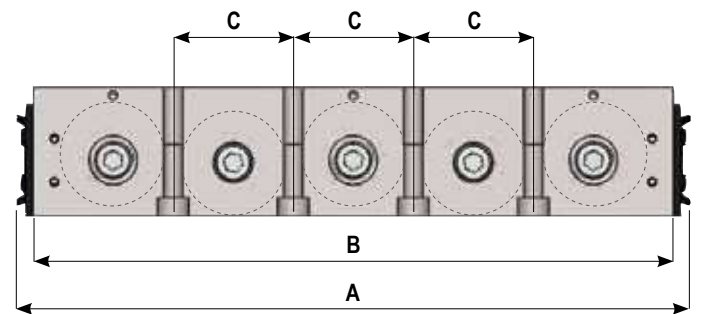

Code	Rail type	E (mm)	F (mm)	G (mm)	H (mm)	I (mm)	L (mm)	N (mm)	Q (mm)	R (mm)	A (mm)	B (mm)	C (mm)	Weight (gr)	C (N)	Co rad (N)	Co ax (N)	Mx (Nm)	My (Nm)	Mz (Nm)				
RVT28-3.	MR28	28	24,3	12	8	10	30	15	32	19,5	104	94	36	280	6000	3200	1380	9	27	46				
RPT28-3.															6000	3200	0	0	0	46				
RAT28-3.															6000	3200	920	9	27	46				
RVT28-5.															8100	4320	2300	18	46	120				
RPT28-5.															8100	4320	0	0	0	120				
RAT28-5.															8100	4320	1380	18	46	120				
RVT43-3.	MR43	43	37,2	18	13,2	15	45	20	47	30	151	140	56	730	14200	7200	3210	32	92	155				
RPT43-3.															14200	7200	0	0	0	155				
RAT43-3.															14200	7200	2140	32	92	155				
RFT43-3.															14200	7200	0	0	0	155				
RVT43-5.															235	224	42	1130	19170	9720	5350	64	165	418
RPT43-5.																			19170	9720	0	0	0	418
RAT43-5.																			19170	9720	3210	64	165	418
RFT43-5.																			19170	9720	0	0	0	418

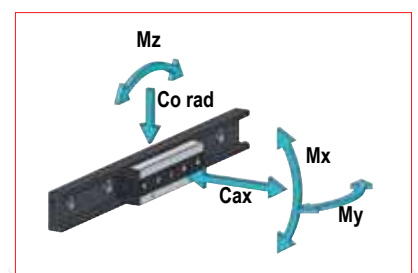

Example of order code.
RVT28-3B : Guiding slider with 3 roller, version B

Very compact slider, with slim strong slider body, for application with limited space. Performance like standard R-sliders for versions, except lateral fixing. Featuring extra long 4-roller version to optimize performance with only 1 slider, instead of 2 sliders.

Guiding slider series RVS.

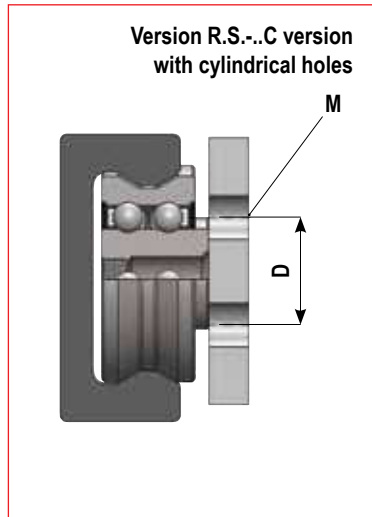
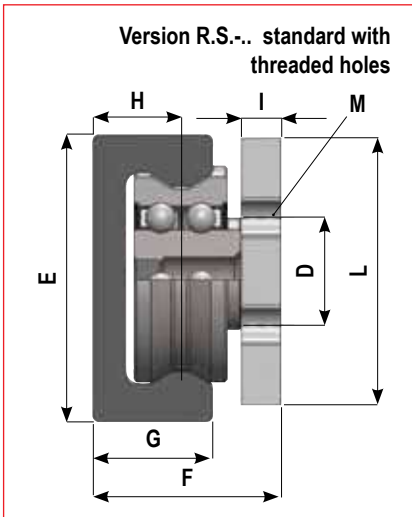

The sliders are available in standard version with threaded fixing holes R.S.-.. and in version ...C with through passing holes for inside fixing with standard cylindrical screws DIN912, with no interference with the rollers.

Slider type	M	Type of fixing screws
R.GS18-..	M4	
R.GS18-..C	Ø 4,5	M4 DIN912
R.S.28-..	M5	
R.S.28-..C	Ø 5,5	M5 DIN912
R.S.43-..	M6	
R.S.43-..C	Ø 6,5	M6 DIN912

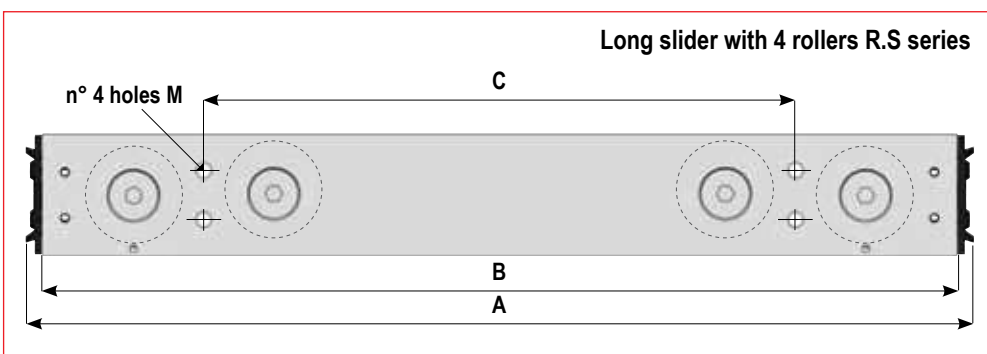
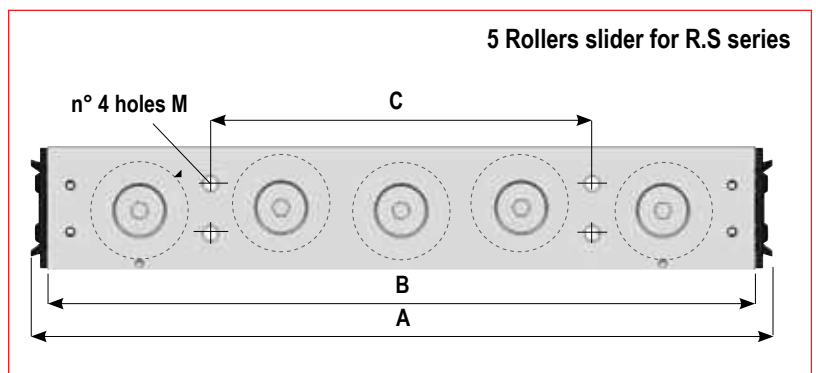
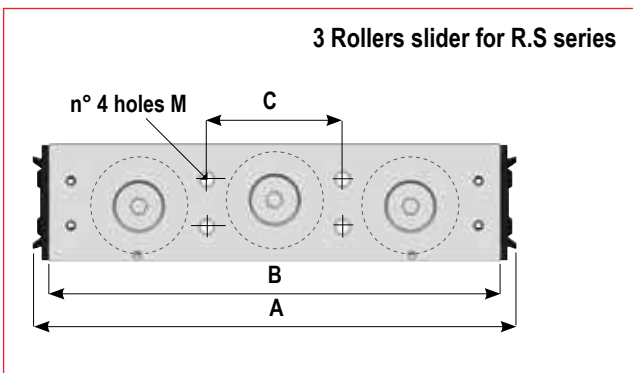

INOX Versions

The sliders in dimensions 28 and 43 are also available in INOX for version RVSX and RPSX. The rollers are hardened AISI 440, while slider body AISI 304.

The load capacities are identical to the standard version of RVS and RPS.

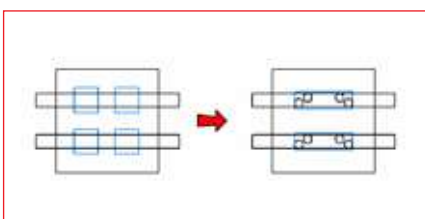

The extra long slider body for 4-roller sliders R.S.-4L are made to offer an economical alternative for the many cases where 2 sliders are used, merely for proportional reasoning, rather than for load capacities. Too very economical sliders for high M_z and M_y moment capacities.

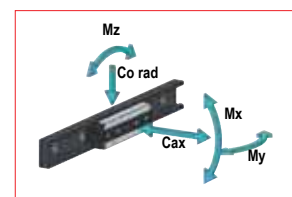

Example of order codes.

RVS28-3 : Guiding Slim-slider with 3 roller

RPS43-4LC : Extra long rotation Slim-slider with 4 rollers and cylindrical fixing holes

RVSX28-5: INOX guiding Slim-slider with 5 rollers

Rotating slider RAS series

Series	(+/-) a°
RAS18	1,5
RAS28	1,5
RAS43	1,5

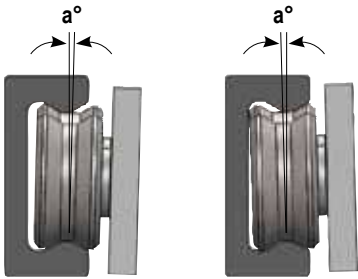

Floating slider RPS series

Series	a°	F Min	F Max
RPS18	1,5	14,3	15,3
RPS28	1,5	17,6	18,8
RPS43	1,5	27,2	28,2

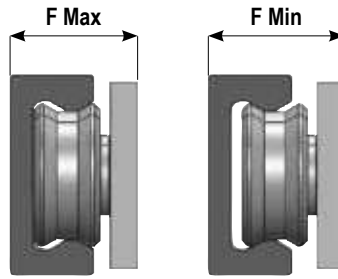

Extra floating slider RFS series

Series	a°	F Min	F Max
RFS43	1,5	27,2	30,2

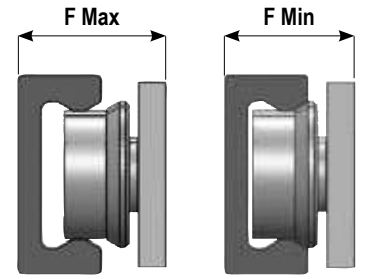

Code	Rail type	E (mm)	F (mm)	G (mm)	H (mm)	I (mm)	L (mm)	A (mm)	B (mm)	C (mm)	D (mm)	Weight (gr)	C (N)	Co rad (N)	Co ax (N)	Mx (Nm)	My (Nm)	Mz (Nm)
RVGS18-3	MRG18	18	14,8	9,5	7,1	3	15	82	73	21	8	75	3300	1600	690	3	9	16
RPGS18-3													3300	1600	0	0	0	16
RAGS18-3													3300	1600	460	3	9	16
RVGS18-5								110	102	50	8	120	4455	2160	1150	6	19	49
RPGS18-5													4455	2160	0	0	0	49
RAGS18-5													4455	2160	690	6	19	49
RVGS18-4L								160	150	98	8	125	3300	1600	920	6	27	78
RPGS18-4L													3300	1600	0	0	0	78
RAGS18-4L													3300	1600	460	6	27	78
RVS.28-3.	MR28	28	18,2	12	8	4	25	118	108	32,5	10	140	6000	3200	1380	9	30	52
RPS.28-3.													6000	3200	0	0	0	52
RAS.28-3.													6000	3200	920	9	30	52
RVS.28-5.								166	156	82	10	210	8100	4320	2300	18	52	130
RPS.28-5.													8100	4320	0	0	0	130
RAS.28-5.													8100	4320	1380	18	52	130
RVS.28-4L.								210	200	126	10	230	6000	3200	1840	18	73	202
RPS.28-4L.													6000	3200	0	0	0	202
RAS.28-4L.													6000	3200	920	18	73	202
RVS.43-3.	MR43	43	28,2	18	13,2	6	40	164	153	46	16	440	14200	7200	3210	32	98	165
RPS.43-3.													14200	7200	0	0	0	165
RAS.43-3.													14200	7200	1240	32	98	165
RFS.43-3.								14200	7200	0	0	0	165					
RVS.43-5.								239	230	124	16	670	19170	9720	5350	64	180	440
RPS.43-5.													19170	9720	0	0	0	440
RAS.43-5.													19170	9720	3210	64	180	440
RFS.43-5.								19170	9720	0	0	0	440					
RVS.43-4L.								311	300	194	16	750	14200	7200	4280	64	257	698
RPS.43-4L.	14200	7200	0	0	0	698												
RAS.43-4L.	14200	7200	2140	64	257	698												
RFS.43-4L.	14200	7200	0	0	0	698												

LINEAR ROLLER BEARING SYSTEM

with ML rail and RL, RLS sliders

The ML Series Linear Rail System consists of a C shaped steel rail with internal concave raceways where robust ball bearing rollers travel. The high precision rollers are lubricated for life and protected with 2Z seals. Sliders are available with three or five rollers including eccentrics to adjust the slider's preload. Both ends of the sliders are equipped with polyimide wipers to remove debris from the raceway and grease impregnated felt wipers to lubricate the raceways for long life with minimal maintenance.

Sliders include a mix of concentric and eccentric rollers. The eccentric rollers are used to preload the system and eliminate any play. The preload can be adjusted to suit the particular application. Sliders are able to carry load and moment loads in all direction. Because one of the rail raceways contacts more rollers than the other, this direction is the preferred direction of radial loading. Two small circular marks indicate the direction of preferred slider loading.

The ML Systems's C shaped steel rail has internal raceways that are protected from accidental damage. Similarly, the rollers are protected inside the rail and under the slider body.

Overall, the ML Series Linear Rail Systems is easy to assembly and extremely compact..



RLV Series Sliders RLV Series Sliders are made of strong Zinc plated steel body, with mounting holes parallel to the roller axles and perpendicular to the direction of preferred loading. The sliders have wipers with incorporate preoiled felt for lubrication of raceways. The RLV Series Sliders are available in 2 sizes and with either 3 or 5 rollers.

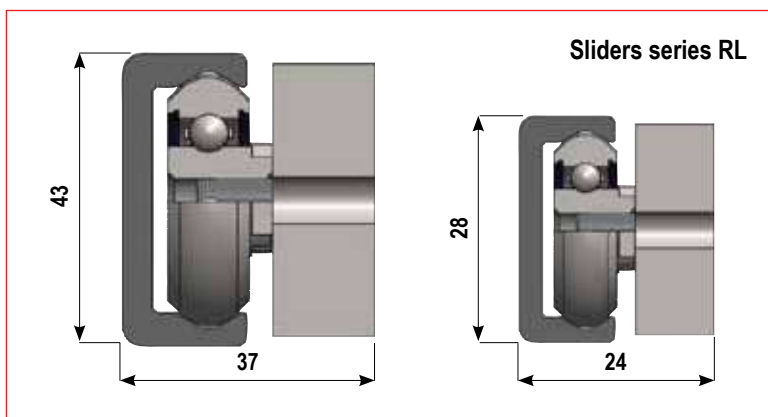

RLS Series Sliders The RLS Series Sliders have a very slim body, as the most compact slider, without sacrificing performance. They also offer both threaded and through hole mounting options (RLS and RLSC). The standard slider body is made from Zinc plated steel but is also available in complete inox. The RLS Series Sliders are available in 2 sizes, 2 materials, and with either 3, 4 or 5 rollers.

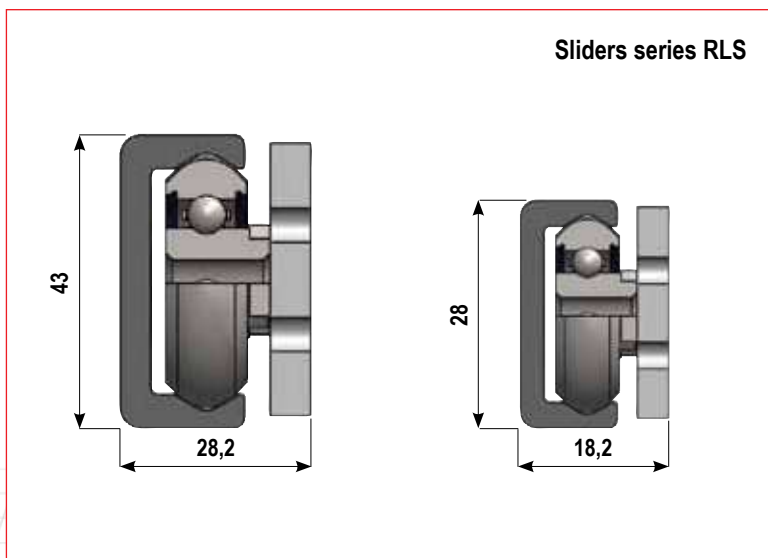

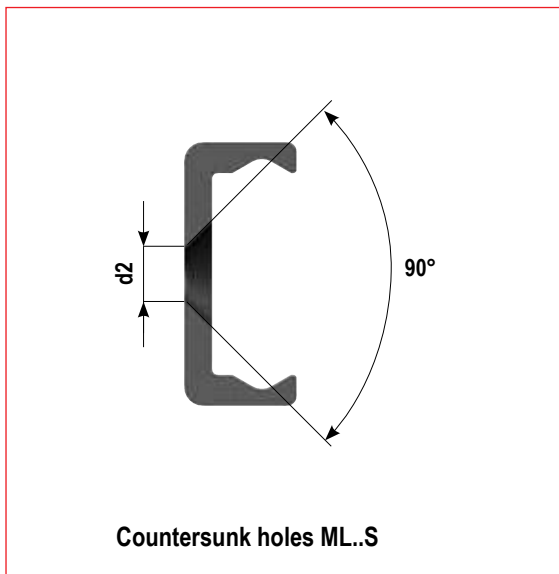
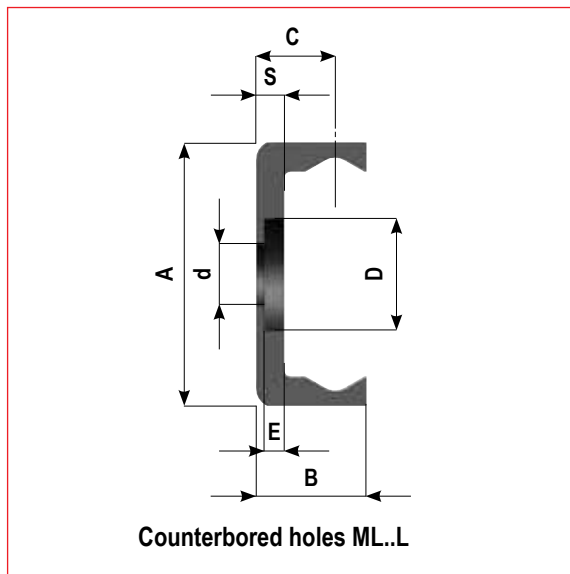
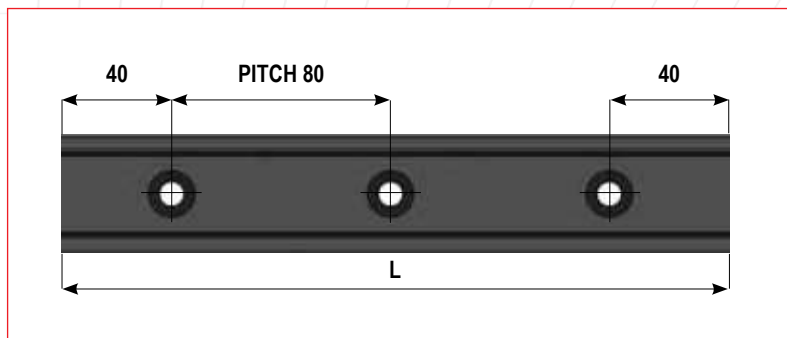

Lenght L (mm)	
ML28	ML43
240	
320	
400	400
480	480
560	560
640	640
720	720
800	800
880	880
960	960
1040	1040
1120	1120
1200	1200
1280	1280
1360	1360
1440	1440
1520	1520
1600	1600
1680	1680
1760	1760
1840	1840
1920	1920
2000	2000
2080	2080
2160	2160
2240	2240
2320	2320
2400	2400
2480	2480
2560	2560
2640	2640
2720	2720
2800	2800
2880	2880
2960	2960
3040	3040
3120	3120
3200	3200
3280	3280
3360	3360
3440	3440
3520	3520
3600	3600
3680	3680
3760	3760
3840	3840
3920	3920
4000	4000

(Code example: ML28L - 640)

Code	A (mm)	B (mm)	C (mm)	S (mm)	D (mm)	d (mm)	E (mm)	d2 (mm)	Screw type	Weight (kg/m)
ML28S	28	11	8,2	3				5,5	M5 DIN7991	1
ML28L					11	6	2	M5 TORX*		
ML43S	43	18,3	12,65	4,5				8,5	M8 DIN7991	2,3
ML43L					18	10	3,2	M8 TORX*		

* Special flat-head TORX screws supplied with rails.

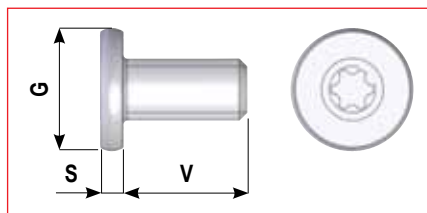

Screw type		G (mm)	S (mm)	V (mm)		Tightening Torque
M5 TORX	M5	10	2	10	T25	10Nm
M8 TORX	M6	16	3	16	T40	20Nm

TECHNICAL DATA

ML Series Rails are made in two sizes 28mm and 43mm with two types of mounting holes: ML .. L with counterbored mounting holes for special low head TORX mounting screws that are provided with the rail. ML .. S with countersunk mounting holes for UNI-standard ISO5933 fasteners. The rail has a "C" shaped cross-section with interior, concave raceways.

The concave raceways are polished for smooth, low noise motion. The interior raceways are protected from accidental bumps and other damage that can spoil the surface. The shape also protects

the rollers from similar types of damage.

ML Series Rails are made from carbon steel, that is hardened through high depth nitriding.

The rails are then treated with the innovative TRACE-NOX process which delivers excellent corrosion resistance. This treatment is not a plating which can flake off, but instead penetrates and alters the material surface.

The result is a very hard and durable, corrosion resistance linear rail that is black in color, due to the microimpregnation of oil and antioxidants.

The sliders of series RL offer a strong body with 4 fixing holes.

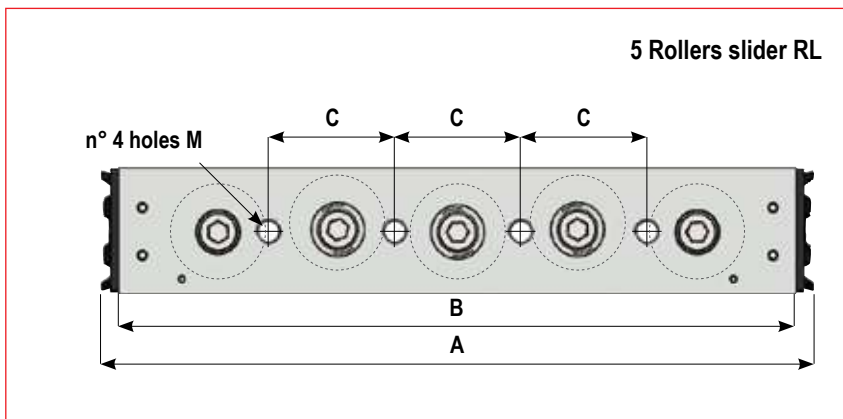
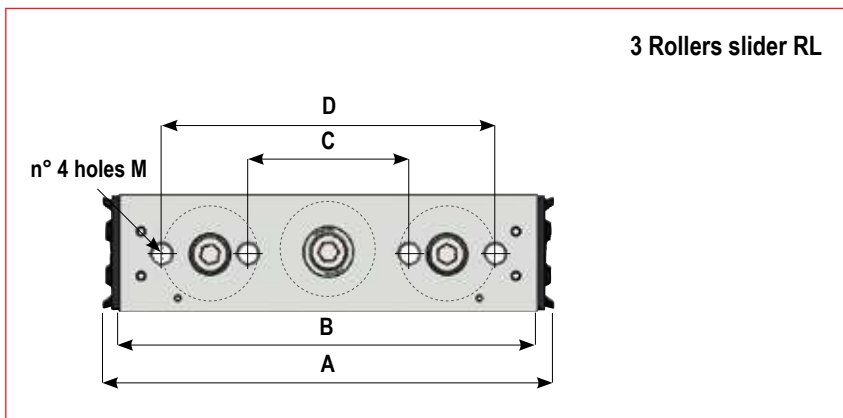
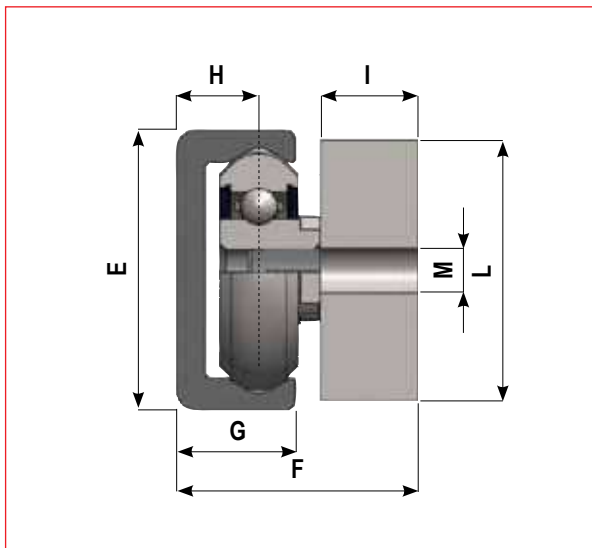

	Rail type	E (mm)	F (mm)	G (mm)	H (mm)	I (mm)	L (mm)	M (mm)	A (mm)	B (mm)	C (mm)	D (mm)	Weight (gr)	C (N)	Co rad (N)	Co ax (N)	Mx (Nm)	My (Nm)	Mz (Nm)
RL28-3	ML28	28	24	11	8,2	10	25	M5	105	97	35	78	220	4800	2000	750	5	13	27
RL28-5									151	143	25		330	6480	2700	1250	10	25	75
RL43-3	ML43	43	37	18,3	12,65	15	40	M8	152	143	55	114	700	11600	5000	1875	21	54	107
RL43-5									228	219	40		1070	15660	6750	3125	41	95	285

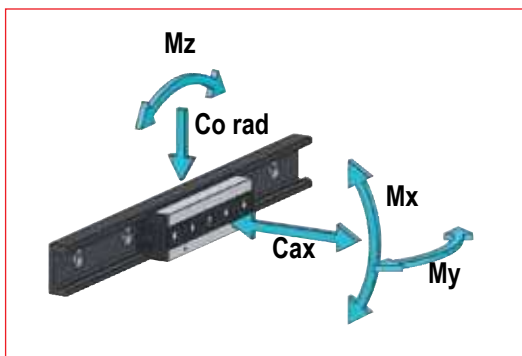

Guiding slider series RLS.

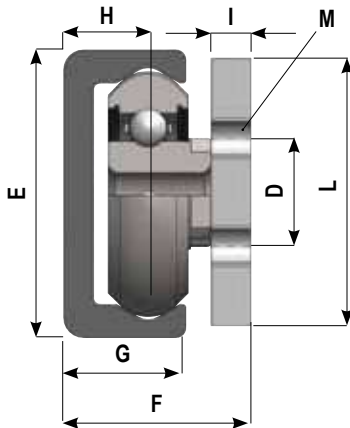

Version RLS-.. standard with threaded holes

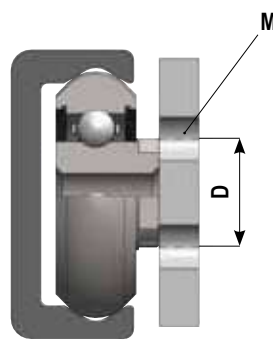

Version RLS-..C version with cylindrical holes

Very compact slider, with thin strong slider body, for application with limited space. Performance like standard RL-sliders. Featuring extra long 4-roller version to optimize performance with only 1 slider, instead of 2 sliders.

The sliders are available in standard version with threaded fixing holes RLS-.. and in version ...C with through passing holes for inside fixing with standard cylindrical screws DIN912, with no interference with the rollers.

Slider type	M	Type of fixing screws
RLS28-..	M5	
RLS28-..C	Ø 5,5	M5 DIN912
RLS43-..	M6	
RLS43-..C	Ø 6,5	M6 DIN912

3 Rollers slider RLS.

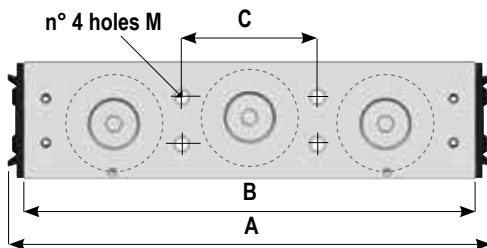

5 Rollers slider RLS.

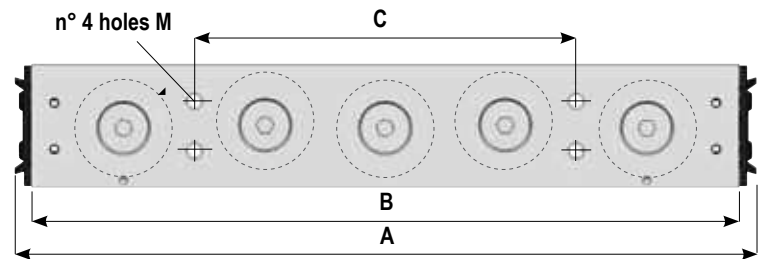

Long slider with 4 rollers RLS series

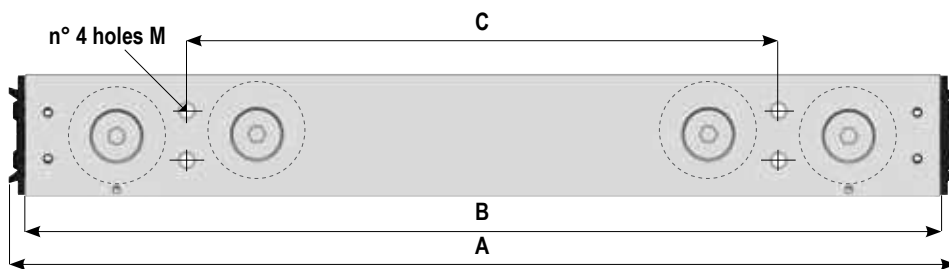

Example of order codes.

RVS28-3 : Guiding Slim-slider with 3 roller.

RPS43-4LC : Extra long rotation Slim-slider with 4rollers and cylindrical fixing holes.

RVSX28-5 : INOX guiding Slim-slider with 5 rollers.

Code	Rail type	E (mm)	F (mm)	G (mm)	H (mm)	I (mm)	L (mm)	M (mm)	A (mm)	B (mm)	C (mm)	D (mm)	Weight (gr)	C (N)	Co rad (N)	Co ax (N)	Mx (Nm)	My (Nm)	Mz (Nm)
RLS28-3	MR28	28	18,2	11	8,2	4	25	M5	118	108	32,5	10	140	4800	2000	750	5	16	32
RLS28-5									166	108	82	10	210	6480	2700	1250	10	28	82
RLS28-4L									210	200	126	10	230	4800	2000	1000	10	39	126
RLS43-3	MR43	43	28,2	18,3	12,65	6	40	M6	164	153	46	16	440	11600	5000	1875	19	57	115
RLS43-5									239	230	124	16	670	15660	6750	3125	37	106	310
RLS43-4L									311	300	194	16	750	11600	5000	2500	37	150	485

ROLLERS LINEAR SYSTEM

Sheet iron LAZ, LAX rails and PAZ, PAX sliders



LAZ series rails

LAX series rails and PAX series sliders are constructed entirely of stainless steel and are a simple and functional solution for applications that require high corrosion resistance.

The rails and sliders bodies are made from 300 Series stainless steel with rollers made from 440C.

These are particularly suitable for food processing, pharmaceutical, and medical applications or in difficult environments such as marine environments where there is exposure to highly corrosive agents.

The slider is equipped with 3 rollers. The middle roller is eccentric and is used to adjust the slider preload.

LAX series rails

LAZ series rails and PAZ series sliders are dimensionally identical to the LAX and PAX Series but are much lower in cost because they are made of Zinc plated steel.

The LA series is a simple and functional solution for linear motion. The minimum space requirements, internal protected raceways, ease of assembly, and good load capacity makes this linear bearing system an excellent choice compared to other solutions available on the market

Length L (mm)	
LAZ 26 LAX 26	LAZ 40 LAX 40
160	
240	
320	320
400	400
480	480
560	560
640	640
720	720
800	800
880	880
960	960
1040	1040
1120	1120
1200	1200
1280	1280
1360	1360
1440	1440
1520	1520
1600	1600
1680	1680
1760	1760
1840	1840
1920	1920
2000	2000
2080	2080
2160	2160
2240	2240
2320	2320
2400	2400
2480	2480
2560	2560
2640	2640
2720	2720
2800	2800
2880	2880
2960	2960
3040	3040
3120	3120
	3200
	3280
	3360
	3440
	3520
	3600
	3680
	3760
	3840
	3920
	4000

LAZ and LAX sheet iron rails

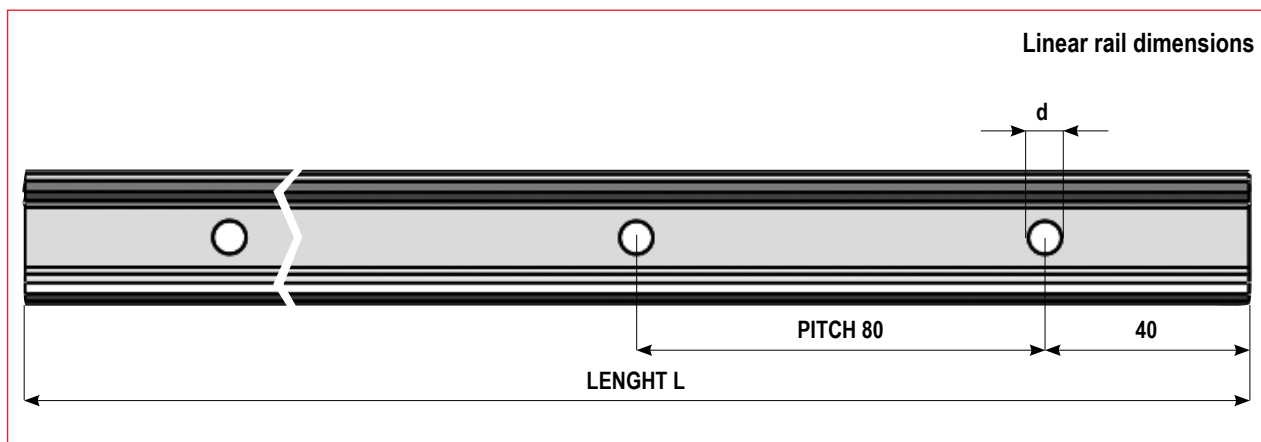

Rail code	A (mm)	B (mm)	C (mm)	d (mm)	E (mm)	Fixing screws	Weight (kg)
LAZ 26	26	14	9,5	6,5	2,5	M5 - ISO 7380	0,67
LAX 26							
LAZ 40	40	21,3	13,3	9	3	M8 - ISO 7380	1,55
LAX 40							

Suitable fixing screws of type ISO 7380

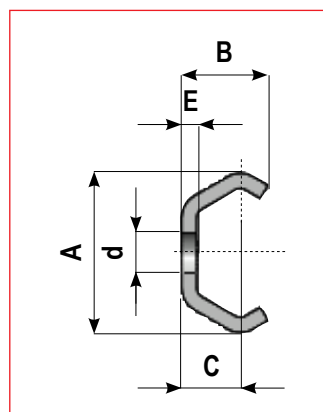

Sliders series PAZ26, PAX26 with 3 rollers

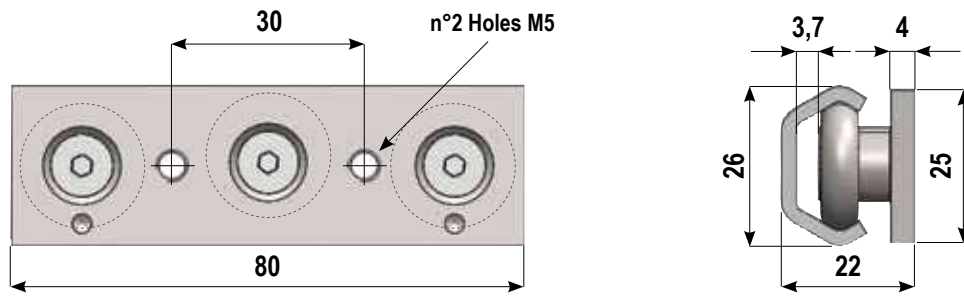

Slider	Co rad (N)	Co ax (N)	Mx (Nm)	My (Nm)	Mz (Nm)	Weight (gr)
PAZ26 PAX26	800	400	3	9	12	100

Sliders series PAZ40, PAX40 with 3 rollers

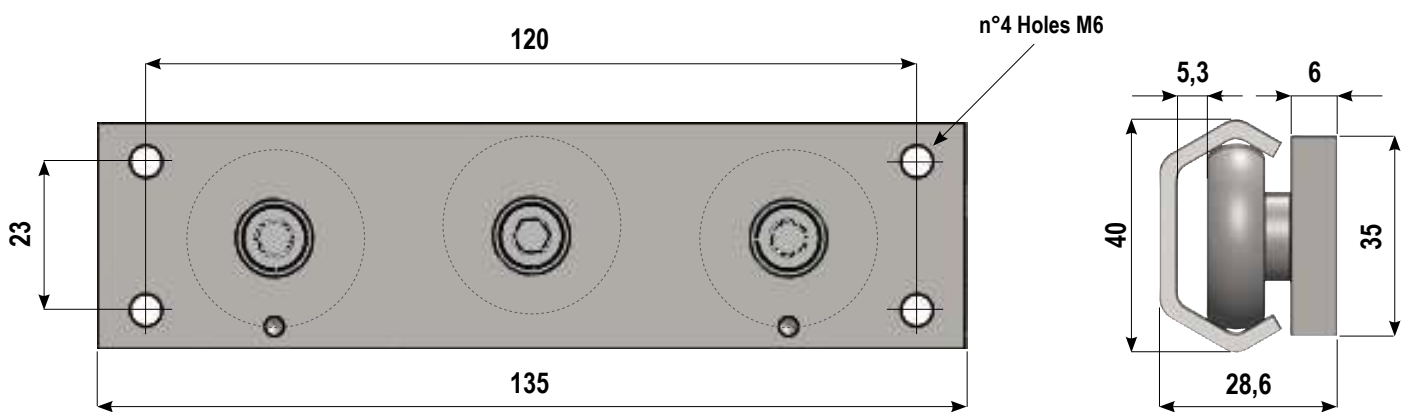

Sliders	Co rad (N)	Co ax (N)	Mx (Nm)	My (Nm)	Mz (Nm)	Weight (gr)
PAZ40 PAX40*	1600	800	9	23	32	430

* on demand

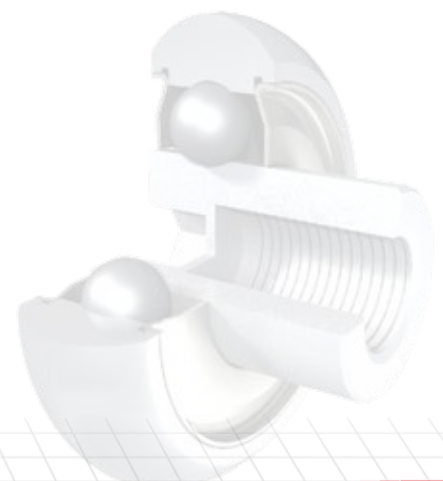
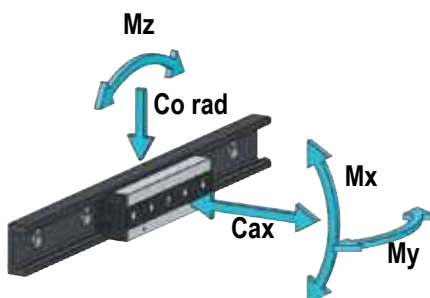

R. rollers for MR, FXR rails



The ROLLERACE rollers are designed around a double-row precision ball bearing to guarantee both high radial and axial load capacities. The rollers are protected by a double lip sealing system (2RS) to assure long lifetime, even in difficult environments. The integrated roller pivot has concentric or eccentric shape, to allow for preload setting in the different systems. The bearings are made to precision class DIN620 of core-hardened carbon steel. The rollers are available in series R.V with 2 contact points on the protruding raceways to obtain, a rigid guiding movement. The R.P are the rollers with some limited floating/compensation capacity, as only having one contact point at the central part of the raceways. The R.F rollers offer much more floating capacity, as one side completely flat (only rollers in size 43/63).

The rollers of size 28 and 43 are also available in INOX series R..X. All made from AISI440 steel, core hardened and ground, for applications in corrosive ambients.

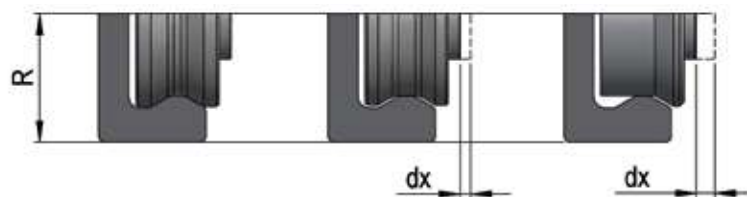

Only size 63

Guiding roller
R.V

Floating roller
R.P

Freely floating roller
R.F

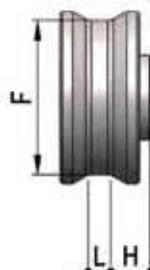
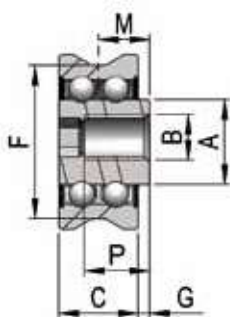
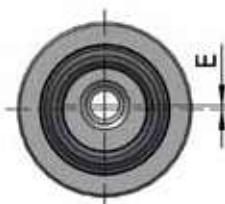
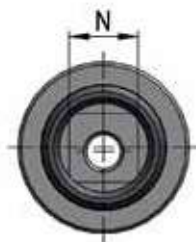

Roller code	Type	E (mm)	D (mm)	C (mm)	M (mm)	G (mm)	N Flat key	A (mm)	B (mm)	P (mm)	R (mm)	F (mm)	L (mm)	H (mm)	Version	Lateral floating δx	For rail	Load capacity (N)			Weight (gr)
																		C	Co rad	Co ax	
RCV18G	concentric	0	13,2	7,0	4,6	1,1	Allen key 3 mm	6,8	M4	5,4	8,8	11,9	2,5	3,4	guiding	1	MRG18	1650	800	230	10
REV18G	eccentric	0,4																			
RCP18G	concentric	0																			
REP18G	eccentric	0,4																			
RCV28	concentric	0	20,0	9,0	6,3	1,8	Allen key 4 mm	10,8	M5	7,0	13,9	17,6	3,0	4,8	guiding	1,2	MR28	3000	1600	460	20
RCV28X																					
REV28	eccentric	0,6																			
REV28X																					
RCP28	concentric	0																			
RCP28X																					
REP28	eccentric	0,6																			
REP28X																					
RCV43	concentric	0	30,8	14,0	9,0	2,0	Allen key 6 mm	15,0	M8	10,5	21,3	27,2	4,0	7,0	guiding	2*	MR43 FXR	7100	3600	1070	50
RCV43X																					
REV43	eccentric	0,8																			
REV43X																					
RCP43	concentric	0																			
RCP43X																					
REP43	eccentric	0,8																			
REP43X																					
RCF43	concentric	0	30,4									9,0	7,0	freely floating	4						
REF43	eccentric	0,8																			
RCV63	concentric	0																			
REV63	eccentric	1,2																			
RCP63	concentric	0	42,4	15,7	10,95	3,1	Flat key 17 Outer dim. for KMR 63	22,1	M10	18,8		38,4	10,6	8,2	guiding		FXR	11200	6400	2000	80
REF63	eccentric	1,2																			

1) Position R referred to FXR rail is indicated at page 18

L. rollers for ML rails

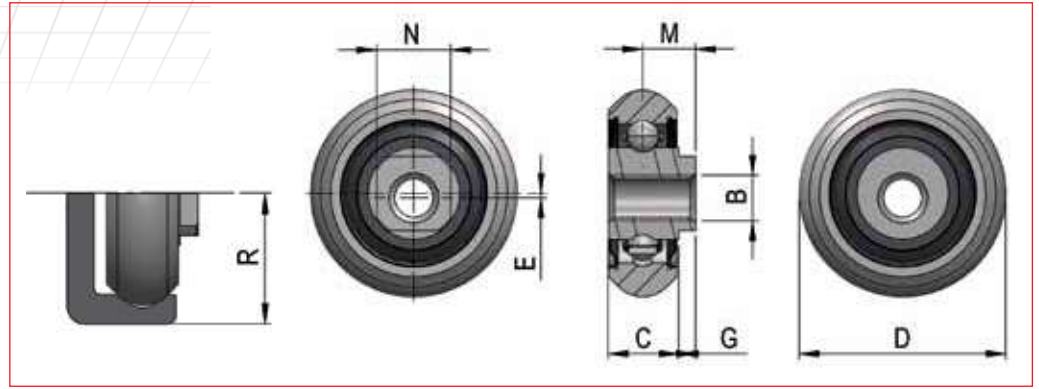
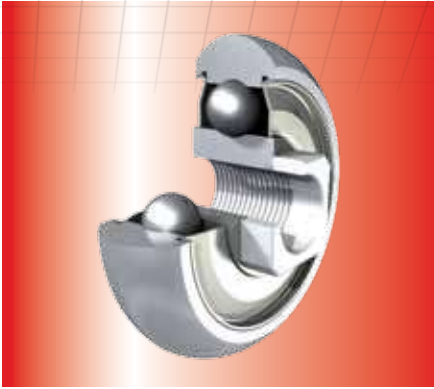

The rollers of series L.V and P.Z are single row bearings with 2Z steel seals.

The integrated roller pivot has concentric or eccentric shape, to allow for preload setting in the different systems.

The bearings are made to precision class DIN620 of core-hardened carbon steel.

The inner ball-retainer is too made of steel for high temperature applications to withstand high temperature.

Roller code	Type	E (mm)	D (mm)	C (mm)	M (mm)	G (mm)	N Flat key	B (mm)	R (mm)	For rail	Load capacity (N)			Weight (gr)
											C	Co rad	Co ax	
LCV28	concentric	0	23,5	7,0	5,9	2,4	Flat key Outer dim. 10 for KML 28	M5	14	ML28	2.400	1.000	250	20
LEV28	eccentric	0,6												
LCV43	concentric	0	36,0	11,0	9,4	4,85	Flat key Outer dim. 13 for KML 43	M8	22	ML43	5800	2500	625	50
LEV43	eccentric	0,8												



P. rollers for LA rails

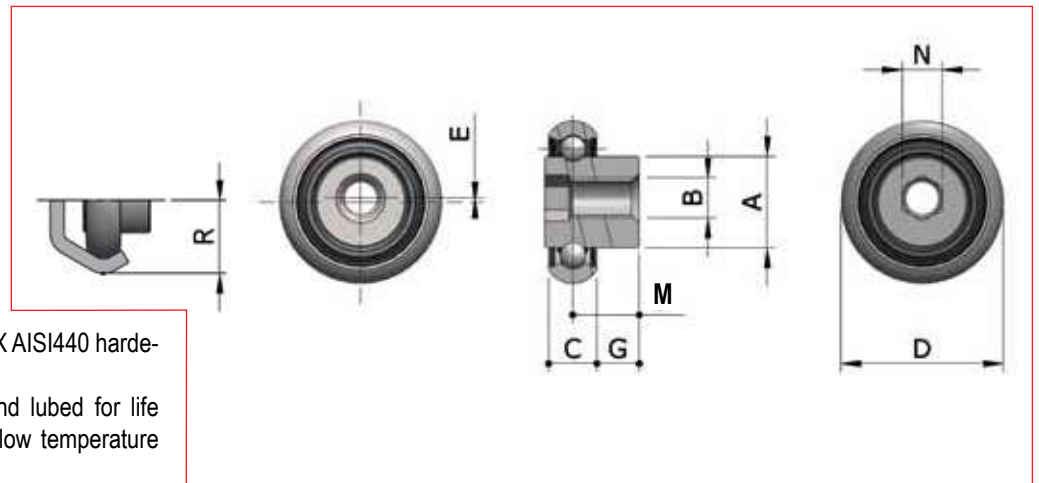

The rollers series P.. Are also available in INOX AISI440 hardened steel for corrosive ambients.

The INOX rollers comes with 2RS seals and lubed for life with mineral oil for alimentary application or low temperature applications.

Codice rotella	Tipo	E (mm)	D (mm)	C (mm)	M (mm)	G (mm)	N sede chiave	A (mm)	B (mm)	R (mm)	Per guida	Capacità di carico (N)			Peso (gr)
												C	Co rad	Co ax	
PCZ26	concentrica	0	20,3	6	8,5	5,5	esagono incassato Hex 3	11,2	M5	13	LAZ26	900	400	148	10
PEZ26	eccentrica	0,6													
PCX26	concentrica	0													
PEX26	eccentrica	0,6													
PCZ40	concentrica	0	32	10	9,65	4,65	esagono incassato Hex 5	15,0	M8	19,6	LAZ40	1800	800	296	40
PEZ40	eccentrica	0,8													
PCX40	concentrica	0													
PEX40	eccentrica	0,8													

FLEXRACE a very flexible linear system with unique assembly possibilities. The FLEXRACE system provides an extremely versatile linear system, with great variety of rail /roller configurations for a wide range of applications. FLEXRACE is designed to be a strong and simple multitask linear system for larger handling and automation applications. It is a Low -cost, easy to assemble system, that offers smooth motion even on inaccurate surfaces.

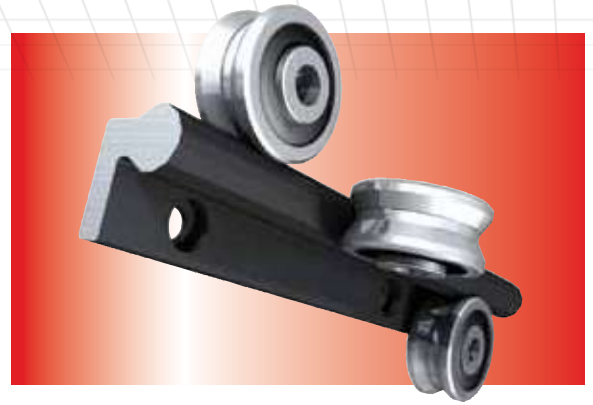

FXR rail with rollers

Depending on space and capacity requirements, two dimensions of rollers are available, size 43 - 63. The standard rollers are guiding of type R.V, but with use of the floating-rollers R.P43 or R.F43 and R.F63 a Selfaligning

system is easy obtained.

For corrosive ambients INOX rollers are too available in size

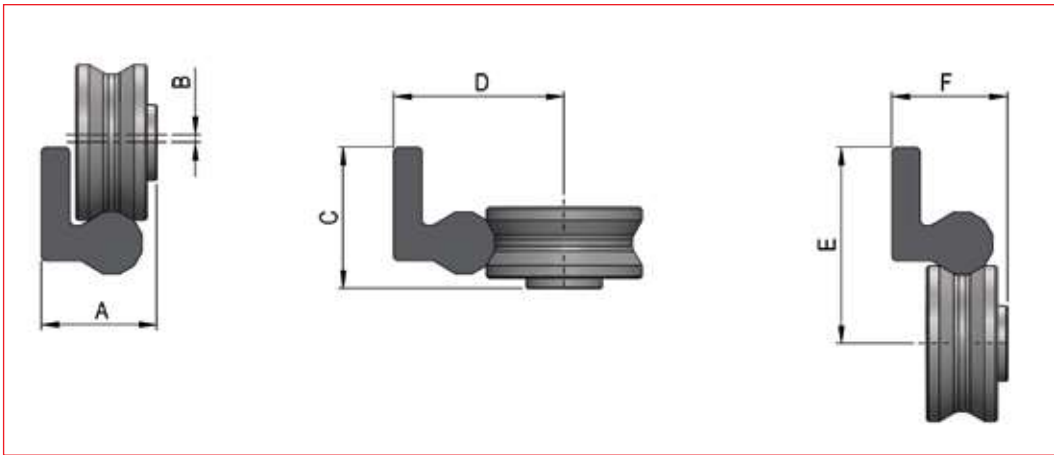

Possible roller positioning with FXR rail .

Roller type	A (mm)	B (mm)	C (mm)	D (mm)	E (mm)	F (mm)
R.V43	22,85	0,8	27,9	33,73	38,78	22,85
R.V63	24,8	1	29,85	39,41	44,46	24,8

For complete data and dimensions for rollers, please refer to page 16.

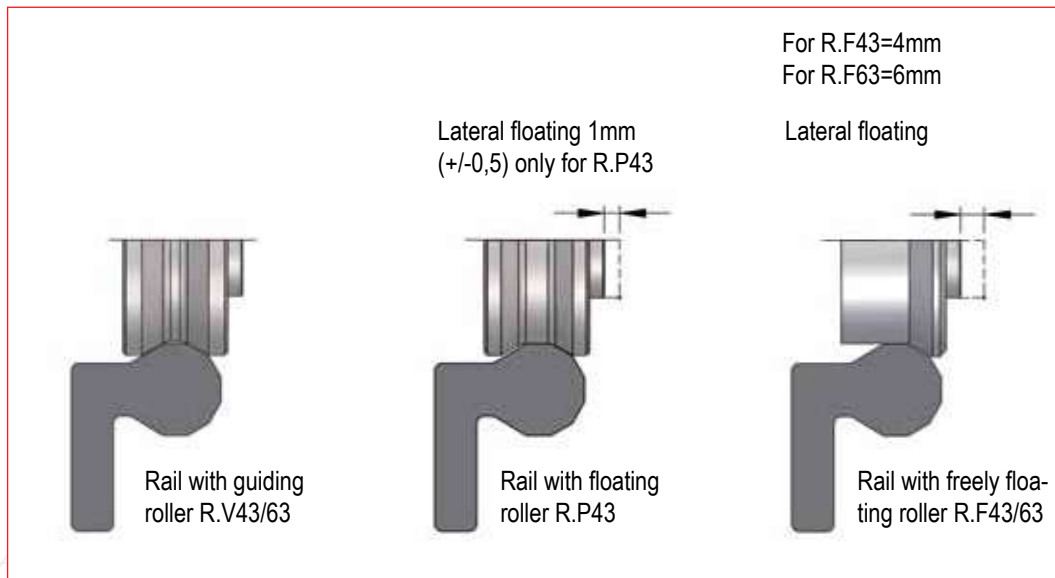

Rail with roller R.V63

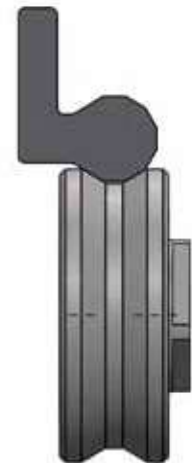

Rail with roller R.V43

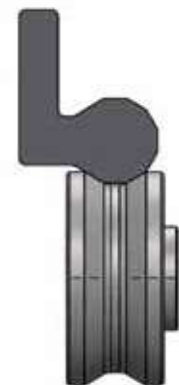

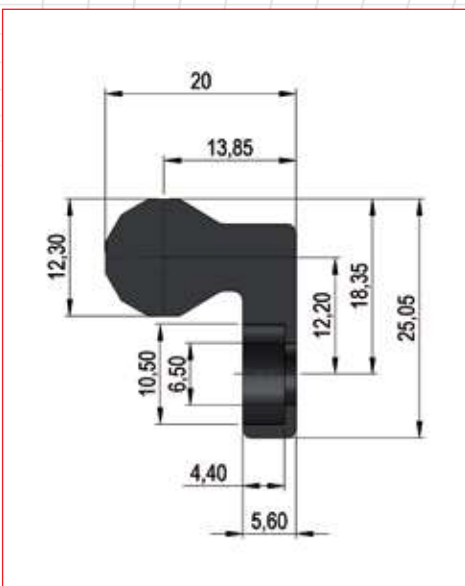

The rail is made from special carbon steel alloy to assure a good nitriding hardening with our T RACE-NOX treatment. An innovative hardening technology applied to the linear rail products able to increase the hardness on the surface and in depth, enough to guarantee to support the typical Hertz's stress in the point of contacts with the rollers, and to grant a strong resistant against corrosion, reducing the friction and the wear for a long life of the rail.

After nitriding hardening the rails are processed with an oxidation treatment and subsequently a hot-oil impregnation to assure a nice black color and a high corrosion resistance. It is available also the version FXR-P80 with holes pitches 80 mm, recommended for high load application.

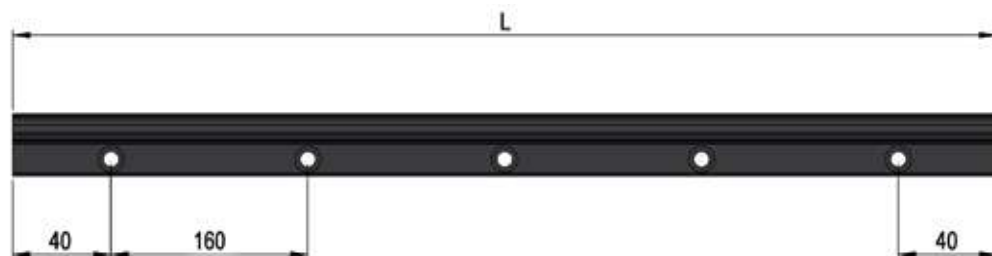

L (mm)												Weight (kg/m)
400	560	720	880	1040	1200	1360	1520	1680	1840	2000	2160	2,09
2320	2480	2640	2800	2960	3120	3280	3440	3600	3760	3920		

Roller positioning

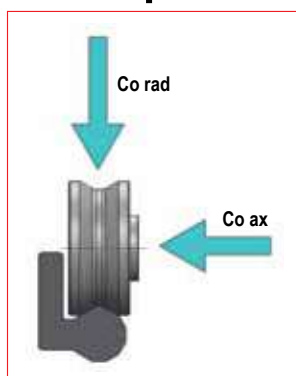

The roller must be correctly positioned with regards to load direction and too with sufficient number of rollers to assure requested load capacity and life-time.

The load capacities are listed on page 16. Generally it is always preferable to position the rollers so the main loads are acting radially on the rollers, as highest load capacity for the rollers, i.e. Co rad. Load capacity is higher than axial load capacity Co ax, as the axial load is only acting on one raceway, compared to two raceways for radial loads.

The rollers must be fixed to complete rigid and plan steel support and fixed with below indicated tightening torques for each type of rollers.

While fixing screw of the rollers, it is maintained blocked with the key on the rear-end, each type of rollers have its own key/tool.

When use of eccentric rollers it is suggested to use a spring-washer, between screw and roller, to facilitate the preload regulation before final tightening of roller.

The preloading of the eccentric rollers are done, like explained for the sliders on page 24

Roller type	Roller key	Screw type	Tightening torque (Nm)
R..18	Allenkey 3	M4	3
R..28	Allenkey 4	M5	7
R..43	Allenkey 6	M8	23
R..63	KMR63	M10	38
L..28	KLM28	M5	7
L..43	KLM43	M8	23
P..26	Allenkey 3	M5	7
P..40	Allenkey 5	M8	23

Lubrication of rails and rollers

A correct lubrication of rails and rollers is very important to assure long life of the products, in case of high frequency applications. In such cases it is suggested to clean raceways and rollers and re-lubricate every approx. 100.000 cycles, in normal operation conditions.

We suggest to use grease for high precision of type "Classe NLGI2 (ISO2137) .

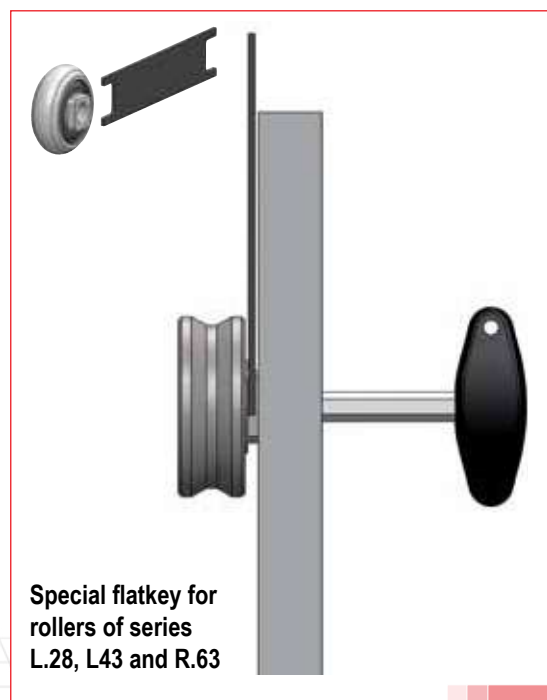
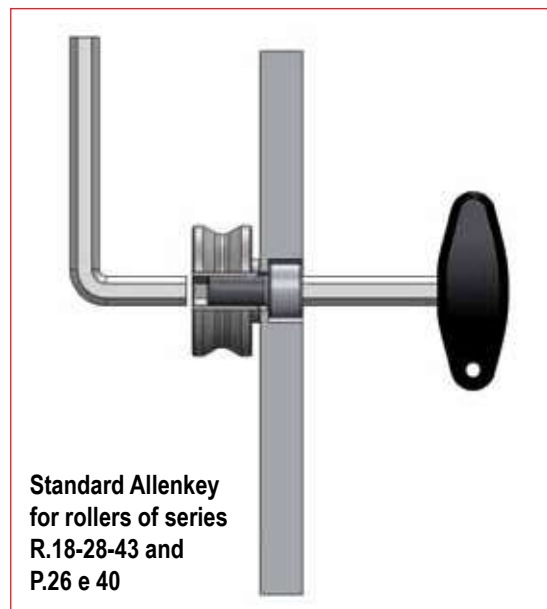

POSSIBLE CONFIGURATIONS WITH FXR RAILS

The FXR rail allows for many different rail configurations for linear moments with 2 or more parallel rails to plan or tubular supports, on which rollers or carriers are running. With its unique 3-raceways, compact and space saving linear solutions can be obtained. The below illustrate configurations are all customized solutions T RACE have been offering its customers and are made to order. Naturally these solutions can too be made locally by

end user, just buying the components, FXR rails and rollers. If requested support for dimensioning T RACE's Tech. off. can assist to assure correct dimensioning according to requested load/moment capacities. Main advantages are that linear solutions with high Mx moment capacities can easily be assembled. Solutions which too can to substitute a monorail solution with parallel rails.



Wide rail with inner carrier

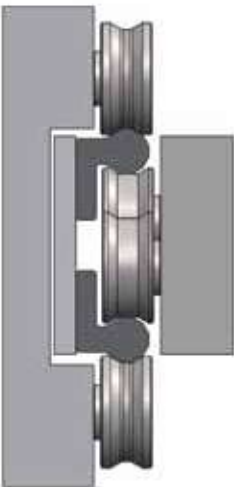

**Telescopic slide with rollers.
Two elements moving to assure
100% extension.**



Wide rail with outer carrier

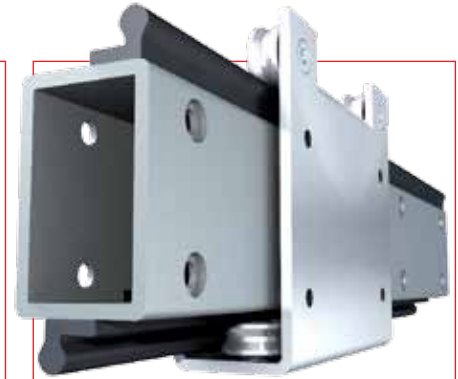
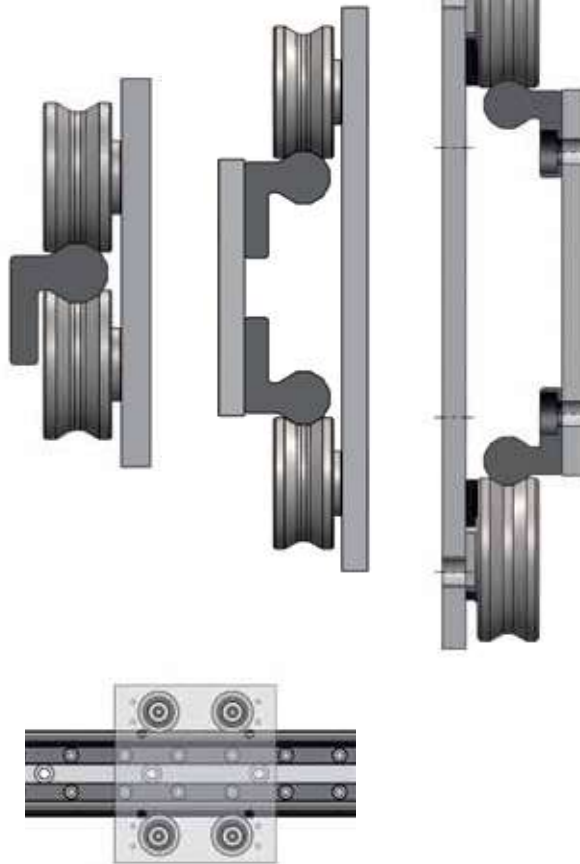

**Tubular rail with external
carrier for heavy loads/
moments.**

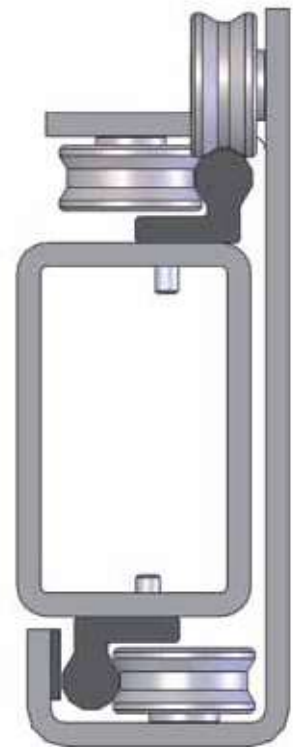

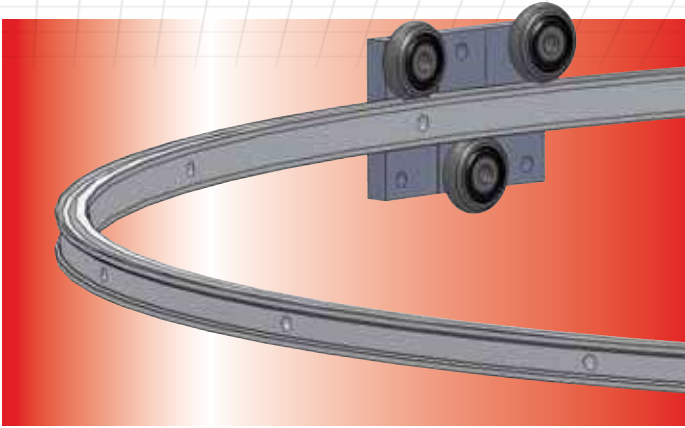

The curve rails of series BSC are made to customers request, based on required radius, not inferior of 500mm, see below table.

The curves radius is according to the requested angle a° with the limitation of lengths of one single rail-length. The rail is made from cold-drawn steel profiles with bright zink-plating. The rails radial fixing points are too customized according to below table.

On the rail is running 3-rollers sliders, which too is ordered on request, based on the radius. The rollers are single row bearings with 2Z seals.

To assure a good lifetime of the system, we propose to grease regularly, based on the frequency, with grease of type "Class NLGI2" (ISO2137)



Rail of series BSC

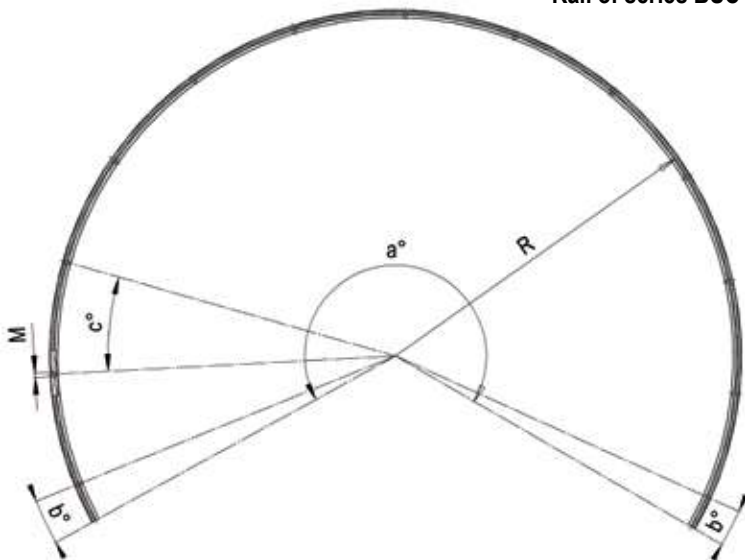

Rail code	Radius of curve R (mm)	Lengths of rails (mm)	Arch of curve a°	Rails fixing holes		
				position b°	pitch c°	M (mm)
BSC28	500 min	3000 max.		on request		\varnothing 5,5
BSC43	600 min	4000 max.		on request		\varnothing 6,5

The fixing holes are for screws with cylindrical heads, DIN

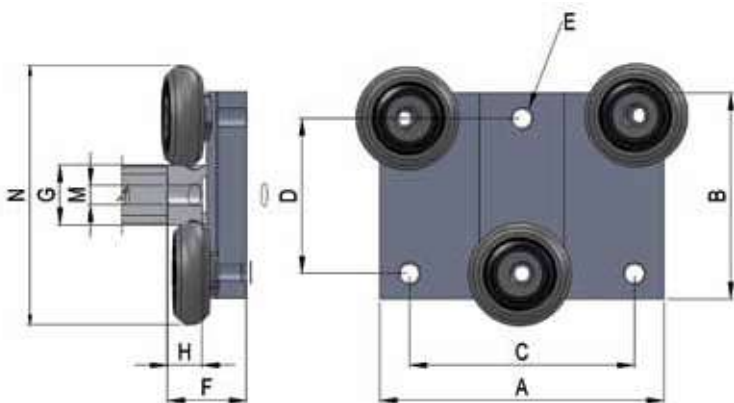

Slider series RBS

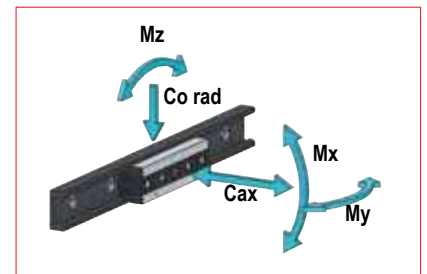

Rail code	A (mm)	B (mm)	C (mm)	D (mm)	F (mm)	N (mm)	H (mm)	G (mm)	E (mm)	Load capacity				
										Co rad	Co ax	Mx	My	Mx
RBS28-3	60	50	40	35	17,3	53,7	6,4	14,4	M5	800	400	2	6	8
RBS43-3	90	80	60	58	24,7	90,7	12,2	21	M6	1600	800	6	18	24

ASSEMBLY INSTRUCTIONS

Linear Rail Mounting

The availability of both countersunk (S-type) and counterbored (L-type) rail mounting holes allows optimization of alignment and orientation of the rails, depending on load direction and geometry.

Generally the countersunk S-type rail is mounted with flathead screws and does not require special alignment, because the taper of the fastener and rail mounting hole, forces a rail into a specific position. Such rail mounting holes, allow for easy and fast rail installation, however the precision of the tapped hole placement in the mounting surface will affect the position of the rail.

The counterbored holes in L-type rails allows for a small amount of lateral movement during installation.

This type of mounting is preferred when the tapped holes in the mounting surface are not precisely placed. This type of mounting holes are too necessary, when aligning the rail with an external reference surface, as the holes will allow the rail to move slightly, to seat against the reference surface.

The rail must be secured to a structure sufficiently rigid to support the full load. The surface mounting holes should include a chamfer as shown in the table.

Slider Assembly

R sliders for MR and ML rails, have threaded holes paralld with the holes of the rail and aligned within the tolerance shown on page 28. In case of more sliders in same rail, the misalignment of the fixing holes of various sliders is compensate by making a bit larger holes on the fixing structure.

It is recommended to only fully tightened the sliders mounting screws after installing all sliders in all the rails.

This allows the sliders to align to the rail, avoiding creating additional stress on the sliders. R_S and RLS sliders have a slim slider body and allow for double slider fixing, with either threaded holes (standard) or a through holes, by adding a "C" designation to the part number (i.e. RLS28C-3).

In case of through holes, it is advisable to drill some holes in the rail for access to the screws, for tightening after the sliders with screws are inserted into the rail. The RT sliders have mounting holes perpendicular to the rail mounting holes and offer the options of mounting from above or from below. In case where two sliders in respettive version A and B, are installed in same rail, it might be necessary to shim the slider body thicknesssupport, as eventual presence of minor misalignment (see tolerance on page 28) of slider body thickness.

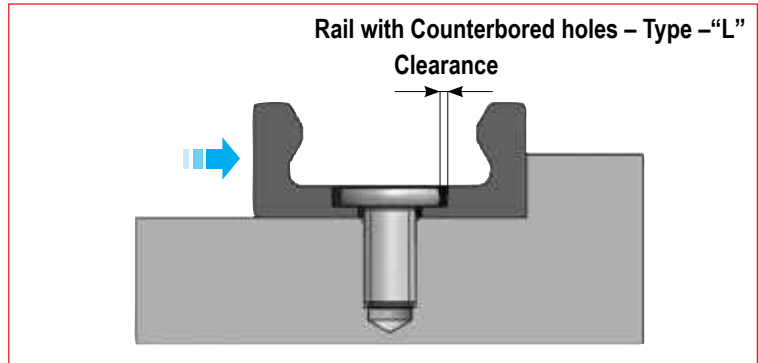
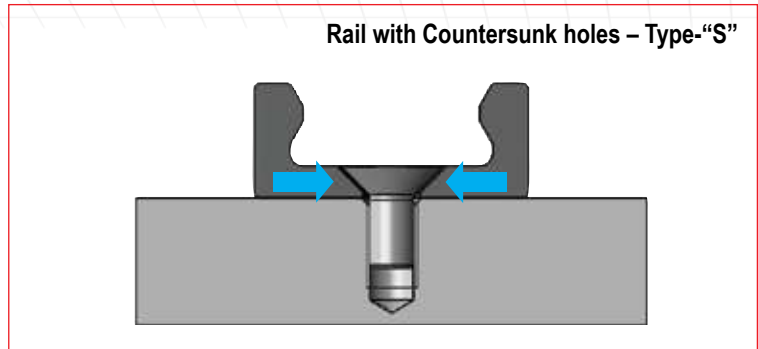

Rail type	Chamfer (mm)
MRG18	0.5x45°
MR28	1x45°
MR43	1.5x45°
ML28	1x45°
ML43	1.5x45°

Chamfer

Slider fixing for series R.

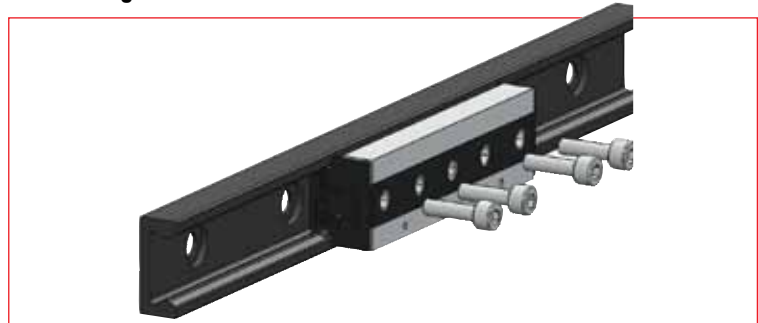

Slider fixing for series R.T

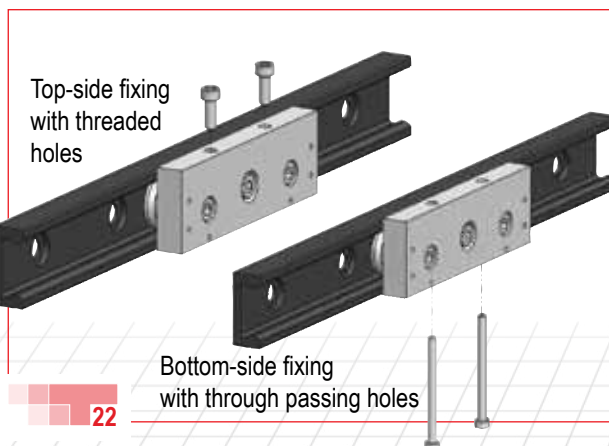

Slider fixing for series R.S

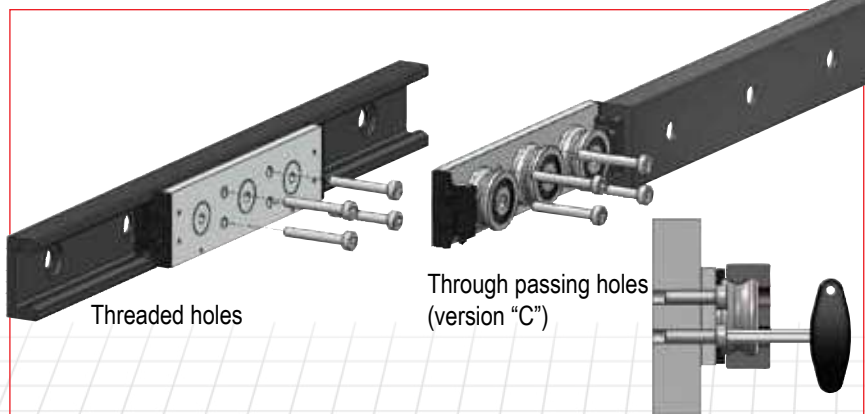

Examples of Mounting Arrangements

a) A pair of rails mounted on facing walls with S-type mounting holes, for fast installation. Combined with self-aligning RA sliders (rotating) and RP or RF sliders (floating), such linear system is capable to self adjust for some mm of parallelism errors between the two walls, see also page 21 for further info.

b) A pair of rails mounted to the same horizontal surface with "L" brackets to rotate the rails so they are loaded radially. "L" type counterbored holes are used to ensure full support of the rail on the horizontal surface. RVT sliders are fixed to a plate from above. Use of "L" type rails provides maximum rigidity of parallel rails.

c) Rails are mounted on perpendicular surfaces. The upper rail is of type S with countersunk holes for quick mounting and combined with a RAT slider to support the weight, but too for allowing some rotational movement. The lower rail is with counterbored holes to allow rail adjustment against the vertical surface and is combined with an RFS slider to allow for unlimited vertical compensation. The system simplifies installation and allows alignment of the rails on both the vertical plane and horizontal plane.

d) Rails are mounted flat on a horizontal surface and loaded axially. The two rails are "L" type with counterbored mounting holes to allow proper rail alignment. One of the two rails should be pushed against a lateral support for precise alignment of the movement's linearity. The sliders are fixed to a carriage plate and the second rail is fastened in place while moving the carriage assembly along the full travel to ensure parallelism of the rails. The RV-sliders offer maximum stiffness and load capacity in the axial direction

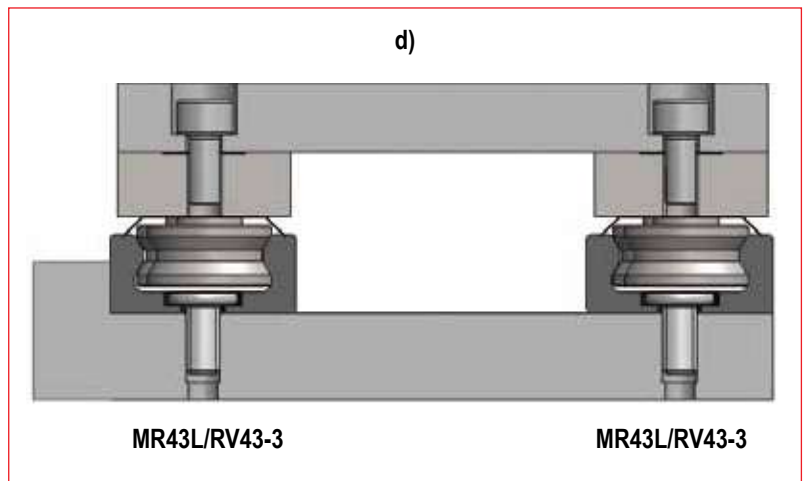
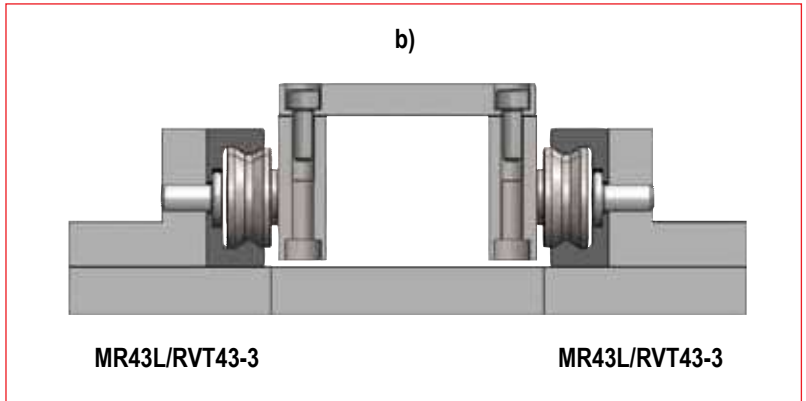
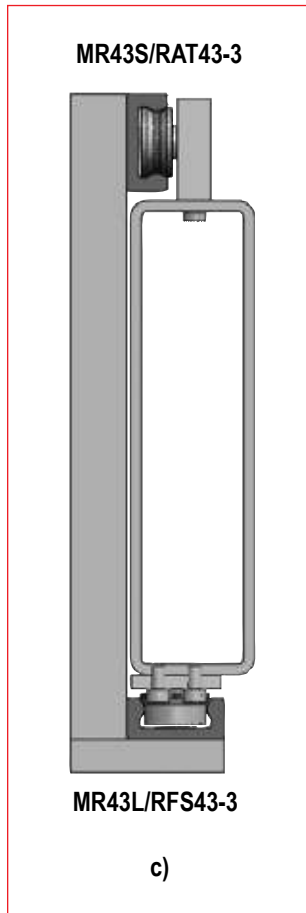
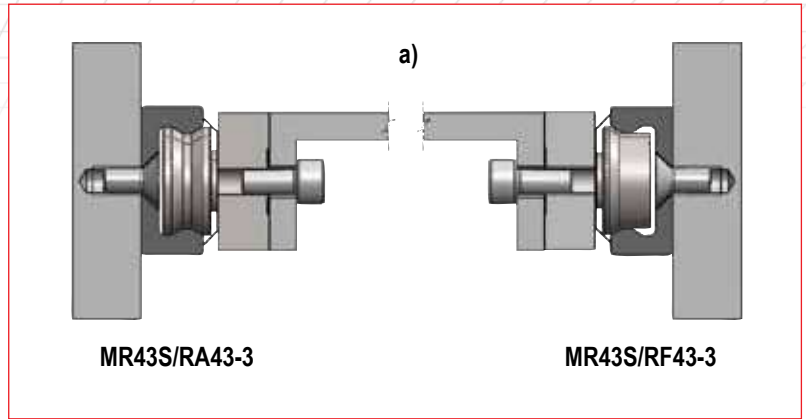

SLIDER ORIENTATION

Sliders with 3 and 5 rollers provide maximum load capacity in the radial direction with the greater number of rollers on the same raceway of the rail. The side is marked with two circular impressions on the slider body. For example, sliders carrying a load as shown in the picture below should be oriented with the marks opposite the load direction. The marks indicate where the maximum reaction force is available.

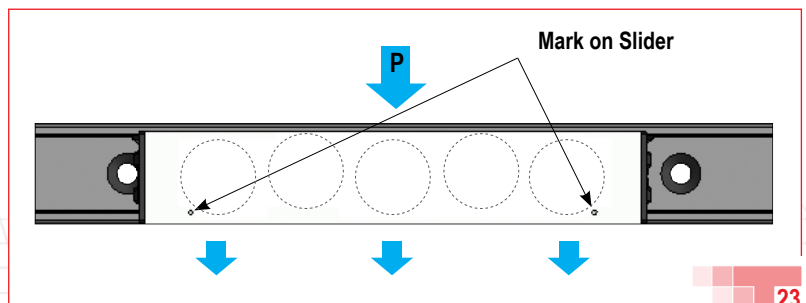
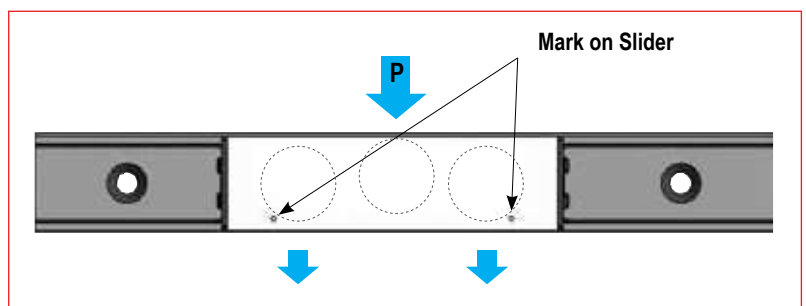
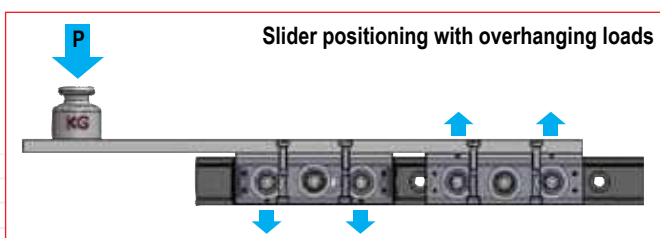

PRELOAD SETTING OF SLIDERS

When the sliders are ordered mounted in rail, the preload setting is done in factory, with our regulation instruments to assure a standard light preload P1, to assure no play and with optimal smooth running.

As there might be minor differences of internal raceway distance, between same type of rails, already preload set sliders should not be used for other rails. I.e. each slider must be preload set to each rail.

When sliders are purchased separately from the rail, the preload setting is done according to below procedure, depending on whether the slider is type R_ or RL or LA. Preload setting is permitted for all sliders by the eccentric roller; one for 3 roller-sliders or two eccentric rollers in case of 5 roller-sliders. The adjustable eccentric rollers should be in contact with the opposite raceway of the fixed-rollers, which are all concentric rollers :

Procedure for preload setting of sliders serie R.

To make the preload setting, one must act on the top screw, tightening the eccentric wheel (only accessible screw left on the top cover band) and the pivot of the eccentric roller, - on the other side. 2 Allen keys are needed.

1 - Verify that the raceways are clean, take the wipers off, to obtain a more sensitive feeling for correct preload setting and smooth running.

2 - Tighten the top-screw, but not too much, to allow a firm turning of the eccentric bottom-pivot, maintaining the roller tight to slider body.

3 - Turn the eccentric pivot so that the roller is roughly aligned with the concentric rollers or slightly in the opposite direction of the concentric rollers.

4 - Block the rail on a stable support, so hands are free. Insert the slider into the rail. Insert the Allen key into the pivot, through the rail fixing hole. Turn the Allen key slightly, so that the eccentric roller is coming in light contact with the raceways, opposite the fixed rollers. During the rotation, accompany the top-screw while rotating in the same direction with second Allen key, in order to avoid any loosening or change in preload setting.

5 - Move the slider along the whole rail lengths to find the part/point, where the slider moves with less friction/most oscillations. By pressing/pulling the slider ends, any oscillation is detected. If any oscillation/play is noted, the eccentric roller must be re-adjusted. Perfect preload setting is achieved, when the slider moves very smoothly and with no play at this point, with "widest" raceway distance.

The checking for oscillation is not possible for type: RA rotation slider or floating sliders RP, RF.

6 - Holding firm against the Allen key, engaged in eccentric pivot with one hand, while with other Allen key rotate and tighten the top-screw fastening the roller. **WARNING!** Do not lock or unlock the eccentric roller by turning the pivot, always and only act on the top-screw for blocking/loosening the roller.

7 - It's possible to verify the amount of preload by slowly inserting the slider at the end. The inserting force F_i is proportional to the preload. In general a good setting correspond to the following min/max. forces shown in Table 6b.

8 - Then make final roller/screw blocking using a torque wrench, to assure right closing torque (M_t) according to the values in Table 7b, while maintaining the Allen key in pivot, to prevent any change of preload setting.

For 5-roller sliders, the above steps are repeated for each of the two eccentric rollers. When adjusting the second eccentric roller, it is necessary to visually assure, that the roller has got in contact with the raceway, to hereby rotate in opposite direction, compared to the fixed rollers, when moving the slider. This can be seen through the rails fixing holes.

The homogeneity of preload setting, between the two eccentric rollers, can be verified by simply inserting the slider with the other end, i.e. after turning the slider 180 degrees. **WARNING!** After preload setting, assure that slider is inserted with fixed rollers positioned in direction of applied load.

In case the rail is already installed, so no longer accessible from behind, the preload is set outside the rail, by tentatively positioning of the eccentric roller in more steps, to finally obtain a smooth moving with no slider oscillation in the installed rail.

Preload setting of sliders series R.

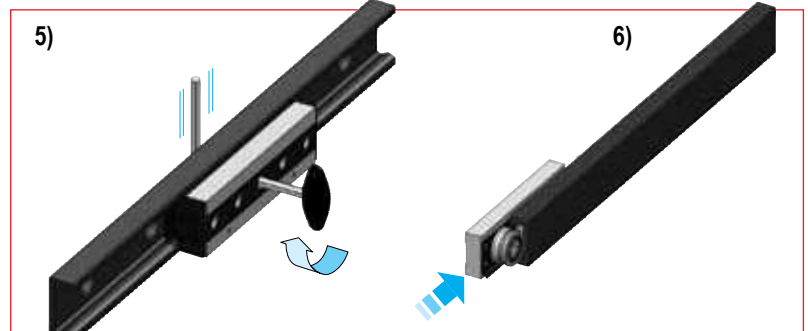
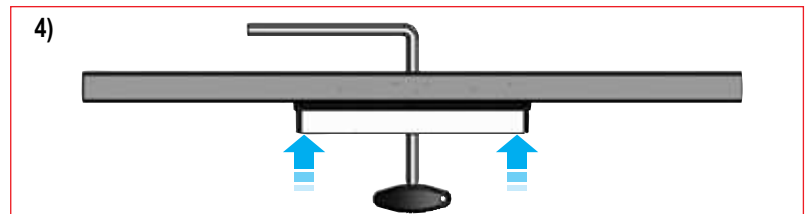
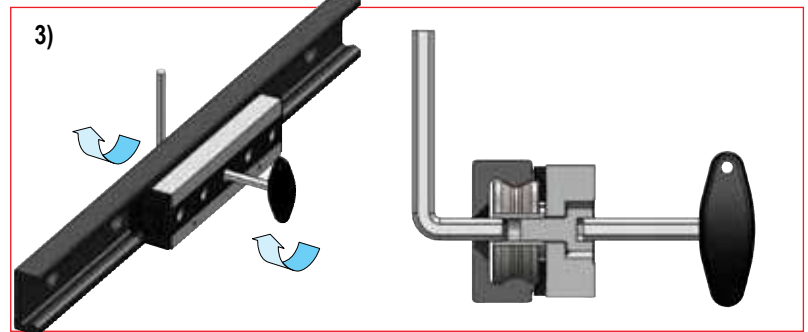
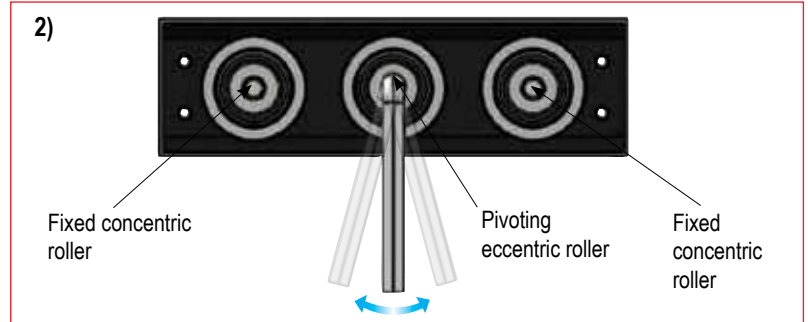
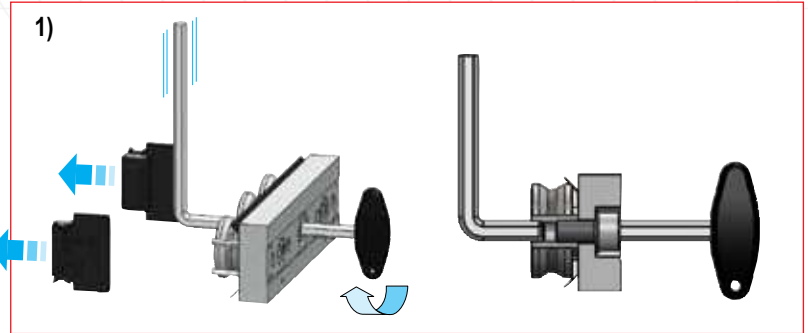

Slider type	Fi - Inserting force	
	min	max
R.18	0,5 N	2 N
R.28	1 N	5 N
R.43	2 N	10 N

Slider type	Mt - Tightning torque
R.18	3 Nm
R.28	9 Nm
R.43	22 Nm

Procedure for preload setting of sliders serie PAZ, PAX .

The PAZ/PAX sliders, like the R-sliders, have the preload setting done by adjustments of the central roller with eccentric pivot.

The preload setting is done with 2 Allen keys and is similar to R-sliders, described on page 19. The closing torque M_t and inserting force for these sliders are shown in below tables.

Slider type	Mt - Tightning torque
PAZ/PAX 26	7 Nm
PAZ/PAX 40	23 Nm

Slider type	Fi - Inserting force	
	min	max
PAZ/PAX 26	1 N	5 N
PAZ/PAX 40	1 N	5 N

Procedure for preload setting of sliders series RL.

The RL sliders have unlike the R series, a special central square pivot accessible with a flat key inserted between slider body and actual roller. With this flat key, provided by TRACE, the correct preload setting is done following the concepts of adjustments described in page 19. While having the slider already inserted in rail.

With this pivot concept, slider preload setting is too possible, while having both rail and slider already been installed.

Preload setting of slider series PA.

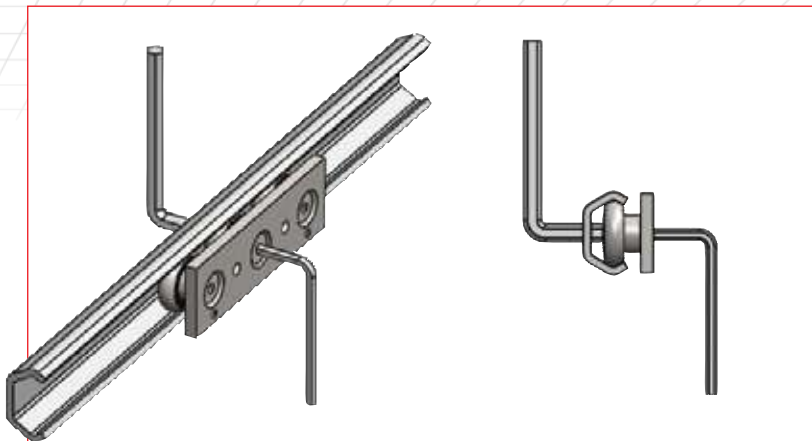

Preload setting of slider series RL.

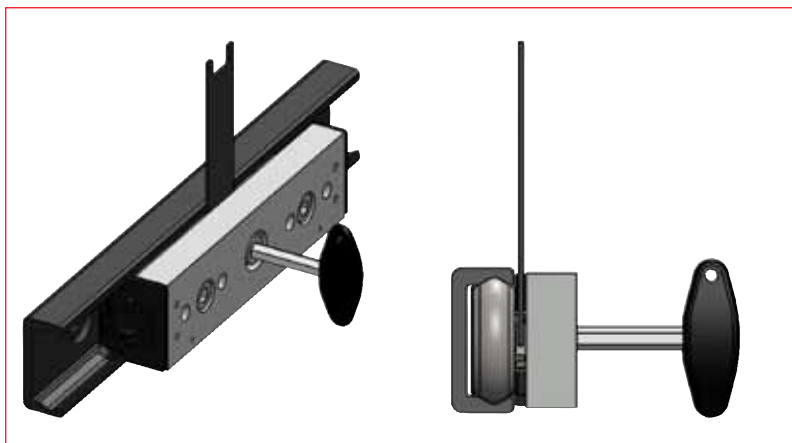

Regulation key KML

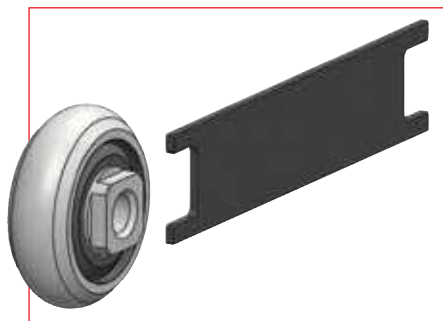

Wipers for replacement series KT.



Slider type	Mt - Tightning torque
RL28	7 Nm
RL43	23 Nm

Slider type	Fi - Inserting force	
	min	max
RL28	1 N	5 N
RL43	2 N	10 N

The flat key for preload setting of RL-sliders is supplied free of charge, on request. NB two type of keys, ref. Below table.

Slider type	Code for flat key
RL28	KML28
RL43	KML43



LUBRICATION OF RACEWAYS

All sliders, except PAZ and PAX series, are supplied with strong wipers with incorporated pre-oiled spunch, to provide a good greasing for a long period of operation. See table a right side for wiper codes for all sliders. The duration of this self-lubrificazion depends on the employmental conditions and the level of environmental pollution. Usually under normal conditions, the self-lubricant wipers can last about 700 km, however they can easily be replaced with a kit of new wipers with spunch.

The rollers are all, lubricated for life with grease of lithium type soap. The R_sliders have 2RS seals, while RL-sliders have metal ZZ seals.

Lubrication is very important to assure a long operation life. For applications with high frequency and continuous movement, it is advisable to regularly clean the raceways and relubricate the sliders for every 100,000 cycles, depending on the operation environment. Grease of class NLGI2 (ISO 2137) is then recommended.

Wiper codes	Slider type
KT- 18	R.18
KT-28	R.28, R. T28
KT-43	R.43, R. T43
KTL-28	RL28
KTL-43	RL43
KTS-28	R. S28
KTS-43	R. S43
KTLS-28	RLS28
KTLS-43	RLS43

SPLICED RAILS, COMPOSED OF SHORTER PRESELECTED RAILS

MR and ML rails can be supplied in longer lengths than offered in catalog, by splicing multiple rail segments together. These spliced rails must be ordered from the factory, while specifying the total length and the lengths of individual segments : "Example: MR43-6000 (4000 + 2000)" The spliced rail will be delivered in preselected segments length and with additional counterbored mounting holes added to the joining locations, in addition to ground ends.

The customer must add additional mounting holes in his structure for these additional holes at the joining location. End-screws for joining is too supplied free, same type as the standard screws for rails with cylindrical fixing holes.

To assure a correct alignment of the rail ends, an appropriate alignment tool can be purchased as a separate item. See drawing/table for product description and codes, at right side.

Alignment tool for spliced rails DAGA.

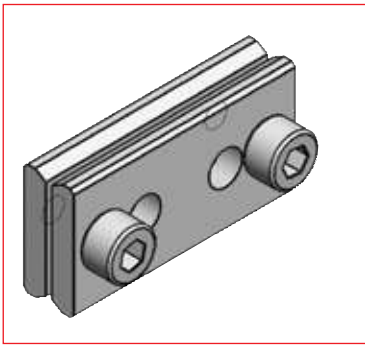

Joining area for spliced rails

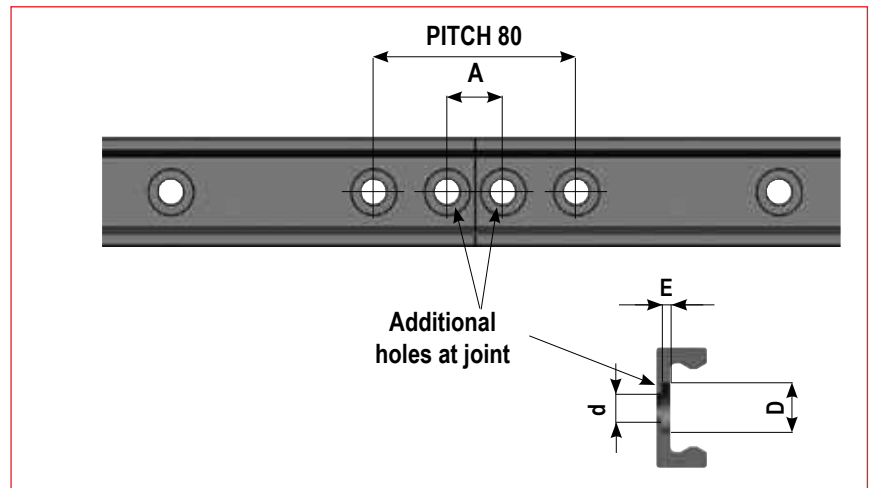

Rail type	Joining screws	Alignment tool	A	D	d	E
MRG18	M4-TORX SP	DAGA-MR18	16	9	5	1,9
MR28	M5-TORX SP	DAGA-MR28	16	11	6	2
MR43	M8-TORX SP	DAGA-MR43	22	18	10	3,2
ML28	M5-TORX SP	DAGA-ML28	16	11	6	2
ML43	M8-TORX SP	DAGA-ML43	22	18	10	3,2
FXR	M6-DIN 7984	DAGA-FXR	20	10,5	6,5	4,4

Installation instructions for rails composed of more lengths

- 1) Begin by supporting the two rail segments at the splice location. Develop a support guide in the area of joining lengths. Insert the alignment tool DAGA from one end of the rail. Install the mounting screws including the two at the splice location, but do not fully tighten them, to allow for small rail movements.
- 2) Place the alignment tool over the splice. Tighten the alignment tool screws to align the rail segments.
- 3) Verify that rail mounting surfaces (back side and lateral side of the rail) are aligned. If not, it may be necessary by use of shims, to maintain alignment after the mounting bolts are tightened and the alignment tool is removed.
- 4) Tighten the bolts at the splice location by passing the Allen key through the holes in the alignment tool. Tighten the other mounting bolts in the rails.
- 5) Loosen the alignment tool and remove it from one end.

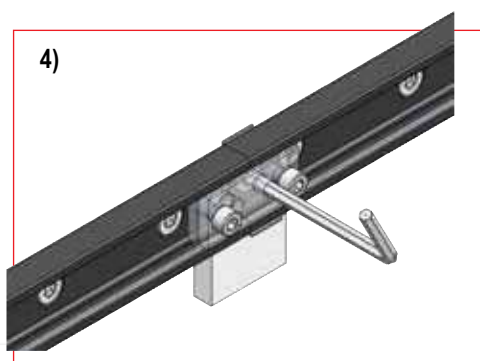
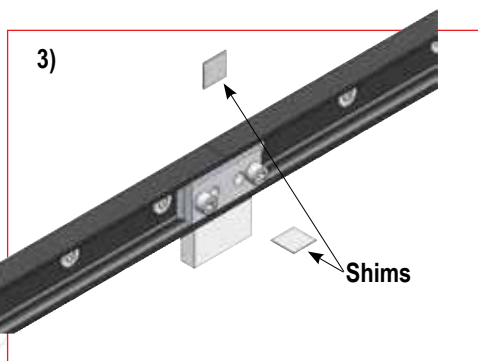
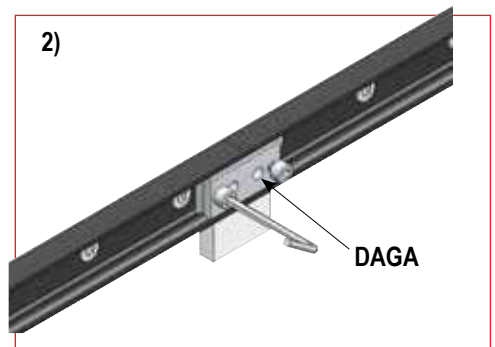
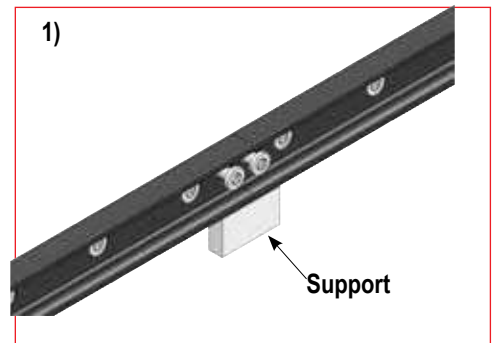

THRUST FORCE

The force required to move a slider is contingent on several factors, which are summarized to each other in relation to the application. I.e. the actual load applied, the direction of the load, the preload setting of the slider, friction of wipers/lateral seals and bearing seals. In principle the slider, when preload in rail without a load applied, may require a thrust force of F_w , which is mainly due to the preload setting, than friction caused by wipers. Especially the friction generated by wipers/lateral seals/preoiled spunchs tends to decrease after an initial period, as adapting their shapes the raceways. If removing the wipers, the thrust force F_o is then only based on the slider preload setting. The thrust force from slider preload setting may varie along the rail, due to minor paralllism tolerance of the rails internal raceways.

The thrust force F_t of the slider with a radial load P applied, is approximately proportional to the load as a coefficient function of friction μ of the wheels, increased by the thrust force F_w from wipers and preload setting.

$$F_t = (P \times \mu) + F_w$$

In case that slider is without wipers the value F_t results by:

$$F_t = (P \times \mu) + F_o$$

The below table shows the indicative values of F_w and F_o of a minimum value and a maximum value, depending on the preload setting of the slider. The result of F_t simplified formula is reasonably valid for applied loads greater than 10% of the maximum permissible load. For lower loads the coefferente of friction μ is increased up to twice the original value.

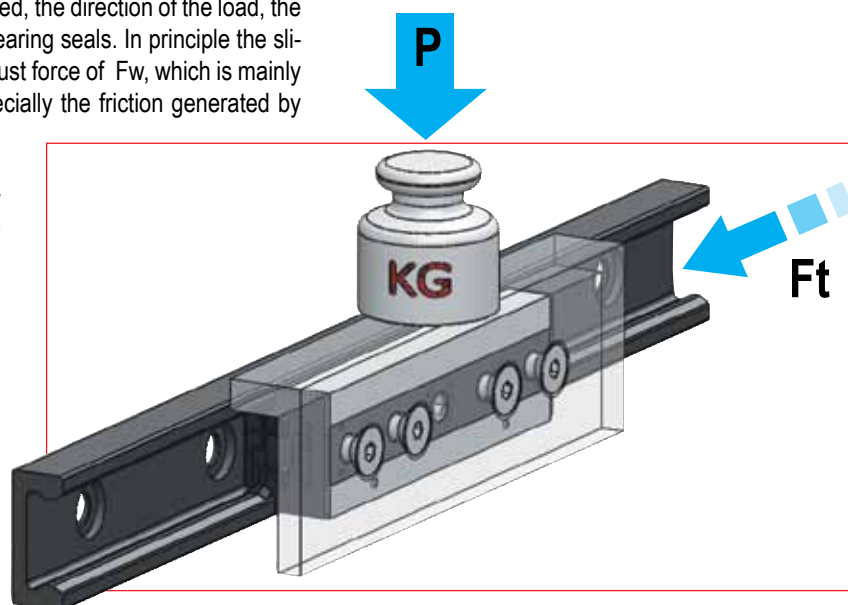

Slider type	F_o Static friction of slider without load and without wipers	F_w Static friction of slider without load and with wipers	μ Friction coefficient of rollers
R.18	da 0,2 N a 0,5 N	da 1 N a 1,5 N	0,005
R.28	da 0,5 N a 1,5 N	da 2,5 N a 3,5 N	0,005
R.43	da 1 N a 3,5 N	da 6 N a 10 N	0,005
RL/RLS/R.S28	da 0,5 N a 1,5 N	da 2,5 N a 3,5 N	0,005
RL/RLS/R.S43	da 1 N a 3,5 N	da 6 N a 10 N	0,005
PAZ-PAX	da 0,1 N a 0,6 N		0,008

NOISE AND SPEED

T RACE's roller sliders offer high operating speed up to 10m/s, with almost no noise, when compared to recirculating ball-sliders.

The table on right side, shows the max. speed for different slider types.

The R sliders with wipers and lateral seals, may emit a minor friction noise at no applied load, which however tends to decrease during use, as the parts adapt to the shapes of the raceways

Slider type	Max. speed
R.18	5 m/s
R.28	7 m/s
R.43	10 m/s
RL/RLS/R.S28	7 m/s
RL/RLS/R.S43	10 m/s
PAZ-PAX	5 m/s

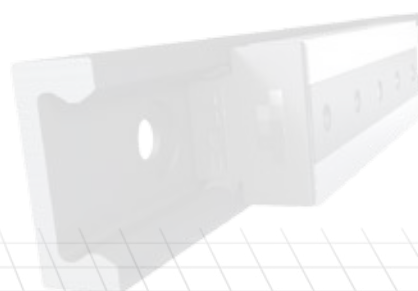

CONSTRUCTION TOLERANCES

The construction tolerances for the assembled dimensions of rails with their relative sliders are shown in below table. This too in relation to the rail mounting hole tolerances and mounting holes of the sliders.

In particular, it is necessary to take into account the possibility that the axis of slider symmetry, may be slightly misaligned with the axis of symmetry

of the rails. This mismatch may be larger in case of use of two sliders in same rail, of which one is positioned with load direction in opposite load directions.

This misalignments can be compensated while making the fixing holes slightly larger on both fixed and mobile parts.

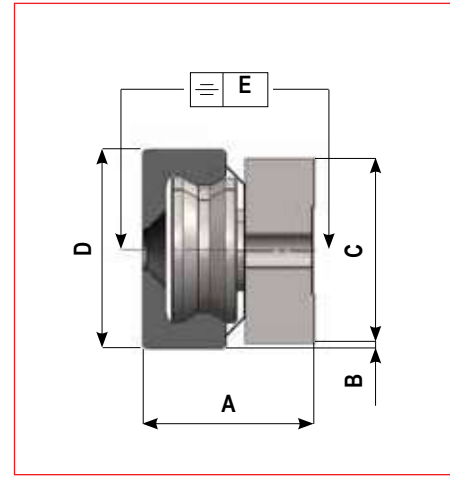
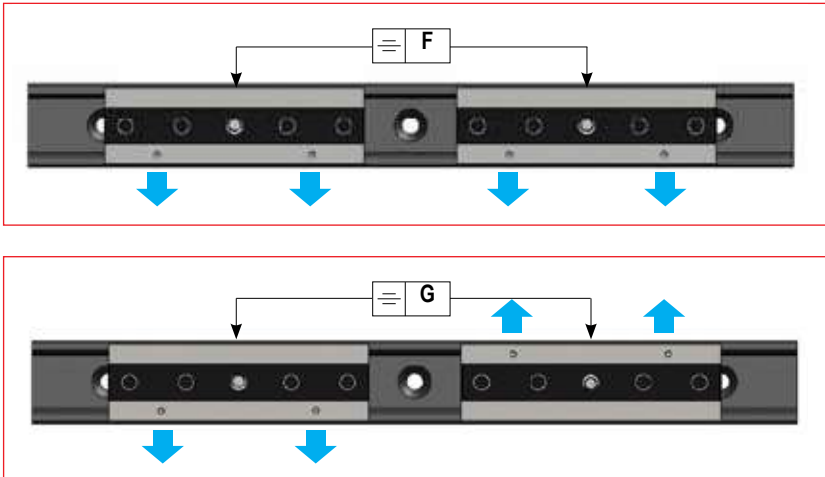

Rail type	Slider type	Tolerance						
		A	B	C	D	E	F	G
MRG18	R.G18	+0,15/-0,1	+0,2/-0,25	+0,05/-0,05	+0,2/-0,2	+0,3/-0,35	0,2	0,8
MR28	R.28	+0,15/-0,1	+0,2/-0,25	+0,05/-0,05	+0,2/-0,2	+0,3/-0,35	0,2	0,8
	R.S28	+0,1/-0,15	+0,25/-0,25	0/-0,1	+0,2/-0,2	+0,35/-0,35	0,3	1,0
	R.T28	+0,1/-0,15	+0,25/-0,25	0/-0,1	+0,2/-0,2		0,2	0,8
MR43	R.43	+0,15/-0,1	+0,2/-0,25	+0,05/-0,05	+0,2/-0,2	+0,3/-0,35	0,2	0,8
	R.S43	+0,1/-0,15	+0,25/-0,25	0/-0,1	+0,2/-0,2	+0,3/-0,35	0,3	1,0
	R.T43	+0,1/-0,15	+0,25/-0,25	0/-0,1	+0,2/-0,2		0,2	0,8
ML28	RL28	+0,1/-0,15	+0,25/-0,25	0/-0,1	+0,2/-0,2	+0,35/-0,35	0,2	1,0
	RLS28	+0,1/-0,15	+0,25/-0,25	0/-0,1	+0,2/-0,2	+0,35/-0,35	0,2	1,0
ML43	RL43	+0,1/-0,15	+0,25/-0,25	0/-0,1	+0,2/-0,2	+0,35/-0,35	0,2	1,0
	RLS43	+0,1/-0,15	+0,25/-0,25	0/-0,1	+0,2/-0,2	+0,35/-0,35	0,2	1,0
LAZ26, LAX26	PAZ26, PAX26	+0,25/-0,25	+0,4/-0,4	0/-0,1	+0,3/-0,3	+0,5/-0,5	0,3	1,0
LAZ40, LAX40	PAZ40, PAX40	+0,25/-0,25	+0,4/-0,4	0/-0,1	+0,3/-0,3	+0,5/-0,5	0,3	1,0

Linear Precision

The linear precision as the deviation of the sliders actual trajectory in relation to a theoretical straight line, is determined by the straightness of the surface in which the rail is fixed and the intrinsic precision of the rail. In reference to the linear precision of the sole rail, it is determined by the parallelism of the slider movement with respect to the two longitudinal planes of the rail, plan A and B.

The values of A and B are shown in the below chart, as a function of the rail length = actual slider movement.

The linear accuracy indicated in relation to plane A, is only achievable if the rail is fixed onto a perfectly straight/flat surfaces, using all mounting holes. The linear accuracy indicated in relation to the side B is achievable only for rails with counterbored mounting holes, of series "L", after having aligned the rail against a perfectly straight reference side. In case rails with c'sunk mounting holes is used, the linear precision is related to the straightness of the structures mounting holes.

The guide does not set free may not be perfectly straight (slightly arched on plan A) with no problem once and be clamped to a rigid structure.

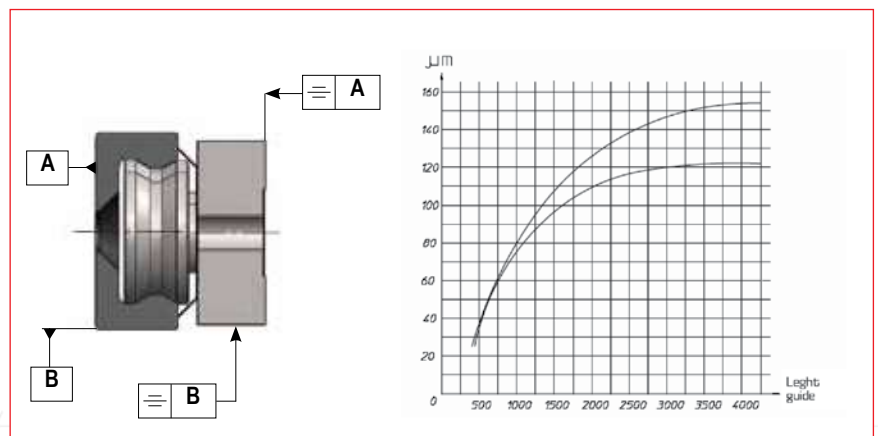

ASSEMBLY TOLERANCES FOR TWO PARALLEL RAILS

When two rails are used in parallel, it is necessary that the structure surfaces on which the rails are fixed, are parallel on different levels, with tolerance values within the figures given in below chart.

Errors of parallelism greater than the values listed may cause additional load on rollers and rails, which hereby reduce the nominal load capacity and expected life-time (see coefficient of use page 30). In case particularly high error values, it may too compromise the functionality movement.

The MR rails combined with sliders of type RA, RP or RF can compensate larger mounting errors, due to the rollers contact geometry (see page 3).

Hereby such Selfaligning system, can within certain limits, avoid additional load on rollers, which otherwise could compromise correct function of the linear system.

The rails of series ML and LA do not provide such geometry Selfaligning compensation, but they are structurally more flexible (bearings with single row of balls, rails with less rigid raceways as thinner) and hereby able to accept a reasonable error of parallelism, corresponding to an additional internal load, when the errors are within the values listed in below chart.

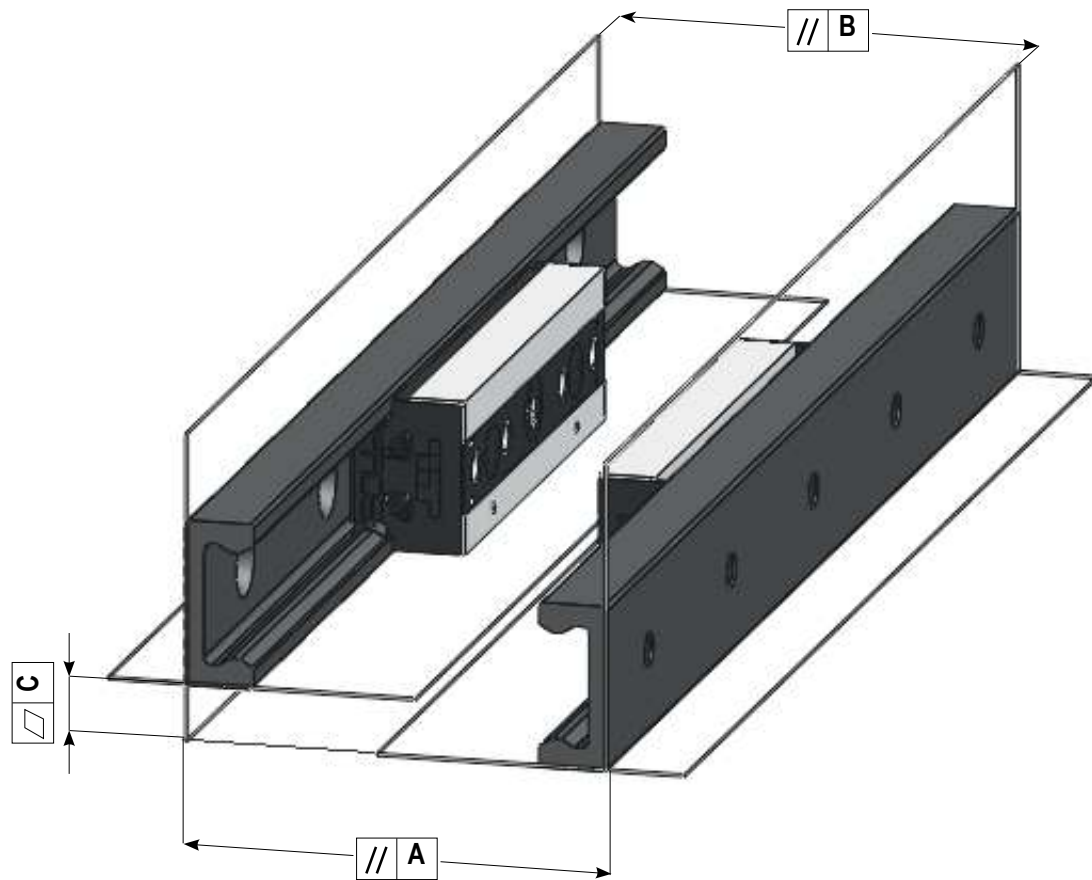

Pair of parallel rails	Slider combination		Acceptable parallelism error (mm)		
	Sliders in rail A	Sliders in rail B	Between level A	Between level B	Between level C
MRG18	RVG18	RVG18	0,03	0,02	0,5
	RAG18	RPG18	1	0,4	8
MR28	RV28, RVS28	RV28, RVS28	0,04	0,02	0,6
	RA28, RAS28	RP28, RPS28	1,2	0,5	9
	RA28, RAS28	RF28, RFS28	3	0,5	8
MR43	RV43, RVS43	RV43, RVS43	0,05	0,04	0,7
	RA43, RAS43	RP43, RPS43	2	0,6	10
	RA43, RAS43	RF43, RFS43	4	0,6	10
ML28	RL28, RLS28	RL28, RLS28	0,07	0,04	0,8
ML43	RL43, RLS43	RL43, RLS43	0,09	0,06	0,8
LAZ,LAX	PAZ, PAX	PAZ, PAX	0,2	0,2	1

SIZING VERIFICATION

After identifying the most appropriate positioning of rails and sliders, or eventually the single rollers, is it necessary to verify the proper sizing of the linear components. This both from a static point of view and in accordance to the expected life-time. For the static verification it is necessary to determine the load on each slider or roller, and then identify the mostly stressed one. Then verify the values of the safety coefficients, while comparing with the max. nominal load capacities. When the applied load is a combination of loads; radial and/or axial loads, and moments, it is necessary to determine the value of each factor and verify that:

$$\frac{P_{ax}}{Co_{ax}} + \frac{P_{rad}}{Co_{rad}} + \frac{M_{ax}}{M_x} + \frac{M_{ay}}{M_y} + \frac{M_{az}}{M_z} \leq \frac{1}{Z}$$

- P_{ax} = axial load component
- P_{rad} = radial load component
- M_{ax}, M_{ay}, M_{az} = applied moments
- Co_{ax} = axial load capacity
- Co_{rad} = radial load capacity
- M_x, M_y, M_z = resistance capacity to moments
- Z = safety coefficient $> = 1$

The radial load capacity for all sliders is the side with 2 engraved marks, - ref. page 23.

Load direction

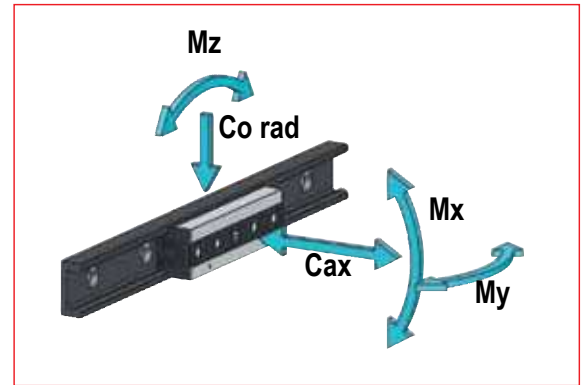

It is recommended to apply the following values to safety coefficient Z:

Z	Application conditions
1 - 1,5	Accurate determination of static and dynamic loads. Precise assembly, tight structure.
1,5 - 2	Average conditions
2 - 3,5	Insufficient determination of applied loads. Vibrations, loose structure. Imprecise assembly. Unfavourable environmental conditions.

Lifetime calculation

The lifetime of rollers and rail's raceways, is determined by the applied load and as a function of the actual stroke, the lubrication of raceways and by environmental factors. Indicatively the life-time determination in km is obtained by below conventional formular.

$$L (Km) = 100 \cdot \left(\frac{C}{P} \right)^3 \cdot \frac{f_c}{n} \cdot f_a$$

dove:

- C = Dynamic load coefficient of slider
- P = The equivalent load applied on the most stressed slider

Verified for each single slider

$$- P = P_{rad} + \left(\frac{P_{ax}}{Co_{ax}} + \frac{M_{ax}}{M_x} + \frac{M_{ay}}{M_y} + \frac{M_{az}}{M_z} \right) \cdot Co_{rad}$$

- F_c = Coefficient depending on the actual stroke length. This factor takes into account applications with short stroke. With value 1 the stroke is superior to 2m, with shorter stroke the value is less, ref "Graph Coefficient Fc"

- n = Number of sliders in same rail passing same raceway point

- f_a = Coefficient taking into account operational ambient and level of correct lubrication of raceways

Coefficient f_c

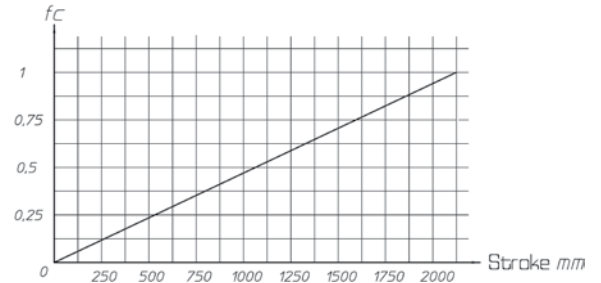

f_a	Application conditions
0,7 - 1	Good lubrication and wipers mounted – No impurities on raceways – Correct installation
0,2 - 0,5	Normal dusty factory ambient, some vibrations, temperature changes, no wipers
0,05 - 0,1	Poor Lubrication, dusty ambient, vibrations, high temperature changes, no wipers

MATERIALS AND TREATMENTS

The MR and ML rails are both high precision cold drawn profiles, produced from specific carbon steel to provide high dept hardness, by nitriding hardening treatment. This innovative process is called T-NOX, and is developed by T RACE to assure high hardness, low wear and a high resistance to corrosion.

This chemical heat treatment is conducted in three phases:

- 1) High nitriding depth
- 2) Black oxidation
- 3) Impregnation with corrosion inhibitors and mineral oil.

The T NOX treatment is done on the complete rail surfaces, to also provide high corrosion protection on the raceways.

Rails	Materials	Treatments
Serie MR	Steel for nitriding	nitriding
Serie ML	Steel for nitriding	nitriding
Serie LAZ	Steel	Zink plating
Serie LAX	INOX steel AISI 303	non

The sliders use different materials according to below table

Material	Slider					
	Serie R.	Serie R.T, R.S	Serie RL, RLS	Serie PAZ	Serie R.SX	Serie PAX
Slider body	Zink plated steel	Zink plated steel	Zink plated steel	Zink plated steel	INOX steel AISI 303	
Lateral seals	Polycarbonate	non	non	non	non	non
Wipers	Polycarbonate elastomer	Polycarbonate elastomer	Polycarbonate elastomer	non	Polycarbonate elastomer	non
Pre-oiled spunch	Sintetic fibre with bearing oil			non	Sintetic fibre with bearing oil	non
Screws	Zink plated steel			INOX steel		
Pins and spring washer	Spring steel			non	INOX steel	non
Washer	Hardened steel			Acciaio inox AISI440C		
Bearing seals	Neopren		Zink plated steel		Neopren	
Bearing cage	Poliammide		Zink plated steel		Poliammide	



WORKING TEMPERATURE

The operation temperature for sliders are -30° / $+130^{\circ}$ Celsius, for which max, temperature is limited by the 2RS seals. For the sliders RL. and PAZ, with 2Z seals the max operation temperature is 170° .

On request special greased rollers can be supplied for higher/lower temperature.