

SITEX® ST COUPLINGS



DRIVE  
SOLUTIONS

SITEX® ST



## SITEX® ST couplings

SITEX® ST couplings are fully manufactured in high quality steel. They are made of 1 or 2 geared hubs which are coupled with one sleeve through which the torque is transmitted.

The special **OPTIGEAR** profile allows very high torque transmission and the compensation of axial, angular and radial misalignment (only in the version with 2 hubs). The maximum recommended working temperature is -10 °C to + 80 °C.

For special applications special materials should be used. Please contact our technical department for information.

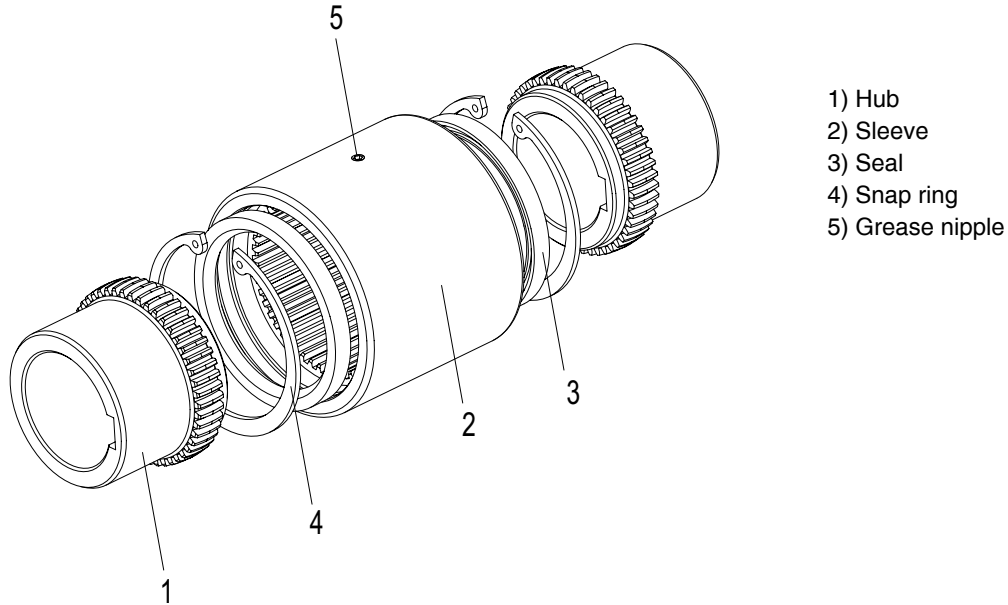

### Features

With the special design of the **OPTIGEAR** crown, the contact surface area under misalignment is larger than conventional crown. Therefore, the surface stresses are reduced resulting in a longer coupling life. Therefore, backlash is reduced to a minimum, reducing impact load in reverse application, and allow optimum torque transmission and low vibration. All this results in an improved machine design.

### OPTIGEAR profile

SITEX® ST couplings are machined with the unique **OPTIGEAR** profile, that allows backlash reduced to a minimum reducing impact load in reverse applications and allow optimum torque transmission and low vibration. The machine design is then optimized by using the most compact solution in coupling.

### Interchangeability

The range GST CF “A-B-C” conforms to **AGMA** specification in flange dimensions, type and positions of the screws. They are, therefore, interchangeable with any other AGMA coupling half.

The most compact solution

Due to the exceptional torque transmission capability, SITEX® ST couplings are the most compact solution in weight and dimensions for a safe torque transmission.

### Special executions

Special executions are available for any application need. Accurate finite element analysis can be made for special high demanding applications.

### Corrosion protection

SITEX® ST couplings are protected against corrosion with a special surface treatment. Mounting and dismounting are, therefore, guaranteed even after many years of use in difficult environment conditions.

**Note:** It is possible to have aligned keyways upon inquiry.



## SITEX® ST executions

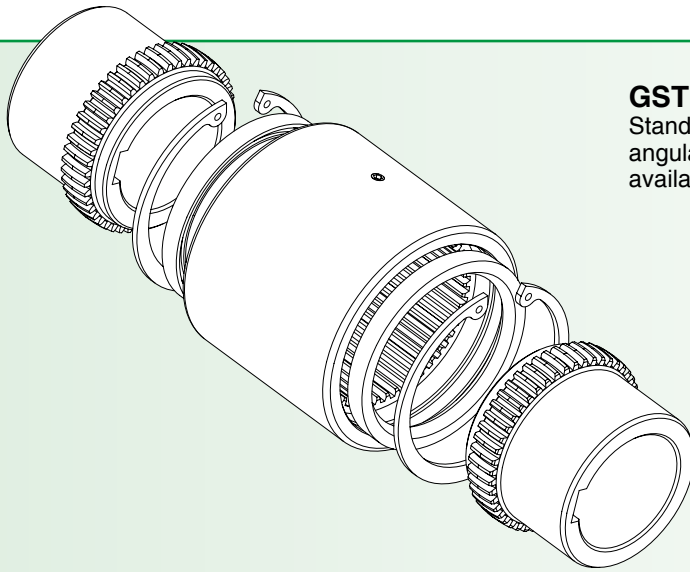

### GST type C

Standard type with 2 hubs and one sleeve. Allows for axial, angular, and radial misalignment. Long hub version also available. Offers compact, powerful design, and easy assembly.

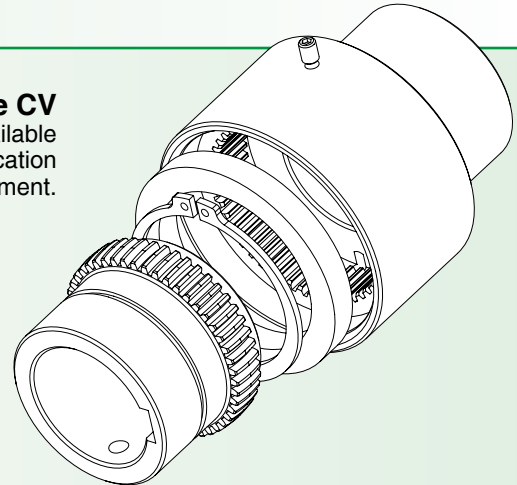

### GST type CV

Standard type made of a single hub and one sleeve. It is also available in long hub execution. Offers an economical solution to an application without radial misalignment.

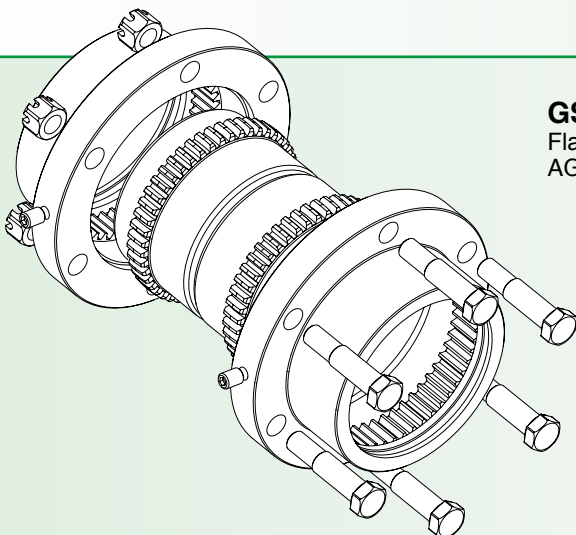

### GST type CF

Flanged type made of 2 semi couplings. Flanges dimensions are according to AGMA standards (type A-B-C). They will fit any AGMA standard half.

## SITEX® ST type “C”

Standard type with 2 hubs and one sleeve. Allows for axial, angular and radial misalignment. Long hub version is also available. Offers compact, powerful design, and easy assembly. Maximum bore in the table is valid for keyway seat DIN 6885/1.

**Note:** It is possible to have aligned keyways upon inquiry.

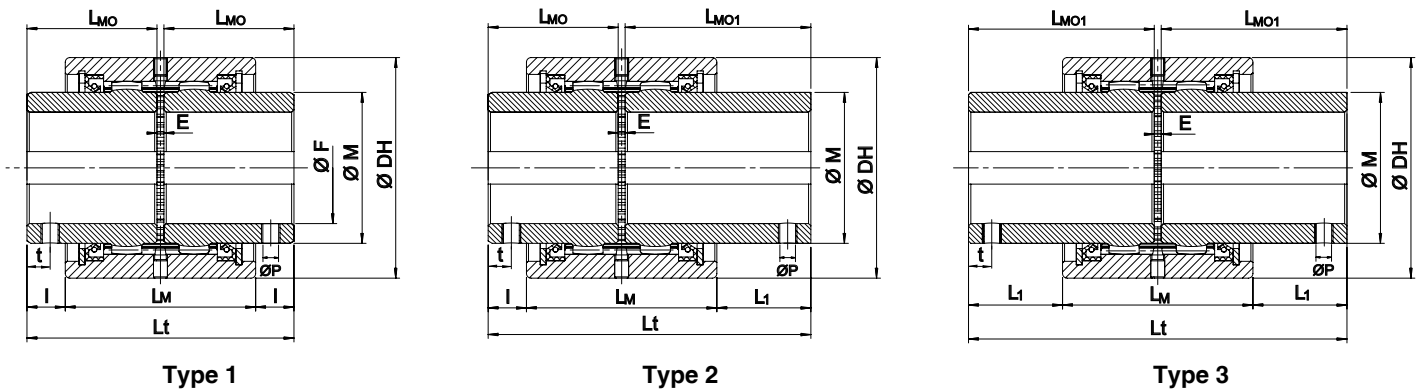

Size	Dimensions [mm]										Technical data									
	DH	E	F <sub>max</sub>	M	L <sub>M</sub>	l	L <sub>mo</sub>	L <sub>1</sub>	L <sub>MO1</sub>	L <sub>t</sub>			Torque [Nm]		n <sub>max</sub> [rpm]	ΔK <sub>a</sub> [mm]	ΔK <sub>r</sub> [mm]	ΔK <sub>w</sub> * [°]	Coupling**	
										Type 1	Type 2	Type 3	T <sub>KN</sub>	T <sub>Kmax</sub>					Moment of inertia x10 <sup>-4</sup> kg · m <sup>2</sup>	W [kg]
28	70	3	28	40	61	12	41	31	60	85	104	123	600	1200	7700	-/+ 1	0,13	0,13	9,8	1,4
38	85	3	38	55	65	17,5	48,5	49	80	100	131,5	163	850	1700	5800	-/+ 1	0,13	0,13	22,7	2,2
48	95	3	48	65	82	16,5	56	40,5	80	115	139	163	1300	2600	5100	-/+ 1	0,22	0,22	43	3,1
62	120	4	62	85	90	25	68	57	100	140	172	204	2200	4400	4000	-/+ 1	0,22	0,22	124	5,7
82	145	4	82	110	96	28,5	74,5	73,5	119,5	153	198	243	3800	7600	3200	-/+ 1	0,24	0,24	285	8,8
98	175	5	98	130	113	28,5	82,5	86,0	140	170	227,5	285	7000	14000	2750	-/+ 1	0,39	0,39	693	14,6
110	198	6	110	150	130	43	105	112,5	174,5	216	285,5	355	10000	20000	2300	-/+ 1	0,48	0,48	1327	23,3
133	230	8	133	180	175	56,5	140	124	207,5	288	355,5	423	15000	30000	2000	-/+ 1	0,79	0,79	3260	39,7
155	270	10	155	210	214	58	160	123	225	330	395	460	24000	48000	1650	-/+ 1	1,05	1,05	7606	66,5
170	300	10	170	230	240	65	180	130	245	370	435	500	34000	68000	1550	-/+ 1	1,31	1,31	13235	94

\* = maximum static misalignment for a correct mounting

\*\* = considering maximum bore

### Setscrews type

Bore size [mm]	Ø P [mm]	t [mm]
up to 38	M8	14
> 38 - 44	M10	14
> 44 - 50	M12	14
> 50 - 55	M14	14
over 55	M16	14

Note: set screw position 90° from the keyway.

**Hub** GST 082 M F40

SITEX® ST coupling

Size

M: Standard hub - ML: Long hub

Bore diameter [mm]

**Manicotto** GST 082 AD

Coupling SITEX® ST C

Size

AD: standard sleeve

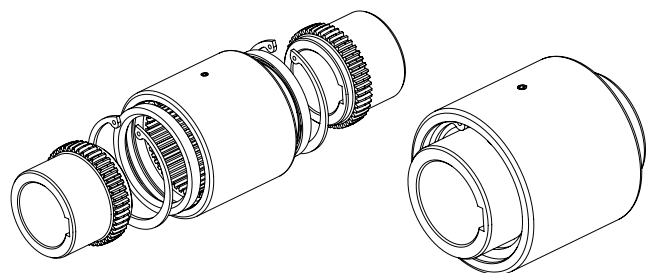

T <sub>KN</sub>	Coupling nominal torque	Nm
T <sub>Kmax</sub>	Coupling maximum torque	Nm
n <sub>max</sub>	Maximum rpm	rpm
ΔK <sub>a</sub>	Maximum axial misalignment	m
ΔK <sub>r</sub>	Maximum radial misalignment	mm
ΔK <sub>w</sub>	Maximum angular misalignment	°
W	Weight	Kg

# SITEX® ST type “CV”

Standard type made of a single hub and one sleeve. It is also available in long hub execution. Offers an economical solution in applications without radial misalignment.

**Nota:** è possibile avere le cave in fase su richiesta.

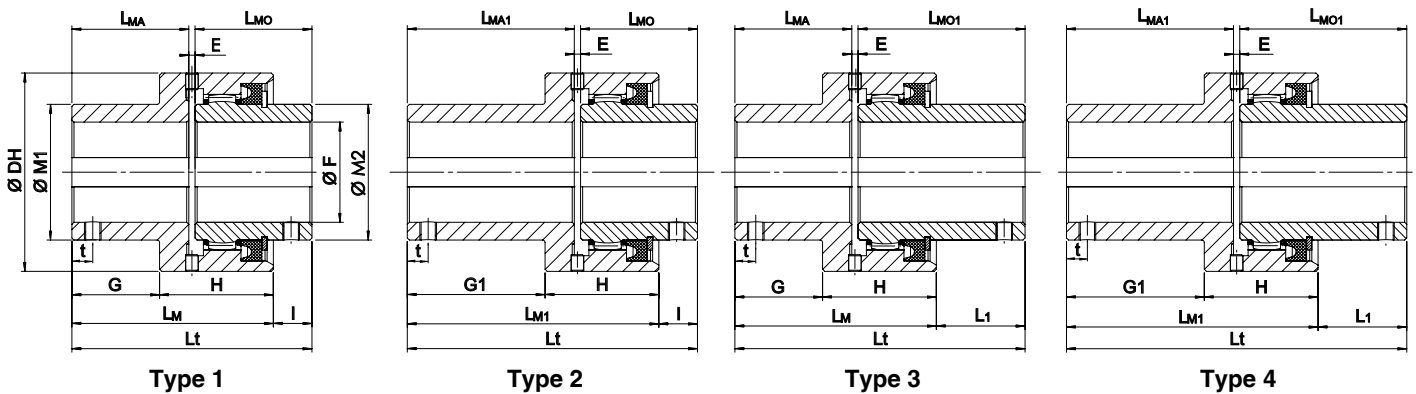

Size	Dimensions [mm]														Technical data								
	DH	E	F <sub>max</sub>	H	M1	M2	I	L <sub>MO</sub>	L <sub>1</sub>	L <sub>MO1</sub>	G	L <sub>MA</sub>	G1	L <sub>MA1</sub>	t	Torque [Nm]		n <sub>max</sub>	ΔKa	ΔKr	ΔKw*	Coupling**	
																T <sub>KN</sub>	T <sub>Kmax</sub>	[rpm]	[mm]	[mm]	[°]	Moment of inertia x10 <sup>-4</sup> kg · m <sup>2</sup>	W [kg]
28	70	3	28	43	42	40	13	41	32	60	29	41	48	60	14	600	1200	7700	-/+ 5	0,13	1°	7,1	1,1
38	85	3	38	49	55	55	16	48,5	47,5	80	35	48,5	66,5	80	14	850	1700	5800	-/+ 5	0,13	1°	17,9	1,9
48	95	3	48	54,5	65	65	18,5	56	42,5	80	42	56	66	80	14	1300	2600	5100	-/+ 5	0,22	1°	31,5	2,5
62	120	4	62	60	85	85	27	68	59	100	45	60	85	100	14	2200	4400	4000	-/+ 5	0,22	1°	95	4,7
82	145	4	82	63	110	110	31	74,5	76	119,5	46	61,5	104	119,5	14	3800	7600	3200	-/+ 5	0,24	1°	212	6,9
98	175	5	98	76	130	130	26	82,5	83,5	140	51	65,5	123,5	138	14	7000	14000	2750	-/+ 5	0,39	1°	511	11,2
110	198	6	110	92	150	150	38	105	107,5	174,5	71	90	143	162	14	10000	20000	2300	-/+ 5	0,48	1°	1080	19

\* = maximum static misalignment for a correct mounting

\*\* = considering maximum bore

**Hub** GSTV 082 M F40

SITEX® ST coupling

Size

M: Standard hub - ML: Long hub

Bore diameter [mm]

**Hub** GSTV 082 AD F40

SITEX® ST CV coupling

Size

AD: std hub-sleeve  
ADL: long hub-sleeve

Bore diameter [mm]

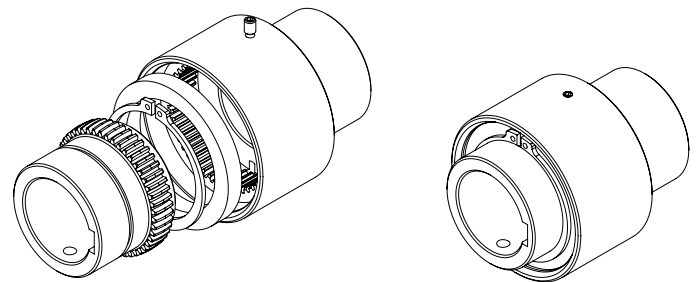

T <sub>KN</sub>	Coupling nominal torque	Nm
T <sub>Kmax</sub>	Coupling maximum torque	Nm
n <sub>max</sub>	Maximum rpm	rpm
ΔK <sub>a</sub>	Maximum axial misalignment	m
ΔK <sub>r</sub>	Maximum radial misalignment	mm
ΔK <sub>w</sub>	Maximum angular misalignment	°
W	Weight	Kg

Heavy-duty applications - SITEX® ST

# SITEX® ST type “CF” A-B-C (AGMA)

STCF A-B-C range conforms to AGMA specifications with regard to flange dimensions, type, and positions of the screws. They are interchangeable with any AGMA coupling half. **Note:** It is possible to have aligned keyways upon inquiry.

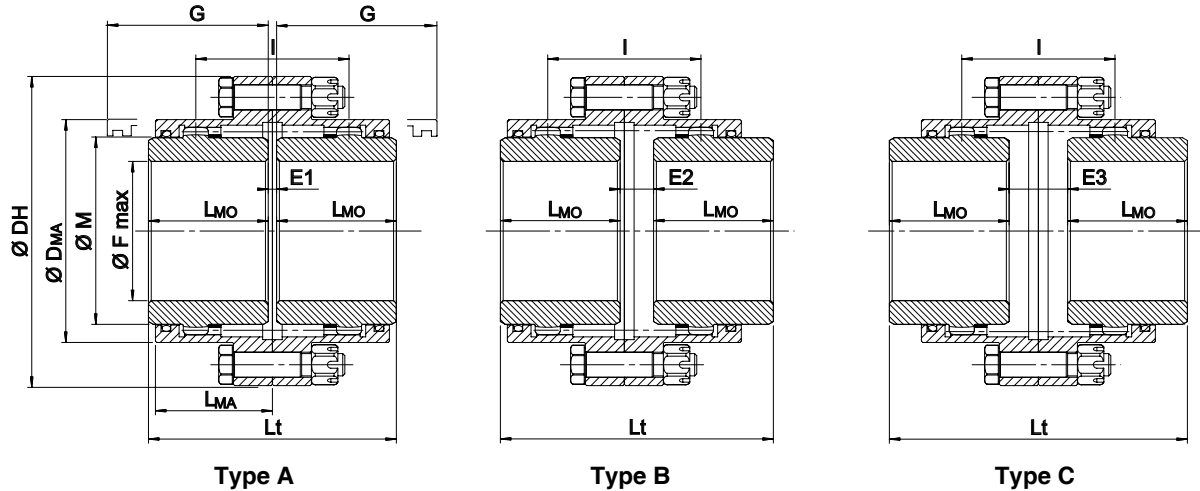

Size	Dimensions [mm]											Technical data															
	F <sub>max</sub>	DH	DMA	M	L <sub>MO</sub>	L <sub>MA</sub>	G*	No. Screw	Screw type	M <sub>s</sub> [Nm]	Type A			Type B			Type C			Torque [Nm]		n <sub>max</sub> [rpm]	ΔKa [mm]	ΔKr [mm]	ΔKw* [°]	Type A**	
											I	L <sub>t</sub>	E <sub>1</sub>	L	L <sub>t</sub>	E <sub>2</sub>	I	L <sub>t</sub>	E <sub>3</sub>	T <sub>KN</sub>	T <sub>Kmax</sub>					Moment of inertia x10 <sup>-4</sup> kg · m <sup>2</sup>	W [kg]
48	48	117	83	65	43	42	74	6	M5	8,5	55	89	3	55	98	12	55	107	21	1300	2600	5100	-/+ 1	2 x 0,5°	0,48	53	3,1
62	62	152	107	85	50	48	84	8	M8	35	59	103	3	59	109	9	59	115	15	2200	4400	4000	-/+ 1	2 x 0,5°	0,51	193	6,6
82	82	178	129,5	110	62	59	104	6	M10	69	79	127	3	79	141	17	79	155	31	3800	7600	3200	-/+ 1	2 x 0,5°	0,69	423	10,6
98	98	213	156	130	76	69	123	6	M12	120	93	157	5	93	169	17	93	181	29	7000	14000	2750	-/+ 1	2 x 0,5°	0,81	1009	17,5
110	110	240	181	150	90	82	148	8	M12	120	109	185	5	109	199	19	109	213	33	10000	20000	2300	-/+ 1	2 x 0,5°	0,95	1822	25,3
133	133	280	211	180	105	98	172	8	M16	295	128	216	6	128	233	23	128	250	40	15000	30000	2000	-/+ 1	2 x 0,5°	1,12	4257	42,5
155	155	318	249,5	210	120	107	192	8	M16	295	144	246	6	144	264	24	144	282	42	24000	48000	1650	-/+ 1	2 x 0,5°	1,26	7920	61,4
170	170	347	274	230	135	120	216	10	M16	295	164	278	8	164	299	29	164	320	50	34000	68000	1550	-/+ 1	2 x 0,5°	1,43	11132	75,6

\* = required space to align the coupling or replace the sealing ring  
 \*\* = considering maximum bore  
 Maximum static misalignment for a correct mounting ΔKw = 2 x 1°  
**Floating shaft designs and special executions are available upon request**

**Hubs (2 pcs for coupling)**      GST    F    082    M    F40

SITEX® ST coupling \_\_\_\_\_

CF execution \_\_\_\_\_

Size \_\_\_\_\_

Hub \_\_\_\_\_

Bore diameter [mm] \_\_\_\_\_

**Flanges (2 pcs for coupling)**      GST    F    082    AD

SITEX® ST coupling \_\_\_\_\_

CF execution \_\_\_\_\_

Size \_\_\_\_\_

Flange \_\_\_\_\_

**Set of screw (1 kit for coupling)**      GST    F    082    KIT

SITEX® ST coupling \_\_\_\_\_

CF execution \_\_\_\_\_

Size \_\_\_\_\_

Set of screws \_\_\_\_\_

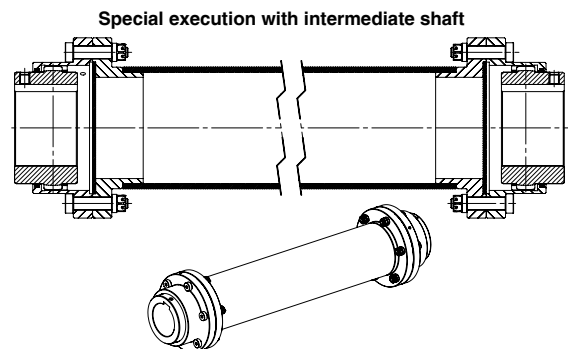
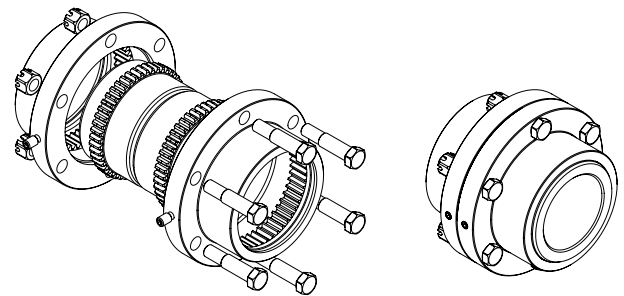

M <sub>s</sub>	Screw tightening torque	Nm
T <sub>KN</sub>	Coupling nominal torque	Nm
T <sub>Kmax</sub>	Coupling maximum torque	Nm
n <sub>max</sub>	Maximum rpm	rpm
ΔKa	Maximum axial misalignment	m
ΔKr	Maximum radial misalignment	mm
ΔKw	Maximum angular misalignment	°
W	Weight	Kg

# SITEX® ST type “CF” D-E-F

Double-cardanic crowned gear coupling. Allows for axial, angular, and radial shaft misalignment.  
**Note:** It is possible to have aligned keyways upon inquiry.

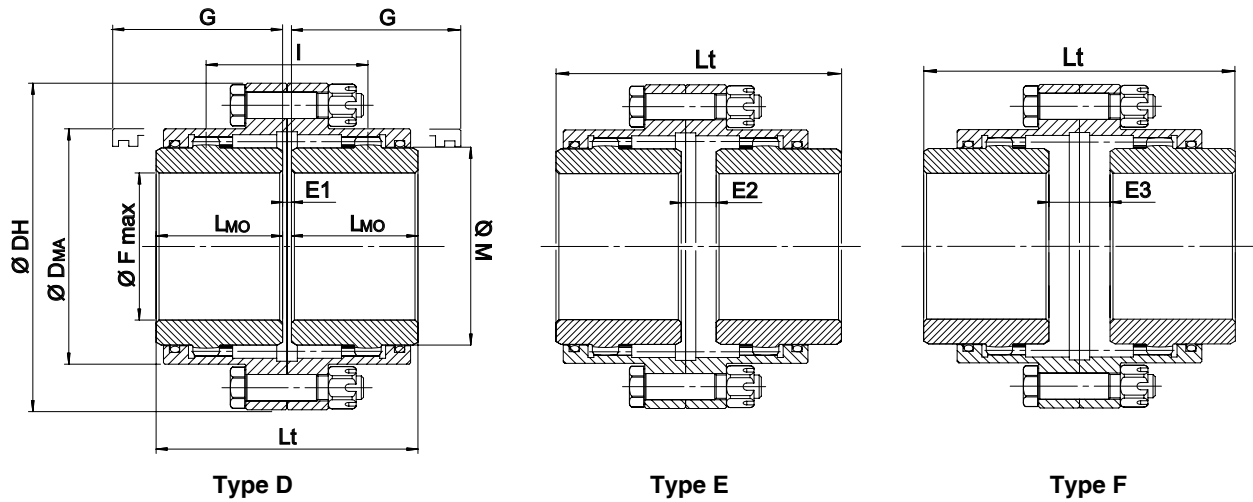

Size	Dimensions [mm]										Technical data													
	F <sub>min</sub>	F <sub>max</sub>	DH	D <sub>MA</sub>	M	L <sub>MO</sub>	G*	No. Screw	Screw type	M <sub>s</sub> [Nm]	Type D		Type E		Type F		Torque [Nm]		n <sub>max</sub> [rpm]	ΔKa [mm]	ΔKr [mm]	ΔKw* [°]	Moment of inertia** x10 <sup>-4</sup> kg · m <sup>2</sup>	**W [kg]
	L <sub>t</sub>	E <sub>1</sub>	L <sub>t</sub>	E <sub>2</sub>	L <sub>t</sub>	E <sub>3</sub>	T <sub>KN</sub>	T <sub>Kmax</sub>																
50	12	50	111	82,5	69	43	58	6	M8	26	89	3	91	5	93	7	1800	4200	6000	-/+ 1	0,25	2 x 0,5°	50	4
60	18	60	142	104,5	85	50	68	8	M10	52	103	3	108	8	113	13	2700	6400	4620	-/+ 1	0,25	2 x 0,5°	120	8
75	28	75	168	130,5	107	62	87	10	M10	52	127	3	138	14	149	25	5500	13000	4140	-/+ 1	0,25	2 x 0,5°	320	13
95	40	95	200	158,5	133	76	95	10	M12	91	157	5	164	12	171	19	8600	21000	4000	-/+ 1	0,25	2 x 0,5°	850	26
110	50	110	225	183,5	152	90	120	12	M12	91	185	5	204	24	223	43	13500	34000	3860	-/+ 1	0,50	2 x 0,5°	1620	37
130	60	130	265	211,5	178	105	130	12	M16	215	216	6	237	27	258	48	22200	54000	3720	-/+ 1	0,50	2 x 0,5°	3760	59
155	70	155	300	245,5	209	120	135	14	M16	215	246	6	272	32	298	58	34200	83000	3190	-/+ 1	0,50	2 x 0,5°	7280	91
170	85	170	330	275	234	135	155	14	M16	215	278	8	307	37	336	66	43500	101000	2900	-/+ 1	0,50	2 x 0,5°	12260	123
190	95	190	370	307	254	150	195	14	M18	310	308	8	350	50	392	92	69200	156000	2570	-/+ 1	0,50	2 x 0,5°	20990	170
210	110	210	406	335	279	175	220	14	M22	575	358	8	403	53	448	98	82500	196000	2330	-/+ 1	0,90	2 x 0,5°	34010	234
230	120	230	438	367	305	190	236	14	M22	575	388	8	438	58	488	108	150500	349000	2150	-/+ 1	0,90	2 x 0,5°	50520	295
280	130	280	505	423	355	220	273	16	M24	735	450	10	512	72	574	134	198200	480000	1800	-/+ 1	0,90	2 x 0,5°	103200	455
325	150	325	580	475	400	250					512	12	-	-	-	-	275000	551000	1200	-/+ 1	1,00	2 x 0,5°	206000	685
370	170	370	630	520	450	275					562	12	-	-	-	-	381000	762000	980	-/+ 1	1,00	2 x 0,5°	335000	920
400	190	400	700	556	490	305					622	12	-	-	-	-	492000	984000	900	-/+ 1	1,00	2 x 0,5°	533000	1210
430	210	430	760	615	550	330					672	12	-	-	-	-	658000	1315000	800	-/+ 1	1,00	2 x 0,5°	835000	1590
475	240	475	825	680	580	355					722	12	-	-	-	-	835000	1669000	700	-/+ 1	1,00	2 x 0,5°	128400	2060

\* = required space to align the coupling or replace the sealing ring  
 \*\* = considering hub without bore  
 Maximum static misalignment for a correct mounting ΔKw = 2 x 1°  
 Seal flange sizes from 325 to 475

### Special execution with intermediate shaft

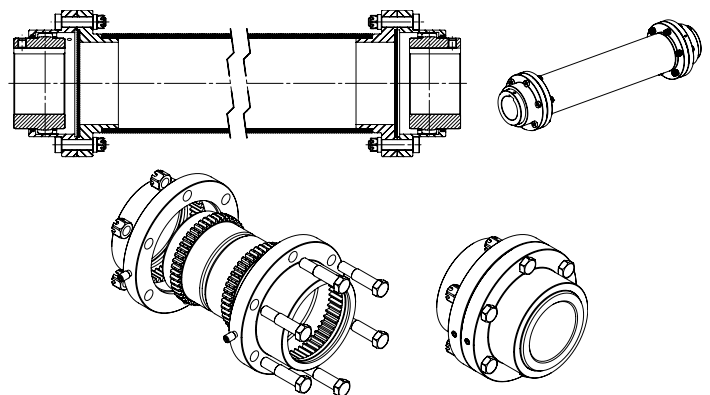

Coupling	GST	FD	75	F40	L	F50
SITEX® ST coupling						
CF execution type D						
Size						
F...: hub bore 1 end execution [mm]						
L: long hub						
F...: hub bore 2 end execution [mm]						

M <sub>s</sub>	Screw tightening torque	Nm
T <sub>KN</sub>	Coupling nominal torque	Nm
T <sub>Kmax</sub>	Coupling maximum torque	Nm
n <sub>max</sub>	Maximum rpm	rpm
ΔK <sub>a</sub>	Maximum axial misalignment	m
ΔK <sub>r</sub>	Maximum radial misalignment	mm
ΔK <sub>w</sub>	Maximum angular misalignment	°
W	Weight	Kg

## Technical data for SITEX® ST coupling selection

- 1) Select the coupling according to the largest shaft diameter
- 2) Calculate the nominal torque  $T_N$  to be transmitted:

$$T_N = \frac{9550 \cdot P}{n} \quad [\text{Nm}]$$

With  $P$  = nominal power installed (kW),  $n$  = rpm in the drive (1/min)

- 3) Select the correct service factors  $k_1$  and  $k_2$
- 4) Verify the nominal torque of the coupling is greater than the corrected machine nominal torque:

$$T_{KN} \geq T_N \cdot \frac{k_1}{k_2} \cdot S_\theta \cdot S_D$$

With  $k_1$  application service factor and  $k_2$  angular misalignment (for hub) service factor

$S_\theta$  = Coefficiente di temperatura

T (°C)	-10 °C / +80 °C
$S_\theta$	1

$S_D$  = Fattore di servizio

Moto unidirezionale	1
Moto alternato	1,7

Coefficiente di frequenza degli avviamenti

S/h	< 10	< 25	< 50
$S_Z$	1	1,2	1,4

- 5) Verify that the starting torque is less than the maximum torque transmissible by the coupling

$$T_{Kmax} \geq (T_S + T_N) \cdot S_Z \cdot S_\theta \cdot S_D$$

$T_S$  torque spike or peak [N · m]  
 $T_N$  can be omitted if absent

- 6) Verify the maximum misalignments are respected.
- 7) Verify the hub shaft connection could bear the transmission peak torque. If necessary change the hub shaft connection type.
- 8) Verify the maximum rpm of the coupling is respected.

### Application service factor $k_1$

LOAD TYPE	TYPE OF SERVICE	APPLICATION DRIVEN MACHINE	DRIVER MACHINE		
			Electric motors or turbines	Hydraulic motors, gears drivers	Reciprocating engine Electric motors frequent starts
<b>LIGHT peak torque</b>	Continuous duty with light overloads and shocks for a short time and not frequent	Multistage centrifugal blowers, Steel wire machine Reciprocating pumps, Large fans Agitators (liquids) Machine tools main drive Conveyor and elevators not uniform loaded	1,4	1,75	2
<b>MEDIUM peak torque</b>	Intermittent duty with frequent light shocks, medium overloads (short time)	Reciprocating compressors and pumps Cranes, Agitators (solids) Hoisting equipment, Calenders for rubber or plastic Winding machine (paper industry)	1,75	2	2,5
<b>HEAVY peak torque</b>	Duty with very high and frequent shocks, frequent load reversal	Laundry machines, Mixers for rubber and plastic Road and rail machines/equipment, Cranes (heavy duty) Pulp grinders and refiners, paper presses Marine drives, mine fans, Wire drawing, Metal mills drives Heavy duty drives in steel mills, Hammer mills, rubber and plastic mills Stone crushers	2	2,5	3

### $k_2$ service factor for angular misalignment

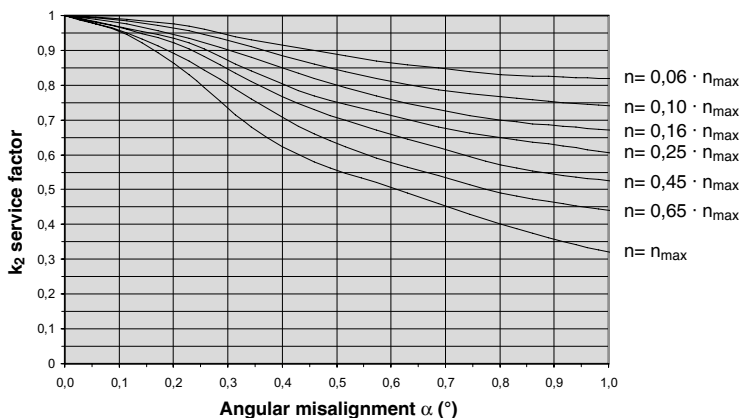

## Installation and maintenance

Good alignment of the shafts help to reduce reaction forces on shafts and bearing and is important for the coupling life.

In case the hubs are machined by the user in order to adapt them to the machine, it is user responsibility:

- to control all parameters regarding balancing, bore concentricity and any other parameter which may affect coupling life and a safe transmission, are respected.
- to verify the hub length and corresponding keyway seat are compatible with the necessary torque transmission considering the peak loads. Maximum bore diameters allowed in hubs as described in dimensional tables.
- to verify the hub material is adequate for the clamping system.

During compensation of misalignments, axial forces are generated. These forces must be considered when sizing machine bearing. For a calculation, please consult our technical office. It is also recommended that hubs are axially secured in order to avoid axial forces on the seals which may cause lubricant leakage and, therefore, shorter coupling life. It is recommended to secure the set screw with Loctite, use an end plate, or interference fit.

### Warning

Gear couplings are rotating parts and potentially dangerous. It is recommended to protect the rotating parts and comply with existing safety regulations in order to keep personnel and equipment safe.

### Mounting

SITEX® ST couplings must stored in a non-corrosive environment prior to installation.

In case of environment with high humidity it is the user's, responsibility to protect the couplings, or to ask for a special surface treatment. Prior to starting the mounting operation, it is recommended to:

- verify there are no missing or damaged components
  - have the necessary mounting instructions and tools required for mounting and shaft alignment.
  - make sure the machine is shut down and there is no risk of accidental start up
  - be careful in handling the coupling components. Particular care should be taken with the geared crown
- 1) Check all components to be assembled are clean.
  - 2) Position one snap ring and one seal on every shaft.
  - 3) Position the hubs on the respective shafts. If necessary in order to facilitate the mounting operation, it is possible to heat the hubs (max. 120 °C). In such cases avoid contact between hub and seal until room temperature is reached. For a safe mounting hub must be positioned flush with the shaft. Mount the set screws and tighten properly. In order to avoid accidental screws loosening due to vibration, use some Loctite glue.
  - 4) Mount the sleeve on the longer shaft.
  - 5) Position the units to be connected respecting the dimension "E" between the shafts.
  - 6) Align the 2 shafts being careful that the catalogue values are respected. It is possible to use the SIT LINE-LASER® to facilitate the operation.
  - 7) Couplings are delivered without lubricant. Lightly grease the geared parts of hubs and sleeve. Lightly lubricate the seal and position them on the respective hubs.
  - 8) Position the sleeve on the hubs. Insert the seals and the snap rings on the proper groove.
  - 9) Remove the grease nipple and properly fill the chamber with grease. For the CF type, repeat the operation on the second half coupling. Position the grease nipple and tighten properly. Inspect and maintain.

It is recommended to make a regular inspection which may detect abnormal noise, vibration, or leakage.

Every 5.000 hours, or once a year, remove grease nipples, position the coupling with one nipple at 45° with respect to the rotation axis, force grease from the bottom hole until clean grease flows. Reinsert the nipples and tighten properly.

Every 10.000 hours or every 2 years, remove snap rings and seals, clean and inspect seals and geared parts, verify alignments and mount the coupling. Low viscosity oil may be used to clean the coupling from used grease.

### Recommended lubricants

Coupling lubrication is important for a long coupling duration.

#### 1. Standard speed and load

Agip GR MV/EP 1  
Amoco coupling grease  
API: API grease PGX-0  
Caltex Coupling Grease  
Castrol Impervia MDX  
Chevron Polyurea grease EP0

Esso Fibrax 370  
Fina Marson EPL 1  
Kübler Klüberplex GE 11-680  
IP: ATHESIA-EPO  
Mobil Mobilux EP0, Mobilgrease XTC  
Q8 Rembrandt EP0

Shell Gadus S2 V220  
Texaco Coupling Grease  
Total Specis EPG  
Tribol 3020/1000-1  
Unirex RS 460, Pen-0- Led EP

#### 2. High speed (> 50 m/s), high loads

Caltex Coupling Grease  
Klüber Klüberplex GE 11-680  
Mobil Mobilgrease XTC  
Shell Albida GC1