

Drawn Cup Roller Clutches

NSK drawn cup roller clutches are high-performance products that enable users to make the ideal choice from among a wide selection for meeting the needs of various applications.



Drawn cup roller clutches featuring easy installation and high performance in a compact design.



1. Compact and lightweight

Unique structure of the drawn cup outer ring makes the clutch compact and lightweight.

2. Accurate action

Accurate performance and low friction torque during overrun.

3. Superior durability

High torque capacity and superior durability; same cross-section height as standard drawn cup needle bearings.

4. Easy to mount

Installation is easily accomplished with a simple press fit in the housing.

Selecting type of drawn cup roller clutch

NSK drawn cup roller clutches are one-way clutches that have the unique structure of a drawn cup outer ring and are extremely compact. The clutches offer accurate performance, low frictional torque for overrun, and are easy to install. NSK has a broad product lineup, including drawn cup roller clutches for high torque loads, plastic housing, and integrated units. The bearings have a solid reputation built over the years for their durability and reliability.

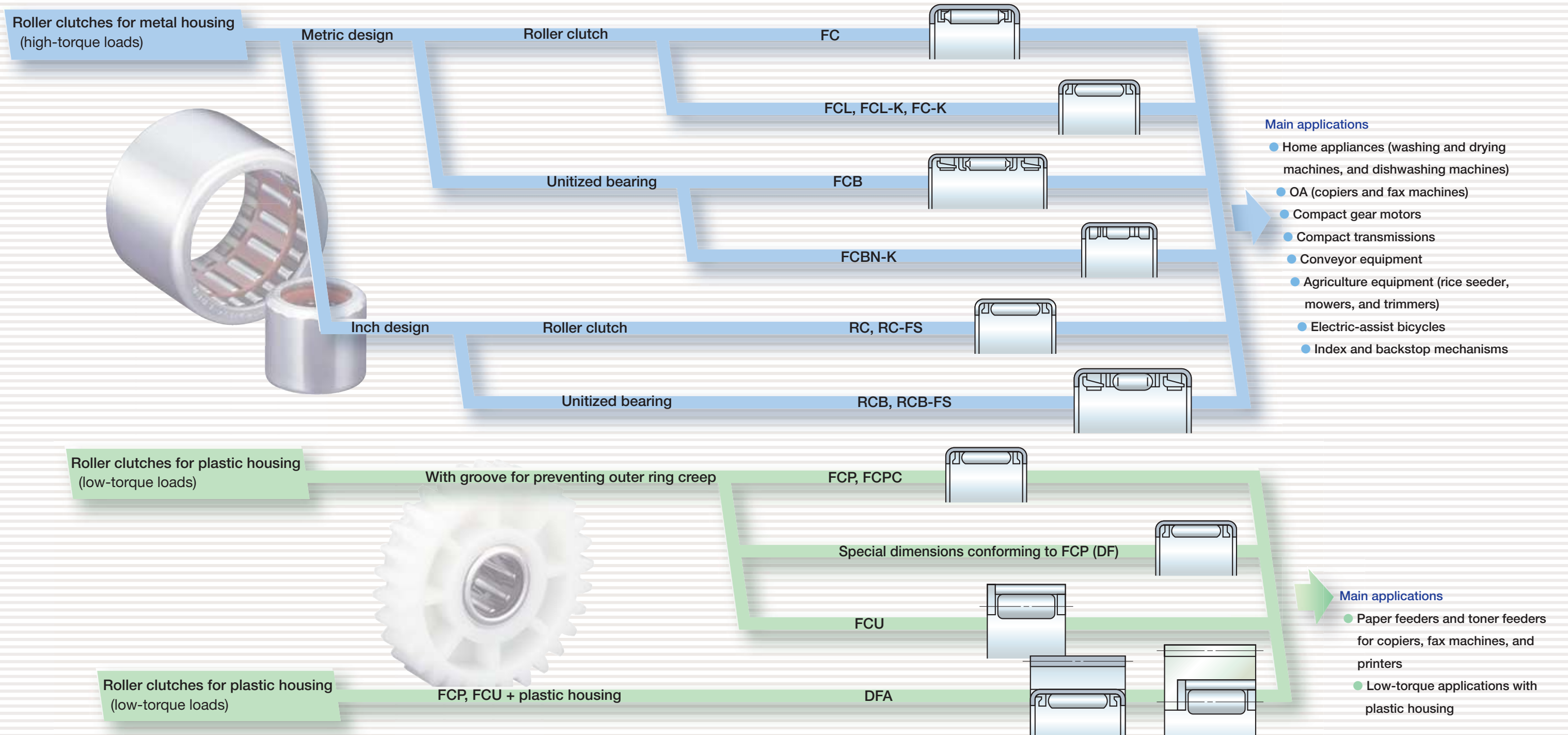

● **Customized roller clutch for special applications**

In addition to the roller clutches that appear in this catalog, custom roller clutches can be designed and manufactured for special applications. Contact NSK for details.

FC·FCL·FCB·FCBN (Metric)
RC·RCB (Inch)

Design and types

Drawn cup roller clutches for metal housing consist of an outer ring, which forms a cam face on a bore surface by precision deep drawing, rollers, a cage, and spring. Table 1 gives the types of drawn cup roller clutches, and Figs. 1 and 2 show the states of engagement and overrun.



Table 1 Types of Drawn Cup Roller Clutches

Type	Code	Description
Metric	FC	For torque transmissions only; contains stainless steel spring
	FCL	For torque transmissions only; contains stainless steel spring
	FCB	For torque transmissions and bearing radial load; containing stainless steel spring
	FCBN	Narrow type; for torque transmissions and bearing radial load; contains stainless steel spring
Inch	RC	For torque transmissions only; contains plastic spring
	RCB	For torque transmissions and bearing radial load; containing plastic spring
	RC-FS	For torque transmissions only; contains stainless steel spring
	RCB-FS	For torque transmissions and bearing radial load; containing stainless steel spring

Remarks The standard structure for metric drawn cup roller clutches is a spring pushing multiple rollers. The K type consists of a spring pressing a single roller for low torque. (K is included at the end of the bearing number.)

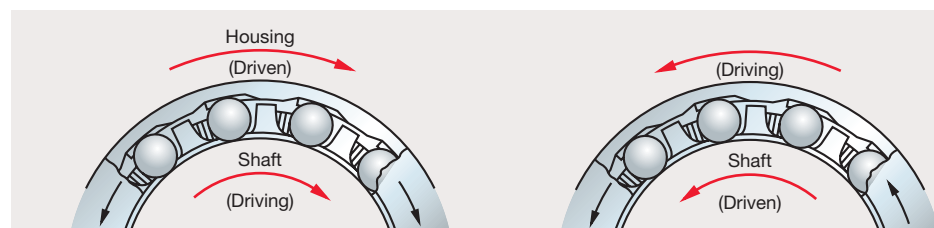

Fig. 1 When Clutch is Engaged

With the force of the spring mounted inside the clutch, which is produced by the relative rotation of the clutch and the shaft mounted to the housing, the roller contacts the wedge face and engages it. The engagement directions are opposite depending on whether the shaft or housing is driven.

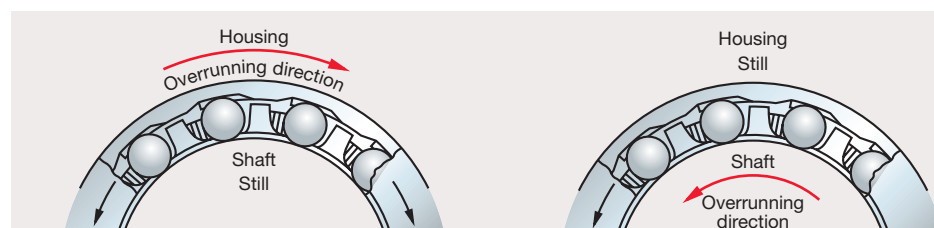

Fig. 2 When Clutch is Overrun

By the relative rotation of the clutch and the shaft mounted to the housing, the roller operates free from the wedge face and overruns. In this case, the housing and the clutch overrun in the clockwise direction and the shaft overruns in the counterclockwise direction.

Specifications of shaft and housing

Drawn cup roller clutches do not usually use an inner ring, but rather use the shaft as a raceway ring. Made of thin steel plate, they perform best only with press fitting into normal housing. Therefore, the dimensional accuracy and hardness of the shaft and housing are required to satisfy the specification given in Table 2. Fittings of the drawn cup roller clutch for metal housing under ordinary operating conditions are given in Table 3.

Table 2 Accuracy, Roughness, and Hardness

Classification	Shaft	Housing bore
Out-of-roundness tolerance	IT3 2	IT4 ~ IT5 2 2
Cylindrical tolerance	IT3 2	IT4 ~ IT5 2 2
Roughness, R_a	0.4	1.6
Hardness	HRC58-64 Requires layer hardening to proper depth.	—

Table 3 Fittings for Drawn Cup Roller Clutches

Type	Code	Fitting tolerance	
		Shaft	Housing bore
Metric	FC, FCL, FCB, FCBN	h6	N7
Inch	RC (FS), RCB (FS)	h6	J7

Mounting

For press fitting of drawn cup roller clutches into the housing bore, it is necessary to prevent the outer ring from deformation and damage by using an appropriate jig as shown in Fig. 4.

Precautions for mounting are described below:

- 1) Use a hand press or similar tool for press fitting. Avoid fitting by striking with a hammer.

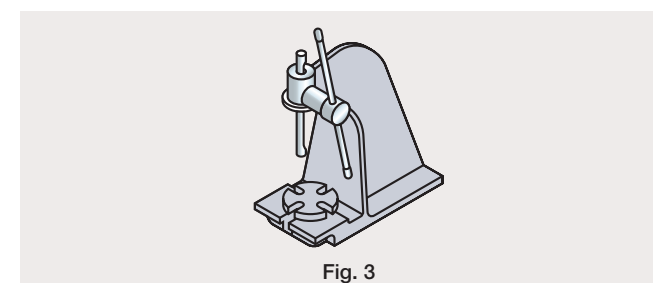

Fig. 3

- 2) Place the roller clutch side face on the marked side onto the jig shoulder. For accurate press fitting, provide a stopper for the locations and guide.

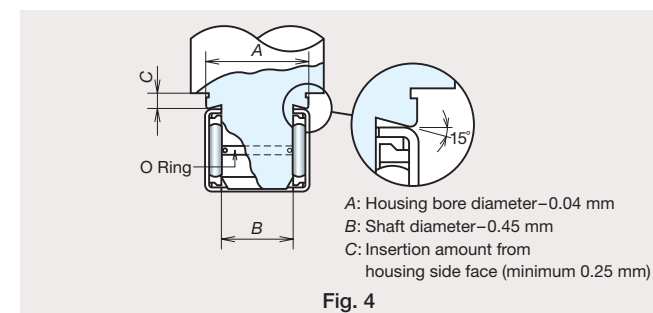

Fig. 4

Operating temperature and engagement speed

The operating temperature of drawn cup roller clutches should be 90 °C or less for a standard plastic spring and 120 °C or less for a stainless steel spring. When engagement speed exceeds 200 cycles per minute and when operation of the spring is impaired by low temperatures, a clutch with a stainless steel spring must be used.



Lubrication

Oil lubrication is generally recommended, and under the conditions described below, it is required.

- Overrunning
- High engagement speed
- Very low transmitting torque
- High operating temperature

As grease lubrication is common, NSK produces bearings packed with standard grease.

- 3) A snap ring and shoulder for positioning the roller clutch are not required. When press fitting the roller clutch into the housing with a shoulder or a closed end, care should be taken not to have the side face of the roller clutch contact the shoulder or bottom.

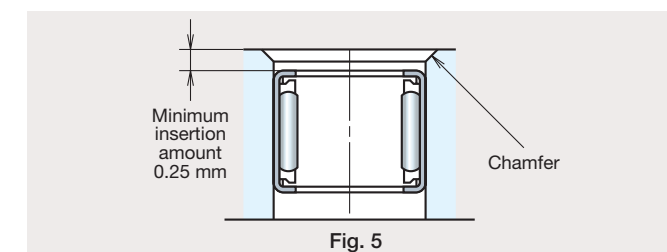

Fig. 5

- 4) When assembling the shaft, keep rotating it while mounting. A large chamfer for the corner of the shaft is advisable.

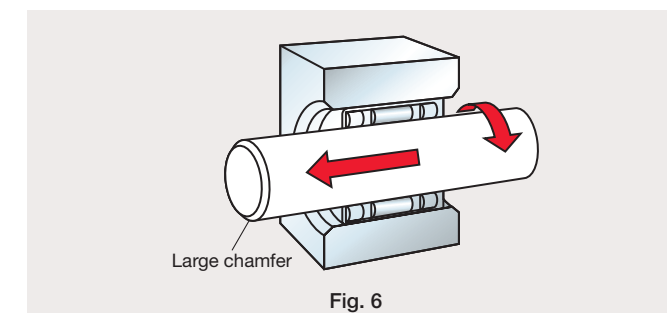

Fig. 6

Engagement direction

Clutch engagement takes place when rotating the housing in the direction of the arrow (←LOCK) marked on the side face of the drawn cup outer ring.

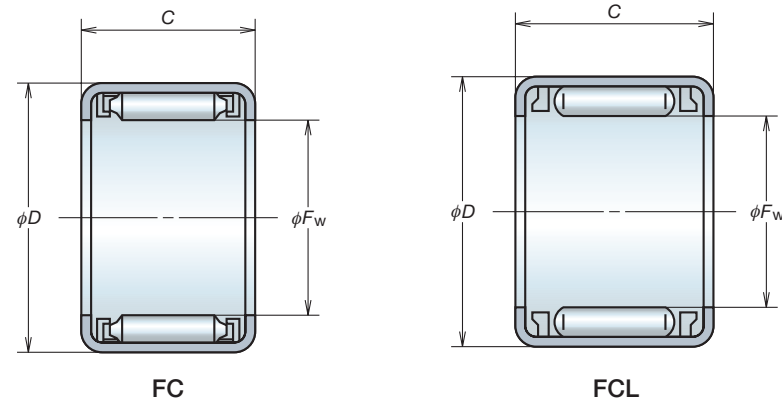

Fig. 7

Grease containing extreme pressure additives should be avoided as it may cause slippage. Hardening of grease due to deterioration and formation of sludge impair the lock performance of the clutch. Extreme caution must be taken to prevent deterioration of lubricant.

It is extremely essential to monitor for any deterioration of lubricant. If replenishment is required, please contact NSK to select the proper lubricant.

FC·FCL (Metric)



FCB·FCBN (Metric)

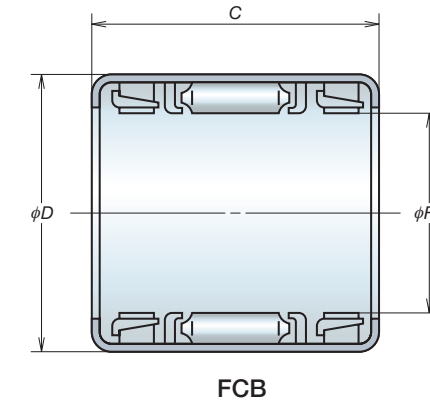

Roller Clutch Numbers	Boundary Dimensions (mm)			Torque Capacities (N · m)	Mass (g) approx.	Minimum Outside Diameters of Housing (mm)	Matching Support Needle Roller Bearing Numbers	
	F_w	D	$C_{-0.25}^0$				Full Complement	With Cage
FC-4K ⁽¹⁾	4	8	6	0.31	0.90	12	F-48	—
FC-6	6	10	12	2.45	4.1	14	F-68	FJ-69
FC-6K ⁽¹⁾	6	10	12	1.96	2.7	14	F-68	FJ-69
FCL-8K ⁽¹⁾	8	12	12	3.24	3.3	18	F-810	FJ-810
FC-8	8	14	12	4.02	6.8	20	FH-810	FJH-810
FCL-10K ⁽¹⁾	10	14	12	4.41	3.9	23	F-1010	FJ-1010
FC-10	10	16	12	5.30	9.1	25	FH-1010	FJH-1010
FC-12	12	18	16	13.24	12	27	FH-1212	FJH-1212
FC-14K ⁽¹⁾	14	20	16	14.22	16	29	F-1412	FJ-1412
FC-16	16	22	16	20.59	18	31	F-1612	FJ-1612
FC-20	20	26	16	30.89	21	38	F-2012	FJ-2012
FC-20K ⁽¹⁾	20	26	16	29.42	16	38	F-2012	FJ-2012
FC-25	25	32	20	68.65	34	46	F-2516	FJ-2516
FC-25K ⁽¹⁾	25	32	20	65.70	26	46	F-2516	FJ-2516
FC-30	30	37	20	95.12	42	51	F-3020	FJ-3020

Note ⁽¹⁾ Bearing numbers ending in K have a lock function and offer higher reliability.
Remarks Be sure to check if the product is in stock. Consult NSK when selecting.

Roller Clutch Numbers	Boundary Dimensions (mm)			Torque Capacities (N · m)	Mass (g) approx.	Minimum Outside Diameters of Housing (mm)	Basic Load Ratings (N) C_r	Limiting Loads (N) P_{max}
	F_w	D	$C_{-0.25}^0$					
FCBN-4K ⁽¹⁾	4	10	9	0.19	2.7	16	1 190	540
FCBN-6K ⁽¹⁾	6	12	10	0.56	3.8	18	1 630	735
FCB-8	8	14	20	4.02	11	20	2 430	1 200
FCB-10	10	16	20	5.30	13	25	2 820	1 450
FCB-12	12	18	26	13.24	18	27	3 800	2 240
FCB-16	16	22	26	20.59	24	31	4 100	2 670
FCB-20	20	26	26	30.89	28	38	5 100	3 550
FCB-25	25	32	30	68.65	48	46	6 850	4 700
FCB-30	30	37	30	95.12	54	51	7 000	5 250

Note ⁽¹⁾ Bearing numbers ending in K have a lock function and offer higher reliability.
Remarks Be sure to check if the product is in stock. Consult NSK when selecting.

RC (Inch)

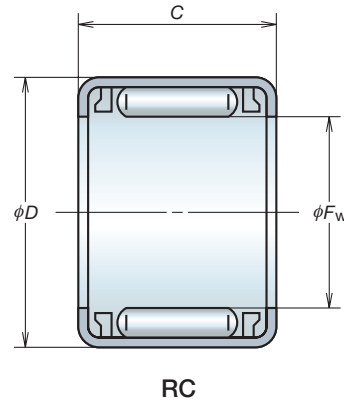

RCB (Inch)

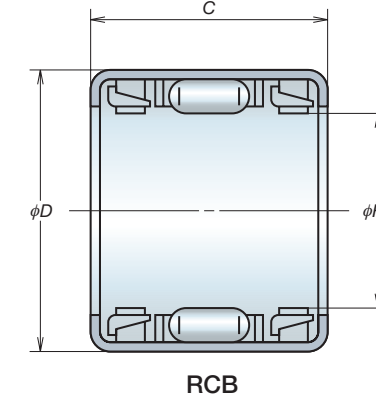

Roller Clutch Numbers	Boundary Dimensions (mm, inch)						Torque Capacities (N · m)	Mass (g) approx.	Minimum Outside Diameters of Housing (mm)	Matching Support Needle Roller Bearing Numbers	
	F_w	D	$C_{-0.25}^0$	F_w	D	$C_{-0.25}^0$				Full Complement	With Cage
RC-040708	6.350	0.2500	11.112	0.4375	12.70	0.5000	1.96	3.6	16	B-45	J-45
RC-040708-FS ⁽¹⁾	6.350	0.2500	11.112	0.4375	12.70	0.5000	1.96	3.6	16	B-45	J-45
RC-061008	9.525	0.3750	15.875	0.6250	12.70	0.5000	5.10	7.7	22	BH-68	JH-68
RC-061008-FS ⁽¹⁾	9.525	0.3750	15.875	0.6250	12.70	0.5000	5.10	7.7	22	BH-68	JH-68
RC-081208	12.700	0.5000	19.050	0.7500	12.70	0.5000	8.34	9.1	28	BH-88	JH-88
RC-081208-FS ⁽¹⁾	12.700	0.5000	19.050	0.7500	12.70	0.5000	8.34	9.1	28	BH-88	JH-88
RC-101410	15.875	0.6250	22.225	0.8750	15.88	0.6250	16.18	14	30	BH-108	JH-108
RC-101410-FS ⁽¹⁾	15.875	0.6250	22.225	0.8750	15.88	0.6250	16.18	14	30	BH-108	JH-108
RC-121610	19.050	0.7500	25.400	1.0000	15.88	0.6250	22.06	15	36	B-1210	J-1210
RC-121610-FS ⁽¹⁾	19.050	0.7500	25.400	1.0000	15.88	0.6250	22.06	15	36	B-1210	J-1210
RC-162110	25.400	1.0000	33.338	1.3125	15.88	0.6250	46.58	26	48	BH-168	JH-1612
RC-162110-FS ⁽¹⁾	25.400	1.0000	33.338	1.3125	15.88	0.6250	46.58	26	48	BH-168	JH-1612

Note (1) Even if the suffix FS is not marked on the product, it can be distinguished from others because its cage is always red.
Remarks Be sure to check if the product is in stock. Consult NSK when selecting.

Roller Clutch Numbers	Boundary Dimensions (mm, inch)						Torque Capacities (N · m)	Mass (g) approx.	Minimum Outside Diameters of Housing (mm)	Basic Load Ratings (N) C_r	Limiting Loads (N) P_{max}
	F_w	D	$C_{-0.25}^0$	F_w	D	$C_{-0.25}^0$					
RCB-061014	9.525	0.3750	15.875	0.6250	22.22	0.8750	5.10	14	22	3 700	2 010
RCB-061014-FS ⁽¹⁾	9.525	0.3750	15.875	0.6250	22.22	0.8750	5.10	14	22	3 700	2 010
RCB-081214	12.700	0.5000	19.050	0.7500	22.22	0.8750	8.34	16	28	4 400	2 580
RCB-081214-FS ⁽¹⁾	12.700	0.5000	19.050	0.7500	22.22	0.8750	8.34	16	28	4 400	2 580
RCB-101416	15.875	0.6250	22.225	0.8750	25.40	1.0000	16.18	23	30	4 900	3 050
RCB-101416-FS ⁽¹⁾	15.875	0.6250	22.225	0.8750	25.40	1.0000	16.18	23	30	4 900	3 050
RCB-121616	19.050	0.7500	25.400	1.0000	25.40	1.0000	22.06	26	36	5 550	3 700
RCB-121616-FS ⁽¹⁾	19.050	0.7500	25.400	1.0000	25.40	1.0000	22.06	26	36	5 550	3 700
RCB-162117	25.400	1.0000	33.338	1.3125	27.00	1.0630	46.58	45	48	9 750	6 750
RCB-162117-FS	25.400	1.0000	33.338	1.3125	27.00	1.0630	46.58	45	48	9 750	6 750

Note (1) Even if the suffix FS is not marked on the product, it can be distinguished from others because its cage is always red.
Remarks Be sure to check if the product is in stock. Consult NSK when selecting.

FCP (Metric)

■ Features

1. Can be easily unitized

The gear, pulley, rollers, etc., can be made into a unit with plastic parts if necessary.

2. Creep prevention mechanism

Creep is reliably prevented by combining a thin roller clutch with a special groove around the outer bore of the outer ring, and by precision pressing of plastic parts.

3. High accuracy, superior durability

The cam face is formed by precision deep drawing, so it offers high precision and superior durability.

4. Compact and lightweight

This series offers a compact size and a lightweight construction.

■ Design

Drawn cup roller clutches for plastic housings consist of a cam face on the inner bore of a precision deep drawn cup, a cup outer ring with a creep prevention groove formed on its outer bore, rollers, and an integrated cage with spring. The integrated housing can be provided with a resin gear, pulley, or roller, so various types can be made according to requirements. The engagement and overrun state of the roller clutch is shown in Figs. 8 and 9.

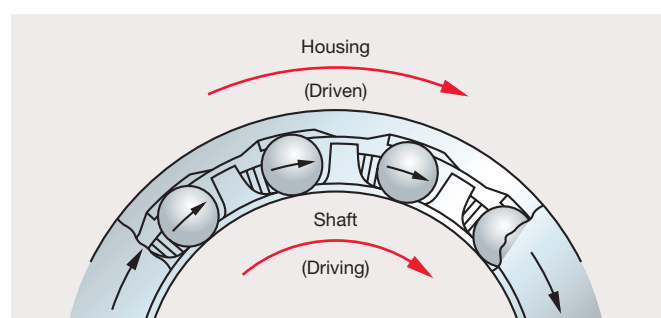

Fig. 8 Clutch Engagement

When the shaft turns to the right, the roller pressed by the action of the cage's spring proceeds to the cam face engagement position, where the entire assembly is turned with the shaft.

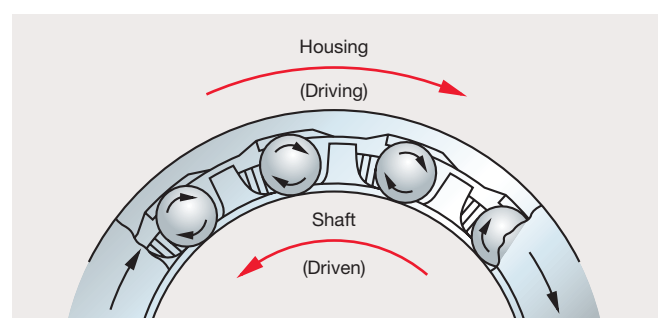

Fig. 9 Clutch Overrun

When the housing turns faster to the right than the shaft, the shaft turns to the left relative to the housing. The rollers instantaneously separate from the cam face.

■ Specifications and fitting of shaft and housing

When drawn cup roller clutches for plastic housings are press-fitted into plastic housings, specifications are for normal dimension and dimensional accuracy.

Shaft specifications are given on the right.

Fitting is basically the same as for drawn cup roller clutches for metal housing, but differs largely according to operating conditions. Contact NSK for details.

Shaft/material: Metal such as S~C, SS~, SUS
Hardness HRC50 or more

Shaft/accuracy: Class h9

Shaft/surface hardness: 0.4 R_a

Housing: Contact NSK for housing shape or inner bore dimensions when using with a clutch. The clutch can also be used with cylindrical steel or aluminum housings. Contact NSK for details concerning fitting, etc.

■ Mounting

When fitting the roller clutch into a plastic housing, the creep prevention groove on the outer bore of the roller clutch must be matched with the phase of the protrusion on the inner bore of the housing.

Other than that, the fitting method and mounting jig are the same as for drawn cup roller clutches for metal housings.

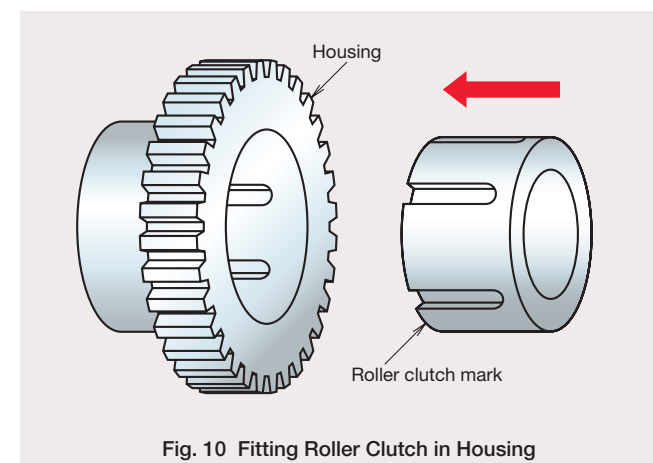

Fig. 10 Fitting Roller Clutch in Housing

■ Operating temperature

The operating temperature range of the roller clutch is -10 °C to 90 °C. Contact NSK if you plan to use the roller clutch outside this range.

■ Lubrication

The roller clutch is sealed with special grease and does not need to be replenished. Take steps to prevent ingress of other types of grease or foreign matter during operation.

■ Life

With the torque capacity given in the dimensions table, the life is 1 million engagements or more.

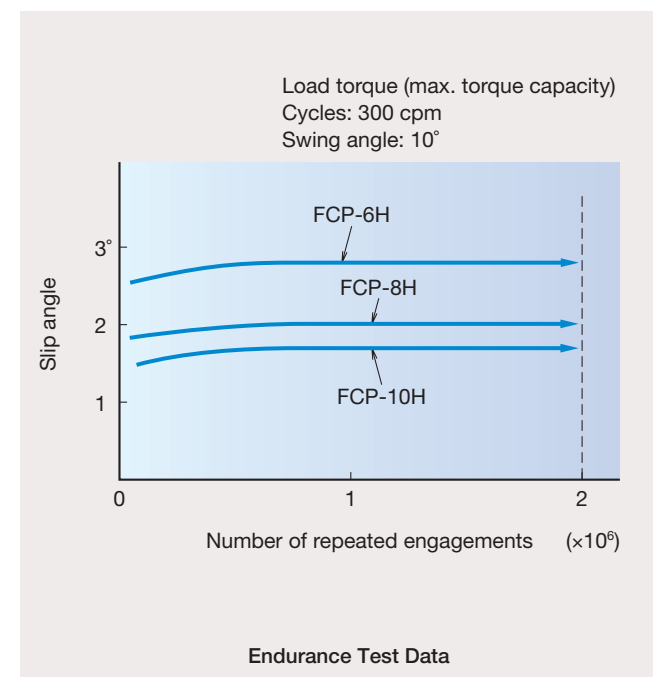

Endurance Test Data

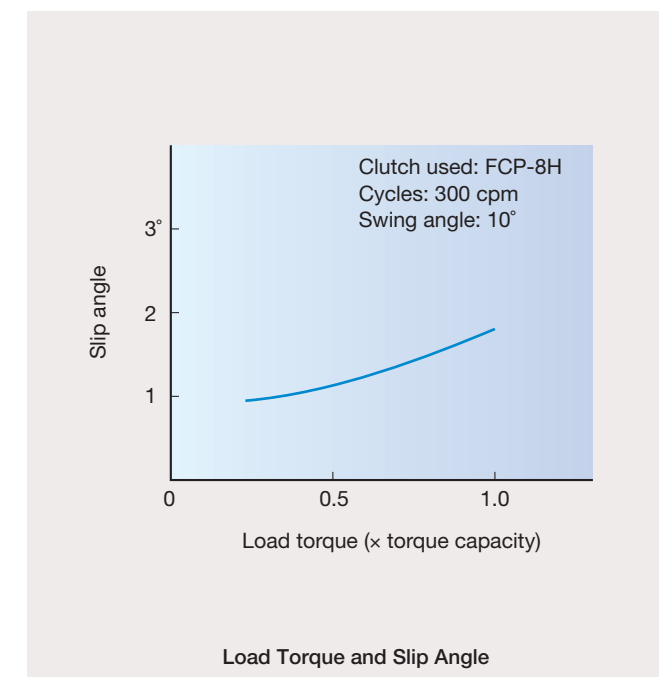

Load Torque and Slip Angle

FCP/DF type

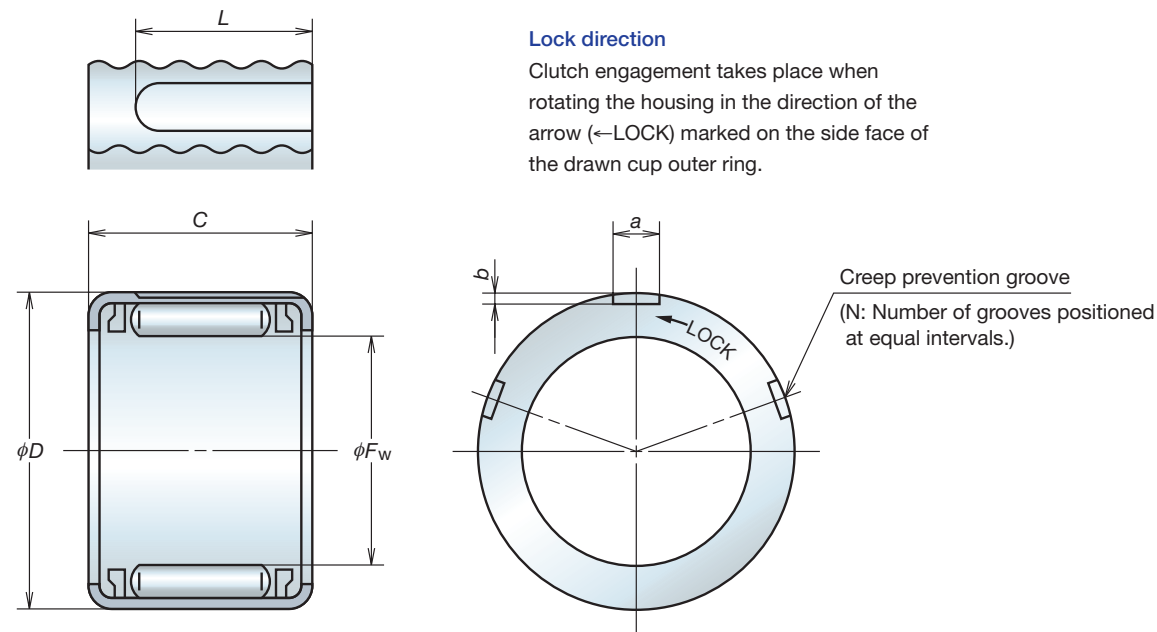

Roller Clutch Numbers	Boundary Dimensions/Part Dimensions (mm)							Lock Direction	Torque Capacities	Remarks
	F_w	D	C	a	b	L	N		(N·m)	
DF500401	4	8	6	1.0	0.25	4.0	5	←	0.13	With stainless steel spring
DF500408	4	8	6	1.0	0.25	4.0	5	→	0.13	With stainless steel spring
DF500609	6	10	8	1.2	0.25	5.5	3	←	0.44	
DF500610	6	10	8	1.2	0.25	5.5	3	→	0.44	
FCP-6H	6	12	11	1.5	0.25	8.5	5	←	0.90	
FCPC-6H	6	12	11	1.5	0.25	8.5	5	→	0.90	
FCP-8H	8	12	12	1.2	0.25	9.5	9	←	1.67	
FCPC-8H	8	12	12	1.2	0.25	9.5	9	→	1.67	
FCP-10H	10	14	12	1.2	0.25	9.5	5	←	2.26	
FCPC-10H	10	14	12	1.2	0.25	9.5	5	→	2.26	

Note: Stainless steel spring specifications are available for products with bore diameters (F_w) 6 mm and 8 mm

■ Features

1. Applicable to various types of housing

Able to use various types of integrated plastic housings according to requirements.

2. High durability

Offers superior durability due to outer ring using high precision-drawn material.

3. Cost effective

Rational design of parts results in low cost.

■ Configuration

Fig. 11 shows an example configuration of a roller clutch unit for a low-cost plastic housing.

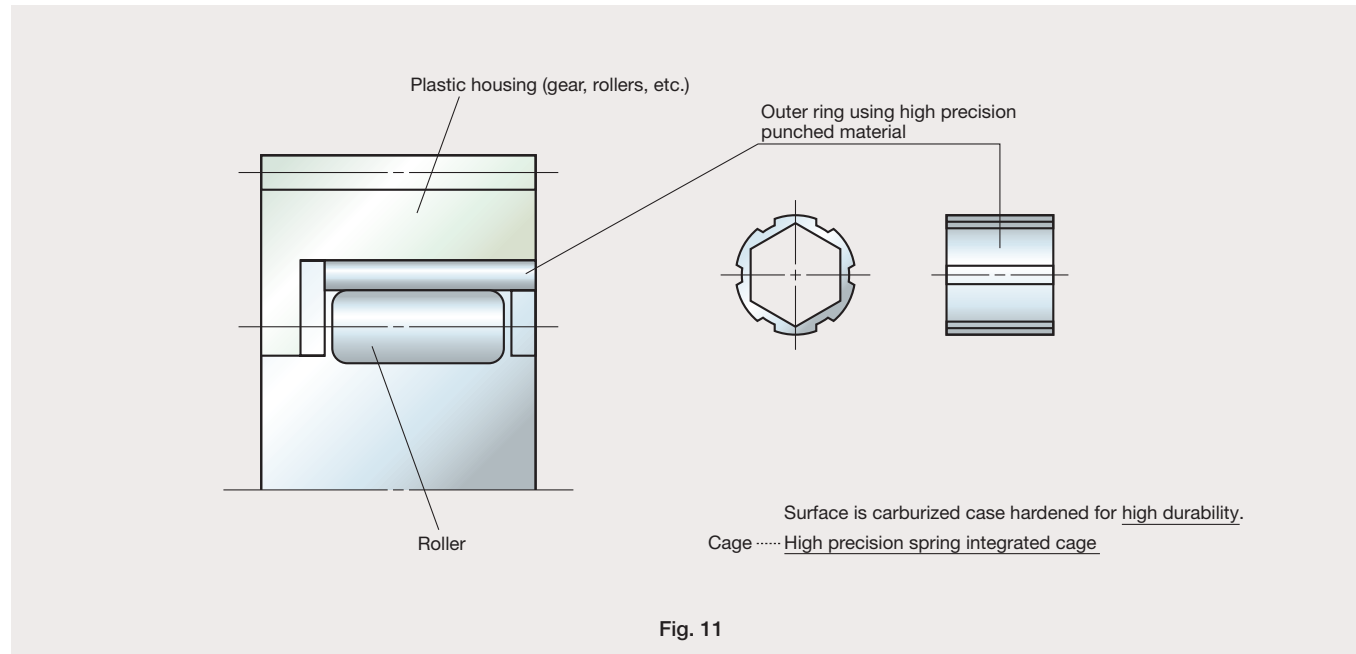
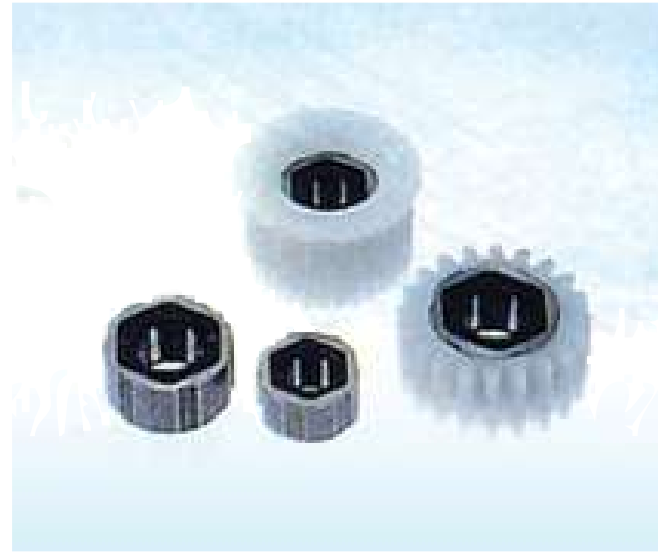

Fig. 11

■ Specifications and fitting of shaft and housing

Shaft and housing specification are ordinarily as follows:

Shaft/material: Metal such as S-C, SS-, SUS
Hardness HRC50 or more

Shaft/accuracy: Class h9

Shaft/surface hardness: 0.4 R_a

Housing: Integrated polyacetyl housing (rollers, gear, etc.);
gear precision conforms to *JGMA class 6.

*JGMA : Japan Gear Manufactures Association

FCU

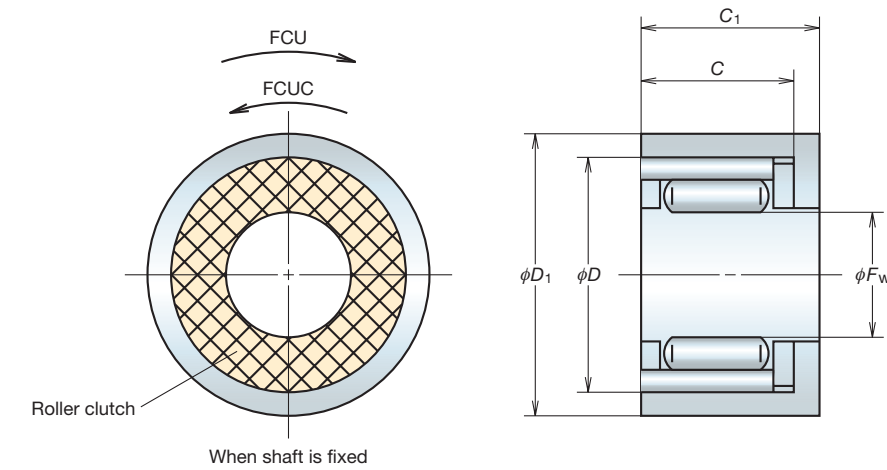

Roller Clutch Numbers	Clutch Dimensions (mm)			Unit Dimensions (mm) (min)		Torque Capacity (N·m)
	F _w	D	C	D ₁	C ₁	
FCU-6	6	12	6.5	14	8	0.51
FCUC-6	6	12	6.5	14	8	0.51
FCU-8	8	15	7.5	17	9	1.02
FCUC-8	8	15	7.5	17	9	1.02

■ Operating temperature

The operating temperature range of the roller clutch is -10 °C to 90 °C. Contact NSK if you plan to use the roller clutch beyond this range.

■ Life

With the torque capacity given in the dimensions table, the life is 1 million engagements or more.

■ Lubrication

The roller clutch is sealed with special grease and does not need to be replenished. Take steps to prevent ingress of other types of grease or foreign matter during operation.

