

TRASCO® COUPLINGS

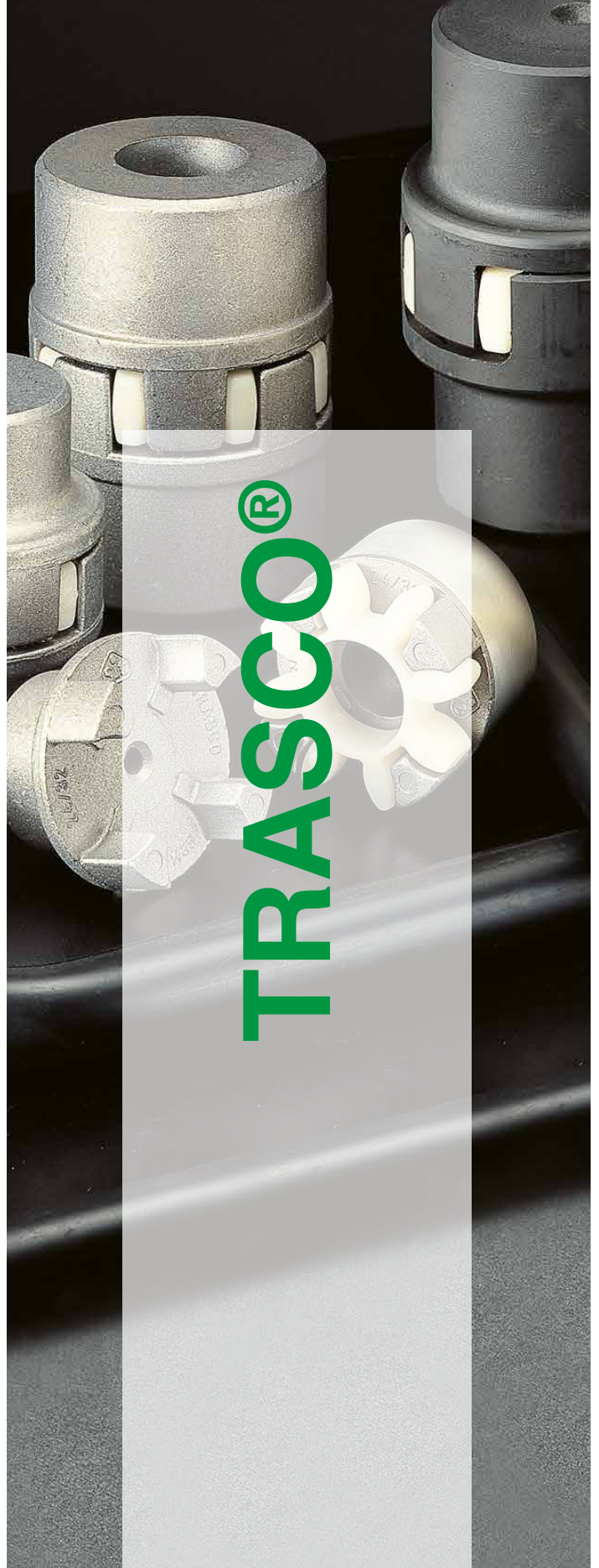

DRIVE
SOLUTIONS



TRASCO®

TRASCO® Couplings

Description

TRASCO® flexible coupling is the flexible and omocinetic coupling that assures the best performance in relation to the physical space occupied in its class. It has a very compact design and allows safe power transmission by absorbing peak loads and torsional vibrations. Moreover, the elastic design of the polyurethane gear ring compensates for angular and radial misalignments and also absorbs small shaft length variation. The involute profile of the gear ring teeth prevents high stress concentrations on reduced surfaces and the crowned profile and avoids the transmission of axial stress. The high duty factor of TRASCO® couplings is due to the fact that the elastic element works under compression and never under flexion.

TRASCO® couplings are suitable for working in both horizontal and in vertical positions and easily support any load variation or reversal motion. The two coupling halves are electrically insulated from each other.



Type "A"
execution
Ø hub reduced



Type "AL"
execution
long hub
Ø reduced



"AR" spider



Type "B"
execution



Type "BL"
execution
long hub



Type "GRB"
execution
for SER-SIT® taper bushing

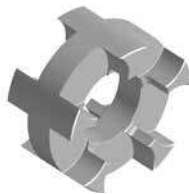

Type "GRS"
execution



Execution for SIT-LOCK® 8
locking devices



Type "GRF"
execution flanged

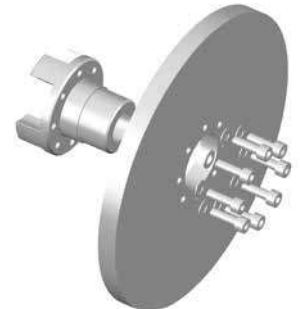

Type "GRFRD-GRFRT"
execution

ATEX Directive 2014/34/EU

It is possible to ask for specific certification for use in hazardous area according to ATEX Directive 2014/34/EU.

TRASCO® couplings are available with specific mounting/operating instruction manual and conformity. For information, please contact our technical office.

Hubs

TRASCO® flexible couplings consist of two precision machined metal hubs and an elastic gear ring (spider) which is resistant to oils, chemical agents, and heat.

Hubs are available in cast iron GG25 or aluminum and, in case of special request, in steel or cast iron GGG40.

Each hub is available in version "A" and "B" (in standard or long hub "L" version) which can accommodate different size of bores, leaving unchanged the performance and the technical features.

Note: It is possible to have aligned keyways upon inquiry.

Spider

The gear ring is made of a particular polyurethane resin which shows great advantages in comparison to the standard polyurethanes available on the market. The urethane compound of our polyurethane gear ring offers resistance to aging, hydrolysis, fatigue, and abrasion making it suitable for even the most demanding applications in high humidity conditions. It is self-dampening and shows a great resistance to the main chemical agents, acids, oils, and ozone.

Special types of gear rings are available in order to provide the right solution for each specific application covering a large range of temperatures and resisting specific chemical agents.

Standard spiders					
Standard spiders	Colors	Compound	Admissible temperature [°C]		Applications
			on work	peaks	
92 Sh A	Giallo	Poliuretano	from -40 to +90	from -50 to +120	the most of industrial application (low-mid power)
98 Sh A	Rosso	Poliuretano	from -30 to +90	from -40 to +120	high torque/narrow angular misalignment/torsional rigidity
64 Sh D	Verde	Poliuretano	from -30 to +110	from -30 to +130	dampened areas/internal combustion engines

Spiders for special applications					
Standard spiders	Colors	Compound	Admissible Temperature [°C]		Applications
			on work	peaks	
80 Sh A	Blue	Polyurethane	from -50 to +80	from -60 to +120	Applications with small loads and high misalignments
PA	Grey	Polyamide	from -20 to +110	from -30 to +150	high torsion rigidity/high temperature areas high resistance

Available on request spiders with different compound for special applications:

- High working temperature
- Heavy working conditions
- Heavy environment conditions
- Resistance to specific chemicals

TRASCO® coupling sizing

TRASCO® coupling sizing is made according to DIN 740/2. Couplings must be selected to ensure that the maximum admissible torque is never exceeded during operation.

It is necessary to have correct sizing, so that all conditions hereunder are respected.

Verification should be conducted on both nominal torque and maximum transmissible torque:

1) Verify the nominal torque

The nominal torque of the coupling must be greater than or equal to the nominal torque of the drive multiplied by the temperature safety factor.

$$T_{KN} \geq T_N \cdot S_\theta \quad [\text{Nm}]$$

where the nominal torque of the T_N motor side is obtained by the formula:

$$T_N = 9550 \frac{P_N}{n} \quad [\text{Nm}]$$

Where P_N is the motor nominal power in kW and n is the number of rpm.

2) Verify the maximum torque

The maximum torque of the coupling must be greater than the starting torque and multiplied by the temperature coefficients, starting frequency and shock frequency

$$T_{Kmax} \geq T_S \cdot S_\theta \cdot S_z \cdot S_u \quad [\text{Nm}]$$

3) Verify torque with reversal

In the case of torque with reversals in addition to 1) and 2), it must also be verified that the torque with reversals supportable by the T_{KW} , sia maggiore o uguale alla variazione di coppia T_w della trasmissione, corretta con il coefficiente di temperatura

$$T_{KN} \geq T_N \cdot S_\theta \quad [\text{Nm}]$$

In case of drives with high torsional vibrations (e.g. piston compressors, combustion engine) it is recommended to make a torsional vibration calculations in order to guarantee the correct functioning of the coupling. Please consult our technical office.

Shock load safety factor

Shock load type	S_u
Light	1,4
Medium	1,5
Hard	1,8

Shock load safety factor

T (°C)	-30 °C / +30 °C	+40 °C	+60 °C	+80 °C
S_θ	1	1,2	1,4	1,8

Safety factor for frequency of starting

Starts/h	0 ÷ 100	101 ÷ 200	201 ÷ 400	401 ÷ 800
S_z	1	1,2	1,4	1,6

Hub shaft connection check

Hub shaft connection must always be checked by the user. It is important to verify the maximum torque in the drive is lower than the torque which the hub shaft connection can bear. In case of keyway connection, it is important to verify the tensile strength of the hub material with the load which the keyway seat must transmit.

T_{KN}	Coupling nominal torque	Nm
T_{Kmax}	Coupling maximum torque	Nm
T_{KW}	Torque with reversal transmissible by the coupling	Nm
T_N	Motor nominal torque	Nm
T_S	Motor peak torque	Nm

T_w	Torque with reversal of the machine	Nm
S_θ	Temperature factor	
S_z	Start frequency factor	
S_u	Motor or driven-side shock factor	
P_N	Motor nominal torque	kW
n	Number of engine operating revolutions	rpm

Type of stress

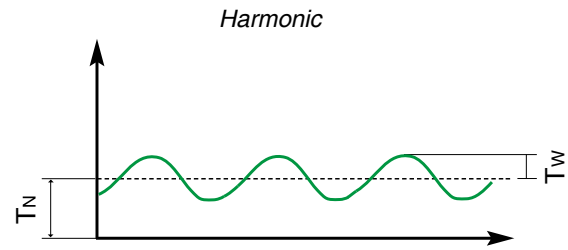
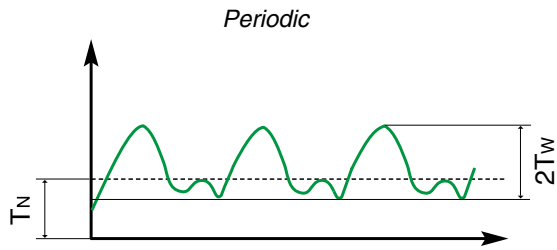

Misalignment

Size	ΔK_a [mm]	ΔK_r [mm]	ΔK_w [°]
19/24	1,2	0,20	1°30'
24/32	1,4	0,22	1°30'
28/38	1,5	0,25	1°30'
38/45	1,8	0,28	1°30'
42/55	2,0	0,32	1°30'
48/60	2,1	0,36	1°30'
55/70	2,2	0,38	1°30'
65/75	2,6	0,42	1°30'
75/90	3,0	0,48	1°30'
90/100	3,4	0,50	1°30'
100/110	3,8	0,52	1°30'
110/125	4,2	0,55	1°30'
125/145	4,6	0,60	1°30'
140/160	5,0	0,62	1°30'
160/185	5,7	0,64	1°30'
180/200	6,4	0,68	1°30'

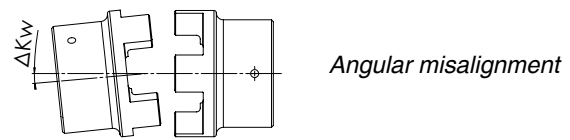
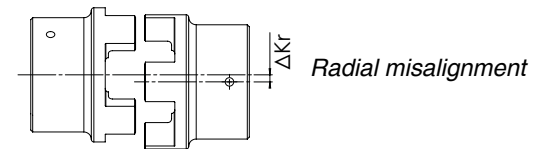
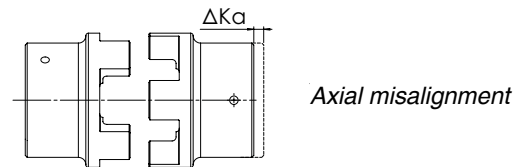

n=1500 rpm

The values shown in the table for radial and angular misalignment, must be corrected in case they are simultaneously acting on the coupling.

The sum of the admissible value (A) and the respective values shown in the table must be less than or equal to 1.

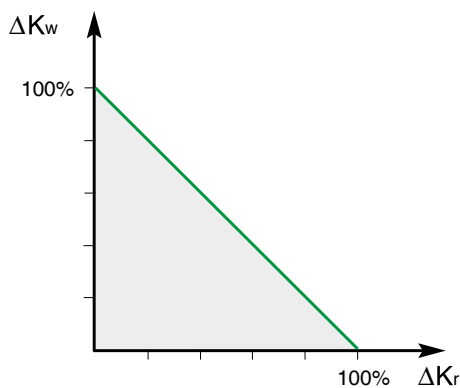

$$\frac{\Delta K_{rA}}{\Delta K_r} + \frac{\Delta K_{wA}}{\Delta K_w} \leq 1$$

ΔK_a	Maximum axial misalignment	mm
ΔK_r	Maximum radial misalignment	mm
ΔK_w	Maximum angular misalignment	°

Dynamic torsional rigidity

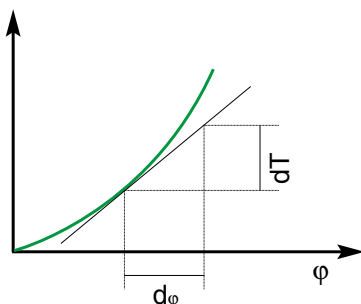

Dynamic torsional rigidity C_{Tdin} is the first derivate of the nominal torque of half coupling in respect to the torsion angle.

ϕ is the torsion angle of half coupling in respect to the second half. As a general rule, C_{Tdin} is greater than C_T and depends on the stress acting on the coupling.

TRASCO® Technical performances

The technical performances below refer to all types of TRASCO® executions and are valid for the indicated spiders when couplings are properly selected.

For particular applications needed, such as very high chemical resistance, spiders made of special material are available. Contact our Technical Department.

Size	Hardness spider		Torque			Max. speed		Dynamic torsional rigidity			
	Color	Shore	T _{KN} [Nm]	T _{Kmax} [Nm]	T _{KW} [Nm]	n (v=30m/s) [rpm]	n (v=40m/s) [rpm]	CTdin (1 T _{KN}) [Nm/rad]	CTdin (0,75 T _{KN}) [Nm/rad]	CTdin (0,5 T _{KN}) [Nm/rad]	CTdin (0,25 T _{KN}) [Nm/rad]
19/24	Yellow	92 Sh A	10	20	2,7	14000	19000	1280	1050	800	470
	Red	98 Sh A	17	34	4,4	14000	19000	2920	2390	1810	1070
	Green	64 Sh D	21	42	5,5	14000	19000	5350	4390	3320	1970
24/32	Yellow	92 Sh A	35	70	9	10600	14000	4860	3980	3010	1790
	Red	98 Sh A	60	120	16	10600	14000	9930	8140	6160	3650
	Green	64 Sh D	75	150	19,5	10600	14000	15110	12390	9370	5550
28/38	Yellow	92 Sh A	95	190	25	8500	11800	10900	8940	6760	4010
	Red	98 Sh A	160	320	42	8500	11800	26770	21950	16600	9840
	Green	64 Sh D	200	400	52	8500	11800	27520	22570	17060	10120
38/45	Yellow	92 Sh A	190	380	49	7100	9500	21050	17260	13050	7740
	Red	98 Sh A	325	650	85	7100	9500	48570	39830	30110	17850
	Green	64 Sh D	405	810	105	7100	9500	70150	57520	43490	25780
42/55	Yellow	92 Sh A	265	530	69	6000	8000	23740	19470	14720	8730
	Red	98 Sh A	450	900	117	6000	8000	54500	44690	33790	20030
	Green	64 Sh D	560	1120	145	6000	8000	79860	65490	49520	29350
48/60	Yellow	92 Sh A	310	620	81	5600	7100	36700	30090	22750	13490
	Red	98 Sh A	525	1050	137	5600	7100	65290	53540	40480	24000
	Green	64 Sh D	655	1310	170	5600	7100	95510	78320	59220	35100
55/70	Yellow	92 Sh A	410	820	107	4750	6300	50720	41590	31450	18640
	Red	98 Sh A	680	1250	178	4750	6300	94970	77880	58880	34900
	Green	64 Sh D	825	1650	215	4750	6300	107920	88500	66910	39660
65/75	Yellow	92 Sh A	625	1250	163	4250	5600	97130	79650	60220	35700
	Red	98 Sh A	950	1900	245	4250	5600	129510	106200	80300	47600
	Green	64 Sh D	1175	2350	305	4250	5600	151090	123900	93680	55530
75/90	Yellow	92 Sh A	1280	2560	333	3550	4750	113320	92920	70260	41650
	Red	98 Sh A	1950	3900	500	3550	4750	197500	161950	122450	72580
	Green	64 Sh D	2410	4820	325	3550	4750	248220	203540	153900	91220
90/100	Yellow	92 Sh A	2400	4800	624	2800	3750	190090	155870	117860	69860
	Red	98 Sh A	3600	7200	936	2800	3750	312200	256000	193560	114730
	Green	64 Sh D	4500	9000	1170	2800	3750	674520	553110	418200	247890
100/110	Yellow	92 Sh A	3300	6600	860	2500	3350	253080	207530	156910	93010
	Red	98 Sh A	4950	9900	1290	2500	3350	383260	314270	237620	140850
	Green	64 Sh D	6200	12400	1600	2500	3350	861170	706160	533930	316480
110/125	Yellow	92 Sh A	4800	9600	1250	2240	3000	311610	255520	193200	114520
	Red	98 Sh A	7200	14400	1870	2240	3000	690060	565850	427840	253600
	Green	64 Sh D	9000	18000	2340	2240	3000	1138590	933640	705920	418430
125/145	Yellow	92 Sh A	6650	13300	1730	2000	2650	474860	389390	294410	174510
	Red	98 Sh A	10000	20000	2600	2000	2650	1343640	1101790	833060	493790
	Green	64 Sh D	12500	25000	3250	2000	2650	1435380	1177010	889930	527500
140/160	Red	98 Sh A	12800	25600	3328	1800	2360	1424580	1168160	883240	523540
160/185	Red	98 Sh A	19200	38400	4992	1500	2000	2482230	2035430	1538980	912220
180/200	Red	98 Sh A	28000	56000	7280	1400	1800	3561450	2920400	2208100	1308840

Spider hardness	Torsion angle		Dampening factor Ψ (-)	Resonance factor V_R (-)
	j (T _{KN}) (°)	j (T _{Kmax}) (°)		
Yellow	3,2°	5°	0,8	7,9
Red	3,2°	5°	0,8	7,9
Green	2,5°	3,6°	0,75	8,5



TRASCO® couplings for motors according to IEC standards (spider hardness 92 shore)

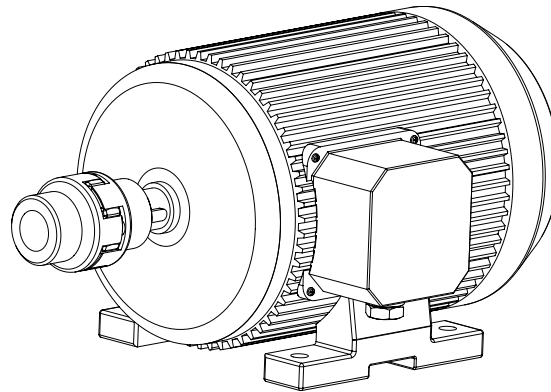

General purpose - TRASCO®

Size	3000 [1/min]				1500 [1/min]				1000 [1/min]				750 [1/min]				d x l [mm]					
	P _N [kW]	T _N [Nm]	Type	K	P _N [kW]	T _N [Nm]	Type	K	P _N [kW]	T _N [Nm]	Type	K	P _N [kW]	T _N [Nm]	Type	K	2 poles	4 - 6 - 8 poles				
80	0,75	2,5	19/24	9,2	0,55	3,7	19/24	6,2	0,37	3,9	19/24	5,8	0,18	2,5	19/24	9,2	19x40					
	1,1	3,7		6,2	0,75	5,1		4,5	0,55	5,8		3,9	0,25	3,5		6,5						
90 S	1,5	5		4,6	1,1	7,5		3	0,75	8		2,8	0,37	5,3		2,9	24x50					
90 L	2,2	7,4		3,1	1,5	10		2,3	1,1	12		6,6	0,55	7,9		2,9						
100 L	3	9,8	24/32	8,1	2,2	15	24/32	5,3	1,5	15	24/32	5,3	0,75	11	24/32	7,2	28x60					
112 M		13		6,1	4	27		4				1,5	15	5,3		1,1			16	5		
	132 S	5,5		18	28/38	12,7		5,5	36	28/38		6,3	3	30		28/38	7,6	2,2	30	28/38	7,6	38x80
7,5		25		9,2		4,6						4					40				4,1	
132 M			7,5	49		4,6	5,5	55	5,7		3	40	5,7	42x110								
	11	36	12,5	11		72	38/45	6,2	7,5		74	38/45	6				4	54	8,3			
15	49	9,1	6,2		7,5			74		5,5			74	6	5,5	74	6					
160 L	18,5	60	7,5	15	98	4,5		11	108	4,1	7,5		100	4,5	48x110							
180 M	22	71	8,7	18,5	121	5,1																
180 L				22	144	4,3	15	148	4,1	11	145	4,2	55x110									
200 L	30	97	42/55	6,3	30	196	42/55	3,1	18,5	181	42/55	3,4			15	198	42/55	3,1				
	37	120		5,1				22	215	2,8												
225 S					37	240		3							18,5	244		48/60	2,9	55x110 60x140		
225 M	45	145		4,2	45	292		2,4	30	293		2,4	22	290	2,4							
250 M	55	177	48/60	4	55	356	55/70	2,4	37	361	55/70	2,3	30	392	65	2,6	60x140	65x140				
280 S	75	241	55/70	3,5	75	484	75/90	5,1	45	438	75	5,7	37	483	75	5,1	75x140					
280 M	90	289		2,9	90	581		4,3	55	535		4,6	45	587		4,2						
315 S	110	353		2,4	110	707	75/90	3,5	75	727		75/90	3,4	55	712	75/90	3,5	65x140 80x170				
315 M	132	423		5,9	132	849		2,9	90	873			2,8	75	971		6,2					
315 L	160	513	75/90	4,8	160	1030	90/100	5,9	110	1070	90		5,7	90	1170	90	5,2	75x140 95x170				
	200	641		3,9	200	1290		4,7	132	1280			4,7	110	1420		4,2					
355 L	250	801		3,1	250	1610	90/100	3,7	160	1550		90/100	3,9	132	1710	90/100	3,5	80x170 95x170				
	315	1010		6				315	2020	3			250	2420	100		2,5			200	2580	100
400 L	355	1140	90/100	5,3	355	2280		100	2,6	315	3040	100	2	250	3220	100	1,8	80x170	110x210			
	400	1280		4,7	400	2560			2,3													

P _N	Motor nominal torque	kW
T _N	Motor nominal torque	Nm
K	Safety factor	
d x l	Motor shaft's end	mm

TRASCO® “GR” base program

The basic series of TRASCO® GR hubs of the TRASCO® coupling is manufactured in various designs and in different materials. For particularly heavy-duty applications, the use of hubs made of nodular cast iron or steel is suggested. Please consult our technical department in this regard. **ATEX-compliant couplings are available from stock.**

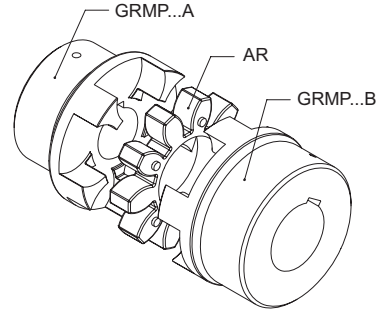
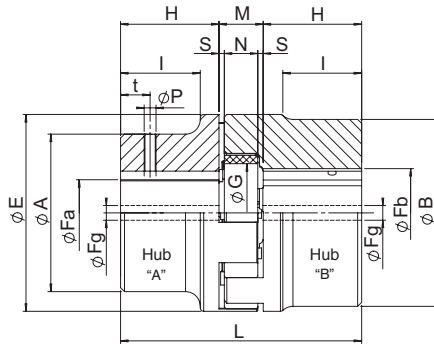

Dimensional specification

Size	Fa max [mm]	Fb max [mm]	Prebored Fg [mm] executions				E [mm]	A [mm]	B [mm]	A execution [mm]			B execution [mm]			AL execution [mm]			BL execution [mm]			M [mm]	S [mm]	N [mm]	G [mm]
			A	B	AL	BL				H	L	I	H	L	I	H	L	I	H	L	I				
19/24	-	24	-	-	-	-	40	-	40	-	-	-	25	66	-	-	-	-	50	-	-	16	2	12	18
24/32	24	32	8	10	8	10	55	40	55	30	78	24	30	78	-	50	118	44	60	116	-	18	2	14	27
28/38	28	38	8	10	8	10	65	48	65	35	90	28	35	90	-	60	140	53	80	180	-	20	2,5	15	30
38/45	38	45	10	12	14	14	80	66	80	45	114	37	45	114	-	80	184	72	110	244	-	24	3	18	38
42/55	42	55	10	12	16	16	95	75	95	50	126	40	50	126	-	110	246	100	110	246	-	26	3	20	46
48/60	48	60	12	12	16	16	105	85	105	56	140	45	56	140	-	110	248	99	140	308	-	28	3,5	21	51
55/70	55	70	15	15	16	16	120	98	120	65	160	52	65	160	-	110	250	97	140	310	-	30	4	22	60
65/75	65	75	15	15	20	20	135	115	135	75	185	61	75	185	-	140	315	126	140	315	-	35	4,5	26	68
75/90	75	90	15	15	22	22	160	135	160	85	210	69	85	210	-	140	320	124	170	380	-	40	5	30	80
90/100	90	100	20	20	30	30	200	160	180	100	245	81	100	245	81	170	385	151	210	465	191	45	5,5	34	100
100/110	115	-	45	-	-	-	225	180	-	110	270	89	110	270	-	-	-	-	-	-	-	50	6	38	113
110/125	125	-	55	-	-	-	255	200	-	120	295	96	120	295	-	-	-	-	-	-	-	55	6,5	42	127
125/145	145	-	55	-	-	-	290	230	-	140	340	112	140	340	-	-	-	-	-	-	-	60	7	46	147
140/160	160	-	55	-	-	-	320	255	-	155	375	124	-	-	-	-	-	-	-	-	-	65	7,5	50	165
160/185	185	-	75	-	-	-	370	290	-	175	425	140	-	-	-	-	-	-	-	-	-	75	9	57	190
180/200	200	-	80	-	-	-	420	325	-	195	475	156	-	-	-	-	-	-	-	-	-	85	10,5	64	220

Material: 19/24 sintered steel - from 24/32 to 90/100 cast iron - from 100/110 ductile iron.
Keyway according to DIN 6885 sheet 1 - JS9

Dimensional specification hubs in aluminum

Size	Fa max [mm]	Fb max [mm]	Prebored Fg [mm] executions		E [mm]	A [mm]	B [mm]	L [mm]	H [mm]	M [mm]	S [mm]	N [mm]	I [mm]	G [mm]	t [mm]	P [mm]
			A	B												
19/24	-	24	-	-	40	40	40	66	25	16	2	12	-	18	10	M5
24/32	24	32	-	-	55	40	55	78	30	18	2	14	24	27	10	M5
28/38	28	38	12	28	65	48	65	90	35	20	2,5	15	28	30	15	M6
38/45	38	45	22	38	80	66	77	114	45	24	3	18	37	38	15	M8
42/55	-	55	-	22	95	-	95	126	50	26	3	20	-	46	20	M8
48/60	-	60	-	30	105	-	105	140	56	28	3,5	21	-	51	20	M8

Hub **GRMP 48/60 AL F48**

GRMP: Standard TRASCO® hub
GRMALU: TRASCO® aluminum hub

Size

A: execution A
B: execution B
AL: long execution A
BL: long execution B

F...: diameter of the bore

Spider **AR 48/60 R**

Spiderper TRASCO®

Size

92 Sh A (yellow) if not indicated
R: 98 Sh A (red)
V: 64 Sh D (green)

Stock range

Hubs with finished bore H7, keyway (DIN 6885 sheet 1 - JS9), setscrew

Type	19/24		24/32				28/38				38/45				42/55				48/60			55/70		65/75		75/90		90/100	
Material*	ALU	AC	ALU	GG	ALU	GG	ALU	GG	ALU	GG	ALU	GG	ALU	GG	B	A	B	B	A	B	GG	GG	GG	GG	GG	GG	GG	GG	
Hub execution	B	B	A	B	A	B	A	B	A	B	A	B	A	B	B	A	B	B	A	B	A	B	A	B	A	B	A	B	
Stock range bore [mm]	10	•	•																										
	11	•	•																										
	12	•	•																										
	14	•	•	•		•		•		•																			
	15	•	•	•		•		•		•																			
	16	•	•	•		•		•		•																			
	18		•	•		•		•		•																			
	19	•	•	•		•		•		•			•																
	20	•	•	•		•		•		•																			
	22			•		•		•		•																			
	24	•	•	•	•	•	•	•		•		•						•											
	25				•		•	•		•		•			•	•													
	28				•		•	•		•		•			•	•													
	30						•		•	•		•			•	•						•		•					
	32						•			•	•				•	•						•	•						
	35									•	•	•			•	•						•	•						
	38									•	•	•			•	•						•	•					•	
	40											•		•	•	•						•	•			•			
	42											•		•	•	•						•	•			•			
	45												•		•	•						•	•			•		•	
	48													•		•	•					•	•			•		•	
	50														•	•	•					•	•			•		•	•
	55															•	•	•				•	•			•		•	•
	60																	•		•		•	•			•		•	•
65																					•	•			•		•	•	
70																					•				•	•	•	•	
75																							•		•	•	•	•	
80																									•	•	•	•	
85																										•	•	•	
90																										•	•	•	
95																												•	
100																												•	

*= ALU: Aluminum - AC: Steel - GG: Cast iron

Setscrews types for single hubs

Hub dimension	P	t [mm]	Screw tightening torque [Nm]
19/24	M5	10	2
24/32	M5	10	2
28/38	M6	15	4,8
38/45	M8	15	10
42/55	M8	20	10
48/60	M8	20	10
55/70	M10	20	17
65/75	M10	20	17
75/90	M10	25	17
90/100	M12	30	40
100/110	M12	30	40
110/125	M16	35	80
125/145	M16	40	80
140/160	M20	45	140
160/185	M20	50	140
180/200	M20	50	140

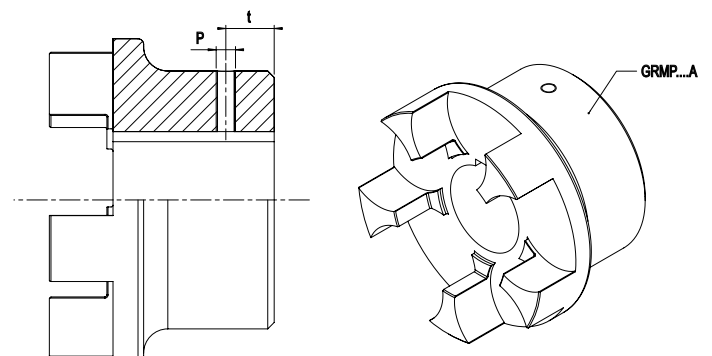

TRASCO® couplings “GRB” series for SER-SIT® taper bushing

TRASCO® couplings type GRB for taper bushing SER-SIT®, are manufactured in cast iron GG25. They combine the typical high performances of standard TRASCO® couplings with the advantages of easy mounting and dismounting offered by the taper bushing SER-SIT®.

These hubs are manufactured in two different mounting executions:

- B1: installing of taper bushing from outside
- B2: installing of taper bushing from inside (not available for size 90/100)

The GRB execution eliminate the problem of fitting corrosion, making it suitable for all type of machinery. Hubs type B1 may be axially moved for spider replacement. **ATEX-compliant couplings are available from stock.**

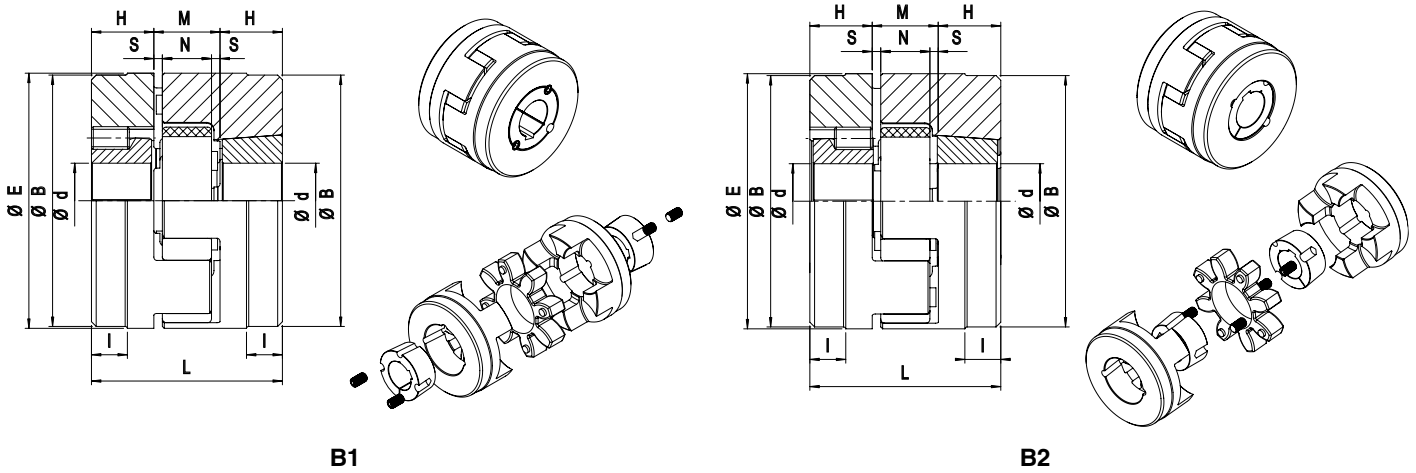

Size	Taper bushing	E [mm]	B [mm]	L [mm]	H [mm]	M [mm]	S [mm]	N [mm]	I [mm]
28/38	1108	65	65	66	23	20	2,5	15	-
38/45	1108	80	78	70	23	24	3	18	15
42/55	1610	95	94	78	26	26	3	20	16
48/60	1615	105	104	106	39	28	3,5	21	28
55/70	2012	120	118	96	33	30	4	22	20
65/75	2012	135	133	101	33	35	4,5	26	19
75/90	2517	160	158	130	45	40	5	30	36
90/100*	3535	200	180	223	89	45	5,5	34	70

*Only “B1” execution

SER-SIT® taper bushing type	Diameter of the bore																Transmissible torque [Nm]	Transmittable friction torque											
																		Ø bore [mm]	[Nm]										
1108	[mm]	11	12	14	15	16	17	18	19	20	22	24	25	26	27	28*	150	12 - 19	28 - 49										
	[pollici]	3/8	1/2	5/8	3/4	7/8	1	1 1/8*											24 - 28	64 - 79									
1610	[mm]	12	14	15	16	18	19	20	22	24	25	26	28	30	32	35	38	40	42	490	19 - 24	98 - 135							
	[pollici]	3/8	1/2	5/8	3/4	7/8	1	1 1/8	1 1/4	1 3/8	1	1 1/2	1 5/8											38 - 42	240 - 265				
1615	[mm]	12	14	15	16	18	19	20	22	24	25	26	28	30	32	35	38	40	42*	490	19 - 24	98 - 135							
	[pollici]	1/2	5/8	3/4	7/8	1	1 1/8	1 1/4	1 3/8	1 1/2	1 5/8*											38 - 42	240 - 265						
2012	[mm]	14	15	16	18	19	20	22	24	25	26	28	30	32	35	38	40	42	45	48	50	800	24 - 38 - 42	65 - 310 - 340					
	[pollici]	5/8	3/4	7/8	1	1 1/8	1 1/4	1 3/8	1 1/2	1 5/8	1 3/4	1 7/8	2											48 - 50	400 - 420				
2517	[mm]	18	19	20	22	24	25	28	30	32	35	38	40	42	45	48	50	55	60	65*	1300	24 - 38 - 42	220 - 380 - 430						
	[pollici]	3/4	7/8	1	1 1/8	1 1/4	1 3/8	1 1/2	1 5/8	1 3/4	1 7/8	2	2 1/8	2 1/4	2 3/8	2 1/2											48 - 55 - 60	510 - 600 - 670	
3535	[mm]	25	35	38	40	42	45	48	50	55	60	65	70	75	80	85	90	5000	42 - 60	1000 - 1580									
	[pollici]	1 1/2	1 5/8	1 3/4	1 7/8	2	2 1/8	2 1/4	2 3/8	2 1/2	2 5/8	2 3/4	2 7/8	3	3 1/8	3 1/4	3 3/8		3 1/2										

Taper bushing having bore diameters in bold type are made in steel instead of cast iron.

* = reduced keyway

Hub	GRMB 48/60 B2	Spider	AR 48/60 R
GRMB: TRASCO® GRMB for taper bushing		TRASCO® spider	
Size		Size	
B1: execution B1 B2: execution B2		92 Sh A (yellow) if not indicated R: 98 Sh A (red) V: 64 Sh D (green)	

TRASCO® couplings “GRCAL” series for use with SIT-LOCK® 8

This execution has been introduced to incorporate advantages offered by the SIT-LOCK® 8 locking elements in the shaft-hub connection. The system allows for a quick, safe and backlash free mounting without the use of keyway and eliminating the need for lock washers, spacers and stop rings. Many different solutions may be created to solve all kinds of application needs. We include hereunder a very useful example. In fact, the same hub bore allows the fitting of different shaft diameters.

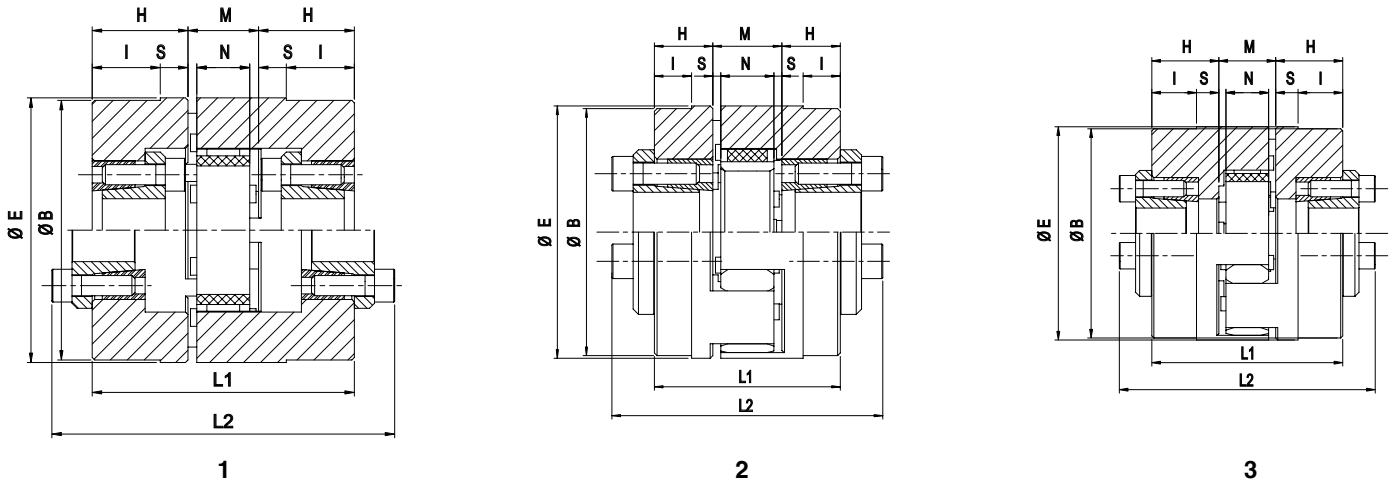

Size	Internal bore diameter of the locking device d [mm]	External bore diameter of the locking device D [mm]	H [mm]	E [mm]	B [mm]	L1 [mm]	L2 [mm]	M [mm]	S [mm]	N [mm]	I [mm]	Material*	Fig.
38/45	14 - 16 - 18 - 19 - 20 - 22 - 24 - 25 - 28 - 30	55	30	80	78	84	116	24	3	18	22	AC	3
42/55	14 - 16 - 18 - 19 - 20 - 22 - 24 - 25 - 28 - 30	55	22	95	93	70	102	26	3	20	14	GS-400	2
	24 - 25 - 28 - 30 - 32 - 35 - 38 - 40	65	32			90	122				22	AC	3
48/60	14 - 16 - 18 - 19 - 20 - 22 - 24 - 25 - 28 - 30	55	38	105	103	104	136	28	3,5	21	27	GS-400	1
	24 - 25 - 28 - 30 - 32 - 35 - 38 - 40	65	33			94	126				22	AC	3
55/70	14 - 16 - 18 - 19 - 20 - 22 - 24 - 25 - 28 - 30	55	38	120	118	106	138	30	4	22	25	GG25	1
	24 - 25 - 28 - 30 - 32 - 35 - 38 - 40	65	38			106	138				25	GS-400	1
	30 - 32 - 35 - 38 - 40 - 42 - 45 - 48 - 50	80	38			106	138				25	AC	3
65/75	14 - 16 - 18 - 19 - 20 - 22 - 24 - 25 - 28 - 30	55	38	135	133	111	143	35	4,5	26	24	GG25	1
	24 - 25 - 28 - 30 - 32 - 35 - 38 - 40	65	38			111	143				24	GS-400	1
	30 - 32 - 35 - 38 - 40 - 42 - 45 - 48 - 50	80	25			85	117				11	GS-400	2
75/90	14 - 16 - 18 - 19 - 20 - 22 - 24 - 25 - 28 - 30	55	38	160	158	116	148	40	5	30	22	GG25	1
	24 - 25 - 28 - 30 - 32 - 35 - 38 - 40	65	38			116	148				22	GG25	1
	30 - 32 - 35 - 38 - 40 - 42 - 45 - 48 - 50	80	41			122	154				25	GS-400	1
90/100	14 - 16 - 18 - 19 - 20 - 22 - 24 - 25 - 28 - 30	55	38	200	180	121	153	45	5,5	34	19	GG25	1
	24 - 25 - 28 - 30 - 32 - 35 - 38 - 40	65	38			121	153				19	GG25	1
	30 - 32 - 35 - 38 - 40 - 42 - 45 - 48 - 50	80	41			127	159				22	GG25	1

*= AC: steel / GG 25: cast iron 25 / GS-400: Spheroidal cast-iron 400

Hub **GRMC 48/60**

GRMC: TRASCO® hub for SIT-LOCK® 8

Size

Spider **AR 48/60 R**

TRASCO® spider

Size

Yellow if not indicated; R: red; V: green

Locking device **CAL 8 F20 / 55**

SIT-LOCK®

Size

Bore diameter

External bore diameter

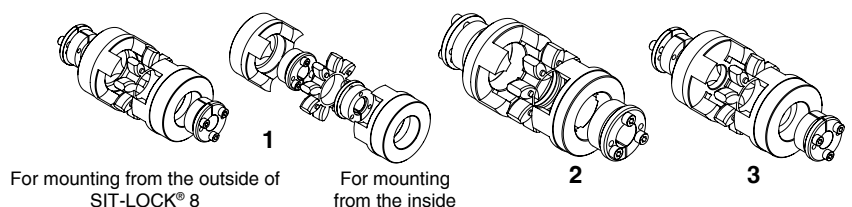

General purpose - TRASCO®

TRASCO® couplings “GRL” series with intermediate shaft

The GRL series allows the joining of two shafts (even very distant) through two TRASCO® couplings and an intermediate shaft (length “Lw”) of customized dimension. The presence of two polyurethane rings allows high dampening capability and greater radial misalignments. As a standard, hubs are made of cast iron, while shafts are from steel; though, different materials can be used, according to different applications.

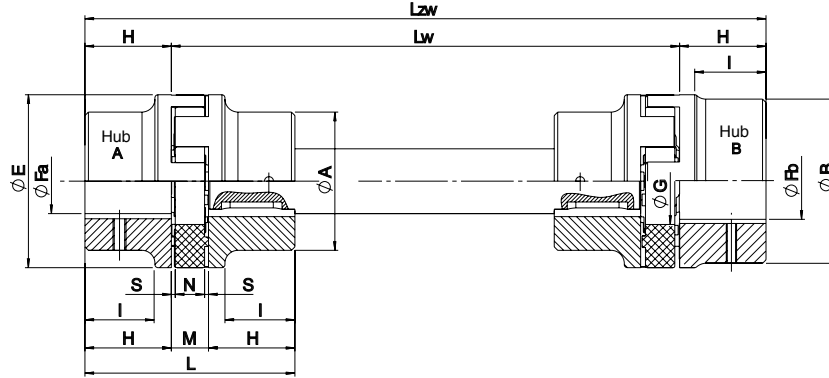

Size	Fa [mm]	Fb [mm]	E [mm]	A [mm]	B [mm]	H [mm] execution			L [mm]		M [mm]	S [mm]	N [mm]	I [mm] execution				G [mm]
						A-B	AL	BL	A-B	AL-BL				A	B	AL	BL	
24/32	9 - 24	11 - 32	55	40	55	30	50	60	78	128	18	2	14	24	-	44	-	27
28/38	9 - 28	11 - 38	65	48	65	35	60	80	90	160	20	2,5	15	28	-	53	-	30
38/45	11 - 38	13 - 45	80	66	80	45	80	110	114	214	24	3	18	37	-	72	-	38
42/55	11 - 42	13 - 55	95	75	95	50	110	110	126	246	26	3	20	40	-	100	-	46
48/60	13 - 48	13 - 60	105	85	105	56	110	140	140	278	28	3,5	21	45	-	99	-	51
55/70	16 - 55	16 - 70	120	98	120	65	110	140	160	280	30	4	22	52	-	97	-	60
65/75	16 - 65	16 - 75	135	115	135	75	140	140	185	315	35	4,5	26	61	-	126	-	68
75/90	16 - 75	16 - 90	160	135	160	85	140	170	210	350	40	5	30	69	-	124	-	80
90/100	21 - 90	21 - 100	200	160	180	100	170	210	245	425	45	5,5	34	81	81	151	191	100
100/110	46 - 115	-	225	180	-	110	-	-	270	-	50	6	38	89	-	-	-	113
110/125	56 - 125	-	255	200	-	120	-	-	295	-	55	6,5	42	96	-	-	-	127
125/145	56 - 145	-	290	230	-	140	-	-	340	-	60	7	46	112	-	-	-	147

Keyway according to DIN 6885 sheet 1 - JS9

Coupling configurator

Coupling code	Item	Type	Execution	Bore diameter	Order example	
GRL38/45	Hub 1	GR	A-B-AL-BL	F...	GRMP38/45AF35	
		GRB	B1-B2	F...		
		GRCAL	-	F...		
	Spider 1	AR	G-R-V	-	AR38/45V	
	Distance between two side shafts Lw					Lw = 1200 mm
	Spider 2	AR	G-R-V	-	AR38/45V	
	Hub 2	GR	A-B-AL-BL	F...	GRMP38/45BF40	
GRB		B1-B2	F...			
GRCAL		-	F...			

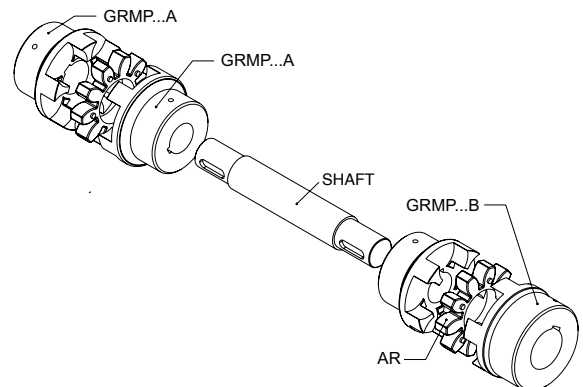

TRASCO® couplings “GRL CAL3” series with intermediate shaft

The GRL CAL3 series allows the joining of two shafts (even two spaced) through two TRASCO® couplings and an intermediate shaft (length “LR2”) of customized dimension, mounted with shrink discs on the hubs.

The presence of two polyurethane elements allows high dampening capability and greater radial misalignments.

As a standard, hubs are made of cast iron, while shafts are made of steel; though different materials can be used according to different applications.

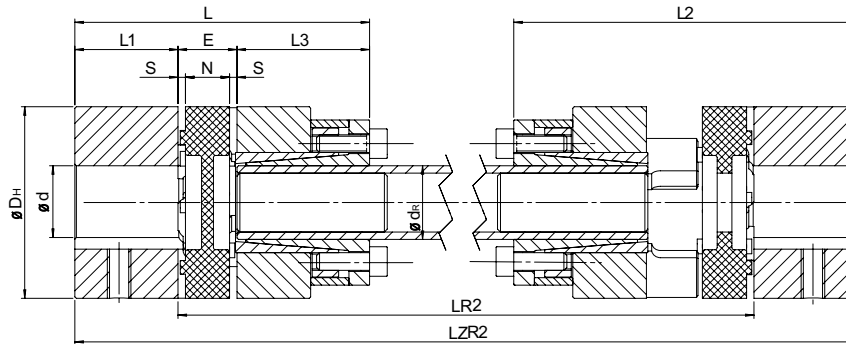

Size	External hub		Dimensions [mm] GRL-CAL3											Internal hub			
	dmin	dmax	DH	L1	L3	L	E	N	s	L2	LR2 min.	LZR2	Intermediate shaft		SIT-LOCK® 3 locking device		
													dR	C [Nm/Rad · m]	Type	Screw Din 912-12.9 M · L	TA [Nm]
14	4	15	30	11	26	50	13	10	1,5	61,5	109	LR2+22	10x2.0	68,36	10x16	M4X10	4,9
19/24	6	24	40	25	26	67	16	12	2	81	120	LR2+50	12x2.0	130	12x18	M4X10	4,9
24/32	8	28	55	30	38	86	18	14	2	102	156	LR2+60	20x3.0	954,9	20x28	M6X18	17
28/38	10	38	65	35	45	100	20	15	2,5	117,5	177	LR2+70	25x2.5	1811	25x34	M6X18	17
38/45	12	45	80	45	45	114	24	18	3	135	192	LR2+90	32x3.5	5167	32x43	M6X18	17
42/55	14	55	95	50	52	128	26	20	3	151	214	LR2+100	40x4.0	11870	40x53	M6X18	17
48/60	15	60	105	56	70	154	28	21	3,5	178,5	261	LR2+112	45x4.0	17486	45x59	M8X22	41
55/70	20	74	120	65	80	175	30	22	4	201	288	LR2+130	55x4.0	33543	55x71	M8X22	41
65/75	22	80	135	75	80	190	35	26	4,5	220,5	307	LR2+150	60x4.0	44362	60x77	M8X22	41

Keyway according to DIN 6885 sheet 1 - JS9

Coupling configurator

Coupling code	Item	Type	Execution	Bore diameter	Order example
GRLC38/45	Hub 1	GR	A-B-AL-BL	F...	GRMP38/45AF35
		GRB	B1-B2	F...	
		GRCAL	-	F...	
	Spider 1	AR	G-R-V	-	AR38/45V
	Distance between two side shafts LR2				LR2 = 1200 mm
	Spider 2	AR	G-R-V	-	AR38/45V
	Hub 2	GR	A-B-AL-BL	F...	GRMP38/45BF40
GRB		B1-B2	F...		
GRCAL		-	F...		

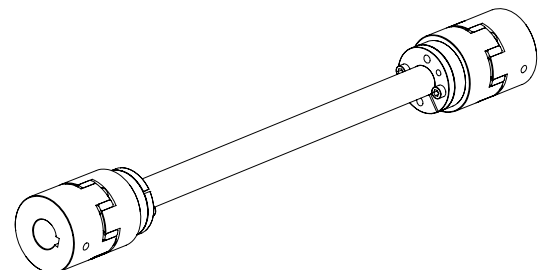

TRASCO® couplings “GRF” flange series

The GRF series with flanges has been developed for applications on heavy machinery and to combine different shafts and flange solutions. There are different assembling options:

Flange-flange: using two hubs type “CF”

Flange-shaft: using one hub Trasco standard “GR” and one hub type “CF”

Shaft-shaft: using two hubs type “CFF”, allows the replacement of the elastic element without dismounting of either motor-machine or driven-machine.

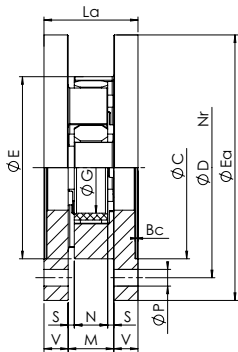

flange - flange

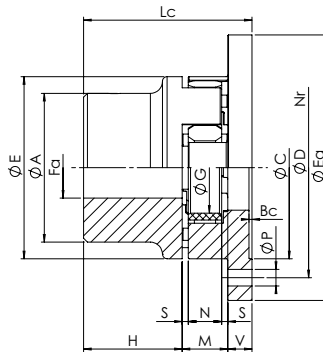

flange - shaft

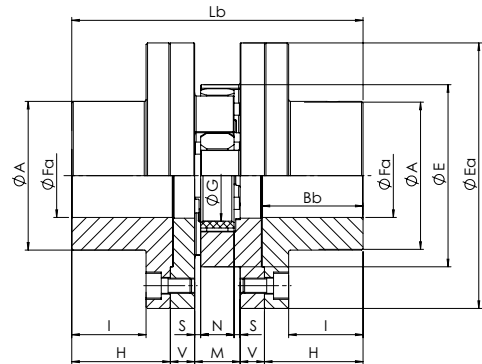

shaft - shaft

Size	Fa min [mm]	Fa max [mm]	E [mm]	Ea [mm]	A [mm]	C [mm]	D [mm]	N° viti	P [mm]	G [mm]	H [mm]	Bb [mm]	Bc [mm]	I [mm]	V [mm]	M [mm]	S [mm]	N [mm]	La [mm]	Lb [mm]	Lc [mm]
19/24	6	19	40	65	40/32	40	50	5	4,5	18	25	26	1,5	17	8	16	2	12	32	82	49
24/32	8	24	55	80	55/40	55	65	5	4,5	27	30	31	1,5	22	8	18	2	14	34	94	56
28/38	10	28	65	100	65/48	65	80	6	6,5	30	35	36	1,5	25	10	20	2,5	15	40	110	65
38/45	12	38	80	115	66	80	95	6	6,5	38	45	46	1,5	35	10	24	3	18	44	134	79
42/55	14	42	95	140	75	95	115	6	9	46	50	51	2	38	12	26	3	20	50	150	88
48/60	15	48	105	150	85	105	125	8	9	51	56	57	2	44	12	28	3,5	21	52	164	96
55/70	20	55	120	175	98	120	145	8	11	60	65	66	2	49	16	30	4	22	62	192	111
65/75	22	65	135	190	115	135	160	10	11	68	75	76	2	59	16	35	4,5	26	67	217	126
75/90	30	75	160	215	135	160	185	10	14	80	85	87	2,5	66	19	40	5	30	78	248	144
90/100	40	90	200	260	160	200	225	12	14	100	100	102	3	80	20	45	5,5	34	85	285	165
100/110	45	115	225	285	180	225	250	12	14	113	110	112	4	85	25	50	6	38	100	320	185
110/125	55	125	255	330	200	255	290	12	18	127	120	122	4	94	26	55	6,5	42	107	347	201
125/145	55	145	290	370	230	290	325	16	18	147	140	142	5	110	30	60	7	46	120	400	230

Keyway according to DIN 6885 sheet 1 - JS9. Material GJS400.

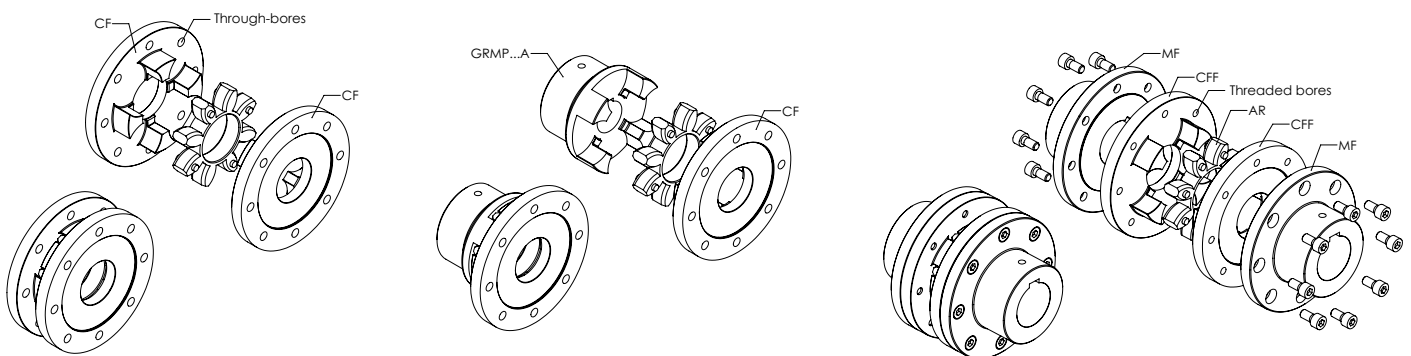

Hub	GRF	CF	48
GRF: flange series			
CF: Flange “CF” execution			
CFF: Flange “CFF” execution			
Size			

TRASCO® couplings “GRF C” flange series

The GRF C series has the same characteristics as the BF series, while being compact in dimension.

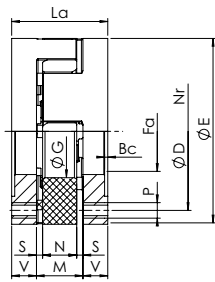

flange - flange

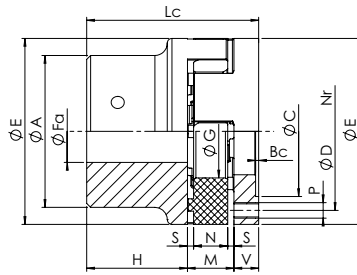

flange - shaft

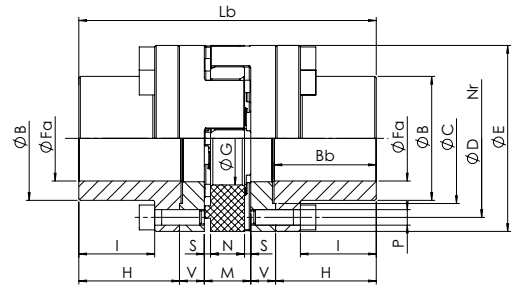

shaft - shaft

Size	Fa min [mm]	Fa max [mm]	E [mm]	A [mm]	B [mm]	H [mm]	I [mm]	La [mm]	Lb [mm]	Lc [mm]	V [mm]	M [mm]	S [mm]	N [mm]	Bb [mm]	Bc [mm]	G [mm]	D [mm]	N° viti	C [mm]	P [mm]
24/32	8	24	55	40	36	30	22	34	94	56	8	18	2	14	31	1,5	27	45	8	36	M5
28/38	10	28	65	48	42	35	25	40	110	65	10	20	2,5	15	36	1,5	30	54	8	44	M6
38/45	12	38	80	66	52	45	35	44	134	79	10	24	3	18	46	1,5	38	66	8	54	M8
42/55	14	42	95	75	62	50	38	50	150	88	12	26	3	20	51	2	46	80	12	65	M8
48/60	15	48	105	85	70	56	44	52	164	96	12	28	3,5	21	57	2	51	90	12	75	M8
55/70	20	55	120	98	80	65	49	62	192	111	16	30	4	22	66	2	60	102	8	84	M10
65/75	22	65	135	115	94	75	59	67	217	126	16	35	4,5	26	76	2	68	116	12	96	M10
75/90	30	75	160	135	108	85	66	78	248	144	19	40	5	30	87	2,5	80	136	15	112	M12
90/100	40	90	200	160	142	100	80	85	285	165	20	45	5,5	34	102	3	100	172	15	145	M16
100/110	45	115	225	180	158	110	85	100	320	185	25	50	6	38	112	4	113	195	15	165	M16
110/125	55	125	255	200	178	120	94	107	347	201	26	55	6,5	42	122	4	127	218	15	180	M20
125/145	55	145	290	230	206	140	110	120	400	230	30	60	7	46	142	5	147	252	15	215	M20
125/145	55	145	290	370	230	290	325	16	18	147	140	142	5	110	30	60	7	46	120	400	230

Keyway according to DIN 6885 sheet 1 - JS9. Material GJS400 (Spheroidal graphite iron).

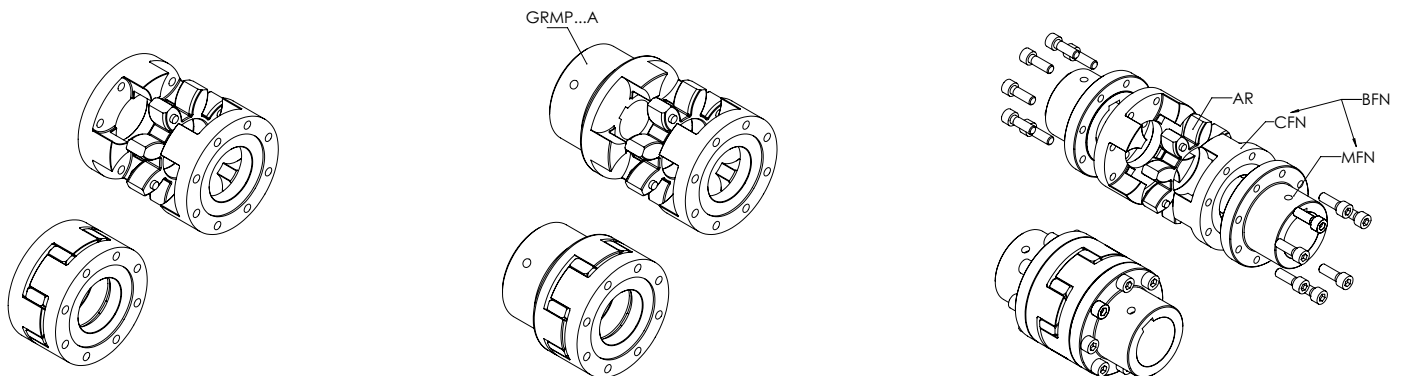

Hub **GRFBFN 48**

GRFBFN: shaft side flange “BFN” execution
GRFCFN: ring side flange “BFN” - “CFN” execution

Size

TRASCO® couplings “GRS” double cardanic series

This series allows compensation of high axial, radial and angular misalignments. The use of two snap rings also allows a high vibration damping effect resulting in a decrease in transmission noise and a reduction in wear of connected components (e.g., bearings). The intermediate element is made of aluminum and can be coupled with hubs of any design. By way of example only, the GRS element coupled with two GR hubs is shown.

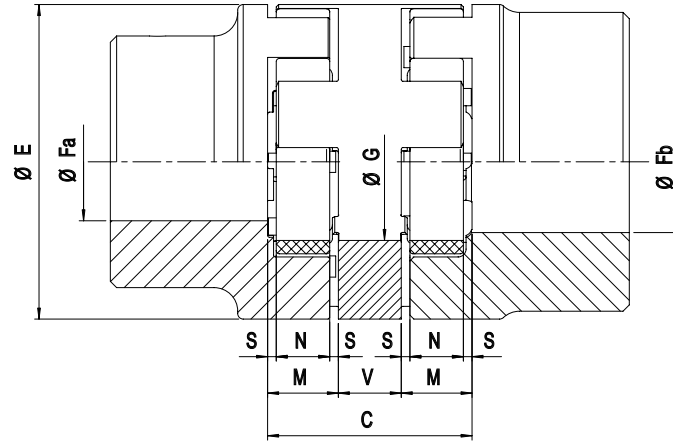

Size	Fa [mm]	Fb [mm]	V [mm]	C [mm]	M [mm]	S [mm]	N [mm]	E [mm]	G [mm]	ΔKr [mm]	ΔKw [°]
24/32	9 - 24	11 - 32	16	52	18	2	14	55	27	0,89	1°30'
28/38	9 - 28	11 - 38	18	58	20	2,5	15	65	30	1	
38/45	11 - 38	13 - 45	20	68	24	3	18	80	38	1,15	
42/55	11 - 42	13 - 55	22	74	26	3	20	95	46	1,26	
48/60	13 - 48	13 - 60	24	80	28	3,5	21	105	51	1,36	
55/70	16 - 55	16 - 70	28	88	30	4	22	120	60	1,52	
65/75	16 - 65	16 - 75	32	102	35	4,5	26	135	68	1,75	
75/90	16 - 75	16 - 90	36	116	40	5	30	160	80	2	
90/100	21 - 90	21 - 100	40	130	45	5,5	34	200	100	2,5	

Keyway according to DIN 6885 sheet 1 - JS9

Spacer element **GRS 48/60**

GRS: spacer element

Size

For hub “GR” order form please see TRASCO® GR base program

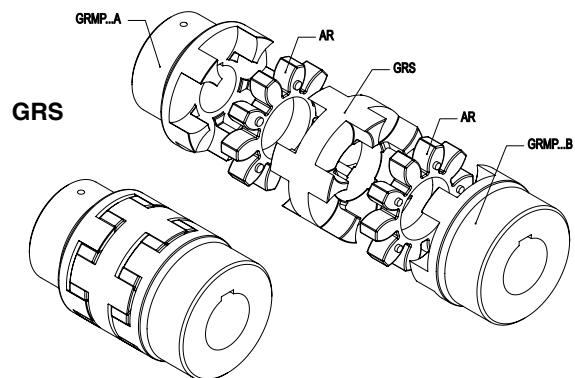

F _a	Bore of hub “A”	mm
F _b	Bore of hub “B”	mm
ΔK _r	Maximum radial misalignment	mm
ΔK _w	Maximum angular misalignment	°

TRASCO® couplings “GR FRT” drum brake series

The GR FRT series has been developed to suit drum brake (FRT) transmission according to DIN 15431/15435. It is considered an elastic coupling consisting of:

- Standard hub (any of TRASCO® family)
- Elastic spider
- Special hub attached to brake drum

Components are either made of cast-iron (G25), spheroidal cast-iron (GS400), or steel according to application. Also, assembling of different dimensioned brake drum to any kind of coupling is allowed. See below tables.

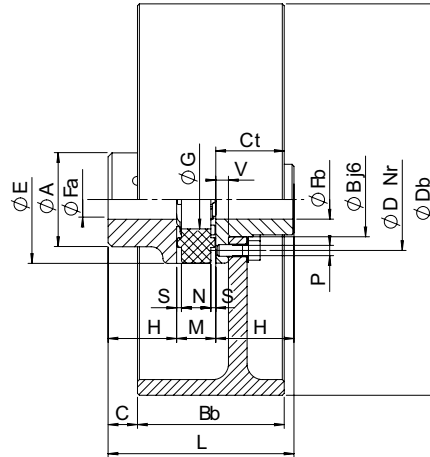

Keyway according to DIN 6885 sheet 1 - JS9

Db x Bb [mm]	Size											W _{FRT} [kg]	J _{FRT} [kg·m ²]	rpm with Vmax 30 m/s	
	28/38	38/45	42/55	48/60	55/70	65/75	75/90	90/100	100/110	110/125	125/145				
	GR FRT - drum brake - Ct [mm]														
160x60	30	31	-	-	-	-	-	-	-	-	-	-	2,12	0,01	3580
200x75	35	36	38	39	41	-	-	-	-	-	-	-	3,45	0,03	2860
250x95	43	44	46	47	49	50	52	-	-	-	-	-	6,87	0,08	2290
315x118	-	-	55	56	58	59	61	64	-	-	-	-	14,95	0,28	1820
400x150	-	-	68	69	71	72	74	77	79	82	-	-	31,20	0,89	1430
500x190	-	-	-	-	-	87	89	92	94	97	101	-	60,00	2,70	1150
630x236	-	-	-	-	-	-	107	110	112	115	119	-	112,00	8,01	910
710x265	-	-	-	-	-	-	-	-	-	123	126	130	161,00	14,90	810
800x300	-	-	-	-	-	-	-	-	-	-	-	144	202,00	27,20	720

Size	Fa; Fb min [mm]	Fa;Fb max [mm]				E [mm]	A [mm]	B [mm]	H [mm]	L [mm]	G [mm]	No. of screws	V [mm]	M [mm]	S [mm]	N [mm]	D [mm]	P [mm]
		Fa	Fb (GG25)	Fb (GS400)	Fb (Acciaio)													
28/38	10	28	20	22	24	65	48	38	35	90	30	8	6,5	20	2,5	15	52	M6
38/45	12	38	28	32	34	80	66	50	45	114	38	8	7,5	24	3	18	66	M8
42/55	14	42	30	38	42	95	75	60	50	126	46	12	9,5	26	3	20	80	M8
48/60	15	48	35	45	48	105	85	68	56	140	51	12	10,5	28	3,5	21	90	M8
55/70	20	55	42	50	55	120	98	78	65	160	60	8	12,5	30	4	22	102	M10
65/75	22	65	48	55	65	135	115	92	75	185	68	12	13,5	35	4,5	26	116	M10
75/90	30	75	58	70	75	160	135	106	85	210	80	15	15,5	40	5	30	136	M12
90/100	40	90	75	90	100	200	160	140	100	245	100	15	18,5	45	5,5	34	172	M16
100/110	45	115	-	100	-	225	180	156	110	270	113	15	20,5	50	6	38	195	M16
110/125	55	125	-	110	-	255	200	176	120	295	127	15	23,5	55	6,5	42	218	M20
125/145	55	145	-	130	-	290	230	204	140	340	147	15	27,5	60	7	46	252	M20

Hub **GRFRT 48/60**

GRFRT: brake side hub

Size

W _{FRT}	“GRFRT” weight	kg
J _{FRT}	“GRFRT” moment of inertia	kgm ²

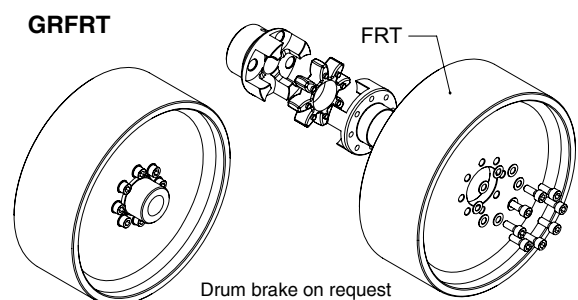

TRASCO® couplings “GR FRD” brake disc series

The GR FRD series has been developed to suit disc-brake (FRD) transmissions. It is considered an elastic coupling consisting of:

- Standard hub (any of TRASCO® family)
- Elastic spider
- Special hub attached to the brake disc

Components are either made of cast-iron (GG25), spheroidal cast-iron (GS400), or steel according to application. Also, assembling of different dimensioned brake discs to any kind of coupling is allowed. See below tables.

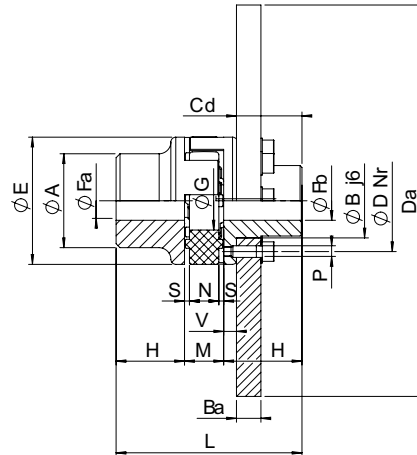

Keyway according to DIN 6885 sheet 1 - JS9

GR FRD - brake disc												W _{FRD} [kg]	J _{FRD} [kg m ²]	rpm with V _{max} 40 m/s
Da x Ba	28/38	38/45	42/55	48/60	55/70	65/75	75/90	90/100	100/110	110/125	125/145			
200x12,5	•	•	-	-	-	-	-	-	-	-	-	2,93	0,0154	3820
250x12,5	•	•	•	•	-	-	-	-	-	-	-	4,66	0,0376	3060
315x16	-	-	•	•	•	•	•	-	-	-	-	8,62	0,1118	2430
400x16	-	-	-	•	•	•	•	•	•	•	-	15,23	0,3152	1910
500x16	-	-	-	-	•	•	•	•	•	•	•	23,96	0,7680	1530
630x20	-	-	-	-	-	•	•	•	•	•	•	47,72	2,4264	1210
710x20	-	-	-	-	-	•	•	•	•	•	•	60,93	3,9151	1080
800x25	-	-	-	-	-	-	-	•	•	•	•	94,91	7,8790	950
900x25	-	-	-	-	-	-	-	-	-	•	•	118,95	12,6091	850

Size	Fa;Fb min [mm]	Fa;Fb max [mm]				E [mm]	A [mm]	B [mm]	H [mm]	L [mm]	G [mm]	No. of screws	V [mm]	M [mm]	S [mm]	N [mm]	D [mm]	Cd [mm]	P [mm]
		Fa	Fb (GG25)	Fb (GS400)	Fb (Steel)														
28/38	10	28	20	22	24	65	48	38	35	90	30	8	6,5	20	2,5	15	52	28,5	M6
38/45	12	38	28	32	34	80	66	50	45	114	38	8	7,5	24	3	18	66	37,5	M8
42/55	14	42	30	38	42	95	75	60	50	126	46	12	9,5	26	3	20	80	40,5	M8
48/60	15	48	35	45	48	105	85	68	56	140	51	12	10,5	28	3,5	21	90	45,5	M8
55/70	20	55	42	50	55	120	98	78	65	160	60	8	12,5	30	4	22	102	52,5	M10
65/75	22	65	48	55	65	135	115	92	75	185	68	12	13,5	35	4,5	26	116	61,5	M10
75/90	30	75	58	70	75	160	135	106	85	210	80	15	15,5	40	5	30	136	69,5	M12
90/100	40	90	75	90	100	200	160	140	100	245	100	15	18,5	45	5,5	34	172	81,5	M16
100/110	45	115	-	100	-	225	180	156	110	270	113	15	20,5	50	6	38	195	89,5	M16
110/125	55	125	-	110	-	255	200	176	120	295	127	15	23,5	55	6,5	42	218	96,5	M20
125/145	55	145	-	130	-	290	230	204	140	340	147	15	27,5	60	7	46	252	112,5	M20

Hub GRFRD 48/60

GRFRD: brake side hub

Size

W _{FRT}	“GRFRD” disc weight	kg
J _{FRT}	“GRFRD” moment of inertia	kgm ²

GRFRD

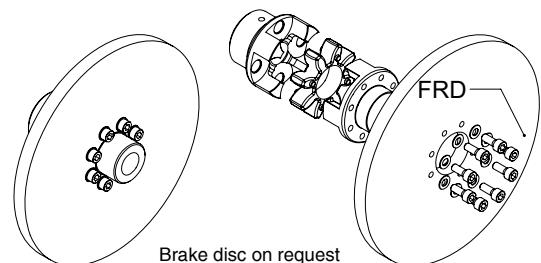

TRASCO® coupling weights and moments of inertia

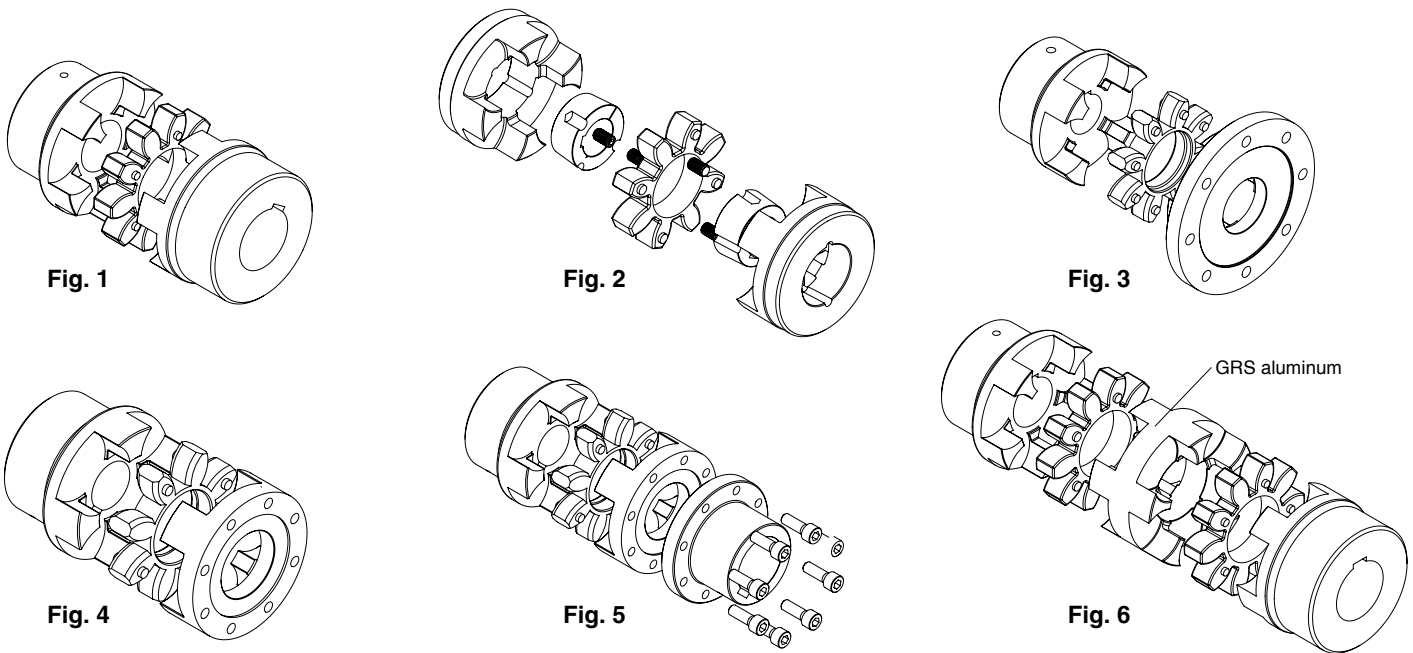

Size		GR execution A fig. 1	GR execution B fig. 1	GR execution AB fig. 1	GRALU execution A fig. 1	GRALU execution B fig. 1	GRALU execution AB fig. 1	GRB fig. 2	GRF (CF) fig. 3	GRF (CFN) fig. 4	GRF (BFN) fig. 5	Spacer element GRS fig. 6
19/24	W [kg]	-	0,37	-	-	0,14	-	-	0,23	-	-	-
	J [kgm ²]	-	0,0001	-	-	0,00004	-	-	0,00006	-	-	-
24/32	W [kg]	0,56	0,78	0,67	0,22	0,31	0,26	-	0,3	0,18	0,42	0,14
	J [kgm ²]	0,0002	0,0004	0,0003	0,00008	0,00015	0,00012	-	0,0003	0,00009	0,00018	0,00006
28/38	W [kg]	0,92	1,25	1,1	0,36	0,49	0,43	1	0,58	0,3	0,69	0,22
	J [kgm ²]	0,0005	0,0009	0,0007	0,0002	0,00034	0,00027	0,0007	0,0008	0,00021	0,00041	0,00013
38/45	W [kg]	1,97	2,5	2,25	0,77	0,98	0,9	1,7	0,8	0,313	0,933	0,35
	J [kgm ²]	0,0017	0,0027	0,002	0,0007	0,001	0,00084	0,0026	0,001	0,00047	0,00097	0,00035
42/55	W [kg]	3,1	3,85	3,46	-	1,5	-	2,8	1,41	0,76	1,81	0,51
	J [kgm ²]	0,0035	0,006	0,0047	-	0,002	-	0,0036	0,004	0,0012	0,0023	0,0007
48/60	W [kg]	4,2	5,3	4,75	-	2	-	4,7	1,62	0,89	2,27	0,67
	J [kgm ²]	0,006	0,01	0,008	-	0,004	-	0,0078	0,005	0,0017	0,0035	0,001
55/70	W [kg]	6,4	7,8	7,1	-	-	-	5	2,82	1,47	3,55	0,97
	J [kgm ²]	0,012	0,02	0,015	-	-	-	0,012	0,012	0,0035	0,007	0,002
65/75	W [kg]	9,7	11,8	10,8	-	-	-	6,9	3,46	1,89	4,89	1,43
	J [kgm ²]	0,024	0,035	0,03	-	-	-	0,014	0,017	0,0059	0,0123	0,004
75/90	W [kg]	15,2	20,8	18	-	-	-	14,8	5,03	3	7,86	2,2
	J [kgm ²]	0,051	0,082	0,07	-	-	-	0,065	0,032	0,0125	0,0275	0,009
90/100	W [kg]	26,2	30,2	28,2	-	-	-	35,4	7,9	4,87	13,54	3,9
	J [kgm ²]	0,13	0,17	0,15	-	-	-	0,162	0,073	0,033	0,108	0,025
100/110	W [kg]	32,6	-	-	-	-	-	-	13,5	7,55	20,15	-
	J [kgm ²]	0,22	-	-	-	-	-	-	0,139	0,063	0,14	-
110/125	W [kg]	45,5	-	-	-	-	-	-	18,8	10,15	27,05	-
	J [kgm ²]	0,38	-	-	-	-	-	-	0,255	0,11	0,242	-
125/145	W [kg]	68,8	-	-	-	-	-	-	27,4	14,9	40,9	-
	J [kgm ²]	0,76	-	-	-	-	-	-	0,463	0,21	0,48	-
140/160	W [kg]	93,0	-	-	-	-	-	-	-	-	-	-
	J [kgm ²]	1,30	-	-	-	-	-	-	-	-	-	-
160/185	W [kg]	137,0	-	-	-	-	-	-	-	-	-	-
	J [kgm ²]	2,46	-	-	-	-	-	-	-	-	-	-
180/200	W [kg]	197,0	-	-	-	-	-	-	-	-	-	-
	J [kgm ²]	4,40	-	-	-	-	-	-	-	-	-	-

Weight and moments of inertia are calculated on hubs with max diameter bore.

Tables for TRASCO® couplings with taper or splined bores

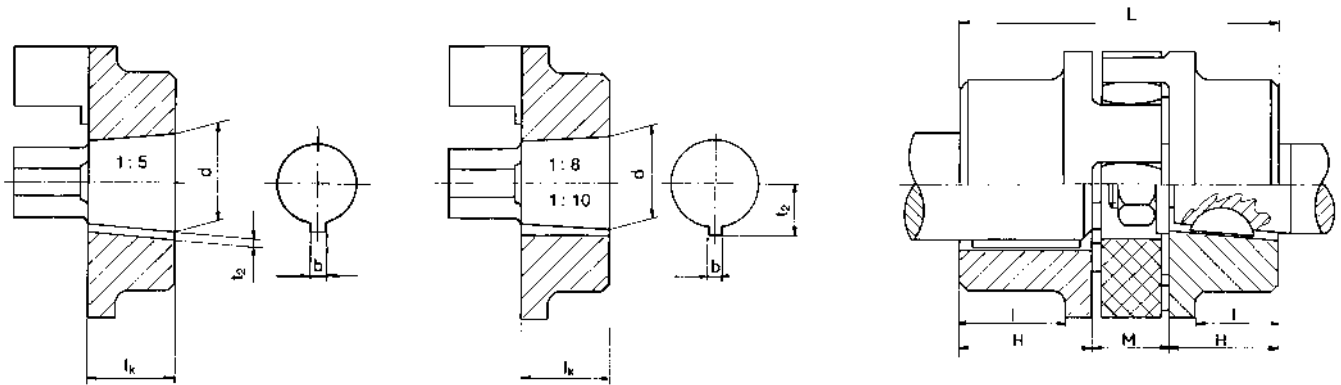

Taper 1:5 for: BOSCH - BUCHER- LEDUC - DÜSTERLOH

Code	$\varnothing d + 0,05$	b JS9	t2 + 0,1	lk
a1	9,85	2	1	11,5
a2	16,85	3	1,8	18,5
a3	19,85	4	2,2	21,5
a4	21,95	3	1,8	21,5
a5	24,85	5	2,9	26,5
a6	29,85	6	2,6	31,5
a7	34,85	6	2,6	36,5
a8	39,85	6	2,6	41,5

Taper 1:8 for: ATOS - CASAPPA - GARBE LAHMEYER - JOTTI & STROZZI - MARZOCCHI - SALAMI - SAUER-FLUID

Code	$\varnothing d + 0,05$	b + 0,05	t2 + 0,1	lk
b1	9,7	2,4	6	17
b2	11,6	3	7,1	16,5
b3	13	2,4	7,3	21
b4	14	3	8,5	17,5
b5	14,3	3,2	8,5	19,5
b6	17,287	3,2	9,6	24
b7	17,287	4	10,3	24
b8	17,287	3	9,7	24
b9	22,002	3,99	12,4	28
b10	25,463	4,78	15,1	36
b11	25,463	5	15,5	36
b12	27	4,78	15,3	32,5
b13	28,45	6	15,1	38,5
b14	33,176	6,38	18,8	44
b15	33,176	7	18,8	44
b16	43,057	7,95	3,378	51
b17	41,15	8	3,1	42,5

Taper 1:8 for: PARKER HANNIFIN NMF - TEVES

Code	$\varnothing d + 0,05$	b JS9	t2 + 0,1	lk
c1	19,95	5	12,1	32
c2	24,95	6	14,1	45
c3	29,75	8	17	50

SAE splined profile

Code	Size	Head	Pitch	N. of teeth	\angle
PH-S	5/8"	14,28	16/32	9	30°
PI-S	3/4"	17,46	16/32	11	30°
PB-S	7/8"	20,63	16/32	13	30°
PB-BS	1"	23,81	16/32	15	30°
PJ	1 1/8"	26,98	16/32	17	30°
PC-S	1 1/4"	29,63	dic-24	14	30°
PA-S	1 3/8"	33,33	16/32	21	30°
PD-S	1 1/2"	36,51	16/32	23	30°
PE-S	1 3/4"	42,86	16/32	27	30°
PF	2 9/16"	63,5	16/32	40	30°

DIN 5482

Code	Size	Head	Pitch	N. of teeth	Tolerance
P 8217	A 17 x 14	14,4	1,6	9	0,6
P 8228	A 28 x 25	26,25	1,75	15	0,302
P 8230	A 30 x 27	28	1,75	16	0,327
P 8235	A 35 x 31	31,5	1,75	18	0,676
P 8240	A 40 x 36	38	1,9	20	0,049
P 8245	A 45 x 41	44	2	22	0,181
P 8250	A 50 x 45	48	2	24	0,181

DIN 5480

Size	Head	Pitch	N. of teeth
20 x 1 x 18 x 7 H	18	1	18
20 x 1,25 x 14 x 7 H	17,5	1,25	14
25 x 1,25 x 18 x 7 H	22,5	1,25	18
30 x 2 x 13 x 7 H	26	2	13
30 x 2 x 14 x 7 H	26	2	14
35 x 2 x 16 x 7 H	32	2	16
40 x 2 x 18 x 7 H	36	2	18
45 x 2 x 21 x 7 H	41	2	21
48 x 2 x 22 x 9 H	44	2	22
50 x 2 x 24 x 7 H	48	2	24