

# BELTS DRIVE DESIGN V-BELTS-POLY-V TIMING BELTS



**PI BELT**

by  **PIZZIRANI**

**PI BELT** V-belt are built for excellent performance on a heavy-duty Z, A, B, C, D, E section industrial drivers. Power cables and compound are wrapped with a textile cover, and assure maximum protection against heat, oil, ozone.

**PI BELT** V-belt conventional cross-section are built with a UNISET technology, (limited and constant tolerance). Thanks to its precise dimensions, the belts correctly fits into the standard pulley grooves, and the extensive size range cover all applications in industrial and agricultural market.

**PI BELT** V-belt conventional cross-section are in line with ISO 4184, DIN 2215, RMA/MPTA IP-22 norms, and fits in pulley in line with ISO 4183, DIN 2211/1, RMA/MPTA IP-22 norms.

RoHS and Reach certified

### Construction:

- Polyester low-stretch cable
- Polychloroprene cover against heat, oil, ozone
- Durable orange marking indicating type and dimensions
- Dimensional stability: UNISET
- Temperature range: - 20 a + 70

### Nominal dimension:

SECTION	ISO 4184	RMA	Z	A	B	C	D	E
Back width		W (mm)	10	13	17	22	32	40
Primitive width		Wd (mm)	8,5	11	14	19	27	32
Height		T (mm)	6	8	11	14	20	25
Primitive length		Ld=Li+ (mm)	22	30	43	55	75	82
External length		Le=Li+ (mm)	38	50	66	85	126	157
Minim. Pulley diam.		d <sub>d</sub> (mm)	50	63	100	160	300	450
Weight		(Kg/m)	0,06	0,108	0,185	0,298	0,595	0,950
Maximum speed		v (m/s)	33					



**PI BELT** narrow V-belt are built for excellent performance on a heavy-duty SPZ, SPA, SPB, SPC, 3V, 5V, 8V section industrial drivers. Power cables and compound are wrapped with a textile cover, and assure maximum protection against heat, oil, ozone. **PI BELT** V-belt narrow section are built with a UNISSET technology, (limited and constant tolerance). Thanks to its precise dimensions, the belts correctly fits into the standard pulley grooves, and the extensive size range cover all applications in industrial and agricultural market. **PI BELT** V-belt narrow section increased transmission efficiency allows more compact and highly economical drive design, compared to the classical belts (until 40% more). **PI BELT** V-belt narrow section are in line with ISO 4184, BS 3790, DIN 7753/1, RMA/MPTA IP-22 norms, and fits in pulley in line with ISO 4183, DIN 2211/1, RMA/MPTA IP-22 norms.

RoHS and Reach certified

**Construction:**

- Polyester low-stretch cable
- Polychloroprene cover against heat, oil, ozone
- Durable orange marking indicating type and dimensions
- Dimensional stability : UNISSET
- Temperature range : - 20°C a + 70°C

**Nominal dimensions:**

SECTION	ISO 4184, BS 3790 DIN 7753/1 RMA/MPTA IP-22	SPZ	SPA	SPB	SPC	3V/9N	5V/15N	8V/25N
Back width	W (mm)	9,7	12,7	16,3	22	9	15	25
Primitive width	Wd (mm)	8,5	11	14	19			
Height	T (mm)	8	10	13	18	8	13	23
Primitive length	Ld=Le - (mm)					4	11	16
Internal length	Li=Ld - (mm)	37	45	60	83			
External length	Le=Ld + (mm)	13	18	22	30			
Minim. Pulley diam.	d <sub>i</sub> (mm)	63	90	140	224	63	140	315
Weight	(Kg/m)	0,065	0,115	0,200	0,350	0,070	0,185	0,520
Maximum speed	v (m/s)	42						



**PI BELT** cogged raw edge V-belt, last generation of V belts, are built for superior performance compared to the wrapped V belts . The raw edge construction put more power where high speeds, high speed ratio or small pulleys diameter are required, and increased transmission efficiency allows more compact and highly economical transmissions **PI BELT** raw edge V-belt in classical and narrow section are built with a UNISET technology, (limited and constant tolerance). Thanks to its precise dimensions, the belts correctly fits into the standard pulley grooves, and the extensive size range cover all applications in industrial and agricultural market. **PI BELT** raw edge V-belt are in line with ISO 4184, BS 3790, DIN 7753/1, RMA/MPTA IP-22 norms , and fits in pulley in line with ISO 4183, DIN 2211/1, RMA/MPTA IP-22 norms.

RoHS and Reach certified

**Construction:**

- Raw edge construction, ground
- Polyester low-stretch cable, and polychloroprene compound are vulcanised as one solid unit
- making the belt highly resistant to tensile and flexing forces
- Durable orange marking indicating type and dimensions
- Dimensional stability: UNISET
- Temperature range: - 25°C a + 80°C

**Nominal dimensions:**

SECTION	ISO 4184, BS 3790 DIN 7753/1 RMA/MPTA	SPZX	SPAX	SPBX	SPCX	3VX	5VX
Back width	W (mm)	9,7	12,7	16,3	22	9	15
Primitive width	Wd (mm)	8,5	11	14	19		
Height	T (mm)	8	10	13	18	8	13
Primitive length	Ld=Li + (mm)					4	11
Internal length	Li=Ld - (mm)	37	45	60	83		
External length	Le=Li + (mm)	51	63	82	113		
Minim. Pulley diam.	d <sub>d</sub> (mm)	56	71	112	180	56	112
Weight	(Kg/m)	0,060	0,110	0,185	0,330	0,060	0,183
Maximum speed	v (m/s)	48					

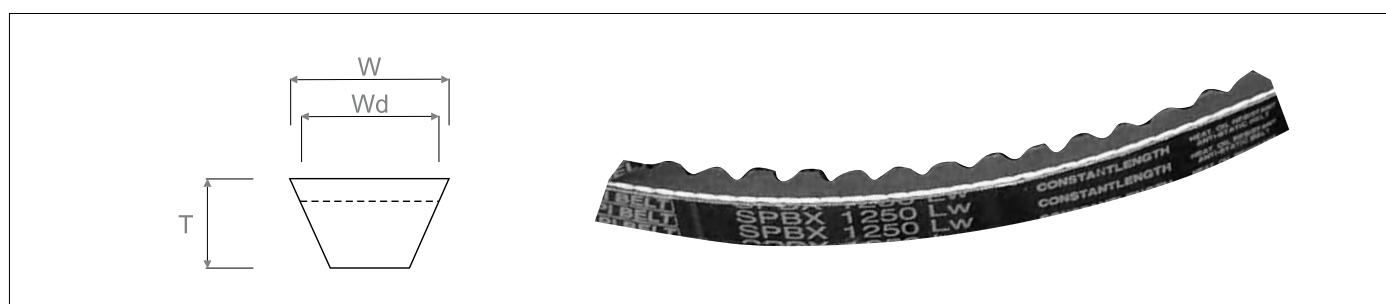

### BELT DRIVE DESIGN

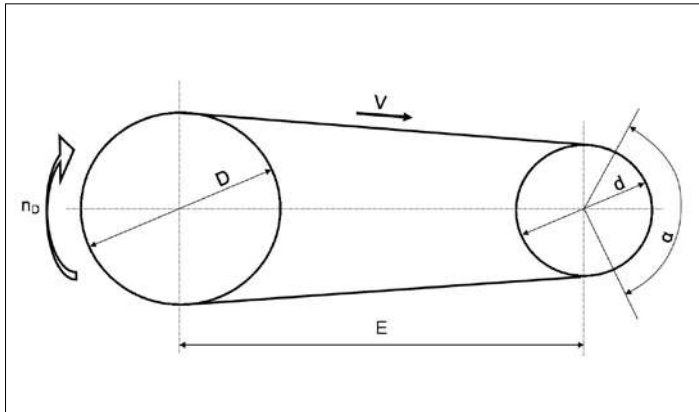

#### USEFUL DATA

D	Big pulley diameter	(mm)
$N_D$	Big pulley speed	(RPM)
d	Small pulley diameter	(mm)
$n_d$	Small pulley speed	(RPM)
V	Belt speed	(m/s)
E	Centre distance calculated	(mm)
$E'$	Centre distance required	(mm)
$L_{th}$	Theoretical belt length	(mm)
L	Belt datum length	(mm)
R	Speed ratio	
$p_{nom}$	Basic power	(kW)
S	Service factor	
$P_c$	Design power	(kW)
$P_o$	Basic power per belt	
$C_L$	Belt length correction factor	
$\alpha$	Arc of contact on small pulley	(degrees)
a	Arc of contact correction factor	
N	Number of belts required	

#### DATA DESIGN

Ratio :  $R = \frac{nd}{ND} = \frac{D}{d}$  always  $\geq 1$

• Speed ratio :  $V = \frac{nd \times d}{19100} = \frac{ND \times D}{19100}$

• Centre distance:  $0,7 (D + d) < E < 2 (D + d)$

- starting from L

$$E = \frac{L - 1,57(D + d)}{2} - \frac{(D - d)^2}{4[L - 1,57(D + d)]}$$

- easy formula, if  $R \leq 3$   $E = E' + \frac{L - L_{th}}{2}$

• Belt length  $L_{th} = 2E' + 1,57(D + d) + \frac{(D - d)^2}{4 E'}$

• Arc of contact correction factor (arc of contact on small pulley) : see table

• Belt length correction factor : see table for each section

• number of belts:  $N = \frac{P_{nom} \times S}{P_o \times a \times C_L} = \frac{P_c}{P_o \times a \times C_L}$

#### CHOICE OF BELT SIZE

- Find correct service factor S
- Find design power  $P_c = P_{nom} \times S$
- Select correct belt size related to design power  $P_c$  and to small pulley speed  $n_d$

#### CHOICE OF PULLEY DIAMETER

• Check speed ratio :  $R = \frac{nd}{ND}$  or  $R = \frac{D}{d}$

- Find pulley diameters , before d after D  
Find bigger pulley diameters to reduce groove numbers

Check speed belt , in order not exceed max value :  $v = \frac{nd \times d}{19100} = \frac{ND \times D}{19100}$

#### CHOICE OF BELTS LENGTH

- Check theoretical belt length  $L_{th}$ :

$$L_{th} = 2E' + 1,57(D + d) + \frac{(D - d)^2}{4 E'}$$

- Check standard belt length L closest to the theoretical belt length

- Find exact centre distance:

$$E = \frac{L - 1,57(D + d)}{2} - \frac{(D - d)^2}{4[L - 1,57(D + d)]}$$

or with easy formula :  $E = E' + \frac{L - L_{th}}{2}$

#### CALCULATION OF NUMBER OF BELTS REQUIRED

- Find basic power per belt  $P_o$  related to d, R and  $n_d$  for  $\alpha = 180^\circ$

- Find the arc of contact correction factor related to  $\frac{D - d}{E}$

- Find belt length correction factor  $C_L$

- Check belts number :

$$N = \frac{P \times S}{P_o \times a \times C_L} = \frac{P_c}{P_o \times a \times C_L}$$

## TENSION CALCULATION

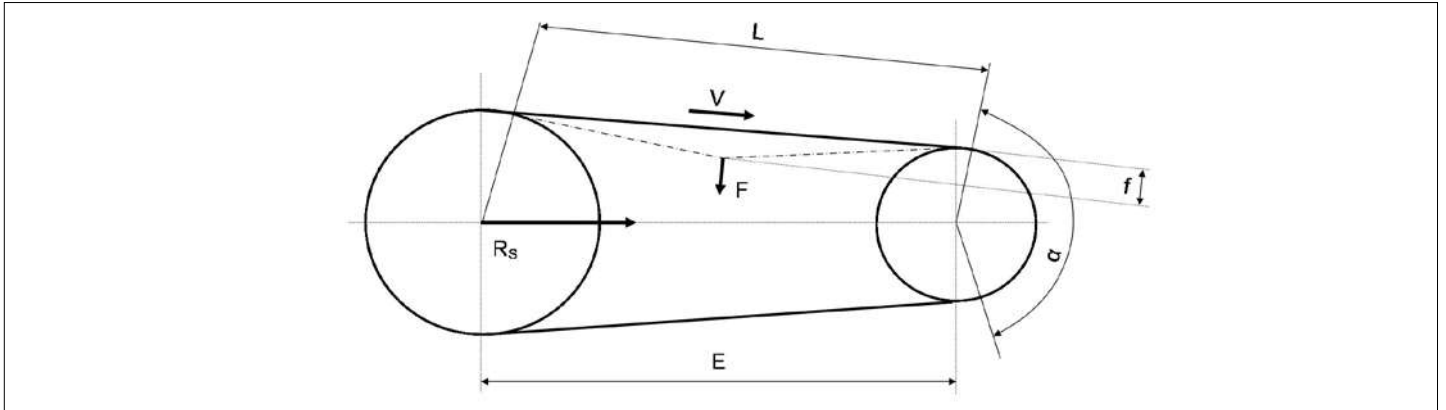

### USEFUL DATA

T	Belt effective tension	daN	L	Span length	mm
a	Arc of contact correction factor		E	Centre distance	mm
P <sub>nom</sub>	Nominal Power	kW	f	Deflection	mm
P <sub>c</sub>	Calculation Power	kW	F	Deflection force	daN
N	Number of belts		R <sub>s</sub>	Static reaction on the shaft	daN
V	Linear speed	m/s	α	Arc of contact on small pulley	
k	Belt mass unit				

### BELT MASS UNIT K

SPZ	0,007	XPZ	0,007	Z	0,006
SPA	0,012	XPA	0,012	A	0,011
SPB	0,019	XPB	0,019	B	0,019
SPC	0,038	XPC	0,036	C	0,031
				D	0,059

### FIND THE REQUIRED STATIC TENSION PER BELT

$$T = \frac{50(2,5 - a) P_{nom}}{aNV} + kV^2 \quad a: \text{function of } \frac{D-d}{E} \text{ and arc of contact } \alpha \quad k: \text{see table}$$

### FIND SPAN LENGTH

$$L = E \left[ 1 - \frac{1}{8} \left( \frac{D-d}{E} \right)^2 \right]$$

### DEFLECTION DATA

$$f = \frac{L}{100}$$

### DETERMINE DEFLECTION FORCE FOR DEFLECTION DATA = 1% SPAN LENGTH

$$F = \frac{T}{25}$$

### FIND STATIC REACTION ON THE SHAFT

$$R_s = 2NT \cos \beta \quad \beta = 90 - \frac{\alpha}{2} \quad \alpha = \frac{D-d}{E} \quad \text{see table arc of contact factor}$$

## SAFETY FACTORS

A proper choice of the safety factor ensures the operation of the V-belts. The following table lists the most common working machinery with safety coefficients recommended

**Table 2 : Value of safety factor**

	-AC electric motors a low starting "			-AC electric motors a medium starting "		
	- CC electric motors a low starting "			-CC electric motors a low starting "		
	-Internal combustion engines with 4 or more cylinders			-Internal combustion engines with 4 or more cylinders		
	-Water and steam turbines			-Water and steam turbines		
	Daily Service			Daily Service		
	Up to 8hrs	8/16 hrs	16/24hrs	Up to 8hrs	8/16 hrs	16/24hrs
Centrifugal pumps up to 7,5 Kw Blowers and exhausters Compressors Light-duty conveyors Fans up to 7,5 Kw	1,0	1,1	1,2	1,1	1,2	1,3
Pumps over 7,5 Kw Revolving and vibrating screens Dough mixers Rotary compressors Medium -duty conveyors Fans over to 7,5 Kw Generators Printing machinery Machine tools	1,1	1,2	1,3	1,2	1,3	1,4
Piston pumps Brick machinery Paper mill beaters Saw mill and woodworking Bucket elevators Hammer mills Exciters Conveyors ( drag-pan-screw ) Piston compressors	1,2	1,3	1,4	1,4	1,5	1,6
Crusher (gyratory-jaw-roll ) Mills ( ball-rod-tube) Rubber extruders -calenders	1,3	1,4	1,5	1,5	1,6	1,8

## ARC CORRECTION FACTOR

$\frac{D-d}{E}$	Correction factor	Angle small pulley
0,00	1	180°
0,05	0,99	177°
0,10	0,99	174°
0,15	0,98	171°
0,20	0,97	169°
0,25	0,97	166°
0,30	0,96	163°
0,35	0,95	160°
0,40	0,94	157°
0,45	0,93	154°
0,50	0,93	151°
0,55	0,92	148°
0,60	0,91	145°
0,65	0,90	142°
0,70	0,89	139°
0,75	0,88	136°
0,80	0,87	133°
0,85	0,86	130°
0,90	0,85	127°
0,95	0,83	123°
1,00	0,82	120°
1,05	0,81	117°
1,10	0,80	113°
1,15	0,78	110°
1,20	0,77	106°
1,25	0,75	103°
1,30	0,73	99°
1,35	0,72	95°
1,40	0,70	91°
1,45	0,68	87°

D = Big pulley diameter

d = Small pulley diameter

E = Centre distance

## LENGTH CORRECTION FACTOR $C_L$

Section	Length mm											
	600-800	800-950	1000-1250	1250-1700	1700-2350	2350-3150	3150-4000	4000-5000	5000-6000	6000-7000	7000-9000	9000-12500
Z	0,9	0,95	1	1,05	1,12							
A		0,8	0,85	0,9	0,95	1	1,05					
B			0,8	0,85	0,9	0,95	1	1,05				
C					0,8	0,85	0,9	0,95	1	1,02	1,05	1,1
D					0,8	0,85	0,9	0,95	1	1,02	1,05	1,1
SPZ	0,8	0,85	0,9	0,95	1	1,08	1,12					
SPA		0,8	0,85	0,9	0,95	1	1,05					
SPB			0,8	0,85	0,9	0,95	1	1,05				
SPC					0,8	0,85	0,9	0,95	1	1,02	1,05	1,1
XPZ	0,8	0,85	0,9	0,95	1	1,08	1,12					
XPA		0,8	0,85	0,9	0,95	1	1,05					
XPB				0,9	0,95	1	1,05					
XPC					0,9	0,95	0,98	1				





### SECTION SPZ/3V

RPM small pulley	BASIC POWER IN KW SMALL PULLEY DIAMETER															Belt speed m/s	RPM	Additional power (Kw) for speed ratio				
	63	67	71	75	80	85	90	95	100	106	112	118	125	132	140			1,01 to 1,05	1,06 to 1,26	1,27 to 1,57	1,58 to 3,38	over 3,39
	100	0,10	0,12	0,13	0,15	0,16	0,18	0,20	0,22	0,24	0,26	0,28	0,30	0,32	0,35			0,38	100	0,00	0,01	0,01
200	0,18	0,21	0,24	0,27	0,30	0,34	0,37	0,40	0,44	0,48	0,52	0,56	0,60	0,65	0,70	200	0,00	0,02	0,02	0,03	0,03	
300	0,26	0,30	0,34	0,38	0,43	0,48	0,53	0,58	0,63	0,68	0,74	0,80	0,87	0,94	1,01	300	0,00	0,03	0,04	0,05	0,05	
400	0,33	0,38	0,43	0,48	0,55	0,61	0,68	0,74	0,81	0,88	0,96	1,03	1,12	1,21	1,31	400	0,01	0,03	0,05	0,06	0,06	
500	0,39	0,45	0,52	0,58	0,66	0,74	0,82	0,90	0,98	1,07	1,17	1,26	1,37	1,47	1,60	500	0,01	0,04	0,06	0,08	0,08	
600	0,45	0,53	0,60	0,68	0,77	0,87	0,96	1,05	1,15	1,26	1,37	1,48	1,61	1,73	1,88	10	600	0,01	0,05	0,07	0,09	0,10
700	0,51	0,60	0,68	0,77	0,88	0,99	1,10	1,20	1,31	1,44	1,57	1,69	1,84	1,98	2,15		700	0,01	0,06	0,09	0,11	0,11
720	0,52	0,61	0,70	0,79	0,90	1,01	1,12	1,23	1,34	1,47	1,60	1,73	1,88	2,03	2,20		720	0,01	0,06	0,09	0,11	0,12
800	0,56	0,66	0,76	0,86	0,99	1,11	1,23	1,35	1,47	1,62	1,76	1,90	2,07	2,23	2,42		800	0,01	0,07	0,10	0,12	0,13
900	0,62	0,73	0,84	0,95	1,09	1,22	1,36	1,49	1,63	1,79	1,95	2,11	2,29	2,47	2,68		900	0,01	0,08	0,11	0,14	0,14
960	0,65	0,77	0,88	1,00	1,15	1,29	1,44	1,58	1,72	1,89	2,06	2,23	2,42	2,62	2,84	20	960	0,01	0,08	0,12	0,15	0,15
1000	0,67	0,79	0,91	1,04	1,19	1,34	1,49	1,63	1,78	1,96	2,13	2,31	2,51	2,71	2,94		1000	0,01	0,09	0,12	0,15	0,16
1100	0,72	0,85	0,99	1,12	1,28	1,45	1,61	1,77	1,93	2,12	2,32	2,50	2,72	2,94	3,19		1100	0,01	0,10	0,14	0,17	0,18
1200	0,77	0,91	1,06	1,20	1,38	1,56	1,73	1,91	2,08	2,29	2,49	2,70	2,94	3,17	3,44		1200	0,02	0,10	0,15	0,18	0,19
1300	0,82	0,97	1,13	1,28	1,47	1,66	1,85	2,04	2,23	2,45	2,67	2,89	3,14	3,40	3,68		1300	0,02	0,11	0,16	0,20	0,21
1400	0,86	1,03	1,19	1,36	1,56	1,77	1,97	2,17	2,37	2,61	2,84	3,08	3,35	3,62	3,92	30	1400	0,02	0,12	0,17	0,21	0,23
1440	0,88	1,05	1,22	1,39	1,60	1,81	2,01	2,22	2,42	2,67	2,91	3,15	3,43	3,71	4,02		1440	0,02	0,13	0,18	0,22	0,23
1500	0,91	1,08	1,26	1,43	1,65	1,87	2,08	2,30	2,51	2,76	3,01	3,26	3,55	3,83	4,16		1500	0,02	0,13	0,19	0,23	0,24
1600	0,95	1,14	1,32	1,51	1,74	1,97	2,20	2,42	2,65	2,91	3,18	3,44	3,75	4,05	4,39		1600	0,02	0,14	0,20	0,24	0,26
1700	0,99	1,19	1,39	1,58	1,83	2,07	2,31	2,55	2,78	3,06	3,34	3,62	3,94	4,26	4,62		1700	0,02	0,15	0,21	0,26	0,27
1800	1,03	1,24	1,45	1,66	1,91	2,17	2,42	2,67	2,92	3,21	3,50	3,80	4,13	4,46	4,84	30	1800	0,02	0,16	0,22	0,27	0,29
1900	1,07	1,29	1,51	1,73	1,99	2,26	2,52	2,79	3,05	3,36	3,66	3,97	4,32	4,67	5,06		1900	0,03	0,17	0,24	0,29	0,31
2000	1,11	1,34	1,57	1,80	2,08	2,35	2,63	2,90	3,18	3,50	3,82	4,14	4,50	4,86	5,27		2000	0,03	0,17	0,25	0,30	0,32
2100	1,15	1,39	1,63	1,86	2,16	2,45	2,73	3,02	3,30	3,64	3,97	4,30	4,68	5,06	5,48		2100	0,03	0,18	0,26	0,32	0,34
2200	1,19	1,44	1,68	1,93	2,24	2,54	2,84	3,13	3,43	3,78	4,12	4,47	4,86	5,25	5,69		2200	0,03	0,19	0,27	0,33	0,35
2300	1,22	1,48	1,74	2,00	2,31	2,63	2,94	3,25	3,55	3,91	4,27	4,63	5,03	5,44	5,89	30	2300	0,03	0,20	0,29	0,35	0,37
2400	1,26	1,53	1,80	2,06	2,39	2,71	3,04	3,36	3,67	4,05	4,42	4,78	5,20	5,62	6,09		2400	0,03	0,21	0,30	0,36	0,39
2500	1,29	1,57	1,85	2,12	2,46	2,80	3,13	3,46	3,79	4,18	4,56	4,94	5,37	5,80	6,28		2500	0,03	0,22	0,31	0,38	0,40
2600	1,33	1,62	1,90	2,19	2,54	2,88	3,23	3,57	3,91	4,31	4,70	5,09	5,54	5,97	6,47		2600	0,04	0,23	0,32	0,40	0,42
2700	1,36	1,66	1,95	2,25	2,61	2,97	3,32	3,67	4,02	4,43	4,84	5,24	5,69	6,15	6,65		2700	0,04	0,24	0,33	0,41	0,43
2800	1,39	1,70	2,00	2,31	2,68	3,05	3,41	3,78	4,13	4,55	4,97	5,38	5,85	6,31	6,83	30	2800	0,04	0,24	0,35	0,43	0,45
2880	1,42	1,73	2,04	2,35	2,73	3,11	3,49	3,86	4,22	4,65	5,08	5,49	5,97	6,44	6,97		2880	0,04	0,25	0,36	0,44	0,45
2900	1,42	1,74	2,05	2,36	2,75	3,13	3,50	3,88	4,24	4,68	5,10	5,52	6,00	6,48	7,00		2900	0,04	0,25	0,36	0,44	0,47
3000	1,45	1,78	2,10	2,42	2,82	3,21	3,59	3,97	4,35	4,79	5,23	5,66	6,15	6,63	7,17		3000	0,04	0,26	0,37	0,46	0,48
3100	1,48	1,82	2,15	2,48	2,88	3,28	3,68	4,07	4,45	4,91	5,36	5,80	6,30	6,79	7,33		3100	0,04	0,27	0,38	0,47	0,50
3200	1,51	1,85	2,19	2,53	2,95	3,36	3,76	4,16	4,56	5,02	5,48	5,93	6,44	6,94	7,49	30	3200	0,04	0,28	0,40	0,49	0,51
3300	1,54	1,89	2,24	2,58	3,01	3,43	3,85	4,26	4,66	5,13	5,60	6,06	6,58	7,08	7,65		3300	0,04	0,29	0,41	0,50	0,53
3400	1,56	1,92	2,28	2,64	3,07	3,50	3,93	4,35	4,76	5,24	5,72	6,18	6,71	7,23	7,80		3400	0,05	0,30	0,42	0,52	0,55
3500	1,59	1,96	2,32	2,69	3,13	3,57	4,01	4,43	4,85	5,35	5,83	6,30	6,84	7,36	7,94		3500	0,05	0,31	0,43	0,53	0,56

Basic power for theoretical 25.000 hrs belt life .



## SECTION SPB/5V

RPM small pulley	BASIC POWER IN KW SMALL PULLEY DIAMETER											VBelt speed m/s	Additional Power (Kw) for speed ratio					
	160	170	180	190	200	212	224	236	250	280	315		RPM	1,01 to 1,05	1,06 to 1,26	1,27 to 1,57	1,58 to 3,38	over 3,39
	100	0,84	0,93	1,02	1,12	1,21	1,32	1,43	1,45	1,66	1,94		2,25	10	100	0,01	0,04	0,07
200	1,53	1,71	1,89	2,06	2,24	2,45	2,66	2,86	3,10	3,62	4,21	200	0,01		0,09	0,13	0,16	0,17
300	2,17	2,43	2,69	2,94	3,20	3,50	3,81	4,11	4,46	5,20	6,06	300	0,02		0,14	0,20	0,24	0,25
400	2,77	3,11	3,45	3,78	4,11	4,51	4,90	5,29	5,57	6,72	7,83	400	0,03		0,19	0,26	0,32	0,34
500	3,35	3,76	4,17	4,58	4,99	5,47	5,96	6,44	6,99	8,18	9,53	500	0,04		0,23	0,33	0,40	0,43
600	3,90	4,39	4,87	5,36	5,83	6,41	6,97	7,54	8,19	9,58	11,17	20	600	0,04	0,28	0,40	0,48	0,51
700	4,43	4,99	5,55	6,10	6,65	7,31	7,96	8,61	9,36	10,94	12,75		700	0,05	0,33	0,46	0,57	0,59
720	4,54	5,11	5,68	6,25	6,81	7,49	8,15	8,82	9,58	11,21	13,06		720	0,05	0,33	0,53	0,59	0,62
800	4,95	5,58	6,20	6,83	7,45	8,18	8,91	9,64	10,48	12,26	14,28		800	0,06	0,37	0,53	0,65	0,69
900	5,44	6,14	6,84	7,53	8,21	9,03	9,84	10,64	11,57	13,53	15,74		900	0,07	0,42	0,60	0,72	0,77
960	5,73	6,47	7,21	7,94	8,66	9,52	10,38	11,23	12,20	14,26	16,60		960	0,07	0,44	0,62	0,77	0,81
1000	5,92	6,69	7,45	8,21	8,96	9,85	10,73	11,61	12,62	14,75	17,15		1000	0,07	0,46	0,66	0,81	0,86
1100	6,39	7,22	8,05	8,87	9,68	10,64	11,60	12,54	13,63	15,92	18,50		1100	0,08	0,51	0,72	0,89	0,94
1200	6,83	7,73	8,62	9,50	10,38	11,41	12,44	13,45	14,61	17,05	19,70		1200	0,09	0,56	0,79	0,97	1,03
1300	7,27	8,23	9,18	10,12	11,05	12,15	13,24	14,32	15,55	18,13	20,99		1300	0,09	0,60	0,86	1,05	1,11
1400	7,69	8,71	9,72	10,71	11,70	12,87	14,02	15,15	16,45	19,15	22,14	30	1400	0,10	0,65	0,93	1,13	1,20
1440	7,85	8,89	9,93	10,95	11,95	13,15	14,32	15,48	16,80	19,55	22,57		1440	0,10	0,66	0,94	1,15	1,21
1500	8,09	9,17	10,24	11,29	12,33	13,56	14,76	15,95	17,31	20,12	23,21		1500	0,10	0,69	0,99	1,21	1,28
1600	8,48	9,62	10,74	11,84	12,93	14,22	15,48	16,72	18,13	21,04	24,21		1600	0,11	0,75	1,05	1,29	1,37
1700	8,85	10,04	11,22	12,37	13,51	14,85	16,16	17,44	18,90	21,90	25,12		1700	0,12	0,79	1,12	1,37	1,45
1800	9,21	10,45	11,68	12,88	14,06	15,45	16,81	18,13	19,64	22,70	25,96		1800	0,13	0,84	1,19	1,45	1,54
1900	9,56	10,85	12,12	13,36	14,58	16,02	17,42	18,78	20,32	23,44			1900	0,13	0,88	1,25	1,54	1,63
2000	9,88	11,22	12,54	13,82	15,08	16,56	17,99	19,39	20,96	24,11		2000	0,14	0,93	1,32	1,62	1,71	
2100	10,19	11,58	12,93	14,26	15,55	17,07	18,53	19,95	21,54			2100	0,15	0,98	1,39	1,69	1,79	
2200	10,49	11,92	13,31	14,67	16,00	17,54	19,04	20,47	22,08			2200	0,16	1,02	1,45	1,78	1,88	
2300	10,77	12,23	13,66	15,06	16,41	17,98	19,50	20,95				2300	0,16	1,07	1,51	1,86	1,97	
2400	11,03	12,53	14,00	15,42	16,79	18,39	19,92	21,38				2400	0,17	1,11	1,58	1,94	2,05	
2500	11,27	12,81	14,30	15,75	17,15	18,76	20,30					2500	0,18	1,16	1,65	2,02	2,14	
2600	11,50	13,07	14,59	16,06	17,47	19,09						2600	0,19	1,21	1,72	2,10	2,22	
2700	11,71	13,31	14,85	16,33	17,76	19,39						2700	0,19	1,25	1,78	2,18	2,31	
2800	11,90	13,52	15,08	16,58	18,01							2800	0,20	1,29	1,84	2,26	2,39	
2880	12,04	13,68	15,25	16,76								2880	0,20	1,32	1,88	2,31	2,44	
2900	12,07	13,71	15,29	16,80								2900	0,21	1,34	1,91	2,34	2,48	
3000	12,22	13,89	15,47	16,99								3000	0,22	1,39	1,98	2,42	2,57	

Basic power for theoretical 25.000 hrs belt life

## SECTION SPC

RPM small pulley	BASIC POWER IN KW SMALL PULLEY DIAMETER																Vbel speed m/s	Additional power (Kw) for speed ratio						
	224	236	250	265	280	300	315	335	355	375	400	425	450	475	500	530		560	RPM	1,01 to 1,05	1,06 to 1,26	1,27 to 1,57	1,58 to 3,38	over 3,39
100	1,99	2,20	2,45	2,72	2,99	3,34	3,60	3,96	4,31	4,65	5,09	5,52	5,95	6,38	6,80	7,31	7,82	10	100	0,02	0,14	0,20	0,25	0,26
200	3,59	4,00	4,48	4,99	5,49	6,17	6,67	7,33	8,00	8,66	9,48	10,30	11,11	11,92	12,72	13,68	14,64	20	200	0,04	0,29	0,41	0,50	0,53
300	5,04	5,64	6,33	7,07	7,81	8,78	9,51	10,48	11,44	12,39	13,58	147,76	15,93	17,10	18,26	19,64	21,01	30	300	0,07	0,43	0,61	0,75	0,79
400	6,40	7,17	8,07	9,04	9,99	11,26	12,20	13,45	14,70	15,93	17,47	18,99	20,50	22,00	23,48	25,25	27,00	40	400	0,09	0,57	0,81	1,00	1,06
500	7,67	8,62	9,72	10,90	12,06	13,61	14,76	16,28	17,80	19,30	21,16	23,00	24,82	26,63	28,42	30,54	32,64	50	500	0,11	0,72	1,02	1,25	1,32
600	8,87	9,99	11,28	12,66	14,04	15,85	17,20	18,98	20,75	22,50	24,67	26,80	28,92	31,00	33,06	35,50	67,89	60	600	0,13	0,86	1,22	1,50	1,59
700	10,00	11,29	12,77	14,35	15,92	17,98	19,52	21,55	23,56	25,54	27,99	30,40	32,77	35,11	37,40	40,11	42,75	70	700	0,15	1	1,43	1,75	1,85
720	10,22	11,54	13,06	14,68	16,28	18,40	19,97	22,05	24,10	26,13	28,63	31,09	33,51	35,89	38,23	40,99	43,67	80	720	0,16	1,03	1,46	1,80	1,90
800	11,08	12,52	14,19	15,95	17,71	20,02	21,73	23,99	26,22	28,42	31,12	33,77	36,37	38,93	41,42	44,34	47,18	90	800	0,17	1,15	1,63	2,00	2,11
900	12,10	13,69	15,53	17,48	19,41	21,95	23,82	26,30	28,73	31,12	34,05	36,92	39,71	42,44	45,09	48,18	51,15	100	900	0,2	1,29	1,85	2,25	2,38
960	12,68	14,36	16,30	18,35	20,38	23,05	25,02	27,61	30,16	32,66	35,71	38,69	41,58	44,39	47,12	50,27	53,29	110	960	0,21	1,37	1,95	2,40	2,54
1000	13,06	14,79	16,80	18,92	21,02	23,77	25,80	28,47	31,08	33,64	36,77	39,82	42,77	45,63	48,39	51,58	54,61	120	1000	0,22	1,43	2,04	2,50	2,64
1100	13,96	15,83	18,00	20,28	22,53	25,48	27,65	30,49	33,27	35,98	39,27	42,46	45,52	48,47	51,29	53,00	56,83	130	1100	0,24	1,57	2,24	2,75	2,91
1200	14,81	16,81	19,12	21,55	23,95	27,08	29,38	32,37	35,29	38,12	41,54	44,82	47,96	50,94	52,51	55,00	57,58	140	1200	0,26	1,72	2,44	3,00	3,17
1300	15,89	17,72	20,17	22,74	25,27	28,56	30,97	34,09	37,12	40,05	43,56	46,90	49,90	52,86	55,00	56,85	58,74	150	1300	0,28	1,86	2,65	3,25	3,44
1400	16,31	18,56	21,14	23,84	26,48	29,92	32,42	35,65	38,77	41,76	45,32	47,34	51,03	53,09	55,65	57,44	59,45	160	1400	0,31	2	2,85	3,50	3,70
1440	16,59	18,88	21,50	24,25	26,94	30,43	32,96	36,23	39,37	42,38	45,77	47,81	51,54	53,62	56,21	58,01	60,04	170	1440	0,31	2,06	2,93	3,50	3,81
1500	16,98	19,33	22,02	24,84	27,59	31,15	33,73	37,04	40,22	43,24	46,05	48,10	51,85	53,94	56,54	57,00	60,40	180	1500	0,33	2,15	3,05	3,75	3,96
1600	17,58	20,03	22,83	25,75	28,59	32,24	34,88	38,25	41,45	44,08	46,70	48,84	52,20	54,10	56,00			190	1600	0,35	2,29	3,26	4,00	4,23
1700	18,11	20,65	23,55	26,56	29,47	33,20	35,88	39,27	42,07	44,39	47,33	49,46	52,87					200	1700	0,37	2,43	3,46	4,25	4,49
1800	18,57	21,20	24,18	27,26	30,23	34,01	36,71	40,06	42,78	44,89	48,47	50,65	53,45					40	1800	0,39	2,58	3,66	4,50	4,76
1900	18,97	21,67	24,71	27,85	30,87	34,67	37,04	40,48	43,00	45,06	48,89							40	1900	0,42	2,72	3,87	4,75	5,02
2000	19,29	22,05	25,15	28,34	31,37	35,55	37,95	40,81	43,33	45,98	47,65							40	2000	0,44	2,86	4,07	5,00	5,29

Basic power for theoretical 25.000 hrs belt life

## SECTION 8V

RPM small pulley	BASIC POWER IN KW SMALL PULLEY DIAMETER														VBelt speed m/s	Additional power (Kw) for speed ratio					
	315	335	355	375	400	425	450	475	500	530	560	600	670	750		RPM	1,01 to 1,05	1,06 to 1,26	1,27 to 1,57	1,58 to 3,38	over 3,39
100	4,21	4,63	5,04	5,44	5,96	6,46	6,96	7,46	7,96	8,55	9,15	11,00	13,00	14,80	10	100					
200	7,80	8,58	9,36	10,13	11,09	12,05	13,00	13,95	14,88	16,01	17,13	20,00	23,50	27,00		200	0,08	0,3	0,67	0,88	0,94
300	11,13	12,26	13,38	14,50	15,89	172,88	18,64	20,01	21,36	22,98	24,58	30,00	34,20	38,30		300					
400	14,27	15,74	17,20	18,64	20,44	22,22	23,99	25,74	27,47	29,54	31,59	34,70	42,10	49,00	20	400	0,14	0,6	1,40	1,70	1,90
500	17,27	19,05	20,83	22,58	24,76	26,91	29,04	31,16	33,25	35,73	38,19	43,50	51,00	58,40		500					
600	20,12	22,21	24,28	26,33	28,86	31,36	33,84	36,27	38,68	41,54	45,70	51,80	59,60	67,80	30	600	0,26	1	1,80	2,60	2,70
700	22,84	25,21	27,57	29,88	32,75	35,57	38,34	41,08	43,76	46,93	50,02	55,00	65,90	73,70		700					
720	23,36	25,80	28,20	30,57	33,50	36,38	39,21	41,99	44,73	47,96	51,09	56,40	67,10	75,00		720	0,28	1,6	2,40	3,20	3,40
800	25,42	28,07	30,68	33,25	36,41	39,51	42,55	45,55	48,46	51,88	55,20	61,30	72,00	79,80	35	800					
900	27,87	30,77	33,61	36,41	39,84	43,20	46,46	49,65	52,76	56,37	59,85	67,20	76,30	89,10		900					
960	29,27	32,30	35,29	38,21	41,78	45,27	48,65	51,94	55,13	58,82	62,35	69,30	78,20	86,80	40	960	0,31	2	2,85	3,90	4,10
1000	30,19	33,31	36,36	39,36	43,02	46,59	50,04	53,39	56,62	60,35	63,89	71,00	79,60	88,00		1000					
1100	30,80	35,67	38,93	42,10	45,95	49,68	53,26	56,71	60,01	65,40	69,00	74,00	82,20			1100					
1200	31,70	37,87	41,29	44,60	48,60	52,44	56,11	59,60	64,00	67,40	72,00	75,70			35	1200	0,31	2,4	3,70	4,80	5,20
1300	32,35	39,89	43,43	46,86	50,97	54,87	57,80	61,20	66,00	69,00	73,10			1300							
1400	33,30	41,71	45,36	48,86	53,02	54,00	58,00	62,00	66,30	70,00					40	1400					
1440	34,25	42,39	46,06	49,58	53,80	56,30	62,80	66,00	70,00							1440	0,5	2,7	4,60	6,00	6,30
1500	34,90	43,34	46,20	50,59	54,00	56,50	62,50	66,60	69,10							1500					
1600	35,20	43,30	46,00	50,50	54,00	56,50	62,50								40	1600	0,6	3	5,00	6,60	7,00
1700	36,40	43,20	46,00	49,40	53,50	56,80								1700							
1800	37,00	43,00	45,70	49,10											40	1800	0,7	3,2	5,60	6,80	7,40
1900	37,3	42,1	45,40											1900							
2000	37,00	41,90												2000							

Basic power for theoretical 25.000 hrs belt life

## SECTION XPZ/3VX

RPM small pulley	BASIC POWER IN KW SMALL PULLEY DIAMETER															VBelt speed m/s	Additional power (Kw) for speed ratio					
																	RPM	1,01 to 1,05	1,06 to 1,26	1,27 to 1,57	1,58 to 3,38	over 3,39
	63	67	71	75	80	85	90	95	100	106	112	118	125	132	140							
100	0,13	0,16	0,17	0,20	0,21	0,24	0,26	0,29	0,32	0,34	0,37	0,40	0,42	0,46	0,38	100	0,00	0,01	0,01	0,02	0,02	
200	0,24	0,28	0,32	0,36	0,40	0,45	0,49	0,53	0,58	0,63	0,69	0,74	0,79	0,86	0,70	200	0,00	0,02	0,02	0,03	0,03	
300	0,34	0,40	0,45	0,50	0,57	0,63	0,70	0,77	0,83	0,90	0,98	1,06	1,15	1,24	1,01	300	0,00	0,03	0,04	0,05	0,05	
400	0,44	0,50	0,57	0,63	0,73	0,81	0,90	0,98	1,07	1,16	1,27	1,36	1,48	1,60	1,31	400	0,01	0,03	0,05	0,06	0,06	
500	0,51	0,59	0,69	0,77	0,87	0,98	1,08	1,19	1,29	1,41	1,54	1,66	1,81	1,94	1,60	500	0,01	0,04	0,06	0,08	0,08	
600	0,59	0,70	0,79	0,90	1,02	1,15	1,27	1,39	1,52	1,66	1,81	1,95	2,13	2,28	1,88	600	0,01	0,05	0,07	0,09	0,10	
700	0,67	0,79	0,90	1,02	1,16	1,31	1,45	1,58	1,73	1,90	2,07	2,23	2,43	2,61	2,15	700	0,01	0,06	0,09	0,11	0,11	
720	0,69	0,81	0,92	1,04	1,19	1,33	1,48	1,62	1,77	1,94	2,11	2,28	2,48	2,68	2,20	720	0,01	0,06	0,09	0,11	0,12	
800	0,74	0,87	1,00	1,14	1,31	1,47	1,62	1,78	1,94	2,14	2,32	2,51	2,73	2,94	2,42	800	0,01	0,07	0,10	0,12	0,13	
900	0,82	0,96	1,11	1,25	1,44	1,61	1,80	1,97	2,15	2,36	2,57	2,79	3,02	3,26	2,68	900	0,01	0,08	0,11	0,14	0,14	
960	0,86	1,02	1,16	1,32	1,52	1,70	1,90	2,09	2,27	2,49	2,72	2,94	3,19	3,46	2,84	960	0,01	0,08	0,12	0,15	0,15	
1000	0,88	1,04	1,20	1,37	1,57	1,77	1,97	2,15	2,35	2,59	2,81	3,05	3,31	3,58	2,94	1000	0,01	0,09	0,12	0,15	0,16	
1100	0,95	1,12	1,31	1,48	1,69	1,91	2,13	2,34	2,55	2,80	3,06	3,30	3,59	3,88	3,19	1100	0,01	0,10	0,14	0,17	0,18	
1200	1,02	1,20	1,40	1,58	1,82	2,06	2,28	2,52	2,75	3,02	3,29	3,56	3,88	4,18	3,44	1200	0,02	0,10	0,15	0,18	0,19	
1300	1,08	1,28	1,49	1,69	1,94	2,19	2,44	2,69	2,94	3,23	3,52	3,81	4,14	4,49	3,68	1300	0,02	0,11	0,16	0,20	0,21	
1400	1,14	1,36	1,57	1,80	2,06	2,34	2,60	2,86	3,13	3,45	3,75	4,07	4,42	4,78	3,92	1400	0,02	0,12	0,17	0,21	0,23	
1440	1,16	1,39	1,61	1,83	2,11	2,39	2,65	2,93	3,19	3,52	3,84	4,16	4,53	4,90	4,02	1440	0,02	0,13	0,18	0,22	0,23	
1500	1,20	1,43	1,66	1,89	2,18	2,47	2,75	3,04	3,31	3,64	3,97	4,30	4,69	5,06	4,16	1500	0,02	0,13	0,19	0,23	0,24	
1600	1,25	1,50	1,74	1,99	2,30	2,60	2,90	3,19	3,50	3,84	4,20	4,54	4,95	5,35	4,39	1600	0,02	0,14	0,20	0,24	0,26	
1700	1,31	1,57	1,83	2,09	2,42	2,73	3,05	3,37	3,67	4,04	4,41	4,78	5,20	5,62	4,62	1700	0,02	0,15	0,21	0,26	0,27	
1800	1,36	1,64	1,91	2,19	2,52	2,86	3,19	3,52	3,85	4,24	4,62	5,02	5,45	5,89	4,84	1800	0,02	0,16	0,22	0,27	0,29	
1900	1,41	1,70	1,99	2,28	2,63	2,98	3,33	3,68	4,03	4,44	4,83	5,24	5,70	6,16	5,06	1900	0,03	0,17	0,24	0,29	0,31	
2000	1,47	1,77	2,07	2,38	2,75	3,10	3,47	3,83	4,20	4,62	5,04	5,46	5,94	6,42	5,27	2000	0,03	0,17	0,25	0,30	0,32	
2100	1,52	1,83	2,15	2,46	2,85	3,23	3,60	3,99	4,36	4,80	5,24	5,68	6,18	6,68	5,48	2100	0,03	0,18	0,26	0,32	0,34	
2200	1,57	1,90	2,22	2,55	2,96	3,35	3,75	4,13	4,53	4,99	5,44	5,90	6,42	6,93	5,69	2200	0,03	0,19	0,27	0,33	0,35	
2300	1,61	1,95	2,30	2,64	3,05	3,47	3,88	4,29	4,69	5,16	5,64	6,11	6,64	7,18	5,89	2300	0,03	0,20	0,29	0,35	0,37	
2400	1,66	2,02	2,38	2,72	3,15	3,58	4,01	4,44	4,84	5,35	5,83	6,31	6,86	7,42	6,09	2400	0,03	0,21	0,30	0,36	0,39	
2500	1,70	2,07	2,44	2,80	3,25	3,70	4,13	4,57	5,00	5,52	6,02	6,52	7,09	7,66	6,28	2500	0,03	0,22	0,31	0,38	0,40	
2600	1,76	2,14	2,51	2,89	3,35	3,80	4,26	4,71	5,16	5,69	6,20	6,72	7,31	7,88	6,47	2600	0,04	0,23	0,32	0,40	0,42	
2700	1,80	2,19	2,57	2,97	3,45	3,92	4,38	4,84	5,31	5,85	6,39	6,92	7,51	8,12	6,65	2700	0,04	0,24	0,33	0,41	0,43	
2800	1,83	2,24	2,64	3,05	3,54	4,03	4,50	4,99	5,45	6,01	6,56	7,10	7,72	8,33	6,83	2800	0,04	0,24	0,35	0,43	0,45	
2880	1,87	2,28	2,69	3,10	3,60	4,11	4,61	5,10	5,57	6,14	6,71	7,25	7,88	8,50	6,97	2880	0,04	0,25	0,36	0,44	0,45	
2900	1,87	2,30	2,71	3,12	3,63	4,13	4,62	5,12	5,60	6,18	6,73	7,29	7,92	8,55	7,00	2900	0,04	0,25	0,36	0,44	0,47	
3000	1,91	2,35	2,77	3,19	3,72	4,24	4,74	5,24	5,74	6,32	6,90	7,47	8,12	8,75	7,17	3000	0,04	0,26	0,37	0,46	0,48	
3100	1,95	2,40	2,84	3,27	3,80	4,33	4,86	5,37	5,87	6,48	7,08	7,66	8,32	8,96	7,33	3100	0,04	0,27	0,38	0,47	0,50	
3200	1,99	2,44	2,89	3,34	3,89	4,44	4,96	5,49	6,02	6,63	7,23	7,83	8,50	9,16	7,49	3200	0,04	0,28	0,40	0,49	0,51	
3300	2,03	2,49	2,96	3,41	3,97	4,53	5,08	5,62	6,15	6,77	7,39	8,00	8,69	9,35	7,65	3300	0,04	0,29	0,41	0,50	0,53	
3400	2,06	2,53	3,01	3,48	4,05	4,62	5,19	5,74	6,28	6,92	7,55	8,16	8,86	9,54	7,80	3400	0,05	0,30	0,42	0,52	0,55	
3500	2,10	2,59	3,06	3,55	4,13	4,71	5,29	5,85	6,40	7,06	7,70	8,32	9,03	9,72	7,94	500	0,05	0,31	0,43	0,53	0,56	

Basic power for theoretical 25.000 hrs belt life

## SEZIONE XPA

RPM small pulley	BASIC POWER IN KW SMALL PULLEY DIAMETER														VBelt speed m/s	Additional power (Kw) for speed ratio																												
	90	95	100	106	112	118	125	132	140	150	160	180	200	RPM		1,01 to 1,05	1,06 to 1,26	1,27 to 1,57	1,58 to 3,38	over 3,39																								
	100	0,30	0,36	0,40	0,44	0,49	0,54	0,59	0,65	0,71	0,79	0,87	1,03	1,19		10	100	0,00	0,02	0,03	0,04	0,04	200	0,01	0,04	0,06	0,08	0,08	300	0,01	0,07	0,10	0,12	0,12	400	0,01	0,09	0,13	0,16	0,16	500	0,02	0,11	0,16
200	0,55	0,62	0,70	0,79	0,90	0,99	1,10	1,20	1,32	1,48	1,62	1,93	2,22	600	0,02		0,13	0,19	0,23	0,25	700	0,02	0,16	0,22	0,27	0,29	720	0,02	0,16	0,23	0,28	0,30	800	0,03	0,18	0,25	0,31	0,33	900	0,03	0,20	0,29	0,35	0,37
300	0,77	0,87	0,99	1,12	1,25	1,40	1,56	1,70	1,89	2,11	2,32	2,76	3,19	960	0,03		0,21	0,30	0,37	0,40	1000	0,03	0,22	0,32	0,39	0,41	1100	0,04	0,25	0,35	0,43	0,45	1200	0,04	0,27	0,38	0,47	0,49	1300	0,04	0,29	0,41	0,51	0,54
400	0,95	1,11	1,25	1,43	1,61	1,78	1,99	2,19	2,43	2,71	3,00	3,56	4,13	1400	0,05		0,31	0,44	0,54	0,58	1440	0,05	0,32	0,46	0,56	0,59	1500	0,05	0,34	0,48	0,58	0,62	1600	0,06	0,36	0,51	0,62	0,66	1700	0,06	0,38	0,54	0,66	0,70
500	1,14	1,32	1,50	1,73	1,94	2,15	2,40	2,65	2,94	3,29	3,64	4,34	5,03	1800	0,06		0,40	0,57	0,70	0,74	1900	0,07	0,43	0,60	0,74	0,78	2000	0,07	0,45	0,64	0,78	0,82	2100	0,07	0,47	0,67	0,82	0,87	2200	0,08	0,49	0,70	0,86	0,91
600	1,31	1,53	1,74	2,01	2,26	2,51	2,81	3,10	3,45	3,85	4,28	5,10	5,90	2300	0,08		0,51	0,73	0,90	0,95	2400	0,08	0,54	0,76	0,93	0,99	2500	0,09	0,56	0,79	0,97	1,03	2600	0,09	0,58	0,83	1,01	1,07	2700	0,09	0,60	0,86	1,05	1,11
700	1,48	1,73	1,97	2,27	2,56	2,86	3,19	3,54	3,92	4,41	4,88	5,82	6,76	2800	0,10		0,63	0,89	1,09	1,15	2880	0,10	0,64	0,91	1,12	1,19	2900	0,10	0,65	0,92	1,13	1,20	3000	0,10	0,67	0,95	1,17	1,24	3100	0,11	0,69	0,98	1,21	1,28
720	1,50	1,77	2,02	2,32	2,63	2,93	3,27	3,63	4,03	4,51	5,00	5,97	6,92	3200	0,11		0,72	1,02	1,25	1,32	3300	0,11	0,74	1,05	1,28	1,36	3400	0,12	0,76	1,08	1,32	1,40	3500	0,12	0,78	1,11	1,36	1,44						
800	1,64	1,91	2,19	2,53	2,86	3,19	3,58	3,96	4,40	4,94	5,48	6,53	7,58	3300	0,11		0,74	1,05	1,28	1,36	3400	0,12	0,76	1,08	1,32	1,40	3500	0,12	0,78	1,11	1,36	1,44												
900	1,78	2,10	2,40	2,79	3,15	3,52	3,95	4,37	4,86	5,45	6,05	7,23	8,40	3200	0,11		0,72	1,02	1,25	1,32	3300	0,11	0,74	1,05	1,28	1,36	3400	0,12	0,76	1,08	1,32	1,40	3500	0,12	0,78	1,11	1,36	1,44						
960	1,86	2,20	2,53	2,90	3,31	3,71	4,16	4,62	5,12	5,76	6,39	7,64	8,87	3200	0,11	0,72	1,02	1,25	1,32	3300	0,11	0,74	1,05	1,28	1,36	3400	0,12	0,76	1,08	1,32	1,40	3500	0,12	0,78	1,11	1,36	1,44							
1000	1,93	2,27	2,61	3,02	3,43	3,84	4,30	4,78	5,31	5,97	6,61	7,91	9,17	3200	0,11	0,72	1,02	1,25	1,32	3300	0,11	0,74	1,05	1,28	1,36	3400	0,12	0,76	1,08	1,32	1,40	3500	0,12	0,78	1,11	1,36	1,44							
1100	2,06	2,44	2,81	3,26	3,70	4,14	4,66	5,16	5,74	6,45	7,17	8,57	9,94	3200	0,11	0,72	1,02	1,25	1,32	3300	0,11	0,74	1,05	1,28	1,36	3400	0,12	0,76	1,08	1,32	1,40	3500	0,12	0,78	1,11	1,36	1,44							
1200	2,19	2,60	3,00	3,48	3,96	4,45	4,99	5,54	6,16	6,94	7,71	9,21	10,69	3200	0,11	0,72	1,02	1,25	1,32	3300	0,11	0,74	1,05	1,28	1,36	3400	0,12	0,76	1,08	1,32	1,40	3500	0,12	0,78	1,11	1,36	1,44							
1300	2,32	2,76	3,19	3,71	4,22	4,74	5,33	5,91	6,59	7,41	8,22	9,85	11,42	3200	0,11	0,72	1,02	1,25	1,32	3300	0,11	0,74	1,05	1,28	1,36	3400	0,12	0,76	1,08	1,32	1,40	3500	0,12	0,78	1,11	1,36	1,44							
1400	2,44	2,90	3,37	3,92	4,47	5,02	5,65	6,28	7,00	7,87	8,74	10,45	12,13	3200	0,11	0,72	1,02	1,25	1,32	3300	0,11	0,74	1,05	1,28	1,36	3400	0,12	0,76	1,08	1,32	1,40	3500	0,12	0,78	1,11	1,36	1,44							
1440	2,48	2,97	3,45	4,01	4,57	5,13	5,78	6,43	7,15	8,05	8,95	10,69	12,41	3200	0,11	0,72	1,02	1,25	1,32	3300	0,11	0,74	1,05	1,28	1,36	3400	0,12	0,76	1,08	1,32	1,40	3500	0,12	0,78	1,11	1,36	1,44							
1500	2,56	3,05	3,55	4,13	4,71	5,29	5,97	6,64	7,39	8,32	9,24	11,05	12,82	3200	0,11	0,72	1,02	1,25	1,32	3300	0,11	0,74	1,05	1,28	1,36	3400	0,12	0,76	1,08	1,32	1,40	3500	0,12	0,78	1,11	1,36	1,44							
1600	2,67	3,19	3,71	4,34	4,95	5,57	6,27	6,98	7,77	8,76	9,73	11,63	13,48	3200	0,11	0,72	1,02	1,25	1,32	3300	0,11	0,74	1,05	1,28	1,36	3400	0,12	0,76	1,08	1,32	1,40	3500	0,12	0,78	1,11	1,36	1,44							
1700	2,77	3,33	3,88	4,54	5,19	5,83	6,57	7,31	8,16	9,19	10,20	12,20	14,12	3200	0,11	0,72	1,02	1,25	1,32	3300	0,11	0,74	1,05	1,28	1,36	3400	0,12	0,76	1,08	1,32	1,40	3500	0,12	0,78	1,11	1,36	1,44							
1800	2,88	3,46	4,04	4,73	5,41	6,09	6,86	7,64	8,51	9,60	10,67	12,74	14,76	3200	0,11	0,72	1,02	1,25	1,32	3300	0,11	0,74	1,05	1,28	1,36	3400	0,12	0,76	1,08	1,32	1,40	3500	0,12	0,78	1,11	1,36	1,44							
1900	2,97	3,59	4,20	4,91	5,62	6,34	7,15	7,96	8,88	10,01	11,11	13,27	15,35	3200	0,11	0,72	1,02	1,25	1,32	3300	0,11	0,74	1,05	1,28	1,36	3400	0,12	0,76	1,08	1,32	1,40	3500	0,12	0,78	1,11	1,36	1,44							
2000	3,08	3,71	4,34	5,10	5,83	6,57	7,43	8,28	9,23	10,40	11,55	13,78	15,93	3200	0,11	0,72	1,02	1,25	1,32	3300	0,11	0,74	1,05	1,28	1,36	3400	0,12	0,76	1,08	1,32	1,40	3500	0,12	0,78	1,11	1,36	1,44							
2100	3,17	3,83	4,49	5,27	6,05	6,81	7,70	8,58	9,57	10,78	11,97	14,28	16,49	3200	0,11	0,72	1,02	1,25	1,32	3300	0,11	0,74	1,05	1,28	1,36	3400	0,12	0,76	1,08	1,32	1,40	3500	0,12	0,78	1,11	1,36	1,44							
2200	3,25	3,95	4,62	5,44	6,24	7,05	7,96	8,87	9,89	11,15	12,38	14,76	17,03	3200	0,11	0,72	1,02	1,25	1,32	3300	0,11	0,74	1,05	1,28	1,36	3400	0,12	0,76	1,08	1,32	1,40	3500	0,12	0,78	1,11	1,36	1,44							
2300	3,33	4,05	4,77	5,61	6,44	7,26	8,22	9,16	10,22	11,51	12,78	15,22	17,53	3200	0,11	0,72	1,02	1,25	1,32	3300	0,11	0,74	1,05	1,28	1,36	3400	0,12	0,76	1,08	1,32	1,40	3500	0,12	0,78	1,11	1,36	1,44							
2400	3,41	4,16	4,88	5,77	6,63	7,48	8,46	9,42	10,52	11,85	13,15	15,66	18,02	3200	0,11	0,72	1,02	1,25	1,32	3300	0,11	0,74	1,05	1,28	1,36	3400	0,12	0,76	1,08	1,32	1,40	3500	0,12	0,78	1,11	1,36	1,44							
2500	3,48	4,25	5,02	5,91	6,81	7,70	8,70	9,70	10,81	12,18	13,52	16,06	18,47	3200	0,11	0,72	1,02	1,25	1,32	3300	0,11	0,74	1,05	1,28	1,36	3400	0,12	0,76	1,08	1,32	1,40	3500	0,12	0,78	1,11	1,36	1,44							
2600	3,55	4,34	5,13	6,06	6,98	7,89	8,94	9,95	11,10	12,50	13,86	16,47	18,90	3200	0,11	0,72	1,02	1,25	1,32	3300	0,11	0,74	1,05	1,28	1,36	3400	0,12	0,76	1,08	1,32	1,40	3500	0,12	0,78	1,11	1,36	1,44							
2700	3,62	4,44	5,25	6,20	7,15	8,08	9,15	10,20	11,38	12,82	14,20	16,84	19,31	3200	0,11	0,72	1,02	1,25	1,32	3300	0,11	0,74	1,05	1,28	1,36	3400	0,12	0,76	1,08	1,32	1,40	3500	0,12	0,78	1,11	1,36	1,44							
2800	3,68	4,53	5,36	6,35	7,31	8,26	9,36	10,44	11,64	13,11	14,52	17,20	19,68	3200	0,11	0,72	1,02	1,25	1,32	3300	0,11	0,74	1,05	1,28	1,36	3400	0,12	0,76	1,08	1,32	1,40	3500	0,12	0,78	1,11	1,36	1,44							
2880	3,74	4,59	5,44	6,44	7,44	8,41	9,53	10,63	11,84	13,33	14,77	17,48	-	3200	0,11	0,72	1,02	1,25	1,32	3300	0,11	0,74	1,05	1,28	1,36	3400	0,12	0,76	1,08	1,32	1,40	3500	0,12	0,78	1,11	1,36	1,44							
2900	3,75	4,61	5,46	6,47	7,47	8,45	9,57	10,67	11,89	13,38	14,82	17,54	-	3200	0,11	0,72	1,02	1,25	1,32	3300	0,11																							

## SEZIONE XPB/5VX

RPM small pulley	BASIC POWER IN KW SMALL PULLEY DIAMETER											VBelt speed m/s	Additional power (Kw) for speed ratio					
	160	170	180	190	200	212	224	236	250	280	315		RPM	1,01 to 1,05	1,06 to 1,26	1,27 to 1,57	1,58 to 3,38	over 3,39
100	1,11	1,23	1,35	1,48	1,60	1,74	1,89	1,91	2,19	2,56	2,97	10	100	0,01	0,04	0,07	0,08	0,08
200	2,02	2,26	2,49	2,72	2,96	3,23	3,51	3,78	4,09	4,78	5,56		200	0,01	0,09	0,13	0,16	0,17
300	2,86	3,21	3,55	3,88	4,22	4,62	5,03	5,43	5,89	6,86	8,00		300	0,02	0,14	0,20	0,24	0,25
400	3,66	4,11	4,55	4,99	5,43	5,95	6,47	6,98	7,35	8,87	10,34		400	0,03	0,19	0,26	0,32	0,34
500	4,42	4,96	5,50	6,05	6,59	7,22	7,87	8,50	9,23	10,80	12,58		500	0,04	0,23	0,33	0,40	0,43
600	5,15	5,79	6,43	7,08	7,70	8,46	9,20	9,95	10,81	12,65	14,74	20	600	0,04	0,28	0,40	0,48	0,51
700	5,85	6,59	7,33	8,05	8,78	9,65	10,51	11,37	12,36	14,44	16,83		700	0,05	0,33	0,46	0,57	0,59
720	5,99	6,75	7,50	8,25	8,99	9,89	10,76	11,64	12,65	14,80	17,24		720	0,05	0,33	0,53	0,59	0,62
800	6,53	7,37	8,18	9,02	9,83	10,80	11,76	12,72	13,83	16,18	18,85		800	0,06	0,37	0,53	0,65	0,69
900	7,18	8,10	9,03	9,94	10,84	11,92	12,99	14,04	15,27	17,86	20,78		900	0,07	0,42	0,60	0,72	0,77
960	7,56	8,54	9,52	10,48	11,43	12,57	13,70	14,82	16,10	18,82	21,91	30	960	0,07	0,44	0,62	0,77	0,81
1000	7,81	8,83	9,83	10,84	11,83	13,00	14,16	15,33	16,66	19,47	22,64		1000	0,07	0,46	0,66	0,81	0,86
1100	8,43	9,53	10,63	11,71	12,78	14,04	15,31	16,55	17,99	21,01	24,42		1100	0,08	0,51	0,72	0,89	0,94
1200	9,02	10,20	11,38	12,54	13,70	15,06	16,42	17,75	19,29	22,51	26,00		1200	0,09	0,56	0,79	0,97	1,03
1300	9,60	10,86	12,12	13,36	14,59	16,04	17,48	18,90	20,53	23,93	27,71		1300	0,09	0,60	0,86	1,05	1,11
1400	10,15	11,50	12,83	14,14	15,44	16,99	18,51	20,00	21,71	25,28	29,22	30	1400	0,10	0,65	0,93	1,13	1,20
1440	10,36	11,73	13,11	14,45	15,77	17,36	18,90	20,43	22,18	25,81	29,79		1440	0,10	0,66	0,94	1,15	1,21
1500	10,68	12,10	13,52	14,90	16,28	17,90	19,48	21,05	22,85	26,56	30,64		1500	0,10	0,69	0,99	1,21	1,28
1600	11,19	12,70	14,18	15,63	17,07	18,77	20,43	22,07	23,93	27,77	31,96		1600	0,11	0,75	1,05	1,29	1,37
1700	11,68	13,25	14,81	16,33	17,83	19,60	21,33	23,02	24,95	28,91	33,16		1700	0,12	0,79	1,12	1,37	1,45
1800	12,16	13,79	15,42	17,00	18,56	20,39	22,19	23,93	25,92	29,96	34,27	30	1800	0,13	0,84	1,19	1,45	1,54
1900	12,62	14,32	16,00	17,64	19,25	21,15	22,99	24,79	26,82	30,94			1900	0,13	0,88	1,25	1,54	1,63
2000	13,04	14,81	16,55	18,24	19,91	21,86	23,75	25,59	27,67	31,83			2000	0,14	0,93	1,32	1,62	1,71
2100	13,45	15,29	17,07	18,82	20,53	22,53	24,46	26,33	28,43				2100	0,15	0,98	1,39	1,69	1,79
2200	13,85	15,73	17,57	19,36	21,12	23,15	25,13	27,02	29,15				2200	0,16	1,02	1,45	1,78	1,88
2300	14,22	16,14	18,03	19,88	21,66	23,73	25,74	27,65				30	2300	0,16	1,07	1,51	1,86	1,97
2400	14,56	16,54	18,48	20,35	22,16	24,27	26,29	28,22					2400	0,17	1,11	1,58	1,94	2,05
2500	14,88	16,91	18,88	20,79	22,64	24,76	26,80						2500	0,18	1,16	1,65	2,02	2,14
2600	15,18	17,25	19,26	21,20	23,06	25,20							2600	0,19	1,21	1,72	2,10	2,22
2700	15,46	17,57	19,60	21,56	23,44	25,59							2700	0,19	1,25	1,78	2,18	2,31
2800	15,71	17,85	19,91	21,89	23,77							30	2800	0,20	1,29	1,84	2,26	2,39
2880	15,89	18,06	20,13	22,12									2880	0,20	1,32	1,88	2,31	2,44
2900	15,93	18,10	20,18	22,18									2900	0,21	1,34	1,91	2,34	2,48
3000	16,13	18,33	20,42	22,43									3000	0,22	1,39	1,98	2,42	2,57

Basic power for theoretical 25.000 hrs belt life

## SEZIONE XPC

RPM small pulley	BASIC POWER IN KW SMALL PULLEY DIAMETER																VBelt speed m/s	RPM	Additional power (Kw) for speed ratio					
	224	236	250	265	280	300	315	335	355	375	400	425	450	475	500	530			560	1,01 to 1,05	1,06 to 1,26	1,27 to 1,57	1,58 to 3,38	over 3,39
	100	2,43	2,68	2,99	3,32	3,65	4,07	4,39	4,83	5,26	5,67	5,90	6,40	6,90	7,40	7,89			8,48	9,07	100	0,02	0,14	0,20
200	4,38	4,88	5,47	6,09	6,70	7,53	8,14	8,94	9,76	10,57	11,00	11,95	12,89	13,83	14,76	15,87	16,98	200	0,04	0,29	0,41	0,50	0,53	
300	6,15	6,88	7,72	8,63	9,53	10,71	11,60	12,79	13,96	15,12	15,75	171,40	18,48	19,84	21,18	22,78	24,37	300	0,07	0,43	0,61	0,75	0,79	
400	7,81	8,75	9,85	11,03	12,19	13,74	14,88	16,41	17,93	19,43	20,27	22,03	23,78	25,52	27,24	29,29	31,32	400	0,09	0,57	0,81	1,00	1,06	
500	9,36	10,52	11,86	13,30	14,71	16,60	18,01	19,86	21,72	23,55	24,55	26,68	28,79	30,89	32,97	35,43	37,86	500	0,11	0,72	1,02	1,25	1,32	
600	10,82	12,19	13,76	15,45	17,13	19,34	20,98	23,16	25,32	27,45	28,62	31,09	33,55	35,96	38,35	41,18	78,75	600	0,13	0,86	1,22	1,50	1,59	
700	12,20	13,77	15,58	17,51	19,42	21,94	23,81	26,29	28,74	31,16	32,47	35,26	38,01	40,73	43,38	46,53	49,59	700	0,15	1	1,43	1,75	1,85	
720	12,47	14,08	15,93	17,91	19,86	22,45	24,36	26,90	29,40	31,88	33,21	36,06	38,87	41,63	44,35	47,55	50,66	720	0,16	1,03	1,46	1,80	1,90	
800	13,52	15,27	17,31	19,46	21,61	24,42	26,51	29,27	31,99	34,67	36,10	39,17	42,19	45,16	48,05	51,43	54,73	800	0,17	1,15	1,63	2,00	2,11	
900	14,76	16,70	18,95	21,33	23,68	26,78	29,06	32,09	35,05	37,97	39,50	42,83	46,06	49,23	52,30	55,89	59,33	900	0,2	1,29	1,85	2,25	2,38	
960	15,47	17,52	19,86	22,39	24,86	28,12	30,52	33,68	36,80	39,85	41,42	44,88	48,23	51,49	54,66	58,31	61,82	960	0,21	1,37	1,95	2,40	2,54	
1000	15,93	18,04	20,50	23,08	25,64	29,00	31,48	34,73	37,92	41,04	42,65	46,19	49,61	52,93	56,13	59,83	63,35	1000	0,22	1,43	2,04	2,50	2,64	
1100	17,03	19,31	21,96	24,74	27,49	31,09	33,73	37,20	40,59	43,90	45,55	49,25	52,80	56,23	59,50	61,48	65,92	1100	0,24	1,57	2,24	2,75	2,91	
1200	18,07	20,51	23,33	26,29	29,22	33,04	35,84	39,49	43,05	46,51	48,19	51,99	55,63	59,09	60,91	63,80	66,79	1200	0,26	1,72	2,44	3,00	3,17	
1300	19,39	21,62	24,61	27,74	30,83	34,84	37,78	41,59	45,29	48,86	50,53	54,40	57,88	61,32	63,80	65,95	68,14	1300	0,28	1,86	2,65	3,25	3,44	
1400	19,90	22,64	25,79	29,08	32,31	36,50	39,55	43,49	47,30	50,95	52,57	54,91	59,19	61,58	64,55	66,63	68,96	1400	0,31	2	2,85	3,50	3,70	
1440	20,24	23,03	26,23	29,59	32,87	37,12	40,21	44,20	48,03	51,70	53,10	55,46	59,79	62,20	65,20	67,30	69,65	1440	0,31	2,06	2,93	3,50	3,81	
1500	20,72	23,58	26,86	30,30	33,66	38,00	41,15	45,19	49,07	52,75	53,41	55,79	60,14	62,57	65,59	66,12	70,07	1500	0,33	2,15	3,05	3,75	3,96	
1600	21,45	24,44	27,85	31,42	34,88	39,33	42,55	46,67	50,57	53,78	54,17	56,65	60,55	62,76	64,96			1600	0,35	2,29	3,26	4,00	4,23	
1700	22,09	25,19	28,73	32,40	35,95	40,50	43,77	47,91	51,33	54,16	54,90	57,37	61,33					1700	0,37	2,43	3,46	4,25	4,49	
1800	22,66	25,86	29,50	33,26	36,88	41,49	44,79	48,87	52,19	54,77	56,23	58,75	62,00					1800	0,39	2,58	3,66	4,50	4,76	
1900	23,14	26,44	30,15	33,98	37,66	42,30	45,19	49,38	52,46	54,97	56,72							1900	0,42	2,72	3,87	4,75	5,02	
2000	23,53	26,90	30,68	34,57	38,27	43,37	46,30	49,79	52,86	56,10	55,27							2000	0,44	2,86	4,07	5,00	5,29	

Basic power for theoretical 25.000 hrs belt life

## BELTS TENSIONING

Type	Small pulley diameter mm	Static tensioning per span [N]			
		wrapped belts		raw edge belts	
		first tensioning	operating tension	first tensioning	operating tension
SPZ - XPZ 3V - 3VX	< 71	200	150	250	200
	71 > 90	250	200	300	250
	90 > 125	300	250	350	300
	over	to be calculated			
SPA XPA	< 100	350	250	400	300
	100 > 140	400	300	500	400
	140 > 200	500	400	600	450
	over	to be calculated			
SPB - XPB 5V - 5VX	< 160	650	500	700	550
	160 > 224	700	550	850	650
	224 > 355	900	700	1000	800
	over	to be calculated			
SPC XPC	< 250	1000	800	1400	1100
	250 > 355	1400	1100	1600	1200
	355 > 560	1800	1400	1900	1500
	over	to be calculated			
Z ZX	< 50	90	70	120	90
	50 > 71	120	90	140	110
	71 > 100	140	110	160	130
	over	to be calculated			
A AX	< 80	150	110	200	150
	80 > 100	200	150	250	200
	100 > 132	300	250	400	300
	over	to be calculated			
B BX	< 125	300	250	450	350
	125 > 160	400	350	500	400
	160 > 200	500	400	600	450
	over	to be calculated			
C CX	< 200	700	500	800	600
	200 > 250	800	600	900	700
	250 > 355	900	700	1000	800
	over	to be calculated			

Type	Small pulley diameter mm	Static tensioning per rib [N]			
		PolyV PJ		PolyV PL	
		first tensioning	operating tension	first tensioning	operating tension
PolyV	< 40	50	38		
	40 > 80	50	38	130	100
	80 > 132	62	50	165	130
	132 > 200	to be calculated		140	180
	over	to be calculated		to be calculated	

The values shown are approximate, provided in the absence of a complete calculation of the transmission and refer to the maximum power rating of the belt

## INSTALLATION ADVICE

It is generally advisable to use drives with adjustable wheelbase.

The fixed distances automatically require an idler pulley tensioner: In the case of adjustable axes (engine or machine on a sliding base is advisable that the real distance between the axes can be shortened or elongated, so as to allow the mounting and tensioning of the belts .

$$x + y = 0,045 L \quad \text{con} \quad L = \text{lunghezza cinghie}; \quad x = 0,030L; \quad y = 0,015 L$$

If the distance is fixed, the tensioner must have sufficient, slack taking into account the above advice.

### PULLEY PARALLEL DEVIATION

Any out of parallel deviation = max 0,5% of the centre distance

### BELT TENSIONING

#### Method of deflection.

A method to be used in preference to the transmissions of low power or with a short centre distance. Fit the belts on pulleys aligned correctly. Slide the engine or apply the tensioner until the two branches are no longer loose. Tensioning the belts gradually by turning the transmission of a few turns after each shot and measuring belt deflection  $f$  at the center of span ; the deflection obtained at the span center under the deflection force  $F$  calculated and exerted perpendicularly to the belt.

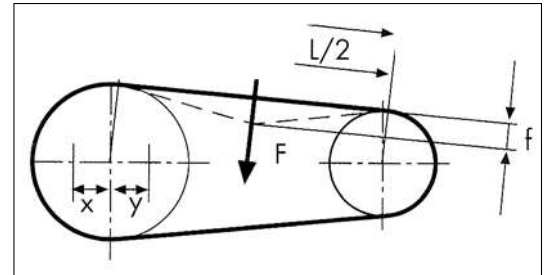

#### Method of stretching.

To be used in preference to the transmission of high power and large centre distances, or transmission with multiband belts .Mount the belts on pulleys aligned correctly. Slide the engine or apply the tensioner until the two branches are no more loose. Put on the back of the belt two transverse lines as far as possible from one another, but always on the same span of the belt. Gradually tighten the belts by turning the transmission of some turns after each shot until the length of tension between the two lines increases the percentage as specified in the table below.

Example: initial centre distance of 1000 mm between the two lines turn in 1006 mm (+ 0,6%), 1008 mm (+ 0,8%) o 1010 mm (+ 1%)

		torque or resistance uniforms	torque or resistance variables	torque or resistance highly variable
medium extension in %	Narrow Vbelt	0,6	0,8	1
	Classical Vbelt	0,5	0,6	0,8

The values of elongation in% shown in this table, and those obtained as a result of the formulas to calculate deflection force, are effective values of service. Therefore, taking into account variations due to the break-in, it is advisable to retension belts after a few hours of service in order to return to the initial value of elongation  $A\%$ , or deflection force - to ensure reliable operation of the transmission.

## DURING OF LIFE

### THEORY

When a belt transmits power , the tension cable are subject to a number of efforts :

- the tractive effort on the torque to be transmitted ;
- a tensile stress due to centrifugal force , which tends to bring out the belt from the throat ;
- a tensile stress complementary , due to the tension of the assembly, which is necessary to avoid an abnormal slipping during the service ;
- a tensile stress caused by the bending of the belt in the instant when they enter into the pulley grooves .

It is the cyclic repetition of these tensile stresses that generates a fatigue of service , to consider when we calculate the gross transmitted powers. This statement is based on the following:

We can assume that a belt with a certain length travels a certain distance and at certain speed. We add a notion of wear rate , that is a theoretical speed at which a belt with a given length is consumed . From this speed and known distance, we can deduce the work time, or in other words , the theoretical time of during of life .The transmissible powers indicated in mentioned tables are referred to a life of 25 000 hours.

### CHOOSING A TRANSMISSION

- Considering these theoretical notions, be sure to apply the proper service factor to the power to be transmitted. In fact, it is precisely this element of service which gives you the ability to move from theory to practice, because it is dependent on the specific characteristics of the transmission (eg, number of starts, irregularities in the operation, external influences, ...)
- It is very important to remember that the bending stress due to the winding on the smaller pulley, is particularly damaging to the longevity of the belt. Therefore, you should always use the pulley diameters as big as possible, and never less than the minimum diameters indicated.

### TENSION

In addition to checking that the shafts are parallel and that the transmission is properly aligned, it is also very important for life of belts, apply the correct tension. Insufficient tension results in slippage with overheating and consequent damage to the belts or limits the ability to absorb torque peaks to which the transmission is subject.

**WARNING!** Tension mounting or stretching does not remain constant during the initial service. The belts fit and have a variable elongation during their useful life

**TENSIONING VALUE-** or elongation indicated on the following pages , are always tension or elongation in standard conditions of speed.

### BREAK-IN PERIOD

Since the sides of the belt fit the pulley grooves and since the components are stabilized during the service, the mounting tension will decrease.

During the first few minutes of operation , there is an elongation of the belt higher than the actual elongation of the cables .

From the moment when the belt begins to move , the elongation mounting decreases again , because the belts will fit, and then they find a stable value which corresponds to 60-70% of the original value. Tension the belt after a break-in period of a few hours , applying a tension force additional 50 to 60 % of the value initially applied. There will be a new loss of tension, before stabilizing the value of effective elongation (  $A_{eff}$  ) required. Graph shows the evolution of elongation in the process of re-tensioning described above.

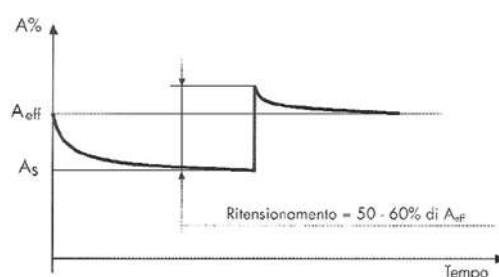

## POLYV BELTS

The ribbed belt combines high flexibility and lightness of flat belts and friction of V-belts, and thanks to the specific shape of the ribs ensures a high capacity of power transmission . The width of the belt can be adjusted changing the ribs number , in relation to the power to be transmitted. In this way you get a single belt which allows to optimize the dimensions. The vibrations are limited and the use of configurations in groups of belts is avoided. The PolyV belts are used in transmissions at high speed and with extremely small diameters of the pulleys

### General Features:

- Upper layer with textile reinforcement that supports very small pulley and allows an auxiliary drive on the back.
- High-strength cables, designed to transmit high power with low elongation .
- High-grip compound, grooved longitudinally, which develops a big contact area .
- Excellent resistance to mineral oils and temperatures between -30 ° C and +60 ° C (+80 ° C for short periods).
- Fit the pulleys profile H, J, K, L and M defined by the RMA IP-26, DIN 7867 and ASAE S 211.5.Norms

### Dimensional data:

TYPE		H	J	K	L	M
Pitch e	(mm)	1,60	2,34	3,56	4,70	9,40
Height h	(mm)	3,0	3,7	6,0	9,5	16,5
Weight	(gr/mt/rib)	5,9	9,2	20	30,9	124,1
Minim pulley diam	(mm)	13	20	40	75	180
DMinim. idler diam	(mm)	32	45	70	140	300

### Polyv belts code as follow :

**940 J** The number expresses the length (mm) measured at the top of the pulleys, in correspondence to the hollow part of the grooves of the belt, which is almost corresponding to the pitch length  $L_p$ . The letter corresponds to the pitch between two adjacent ribs

\* in any case size may be in tenths of inch



## POLYPOWER PJ

RPM small pulley	BASIC POWER IN W DATUM DIAMETER SMALL PULLEY											Belt speed m/s
	20	24	26	28	30	34	38	42	48	53	56	
100	3	5	6	7	8	9	11	13	16	18	19	10
300	7	12	15	17	20	25	30	34	42	48	51	
400	8	15	18	22	25	31	38	44	54	61	66	
500	10	18	22	26	30	38	46	54	65	75	80	
720	12	24	29	35	41	52	63	74	90	103	111	
870	13	27	34	40	47	60	73	86	105	121	130	
950	14	29	36	43	51	65	79	93	114	130	141	
1200	15	33	42	51	59	76	93	110	135	155	167	
1450	17	39	49	60	71	91	112	133	166	188	202	
1750	18	44	57	69	82	106	131	155	191	220	238	
2000	19	48	72	76	91	118	146	173	213	246	266	
2200	19	51	67	82	97	128	158	187	231	267	288	
2400	20	54	71	87	104	137	169	201	248	287	310	
2850	20	60	79	99	118	156	194	231	286	331	357	
3000	20	62	82	102	123	163	202	241	298	345	373	
3200	20	64	86	107	129	171	212	253	314	363	393	20
3450	19	67	90	113	136	181	225	269	334	386	417	
3800	19	70	95	121	145	194	243	290	360	417	451	
4200	18	74	101	129	156	209	262	314	390	451	488	
4800		79	110	140	171	231	289	347	432	500	541	
5400		83	117	151	185	251	315	379	471	546	590	
6000		86	124	161	197	270	340	409	509	590	637	
6600		89	129	170	209	287	363	437	544	630	680	
7000		90	133	175	217	298	377	456	566	655	706	
7500		91	137	181	225	311	395	476	592	684	737	
8000		92	140	187	233	324	411	495	618	711	766	30
8500		93	143	192	241	335	426	514	629	736	792	
9000		95	145	197	247	346	440	531	659	759	815	
10000		92	149	204	259	364	465	561	695	797	853	

Basic power for theoretical 25.000 hrs belt life.

Thanks to the teeth that individually fit in a pulley, **PI BELT** synchronous belts assures, a precise positioning in a drive systems, without skid. The limitation of the tension only to the useful efforts and the absence of device of lubrication, allow a simplification of the project of the transmission and his structure. These characteristics involve some notable savings in the costs of construction and maintenance.

**Construction:**

- Available in Imperial size MXL, XL, L, H, XH, XXH
- A hard wearing, flexible top surface protect tension cables
- Tension cables made in continuous helically glass fiber.
- Protective cover fabric with a low coefficient of friction ,in order to achieve minimum wear on the contact surfaces, and minimize noise
- Good resistance to oils and greases , and temperature between -25°C and + 100°C
- In line with ISO 5296 norm

RoHS and Reach certified

**Applications:**

Low tensioning , absence of skid, and great range of size and power, can help you to obtain compact drive and low costs of maintenance.

Application word of **PI BELT** timing belts include all industrials positive drivers, as machine tools, automatic lathe, piston pumps, compressors, mixing machines.

38 **TIMING BELTS CODE AS FOLLOW**

240 = Primitive length (inch)

H = Pitch

050 = Width code

	MXL	XL	L	H	XH	XXH
Tooth Pitch (mm)	2,032	5,08	9,525	12,7	22,23	31,75
Tooth Base (mm)	1,14	2,57	4,65	6,12	12,57	19,05
Tooth Depth (mm)	0,51	1,27	1,91	2,29	6,35	9,53
Overall belt height (mm)	1,15	2,3	3,6	4,3	11,2	15,7
Weight (gr/mt/inch)	12	59	87	110	300	420



## TIMING BELTS TOLERANCE

Table A - Width tolerance on MXL, XL, L,H belts

Belt width						Width tolerance (mm)		
LWidth in hundredths of inch from to		Leffective width				to 33" primitive length	up 33" to 66" primitive length	up 66" primitive length
		Inch from	mm to	from	to			
-	050	-	1/2"	-	12,7	+0,4 -0,8	+0,4 -0,8	
050	150	1/2"	1 "1/2	12,7	38,1	± 0,8	+0,8 -1,2	+0,8 -1,2
150	200	1 "1/2	2"	38,1	50,8	+0,8 -1,2	±1,2	+ 1,2 -1,6
200	300	2"	3"	50,8	76,2	+ 1,2 -1,6	±1,6	+ 1,6 -2,0

Width tolerance for all belts size XH e XXH is ± 4,8 mm for all size.

Table B -Belt length tolerance

Belt length inch from to		Tolerance mm	Belt length inch from to		Tolerance mm
-	10	±0,40	90	100	±1,00
10	15	±0,45	100	110	±1,05
15	20	±0,50	110	120	±1,10
20	30	±0,60	120	130	±1,15
30	40	±0,65	130	140	±1,20
40	50	±0,75	140	150	±1,25
50	60	±0,80	150	160	±1,30
60	70	±0,85	160	170	±1,35
70	80	±0,90	170	180	±1,40
80	90	±0,95			

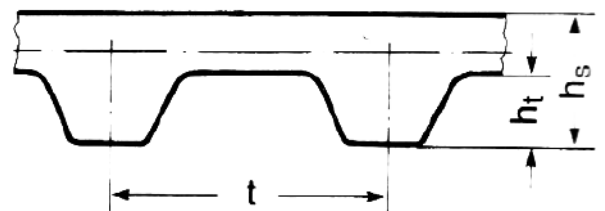

Table C - Overall belt height and tolerance.

Section	Overall height mm	tolerance mm
MXL	1,14	±0,6
XL	2,3	±0,6
L	3,6	±0,6
H	4,3	±0,6
XH	11,2	±0,6
XXH	15,7	±0,6

Section	t (mm)	t (")	hs (mm)	ht (mm)
MXL	2,032	2/25	1,14	0,51
XL	5,08	1/5	2,3	1,27
L	9,525	3/8	3,6	1,90
H	12,7	1/2	4,3	2,29
XH	22,225	7/8	11,2	6,35
XXH	31,75	1,1/4	15,7	9,53

## XL PITCH

Basic power in kW- BELT WIDTH COD 0,37 - 9,5 mm

RPM. speed	Teeth number small pulley											
	10	11	12	14	15	16	18	20	21	22	24	28
	Datum diameter in mm											
	16,17	17,79	19,4	22,64	24,26	25,87	29,11	32,34	33,96	35,57	38,81	45,28
100	0,003	0,003	0,003	0,006	0,006	0,006	0,008	0,008	0,008	0,008	0,011	0,011
200	0,008	0,008	0,011	0,011	0,011	0,014	0,014	0,017	0,017	0,020	0,020	0,022
300	0,011	0,014	0,014	0,020	0,020	0,020	0,022	0,025	0,028	0,028	0,028	0,036
400	0,017	0,020	0,020	0,022	0,025	0,028	0,028	0,034	0,036	0,036	0,039	0,048
500	0,020	0,022	0,025	0,028	0,031	0,034	0,036	0,042	0,045	0,045	0,050	0,062
600	0,025	0,028	0,028	0,036	0,036	0,039	0,045	0,050	0,053	0,056	0,062	0,070
700	0,028	0,031	0,036	0,042	0,045	0,048	0,053	0,059	0,062	0,064	0,070	0,084
800	0,034	0,036	0,039	0,048	0,050	0,053	0,062	0,070	0,070	0,076	0,084	0,095
900	0,036	0,042	0,045	0,053	0,056	0,062	0,070	0,078	0,081	0,084	0,092	0,106
1000	0,042	0,045	0,050	0,062	0,064	0,070	0,078	0,087	0,090	0,095	0,104	0,120
1100	0,045	0,053	0,053	0,064	0,070	0,076	0,084	0,095	0,098	0,104	0,112	0,132
1160	0,048	0,053	0,059	0,070	0,076	0,078	0,087	0,095	0,104	0,109	0,118	0,137
1200	0,050	0,056	0,062	0,070	0,078	0,081	0,092	0,104	0,109	0,112	0,123	0,143
1300	0,053	0,062	0,064	0,078	0,084	0,087	0,101	0,112	0,118	0,120	0,134	0,154
1400	0,059	0,064	0,070	0,084	0,090	0,095	0,109	0,120	0,126	0,132	0,143	0,168
1500	0,062	0,070	0,076	0,090	0,095	0,104	0,115	0,129	0,134	0,140	0,154	0,179
1160	0,070	0,076	0,084	0,095	0,104	0,112	0,123	0,134	0,143	0,151	0,165	0,190
1700	0,073	0,078	0,087	0,104	0,109	0,118	0,132	0,140	0,151	0,160	0,174	0,202
1750	0,076	0,081	0,090	0,104	0,112	0,120	0,134	0,151	0,157	0,165	0,179	0,210
1800	0,078	0,084	0,092	0,106	0,115	0,123	0,137	0,154	0,160	0,168	0,185	0,216
2000	0,087	0,095	0,104	0,120	0,129	0,134	0,154	0,171	0,179	0,188	0,204	0,241
2200	0,095	0,104	0,112	0,132	0,143	0,151	0,168	0,188	0,196	0,207	0,227	0,260
2400	0,104	0,112	0,123	0,143	0,154	0,165	0,185	0,204	0,216	0,224	0,246	0,286
2600	0,112	0,120	0,134	0,154	0,168	0,176	0,202	0,221	0,235	0,244	0,260	0,308
2800	0,120	0,132	0,143	0,168	0,179	0,193	0,216	0,241	0,252	0,263	0,286	0,333
3000	0,129	0,140	0,154	0,179	0,193	0,204	0,230	0,258	0,266	0,280	0,305	0,358
3200	0,134	0,151	0,165	0,190	0,204	0,218	0,246	0,272	0,286	0,300	0,325	0,378
3400	0,143	0,160	0,174	0,202	0,218	0,232	0,260	0,288	0,302	0,316	0,347	0,400
3500	0,151	0,165	0,179	0,210	0,224	0,241	0,266	0,297	0,311	0,328	0,358	0,414
3600	0,154	0,168	0,185	0,216	0,230	0,246	0,274	0,305	0,322	0,336	0,367	0,423
3800	0,162	0,174	0,193	0,227	0,244	0,260	0,291	0,322	0,339	0,356	0,384	0,445
4000	0,171	0,188	0,204	0,241	0,258	0,272	0,305	0,342	0,358	0,372	0,406	0,468
4200	0,179	0,196	0,216	0,252	0,266	0,286	0,319	0,358	0,372	0,389	0,423	0,490
4400	0,188	0,207	0,227	0,260	0,280	0,300	0,336	0,372	0,389	0,406	0,442	0,512
4600	0,196	0,216	0,235	0,274	0,291	0,314	0,350	0,389	0,406	0,426	0,462	0,532
4800	0,204	0,224	0,246	0,286	0,305	0,325	0,367	0,406	0,423	0,445	0,482	0,554
5000	0,213	0,235	0,258	0,297	0,316	0,342	0,381	0,420	0,440	0,459	0,498	0,574

BELT WIDTH 0,37 0,25  
 POWER FACTOR MULTIPLIER 1 0,54

MINIMUM TEETH IN MESH = 6

## L PITCH

Basic power in kW - BELT WIDTH COD. 100 - 25,4 mm

RPM. speed	Teeth number small pulley																				
	10	12	13	14	15	16	17	18	19	20	21	22	24	26	28	30	32	36	40	44	48
	Datum diameter in mm																				
	30,32	36,38	39,41	42,45	45,48	48,51	51,54	54,57	57,61	60,64	63,67	66,70	72,77	78,83	84,89	90,96	97,02	109,15	121,28	133,40	145,53
100	0,04	0,04	0,05	0,05	0,06	0,06	0,07	0,07	0,07	0,07	0,08	0,09	0,10	0,10	0,11	0,12	0,13	0,14	0,16	0,17	0,19
200	0,07	0,10	0,10	0,11	0,12	0,13	0,13	0,14	0,15	0,16	0,16	0,17	0,19	0,20	0,22	0,23	0,25	0,28	0,31	0,34	0,37
300	0,12	0,14	0,15	0,16	0,17	0,19	0,20	0,21	0,22	0,23	0,25	0,25	0,28	0,31	0,33	0,35	0,37	0,42	0,47	0,51	0,56
400	0,16	0,19	0,20	0,22	0,23	0,25	0,26	0,28	0,30	0,31	0,33	0,34	0,37	0,40	0,43	0,46	0,50	0,56	0,62	0,69	0,75
500	0,19	0,23	0,25	0,28	0,29	0,31	0,33	0,35	0,37	0,39	0,41	0,43	0,47	0,51	0,54	0,58	0,62	0,70	0,78	0,85	0,93
600	0,23	0,33	0,31	0,33	0,35	0,37	0,40	0,42	0,44	0,47	0,49	0,51	0,56	0,60	0,65	0,70	0,75	0,84	0,93	1,01	1,11
700	0,28	0,33	0,35	0,38	0,41	0,43	0,46	0,49	0,51	0,54	0,57	0,60	0,65	0,71	0,76	0,81	0,87	0,97	1,08	1,19	1,29
800	0,31	0,37	0,40	0,43	0,46	0,50	0,53	0,56	0,59	0,62	0,65	0,69	0,75	0,81	0,87	0,93	0,98	1,11	1,23	1,35	1,47
870	0,34	0,40	0,44	0,47	0,51	0,54	0,57	0,61	0,64	0,68	0,71	0,75	0,81	0,87	0,94	1,01	1,07	1,20	1,34	1,46	1,60
900	0,35	0,42	0,46	0,49	0,52	0,56	0,60	0,63	0,66	0,70	0,73	0,77	0,84	0,90	0,97	1,04	1,11	1,25	1,38	1,51	1,65
1000	0,39	0,46	0,51	0,54	0,58	0,62	0,66	0,70	0,74	0,78	0,81	0,85	0,93	1,00	1,08	1,16	1,23	1,38	1,53	1,68	1,82
1100	0,43	0,51	0,56	0,60	0,64	0,69	0,72	0,77	0,81	0,85	0,90	0,93	1,01	1,10	1,19	1,27	1,35	1,51	1,68	1,84	1,99
1160	0,45	0,54	0,59	0,63	0,68	0,72	0,77	0,81	0,85	0,90	0,94	0,98	1,07	1,16	1,25	1,34	1,42	1,60	1,76	1,93	2,10
1200	0,47	0,56	0,60	0,66	0,70	0,75	0,79	0,84	0,88	0,93	0,97	1,01	1,11	1,20	1,29	1,38	1,47	1,65	1,82	1,99	2,16
1300	0,51	0,60	0,66	0,71	0,75	0,81	0,86	0,90	0,95	1,00	1,05	1,10	1,20	1,30	1,40	1,49	1,59	1,78	1,96	2,15	2,33
1400	0,54	0,65	0,71	0,76	0,81	0,87	0,92	0,97	1,03	1,08	1,13	1,19	1,29	1,40	1,50	1,60	1,71	1,91	2,10	2,31	2,49
1500	0,58	0,70	0,76	0,81	0,87	0,93	0,98	1,04	1,10	1,16	1,21	1,27	1,38	1,49	1,60	1,72	1,82	2,04	2,25	2,45	2,65
1600	0,62	0,75	0,81	0,87	0,93	0,98	1,05	1,11	1,17	1,23	1,29	1,35	1,47	1,59	1,70	1,82	1,94	2,16	2,39	2,60	2,80
1700	0,66	0,79	0,86	0,92	0,98	1,05	1,11	1,18	1,24	1,31	1,37	1,43	1,56	1,69	1,81	1,93	2,05	2,29	2,52	2,75	2,96
1750	0,68	0,81	0,87	0,95	1,01	1,08	1,15	1,21	1,28	1,34	1,41	1,48	1,60	1,73	1,86	1,98	2,11	2,35	2,59	2,81	3,03
1800		0,84	0,90	0,97	1,04	1,11	1,18	1,25	1,31	1,38	1,45	1,51	1,65	1,78	1,91	2,04	2,16	2,41	2,65	2,88	3,10
1900		0,88	0,95	1,03	1,10	1,17	1,24	1,31	1,38	1,45	1,52	1,60	1,73	1,87	2,01	2,14	2,28	2,53	2,78	3,02	3,25
2000		0,93	1,01	1,08	1,16	1,23	1,31	1,38	1,45	1,53	1,60	1,68	1,82	1,96	2,10	2,25	2,38	2,66	2,90	3,16	3,39
2200		1,01	1,10	1,19	1,27	1,35	1,43	1,51	1,60	1,68	1,75	1,84	1,99	2,15	2,30	2,45	2,60	2,88	3,16	3,41	3,65
2400		1,11	1,20	1,29	1,38	1,47	1,56	1,65	1,73	1,82	1,91	1,99	2,16	2,33	2,49	2,66	2,80	3,11	3,39	3,65	3,89
2500		1,16	1,25	1,34	1,43	1,53	1,62	1,72	1,81	1,89	1,98	2,07	2,25	2,42	2,59	2,75	2,91	3,21	3,50	3,76	3,99
2600		1,20	1,30	1,40	1,49	1,59	1,69	1,78	1,87	1,96	2,06	2,15	2,33	2,51	2,68	2,84	3,01	3,31	3,60	3,86	4,09
2800		1,29	1,40	1,50	1,60	1,71	1,81	1,91	2,01	2,10	2,21	2,31	2,49	2,68	2,86	3,03	3,20	3,51	3,80	4,06	4,27
3000		1,38	1,49	1,60	1,71	1,82	1,93	2,04	2,14	2,25	2,35	2,45	2,65	2,84	3,03	3,21	3,39	3,71	3,99	4,24	4,43
3200			1,59	1,70	1,82	1,94	2,04	2,16	2,27	2,38	2,49	2,60	2,80	3,01	3,20	3,39	3,56	3,88	4,16	4,39	4,56
3400			1,69	1,81	1,92	2,05	2,17	2,29	2,40	2,51	2,63	2,74	2,96	3,16	3,36	3,55	3,72	4,04	4,31	4,51	4,65
3500			1,73	1,86	1,98	2,11	2,23	2,35	2,47	2,58	2,70	2,81	3,03	3,25	3,44	3,63	3,80	4,12	4,38	4,57	4,68
3600				1,90	2,04	2,16	2,29	2,41	2,53	2,65	2,77	2,88	3,10	3,32	3,52	3,71	3,89	4,19	4,44	4,61	4,71
3800				2,01	2,13	2,26	2,40	2,54	2,66	2,78	2,90	3,02	3,25	3,46	3,66	3,85	4,03	4,32	4,54	4,68	4,72
4000				2,11	2,24	2,39	2,51	2,66	2,78	2,90	3,03	3,16	3,39	3,60	3,80	3,98	4,16	4,43	4,63	4,72	4,71
4200					2,35	2,49	2,63	2,78	2,89	3,03	3,16	3,28	3,52	3,74	3,94	4,12	4,28	4,54	4,68	4,74	4,65
4400					2,45	2,60	2,74	2,88	3,01	3,15	3,28	3,41	3,65	3,87	4,06	4,24	4,39	4,61	4,72	4,71	4,54

BELT WITH 100 0,75 0,50  
 POWER FACTOR MULTIPLIER 1 0,71 0,42

MIMMUN TEETH IN MESH = 6

## H PITCH

Basic power in kW - BELT WIDTH COD. 100 - 25,4 mm

RPM. speed	Teeth number small pulley																
	14	16	17	18	19	20	21	22	24	26	28	30	32	36	40	44	48
	Datum diameter in mm																
	56,60	64,68	68,72	72,77	76,81	80,85	84,89	88,94	97,02	105,11	113,19	121,28	129,36	145,53	161,70	177,87	194,04
100	0,19	0,21	0,22	0,24	0,25	0,26	0,28	0,29	0,31	0,34	0,37	0,40	0,43	0,48	0,53	0,58	0,63
200	0,37	0,43	0,45	0,48	0,50	0,53	0,55	0,58	0,63	0,69	0,74	0,79	0,84	0,95	1,05	1,16	1,27
300	0,55	0,63	0,67	0,72	0,75	0,79	0,83	0,87	0,95	1,03	1,11	1,19	1,27	1,42	1,58	1,74	1,89
400	0,74	0,84	0,90	0,95	1,00	1,05	1,11	1,16	1,27	1,37	1,48	1,58	1,69	1,89	2,10	2,31	2,52
500	0,93	1,05	1,12	1,19	1,25	1,32	1,39	1,45	1,58	1,72	1,84	1,98	2,10	2,36	2,63	2,89	3,15
600	1,11	1,27	1,34	1,42	1,51	1,58	1,66	1,74	1,89	2,05	2,21	2,36	2,52	2,83	3,15	3,46	3,77
700	1,29	1,48	1,57	1,66	1,75	1,84	1,93	2,03	2,21	2,39	2,57	2,76	2,94	3,30	3,66	4,03	4,39
800	1,48	1,69	1,79	1,89	2,00	2,10	2,21	2,31	2,52	2,73	2,94	3,15	3,36	3,77	4,18	4,59	4,99
870	1,60	1,84	1,95	2,06	2,17	2,29	2,40	2,51	2,75	2,97	3,19	3,42	3,65	4,10	4,54	4,98	5,42
900	1,66	1,89	2,01	2,13	2,25	2,36	2,48	2,60	2,83	3,07	3,30	3,54	3,77	4,23	4,69	5,14	5,59
1000	1,84	2,10	2,24	2,36	2,50	2,63	2,76	2,89	3,15	3,41	3,66	3,92	4,18	4,69	5,19	5,69	6,19
1100	2,03	2,31	2,46	2,60	2,75	2,89	3,03	3,18	3,46	3,74	4,03	4,30	4,59	5,15	5,69	6,24	6,77
1160	2,13	2,44	2,59	2,75	2,89	3,04	3,19	3,34	3,65	3,94	4,24	4,54	4,83	5,42	5,99	6,56	7,12
1200		2,52	2,68	2,83	2,99	3,15	3,30	3,46	3,77	4,07	4,39	4,69	4,99	5,59	6,19	6,70	7,36
1300		2,73	2,90	3,07	3,24	3,41	3,57	3,74	4,07	4,41	4,74	5,07	5,39	6,04	6,68	7,30	7,92
1400		2,94	3,13	3,30	3,48	3,66	3,84	4,02	4,38	4,74	5,10	5,45	5,80	6,48	7,16	7,83	8,47
1500		3,15	3,34	3,54	3,73	3,92	4,11	4,30	4,68	5,07	5,45	5,82	6,19	6,92	7,64	8,34	9,02
1600		3,36	3,57	3,77	3,98	4,18	4,38	4,59	4,99	5,39	5,80	6,19	6,58	7,36	8,11	8,84	9,55
1700		3,56	3,78	4,00	4,21	4,43	4,65	4,86	5,30	5,72	6,14	6,56	6,97	7,78	8,57	9,33	10,07
1750		3,66	3,89	4,12	4,33	4,56	4,78	5,01	5,45	5,88	6,31	6,74	7,16	7,99	8,80	9,58	10,32
1800		3,77	4,00	4,23	4,46	4,68	4,92	5,14	5,59	6,04	6,48	6,92	7,36	8,20	9,02	9,81	10,58
1900		4,04	4,22	4,46	4,70	4,94	5,18	5,42	5,89	6,36	6,83	7,28	7,73	8,62	9,47	10,28	11,06
2000		4,18	4,44	4,68	4,94	5,19	5,45	5,69	6,18	6,68	7,16	7,64	8,11	9,03	9,90	10,74	11,53
2100				4,92	5,18	5,44	5,71	5,97	6,48	6,99	7,50	7,99	8,47	9,42	10,32	11,18	12,00
2200				5,14	5,42	5,69	5,97	6,24	6,77	7,30	7,83	8,34	8,84	9,82	10,74	11,62	12,43
2300				5,37	5,65	5,94	6,22	6,51	7,06	7,62	8,15	8,68	9,20	10,21	11,15	12,03	12,85
2400				5,59	5,89	6,18	6,48	6,77	7,35	7,92	8,48	9,02	9,55	10,58	11,53	12,43	13,25
2500				5,82	6,12	6,43	6,74	7,04	7,63	8,22	8,80	9,35	9,90	10,95	11,92	12,82	13,63
2600				6,04	6,36	6,68	6,99	7,30	7,92	8,52	9,12	9,68	10,24	11,31	12,29	13,18	13,99
2800				6,48	6,82	7,15	7,49	7,83	8,47	9,11	9,74	10,32	10,90	12,00	12,99	13,88	14,64
3000				6,92	7,27	7,63	7,98	8,34	9,01	9,68	10,33	10,94	11,53	12,65	13,63	14,49	15,20
3200				7,35	7,73	8,09	8,47	8,84	9,54	10,24	10,91	11,53	12,14	13,26	14,22	15,02	15,66
3400				7,78	8,17	8,56	8,94	9,33	10,06	10,78	11,47	12,10	12,70	13,82	14,74	15,48	16,01
3500				7,99	8,39	8,78	9,18	9,58	10,31	11,04	11,74	12,38	12,98	14,09	14,98	15,67	16,14
3600						9,00	9,41	9,82	10,56	11,30	12,00	12,64	13,24	14,34	15,20	15,85	16,24
3800						9,45	9,87	10,29	11,05	11,80	12,52	13,15	13,74	14,81	15,58	16,11	16,35
4000						9,88	10,31	10,74	11,52	12,28	13,00	13,63	14,20	15,22	15,90	16,29	16,34
4200						10,30	10,75	11,19	11,97	12,74	13,47	14,08	14,63	15,58	16,13	16,36	16,19
4400						10,71	11,17	11,62	12,41	13,18	13,89	14,49	15,01	15,87	16,29	16,32	15,90
4600						11,12	11,58	12,03	12,82	13,59	14,29	14,85	15,35	16,10	16,35	16,17	15,46
4800						11,50	11,97	12,44	13,21	13,98	14,67	15,20	15,64	16,27	16,33	15,89	14,87
5000						11,88	12,35	12,82	13,59	14,35	15,01	15,49	15,88	16,37	16,21	15,49	

BELT WIDTH 300 200 150 100 0,75

POWER FACTOR MULTIPLIER 3,36 2,14 1,56 1 0,71

MINIMUM TEETH IN MESH = 6

## XH PITCH

Basic power in kW - BELT WIDTH COD. 100 - 25,4 mm

RPM. speed	Teeth number small pulley								
	18	20	22	24	26	28	30	32	40
	Datum diameter in mm								
	127,34	141,49	155,64	169,79	183,94	198,08	212,23	226,38	282,98
100	0,57	0,63	0,69	0,75	0,83	0,88	0,94	1,00	1,25
200	1,13	1,25	1,38	1,51	1,63	1,76	1,88	2,01	2,51
300	1,70	1,88	2,07	2,26	2,45	2,64	2,82	3,01	3,74
400	2,26	2,51	2,76	3,01	3,26	3,51	3,74	4,00	4,97
480	2,71	3,01	3,30	3,60	3,89	4,19	4,48	4,77	5,93
500	2,82	3,13	3,44	3,74	4,06	4,36	4,67	5,01	6,16
510	2,88	3,20	3,51	3,82	4,13	4,45	4,75	5,07	6,28
570	3,21	3,56	3,92	4,27	4,60	4,96	5,30	5,64	6,98
600	3,38	3,74	4,12	4,48	4,85	5,21	5,57	5,93	7,33
680	3,82	4,24	4,66	5,07	5,48	5,88	6,28	6,68	8,24
700	3,93	4,36	4,79	5,21	5,62	6,04	6,46	6,87	8,47
800	4,48	4,96	5,45	5,93	6,41	6,87	7,33	7,79	9,55
870	4,86	5,39	5,91	6,42	6,93	7,44	7,93	8,42	10,29
900	5,03	5,57	6,11	6,64	7,15	7,68	8,18	8,68	10,58
1000	5,57	6,16	6,75	7,33	7,90	8,47	9,01	9,55	11,57
1100	6,11	6,75	7,39	8,02	8,62	9,24	9,81	10,38	12,49
1160	6,42	7,09	7,77	8,42	9,05	9,68	10,29	10,87	13,01
1200		7,33	8,02	8,68	9,33	9,97	10,66	11,18	13,35
1300		7,90	8,63	9,33	10,03	10,68	11,32	11,94	14,13
1400		8,47	9,23	9,97	10,68	11,38	12,04	12,67	14,82
1500		9,01	9,81	10,59	11,32	12,04	12,70	13,35	15,45
1600		9,55	10,38	11,18	11,94	12,67	12,79	14,04	15,98
1700		10,07	10,94	11,76	12,53	13,26	13,94	14,55	16,40
1750		10,33	11,21	12,04	12,81	13,55	14,22	14,82	16,58
1800			11,47	12,32	13,10	13,82	14,49	15,08	16,67
1900			11,99	12,85	13,91	14,35	15,43	15,56	16,93
2000			12,49	13,35	14,13	14,82	15,45	15,98	17,04
2100			12,97	13,82	14,59	15,28	15,85	16,32	17,02
2200			13,43	14,49	15,02	15,67	16,20	16,61	16,87
2300			13,87	14,70	15,42	16,02	16,49	16,82	16,64
2400			14,27	15,08	15,77	16,32	16,73	16,97	16,15
2500				15,45	16,09	16,58	16,89	17,04	15,58
2600				15,77	16,37	16,78	17,01	17,02	14,86
2800				16,33	16,78	17,02	17,02	16,76	
3000				16,73	17,01	17,02	16,74	16,15	
3200				16,97	17,02	16,76	16,15	15,17	
3400				17,04	16,84	16,25	15,23	13,79	

BELT WIDTH                      400      300      200  
 POWER FACTOR MULTIPLIER   4,76      3,36      2,14

MINIMUM TEETH IN MESH = 6

HTD means **High Torque Drive**, and HTD profile offer a lot of advantage: more precise positioning with a minimum of friction in a drive systems, no skid. Compared to the standard inch timing belts, **PI BELT** HTD timing belts offer more power. These characteristics involve some notable savings in the costs of construction and maintenance

**Construction:**

- Available in metric size 3M, 5M, 8M, 14M. 2M and 20M on demand
- A hard wearing, flexible top surface protect tension cables
- Tension cables made in continuous helically glass fiber.
- Protective cover fabric with a low coefficient of friction, in order to achieve minimum wear on the contact surfaces, and minimize noise
- Good resistance to oils and greases, and temperature between -25°C and + 100°C
- In line with ISO 5296 norm

RoHS and Reach certified

**Applications**

Low tensioning, absence of skid, and great range of size and power, can help you to obtain compact drive and low costs of maintenance. Application word of PIBELT timing belts include all industrials positive drivers, as machine tools, automatic lathe, piston pumps, compressors, mixing machines.

**TIMING BELTS CODE AS FOLLOW**

- 1040 = Primitive length (mm)
- 8M = Pitch (mm)
- 50 = Width code

	<b>3M</b>	<b>5M</b>	<b>8M</b>	<b>14M</b>
<b>Tooth Pitch (mm)</b>	3	5	8	14
<b>Tooth Depth (mm)</b>	1,20	2,1	3,4	6,1
<b>Overall belt height (mm)</b>	2,40	3,6	5,6	10
<b>Weight (gr/mt/10 mm)</b>	29	40	64	98

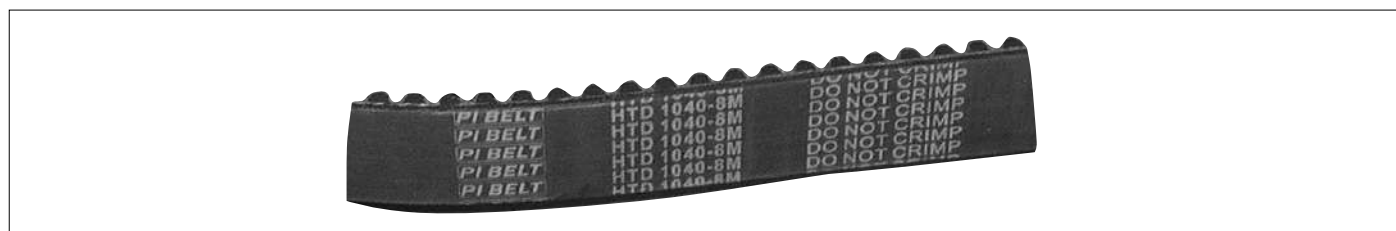

## TOLERANCE HTD BELTS

Table A : tolerance in width

Width in mm		Width tolerance (mm)		
from	to	till a 800 mm of pitch length	from 800 to 1760 mm of pitch length	over 1760 mm of pitch length
-	9	+ 0,4 - 0,8	+ 0,4 - 0,8	-- --
9	40	± 0,8	± 0,8	+ 0,8
40	50	+ 0,8 - 1,2	+ 1,2 - 1,2	+ 1,2 - 1,5
50	85	± 1,2	± 1,5	+ 1,5
85	170	± 1,5	+ 1,5 - 2	± 2
> 170			± 4,8	± 4,8

Table A : tolerance in length

Lenght in mm		Tolerance mm	Lenght in mm		Tolerance mm
from	to		from	to	
	250	± 0,40	2250	2500	± 1,00
250	380	± 0,45	2500	2750	± 1,05
380	500	± 0,50	2750	3000	± 1,10
500	750	± 0,60	3000	3250	± 1,15
750	950	± 0,65	3250	3500	± 1,20
950	1250	± 0,75	3500	3750	± 1,25
1250	1500	± 0,80	3750	4000	± 1,30
1500	1750	± 0,85	4000	4250	± 1,35
1750	2000	± 0,90	4250	4500	± 1,40
2000	2250	± 0,95	4500	5000	± 1,50

Table C : tolerance in height.

Pitch	Tooth height mm	tolerance mm
3M	2,4	±0,2
5M	3,6	±0,25
8M	5,6	±0,4
14M	10,0	±0,6
20M	13,2	±0,8

Belts data

Size	pitch (mm)	overall height (mm)	tooth depth (mm)
3M	3	2,4	1,2
5M	5	3,6	2,1
8M	8	5,6	3,4
14 M	14	10,0	6,1
20M	20	13,2	9,0

## HTD 8M

Basic power in kW - BELT WIDTH 20 mm

RPM. speed	Teeth number small pulley														
	22	24	26	28	30	32	34	36	38	40	44	48	56	64	72
	Datum diameter in mm														
	56,02	61,12	66,21	71,30	76,39	81,49	86,58	91,67	96,77	101,86	112,05	122,23	142,60	162,97	183,35
10	0,02	0,02	0,02	0,03	0,03	0,04	0,04	0,05	0,05	0,06	0,06	0,07	0,08	0,09	0,10
20	0,03	0,04	0,04	0,05	0,06	0,07	0,08	0,09	0,11	0,11	0,12	0,14	0,16	0,18	0,20
50	0,08	0,09	0,11	0,13	0,16	0,18	0,21	0,23	0,27	0,28	0,31	0,34	0,40	0,45	0,51
100	0,16	0,19	0,22	0,27	0,31	0,36	0,41	0,47	0,54	0,56	0,62	0,68	0,79	0,90	1,02
200	0,33	0,37	0,45	0,53	0,62	0,72	0,82	0,93	1,05	1,13	1,24	1,34	1,54	1,73	1,93
300	0,49	0,53	0,65	0,77	0,90	1,04	1,19	1,34	1,51	1,64	1,78	1,93	2,21	2,50	2,77
400	0,65	0,71	0,84	0,99	1,16	1,34	1,54	1,74	1,96	2,12	2,31	2,50	2,87	3,23	3,59
500	0,81	0,89	1,02	1,21	1,42	1,64	1,88	2,13	2,40	2,59	2,82	3,05	3,50	3,94	4,37
600	0,98	1,07	1,21	1,43	1,68	1,94	2,21	2,51	2,82	3,05	3,32	3,59	4,11	4,63	5,13
730	1,19	1,30	1,44	1,71	2,00	2,31	2,64	2,98	3,36	3,63	3,95	4,27	4,89	5,50	6,09
800	1,30	1,42	1,56	1,85	2,17	2,50	2,86	3,24	3,64	3,94	4,28	4,63	5,30	5,95	6,60
870	1,42	1,54	1,68	1,99	2,34	2,70	3,08	3,49	3,93	4,24	4,61	4,98	5,70	6,41	7,09
970	1,58	1,72	1,86	2,20	2,57	2,97	3,39	3,84	4,32	4,67	5,08	5,48	6,27	7,04	7,79
1000	1,63	1,77	1,92	2,26	2,64	3,05	3,49	3,95	4,44	4,80	5,22	5,63	6,44	7,23	7,99
1170	1,90	2,07	2,25	2,59	3,04	3,51	4,00	4,53	5,10	5,51	5,98	6,45	7,37	8,26	9,13
1200	1,95	2,13	2,30	2,65	3,11	3,59	4,09	4,63	5,21	5,63	6,12	6,60	7,53	8,44	9,32
1460	2,37	2,58	2,80	3,15	3,69	4,26	4,86	5,50	6,19	6,68	7,25	7,81	8,90	9,95	10,95
1600	2,60	2,83	3,06	3,41	4,00	4,61	5,26	5,95	6,70	7,23	7,84	8,44	9,61	10,72	11,79
1750	2,84	3,09	3,34	3,69	4,32	4,98	5,69	6,43	7,23	7,80	8,46	9,10	10,35	11,53	12,64
2000	3,24	3,52	3,81	4,18	4,85	5,59	6,37	7,21	8,11	8,74	9,47	10,17	11,53	12,80	13,99
2500	4,03	4,38	4,74	5,19	5,86	6,75	7,69	8,69	9,77	10,52	11,36	12,17	13,70	15,08	16,3
2920	4,68	5,09	5,50	6,02	6,66	7,66	8,73	9,86	11,08	11,92	12,84	13,71	15,31	16,71	17,89
3500					7,71	8,85	10,07	11,36	12,75	13,70	14,68	15,60	17,20	18,47	
4000						9,79	11,13	12,55	14,07	15,08	16,09	16,99	18,47		
4500							12,10	13,62	15,26	16,32	17,30	18,14			
5000								14,57	16,30	17,40	18,31	19,04			
5500									17,20	18,31	19,10				
6000									17,95	19,04	19,65				

Belt width	20	30	50	85
Width factor	1,00	1,58	2,74	4,76

### Length factor

Datum length (mm)	480-800	800-1120	1120-1760	1760-2800
Length multiplier (mm)	0,8	0,9	1,0	1,1

MINIMUM TEETH IN MESH = 6

## HTD 14M

Basic power in kW - BELT WIDTH 40 mm

RPM. speed	Teeth number small pulley																
	28	29	30	32	34	36	38	40	44	48	52	56	60	64	68	72	80
	Datum diameter in mm																
	124,8	129,2	133,7	142,6	151,5	160,4	169,3	178,2	196,1	213,9	231,7	249,5	267,4	285,2	303,0	320,9	356,5
10	0,2	0,2	0,2	0,2	0,3	0,3	0,3	0,4	0,4	0,4	0,5	0,5'	0,6	0,6	0,6	0,7	0,8
20	0,4	0,4	0,4	0,5	0,6	0,6	0,7	0,7	0,8	0,9	1,0	1,1	1,1	1,2	1,3	1,4	1,5
40	0,7	0,8	0,8	1,0	1,1	1,2	1,4	1,4	1,6	1,8	1,9	2,1	2,3	2,4	2,6	2,7	3,0
60	1,1	1,2	1,3	1,5	1,7	1,9	2,0	2,2	2,4	2,7	2,9	3,2	3,4	3,6	3,8	4,1	4,5
100	1,8	1,9	2,1	2,4	2,8	3,1	3,4	3,6	4,0	4,4	4,9	5,2	5,6	6,0	6,4	6,7	7,5
200	3,6	3,9	4,2	4,8	5,5	6,2	6,8	7/2	8,0	8,9	9,7	10,5	11/2	12/0	12,7	13,5	15,0
300	4,9	5,3	5,7	6,6	7,5	8,5	9,2	9,7	10,8	12,0	13,1	14,2	15,3	16,5	17,7	18,9	21,3
400	6,1	6,6	7,1	8,2	9,3	10,5	11,3	12,0	13,3	14,7	16,1	17,4	18,7	20,1	21,5	22,9	25,8
500	7,2	7,8	8,4	9,6	11,0	12/3	13,3	14,1	15,6	17,2	18,7	20,2	21,7	23,3	24,8	26,4	29,6
600	8,2	8,9	9,5	11,0	12,5	14,0	15,1	15,9	17,6	19,4	21,1	22,7	24,4	26,1	27,8	29,5	32,9
730	9,4	10,2	10,9	12,6	14,2	16,0	17,2	18,2	20,0	22,0	23,8	25,6	27,4	29,3	31,1	32,9	36,5
800	10,0	10,8	11,6	13,4	15,1	17,0	18,3	19,3	21,2	23,2	25,2	27,0	28,9	30,8	32,6	34,5	38,2
870	10,6	11,4	12,3	14,1	16,0	17,9	19/3	20,3	22,4	24,4	26,4	28,3	30,2	32/2	34,0	36,0	39,7
970	11,4	12,3	13,2	15/1	17,1	19,2	20,6	21,7	23,8	26,0	28,0	30,0	32,0	33,9	35/8	37,7	41,4
1000	11,6	12,5	13,5	15,4	17,5	19/6	21,0	22,1	24,3	26,5	28,5	30,5	32,5	34,4	36,3	38,2	41,9
1160	12,8	13,8	14,8	16,9	19,1	21,4	22,9	24,1	26,3	28,6	30,7	32,7	34,7	36,7	38,5	40,3	43,7
1200	13,1	14,1	15,1	17,3	19,5	21,8	23,4	24/5	26,8	29,1	31,2	33,2	35,2	37/1	38,9	40,7	44,1
1460	14,7	15/8	16,9	19,3	21,8	24,3	25,9	27,1	29,5	31/8	33,8	35,7	37,5	39,3	40/8	42,3	44,7
1600	15,4	16,6	17,8	20,3	22,8	25,4	27,1	28,3	30,6	32,9	34,8	36,6	38,3	39,8	41,1	42,3	44,0
1750	16,2	17,4	18,6	21,2	23,8	26,5	28,2	29,4	31,6	33,8	35,6	37,2	38,6	39,9	40,8	41,6	42,5
2000	17,3	18,5	19/8	22,5	25,2	28,0	29/6	30,8	32,8	34,7	36,2	37/3	38/2	38,9	39,1		
2500	20,8	21,4	22,0	24,2	26,9	29,7	31,2	32/0	33,4	34,4	34,7	34,4					
2920	23,6	24,2	24,8	26,0	27,4	30,0	31,1	31,6	31,9	31,7							
3500			28,1	29,1	30,0	30,7	31,2	31,6									
4000				30,9	31,4												

Belt width	40	55	85	115	170
Width factor	1,0	1,5	2,50	3,48	5,29

### Length factor

Datum length (mm)	966-1190	1190-1610	1778-2100	2100-2590	2590-3500	3500-oltre
Length multiplier (mm)	0,8	0,9	0,95	1/0	1,05	1,1

MINIMUM TEETH IN MESH = 6

## SAFETY FACTORS

A proper choice of the safety factor ensures the operation of the V-belts. The following table lists the most common working machinery with safety coefficients recommended

**Table 2 : Value of safety factor**

	-AC electric motors a low starting "			-AC electric motors a medium starting		
	- CC electric motors a low starting			-CC electric motors a low starting		
	-Internal combustion engines with 4 or more cylinders			-Internal combustion engines with 4 or more cylinders		
	-Water and steam turbines			-Water and steam turbines		
	Daily Service			Daily Service		
	Up to 10 hrs	10/16 hrs	16/24 hrs	Up to 10 hrs	10/16 hrs	16/24 hrs
Centrifugal pumps up to 7,5 Kw Blowers and exhausters Compressors Light-duty conveyors Fans up to 7,5 Kw	1,0	1,2	1,4	1,2	1,4	1,6
Pumps over 7,5 Kw Revolving and vibrating screens Dough mixers Rotary compressors Medium -duty conveyors Fans over to 7,5 Kw Generators Printing machinery Machine tools	1,3	1,5	1,7	1,6	1,8	2
Piston pumps Brick machinery Paper mill beaters Saw mill and woodworking Bucket elevators Hammer mills Exciters Conveyors ( drag-pan-screw ) Piston compressors	1,5	1,7	1,9	1,9	2,1	2,3
Crusher (gyratory-jaw-roll ) Mills ( ball-rod-tube) Rubber extruders -calenders	1,7	1,9	2,1	2,1	2,3	2,5

**PI BELT** Double Side Timing Belts , in inch or HTD size, are ideal belts for serpentine drives, with one or more reverse bends that require power to be transmitted from both sides of the belt.

**Construction:**

- Available in imperial and metric size L, H, 8M, 14M
- A hard wearing, flexible top surface protect tension cables
- Tension cables made in continuous helically glass fiber.
- Protective cover fabric with a low coefficient of friction ,in order to achieve minimum wear on the contact surfaces, and minimize noise
- Good resistance to oils and greases , and temperature between -25°C and + 100°C
- Power transmission and tolerance data are the same of single side belts

RoHS and Reach certified

**Applications**

Low tensioning , absence of skid, and great range of size and power, can help you to obtain compact drive and low costs of maintenance. Application word of **PI BELT** Double Side Timing Belts include all industrials positive drivers that need a serpentine drives or pulley working on a both side of belts

**TIMING BELTS CODE AS FOLLOW**

- 240 = Primitive length (mm)
- L = Pitch (mm)
- DD = Double Side code
- 050 = Width code

	L	H	8M	14M
Tooth Pitch (mm)	9,525	12,7	8	14
Overall belt height (mm)	4,50	5,8	8,3	14,9



## DATA SHEET

Company: ..... Address: .....  
 Contact: ..... Email .....  
 Phone N: ..... Fax: .....  
 Type of machine: .....  
 Request date: ..... Rife. N° .....

**1. Dimensional features**  
 Total number of di pulley / hidler: .  
 Material: .....

**DESIGN**

Pulley	Intern/external	Fix/mobile	Ø bore	Datum Diam	Coordinates (mm)	
					x	y
DRIVER						
Hidler / Pulley						
Hidler / Pulley						
Hidler / Pulley						
Driven						

Drawing n°: ..... Pls attach a drawing of transmission.

**2. Mechanical features:**  
 Driver speed: ..... RPM  
 Max power: .....kW      Absorbed power: .....kW  
 OR :  
 Max torque: ..... Nm      Driven speed: .....RPM  
 N° start / day: .....  
 Hrs service: ...../ day

**3. Operating conditions:**  
 Medium temperature: ..... °C      Max temperature: ..... °C  
 umidity       salt      dust      chemical products       ozo  
other: .....

**4. Type of belt:**  
 Size: ..... Quantity: .....

**5. Fitting data:**  
 Adjustment mechanism: ..... Values: .....  
 Note: .....



sede centrale



magazzino 2



www.pizzirani.net



53034 Colle di Val D'Elsa (Si) Loc. San Marziale tel. +39.0577.909047 fax commerciale 0577.909049 fax acquisti 0577.908900 info@pizzirani.net  
Informazioni tecniche, calcoli, preconizzazioni. - tecnica@pizzirani.net

distributore di zona:  
area dealer: