

# Freewheel Clutches

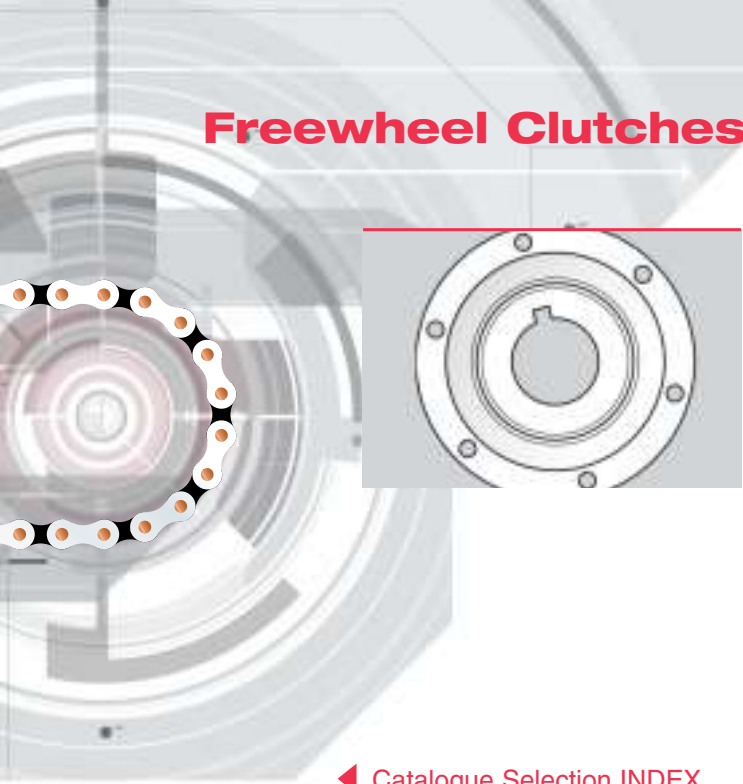

◀ [Catalogue Selection INDEX](#)

◀ [Enquiry](#)

◀ [CD Contents](#)

## Index

Freewheels - their Functions and Applications	2	▶
Freewheel Types	4-5	▶
Backstop Elements - B200 & B500	10	▶
Backstops:		
- CR	21	▶
- CR/BV	20	▶
- CR/BW	20	▶
- RSBF	21	▶
Combined Sprag and Bearing Units:		
- CKK & CSK	8	▶
- GFK	17	▶
Contact Free Clutches:		
- RAZ & RIZ	21	▶
- RSBI & RBI	21	▶
Couplings - AGF	16	▶
Keyseated Outer Race Clutch - AGFN	13-14	▶
Index Clutches - HT	7	▶
Miniature Freewheels - KI	17	▶
Ratchet Freewheels - IRF	19	▶
Roller Ramp Clutches:		
- AA	12	▶
- AEF	12	▶
- ANF	12	▶
- ANR	12	▶
- CNAS	11	▶
- CNFS	11	▶
Roller Ramp Clutch with Bearing - ASK	17	▶
Roller Ramp Clutch - AGF Self Contained	13-15	▶
Single Rev Clutches:		
- BAT	18	▶
- CTK	18	▶
Sprag Clutches:		
- M Series	5-6	▶
- PB	7	▶
Sprag Elements - BW	9-10	▶

# Freewheels - Their Functions and Applications



Freewheels are precision clutches which positively lock to transmit torque in one direction of rotation, but are totally released in the opposite direction, as in the sketches alongside of a roller-ramp system. Original types of freewheels (also referred to as One-Way clutches) were based on the ratchet and pawl principle, of which the Cross IRF clutches are a direct development, and these often provide the simplest and lowest cost solutions for many applications. Modern demands of high speeds, quiet operation, and high accuracy of control have led to the development of an extensive range of sprag, roller ramp, and contact-free element clutches, to provide the designer with a wide selection of options for uni-directional drive. Freewheels are used for three basic functions of transmission; overrunning, indexing and backstopping.

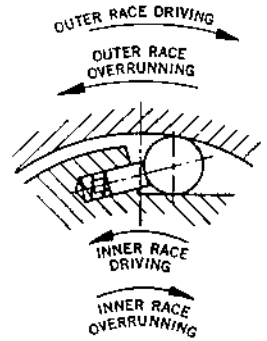

## Overrunning



In this mode of operation the output can rotate faster than the input or continue to rotate if the input is stopped. Should the input drive be reversed there will be no drive to the output. This is typically used in starter drives for engines or turbines to provide automatic decoupling of starter motor drive when operational speed is reached; on bi-motor drives; and also to overcome the problems of backdrive when high inertia, high speed drives are shut down.

## Indexing



In this mode reciprocating motion applied to the driving race of the clutch is transformed into uni-directional intermittent motion of the driven race. This function is typically used for indexing of conveyors, packaging materials and sheet steel in presses. The intermittent movement can also be used as a means of obtaining slow rotational speeds for products such as inking rollers.

## Backstopping



The object of backstop clutches is to prevent reverse rotation of the drive shafts, which otherwise would cause damage to the machinery. Backstopping is achieved simply by anchoring one race of the clutch so that the other race is free to rotate in one direction, but is immediately locked in reverse. These are typically used on conveyors, elevators, cranes and pumps.

## Typical Industries in which Freewheels are used.

- Agricultural Machinery
- Business Machines
- Conveyors
- Cranes and Hoists
- Dry Cleaning Machines
- Fans
- Food Processing Machines
- Machine Tools
- Packaging Machinery
- Printing Machines
- Pumps and Compressors
- Textile Machinery
- Two Speed Drives
- Washing Machines
- Wire Winding Machinery

# Freewheel Types

Freewheels are directional couplings where the driving member positively rotates the driven member in one direction, but automatically disengages itself if the direction of rotation is reversed or if the driven member rotates faster than the driver. Thus two modes of operation exist; transmission of torque, or overrunning (idling).

As already described freewheels are used for three types of operation:-

**Overrunning:** Where the freewheel disengages automatically when the driven member rotates faster than the driving member, used in:-

- Dual Drives - Prevents disconnected engine/motor from being driven.
- Conveyor Belts - Goods may be moved faster on the belt than the corresponding drive speed.
- Crawler Drives - The slow running engine/motor is automatically disengaged from the fast running engine.
- Disengaging of large centrifugal mass from the drive. The centrifugal mass can run on freely when the drive is stopped.

**Backstops:** Where the freewheel allows rotation in one direction only. It overruns continuously during normal operation, but prevents reverse rotation if the system is disconnected, used in:-

- Inclined Conveyors and Elevators
- Pumps and Compressors
- Gear Drives

**Indexing:** Where the freewheel converts reciprocating motion into intermittent unidirectional drive, used for feeding of components in:-

- |                   |   |                      |
|-------------------|---|----------------------|
| Metal Stamping    | • | Machine Tools        |
| Packing Machines  | • | Inspection Equipment |
| Printing Machines | • | Assembly Equipment   |

There are four basic types of freewheel available; Industrial Ratchet Freewheels, Sprag Clutches, Roller Ramp Clutches, and Contact Free Element Sprag Clutches. Various models within these basic types, such as combination with bearings, addition of flange covers and flexible couplings provide an extensive range of possibilities for the designer.

## Industrial Ratchet Freewheels

The Industrial Ratchet Freewheel (I.R.F) is the most basic yet most robust freewheel type. The most common usage of the IRF's is in combination with a roller chain sprocket. The clutch consists of five component parts; the inner race or centre (1), the outer race (2), driving pawls (3), actuating springs (4) and support bearing balls (5).

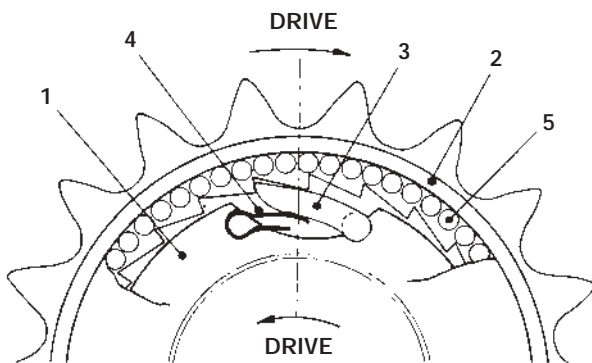

Torque is transmitted from one race to the other by the pawls (3) engaging in the ratchet teeth formed on the inside of the outer race. If the races are rotated in the opposite direction the pawls are able to run free down the length of the ratchet teeth. The pawls are maintained in contact with the ratchet teeth at all times by robust leaf springs (4) so ensuring positive drive is always available. Inner and outer races are maintained concentric to one another by the light duty ball bearing race (5).

IRF's provide a compact, high torque, low cost solution for many applications where low shaft speeds are involved (150 rpm max). They are ideal for overrunning applications involving long periods in drive mode, as no wear takes place due to torsionals etc., whilst transmitting torque. They are unsuitable for backstop applications. For detailed information on IRF Freewheels refer to page 19.

## Sprag Clutches

Sprag Clutches consist of plain diameter concentric inner and outer races with individual spring loaded sprags between. A light spring ensures that the sprags always maintain contact with the races. Torque is transmitted by the wedging action of the sprags between the races.

OUTER RACE OVERRUNNING

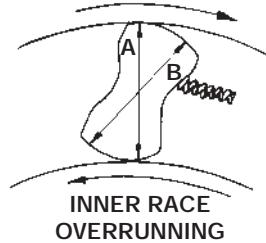

FIGURE 1  
(Overrunning)

OUTER RACE LOCKED

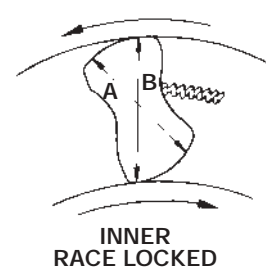

FIGURE 2  
(Driving)

The sprags are formed with the dimensions across one set of diametrically opposite corners "A", less than the radial gap between the inner and outer races, and the dimension across the other corners "B", greater than the radial gap. The spring load pushes the sprag towards engaging the longer side "B". In Fig. 1 when the outer race is rotated clockwise (or inner anti-clockwise) frictional drag between the races and the sprag work against the spring turning the sprag to its short length "A" and thereby allowing the races to run free. However, when the outer race is driven anti-clockwise (or inner clockwise), frictional drag between races and the sprag rotates the sprag to a locking position (Fig. 2), where the sprag length exceeds the radial gap, and torque is transmitted between the races. For correct operation it is essential that the two races are concentric and this is normally ensured by their own bearing assemblies. Sprag clutches provide compact high torque units suitable for overrunning, indexing and backstop applications. Generally designs favour the inner race overrunning as the sprags are retained with the outer race. Overrun speeds are limited by the frictional wear between sprag and inner races. Sprag clutches are not as tolerant of overloading as other freewheel designs, as permanent indentation of the races can occur or in extreme cases the sprags can be rolled over.

A number of different sprag designs are offered to suit designers specific needs:-

The Duo Cam "M" Series Clutches (p5-6) and PB Series (p7) provide the designer with a freewheel assembly complete with own bearings, and means of easy connection to other driven equipment. The "B" Series (p10) and BW assemblies (p9-10) are individual sprag assemblies for mounting on customers own races. The "B" Series Clutches are designed specifically for fitting inside gearboxes for backstop applications. The double cage design of the BW sprag enables it to be more tolerant of torsional loads.

Clutch type CKK (p8) combines a standard ball race with a sprag clutch giving relatively high torque capacity in an extremely small space and eliminating necessity of additional bearings. Clutch types CR/BW (p20) are designed specifically as a backstop for direct mounting on conveyor or elevator head shafts, and are complete with bearings and seals.

## Roller Ramp Clutches

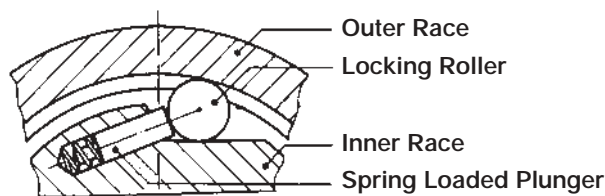

Roller ramp clutches consist of an outer race with cylindrical inside diameter, an inner race with wedge shaped friction faces (the "freewheel star") with locking rollers interspaced between the two. The locking rollers are individually spring loaded to provide constant contact between the rollers and the races.

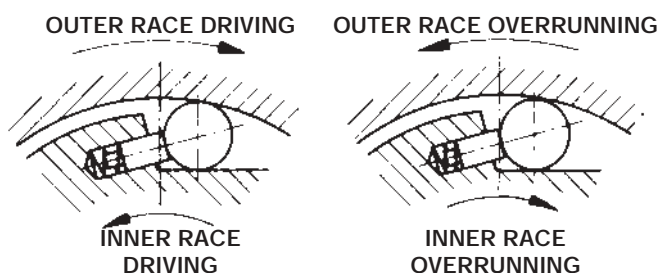

In Fig. 3 when the outer race is driven clockwise (or the inner counter-clockwise) the roller is forced up the inclined ramp by friction, locking the race and roller components to transmit load. The rollers move along the inclined plane to a point where the distance between the races is slightly smaller than the roller diameter and consequently wedging occurs.

In Fig. 4 when the outer race is driven counter-clockwise (or inner clockwise), the roller is forced down the inclined ramp permitting freewheeling of the clutch. Although the races move the roller into a free position, the spring-loaded plunger keeps the roller in very light contact with the races to ensure instantaneous engagement when the race rotation is reversed.

During the freewheeling mode the rollers are rotated by frictional drag of the outer race, thus circulating the oil film over plunger and inner race.

The change from overrunning to torque transmission is virtually instantaneous, as the rollers are always in contact regardless of the relative position of the inner and outer races; play or backlash is only a function of the oil film thickness between the rollers and the inner and outer races combined with the natural deformation of material under load.

The rotation of the rollers in freewheeling modes minimises wear in roller ramp clutches, and they are thus well suited to applications with long periods of overrunning. When used for overrunning the outer race should always be the freewheeling race, as if the inner race freewheels the rollers are subject to centrifugal loading which increases clutch wear.

Roller ramp clutches provide extremely accurate indexing as angular deflection between races under load conditions is minimal. If employed as an indexing clutch, the outer race should always perform the oscillating movement and the inner race the output function. If arranged in reverse order, the inertia of the rollers and springs would lead to inaccurate indexing, especially at high index rates. The installation of stronger compression springs, available upon request, will provide higher indexing precision.

A number of roller ramp clutch designs are offered to suit different applications, with basic units (p11-12); complete package units with their own integral bearings and a range of end flanges for attaching other driving equipment (p13-15); units complete with flexible couplings for shaft to shaft connection (p16); and units having others with integral torque arms (p15) for indexing and backstopping applications.

The roller ramp principle is also used for single revolution clutches (p18) by caging the rollers and controlling their function through the cage.

## Contact Free Element Sprag Clutches

These clutches are basically similar to conventional sprag clutches, however, in the overrunning mode the sprag elements are thrown out of contact with the stationary race by centrifugal force.

There are two basic types of clutch; internally disengaging clutches, where the sprag elements lift-off from the inner race (types CR and RS/BF); and externally disengaging clutches where the sprag elements break contact from the outer race and inner race (types RAZ, RIZ, RBI and RSBI).

These clutches are intended for applications involving long periods of high speed freewheeling, as no wear occurs in this mode. Internally-disengaging clutches consist basically of cylindrical inner and outer races, with a complement of specially designed sprag elements contained in a cage which is connected to the outer race.

### OUTER RACE OVERRUNNING

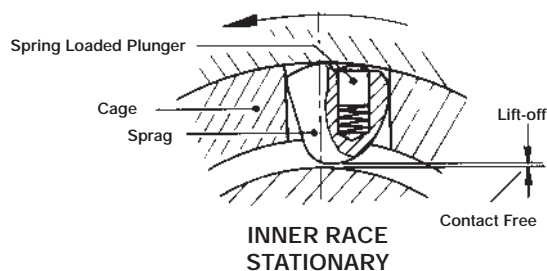

The sprags have a special shape so that when the outer race overruns centrifugal force acts on the sprags causing them to lift-off from the stationary inner race, resulting in a gap of 0.2 to 0.6mm depending on clutch size. As outer race speed decreases the sprag elements return to contact with the inner race. If the clutch attempts to go into reverse an immediate lock-up between inner and outer race occurs.

Type CB and RS/BF are designed so that the outer race connects to the drive shaft, and are solely used for backstop applications with high speed shaft, such as turbines and pumps.

Externally-disengaging clutches consist basically of a cylindrical outer race and an inner race fitted with coaxially arranged bolts, which support unique power transmitting sprag elements in a cage which is connected to either inner or outer race.

### OUTER RACE STATIONARY

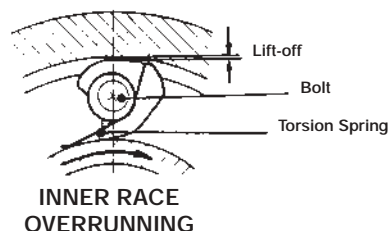

The unique shape of the sprags is such that when the connected race overruns centrifugal force acts on the sprags causing them to rotate until halted by contact on the inner race. A gap results between the inner and outer race and sprags of between 0.2 and 0.6mm depending on the freewheel size. As the overrunning race speed decreases the sprag elements return to frictional contact with the races.

If the clutch attempts to go into reverse and immediate lock-up between inner and outer races occurs.

Clutch type RBI and RSBI (p21) are designed as backstop clutches specifically for direct fitment on shaft extensions of electric motors and gearboxes. Types RAZ and RIZ (p21) can be used as backstops or overrunning clutches, and come complete with a range of flanges to enable easy assembly of driving gears, pulleys or sprockets.

Both RAZ and RIZ clutches are available with a rubber element flexible coupling for high speed overrunning applications requiring shaft to shaft connection.

**For assistance in selection and/or application of all types of freewheel clutches contact Clutch Engineering Sales on 0121 360 0155**

# "M" Series Sprag Clutches



**Fully sealed, bearing supported, high torque  
Sprag Clutch Assemblies with Metric and Imperial Bores.**

"M" series sprag clutches use precision cams made of high chrome alloy steel, hardened and honed for accurate shape. A unique finishing process ensures smooth cam surface providing uniform contact with both races for even load distribution and prolonged clutch life. High capacity bearings are used to accommodate radial and axial loads. The clutches are designed to mount directly on through shafts; the torque being transmitted by a matching key provided with each stock bore; the outer race has a precision ground diameter with tapped holes on each face to enable the fitting of gears, sprockets, pulleys, etc.

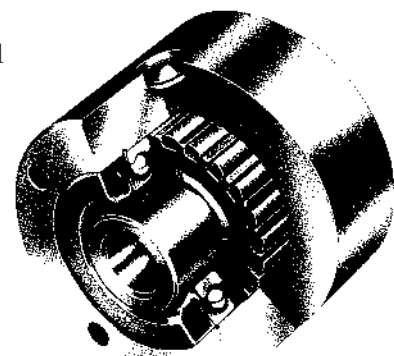

## Four types of clutch are offered:

**MG Series** - Standard clutch for general overrunning, backstop and index applications, standard oil lubricated with option of grease.

**MI Series** - Has special sprag assembly designed for high speed indexing. Always oil filled for optimum performance.

**MO Series** - Fitted with labyrinth seals for minimal drag on higher speed overrun and backstop applications. Always grease lubricated.

**MR Series** - Utilises a special sprag cage arrangement to allow high speed overrunning of the outer race. Oil lubricated clutch suitable as a higher torque alternative to Roller Ramp clutches.

**Vertical Shafts** - Clutches suitable for vertical shafting can be supplied - contact Cross & Morse sales office for technical advice.

**High Speed/Temperature Operation** - Clutches can be provided with a patented venting system for applications subject to high temperature variation or overrunning at high speed.

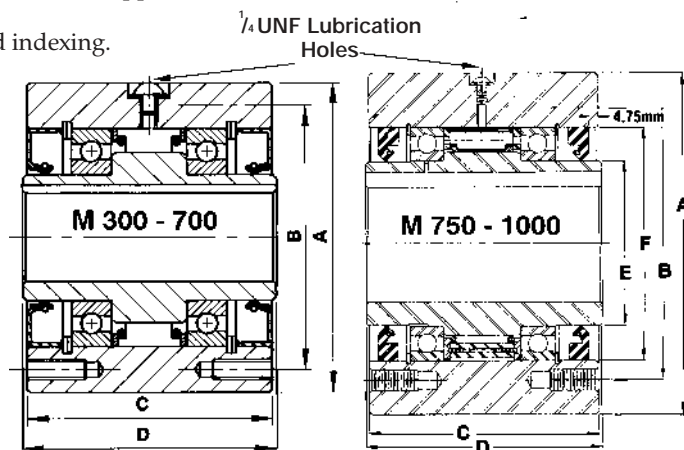

## Dimensions

Clutch Model Number	Torque Capacity Nm	Max Overrun Speed RPM		Nominal Overrun Drag Nm	Std. Bore & Key Sizes <sup>(1)</sup>				Dimensions in mm						No. <sup>(2)</sup> Tapped Holes	Thread Size U.N.F.	Usable Thread Depth mm	Approx Weight kg
		Inner <sup>(4)</sup>	Outer		Imperial		Metric		A	B	C	D	E	F				
					Bore ins <sup>(3)</sup>	Key	Bore ins <sup>(3)</sup>	Key										
MG 300 MI 300 MO 300 MR 300	373	2900 — 3600 800	800 — 800 2900	.23	5/8, 3/4	3/16x3/16	15mm 5x5	76.20 76.15	66.7	60.3	63.5	28.6	—	4	1/4-28	13	1.8	
MG 400 MI 400 MO 400 MR 400	542	2700 — 3600 800	800 — 800 2700	.28	3/4, 7/8	3/16x3/16	18mm 6x6 20mm 6x6	88.90 88.85	73.0	66.7	69.9	31.7	—	4	5/16-24	16	2.7	
MG 500 MI 500 MO 500 MR 500	1592	2400 — 3000 750	750 — 750 2400	.52	1, 1 1/4	1/4x1/4	25mm 8x7 30mm 8x7	107.95 107.90	92.1	85.7	88.9	44.4	—	4	5/16-24	16	5.0	
MG 600 MI 600 MO 600 MR 600	3050	1800 — 2400 700	700 — 700 2100	.85	1 1/2, 13/4 2	3/8x3/8 1/2x7/16	38mm 10x8 40mm 12x8 45mm 14x9 50mm 14x9	136.53 136.47	120.7	92.9	95.3	69.8	—	6	5/16-24	16	8.6	
MG 700 MI 700 MO 700 MR 700	6780	1200 — 2000 400	400 — 400 1750	1.76	2, 2 1/4 2 1/2, 2 3/4 3, 3 1/4	1/2x1/2 5/8x5/8 5/8x7/16	60mm 18x11 65mm 18x11 70mm 20x12 75mm 20x12 80mm 22x 9	180.98 180.92	158.8	123.8	127.0	101.6	—	8	3/8-24	19	19.5	
MG 750 MI 750	9500	1800 525 —	600 2600 —	3.4	27/16, 2 1/2, 2 3/4 2 15/16, 3 3 1/4 37/16	5/8x5/8 3/4x3/4 3/4x5/8 3/4x9/16	70mm 20x12 75mm 20x12 80mm 22x14 85mm 22x14	222.25 222.20	177.8	149.2	152.4	108.0	152.4	8	1/2-20	25	38	
MG 800 MI 800	17625	1300 475 —	475 2100 —	5.4	3, 3 1/4 37/16, 3 1/2, 3 3/4 3 15/16, 4 4 1/4 47/16	3/4x3/4 7/8x7/8 1x1 1x7/8 1x3/4	85mm 22x14 90mm 25x14 100mm 28x16 110mm 28x16	254.00 253.95	227.0	149.2	152.4	139.7	190.5	8	1/2-20	25	48	
MG 900 MI 900	24400	1200 400 —	400 1850 —	6.8	4, 4 1/4, 47/16 4 1/2, 43/4 4 15/16, 5 5 1/4, 57/16	1x1 1x1 1x7/8 1x3/4	100mm 28x16 120mm 32x18 130mm 32x18	304.80 304.72	247.6	158.7	161.9	165.1	222.2	10	5/8-18	32	72	
MG 1000 MI 1000	33900	1200 325 —	325 1600 —	8.2	5, 5 1/4, 57/16, 5 1/2 5 3/4, 5 15/16, 6 6 1/4, 67/16	1 1/4x1 1/4 1 1/4x1 1/16 1 1/4x1	130mm 32x18 150mm 36x20 160mm 40x22	381.00 380.92	298.5	171.4	177.8	196.8	266.7	12	5/8-18	32	115	

(1) Std. bores clutches normally available 24 hour despatch. Other bore sizes can be supplied to order. Clutches shipped with key.

(2) Mounting holes equally spaced except 700& 750 which have 6 equi-spaced plus two 30° from equi-spaced holes 180° apart.

(3) Bores to H7 tolerance except Imperial bores on MG 750-1000 which are to M7 tolerance.

(4) This also maximum drive speed MR series clutches.

**Note:** All oil filled clutches must be lubricated prior to operation.

# M Series Clutch Couplings and Stub Shaft Adaptors



## Standard Flexible Couplings

The "M" Series Clutch Couplings are for shaft to shaft connection on high speed overrunning applications, such as motor to large fan shaft.

Couplings C3 to C7 use Morse silent chain flexible couplings. Couplings C7.5 to C10 are Morse Gear Couplings. All couplings are fully sealed for grease lubrication.

It is preferred to overrun on clutch shaft, as this permits removal of driving machinery by disconnection at flexible coupling, without driven equipment being stopped. For clutch shaft overrunning select coupling with MG or MO clutch. If shaft diameters dictate that coupling will overrun select MR clutch.

Clutch Couplings accommodate up to 1/2 degree angular, and 0.25mm parallel misalignment plus end float as indicated in table.

- Specify direction of rotation of couplings •  
as viewed from clutch end
- Left hand is inner race driving      CCW •
- Right Hand is inner race driving      CW •

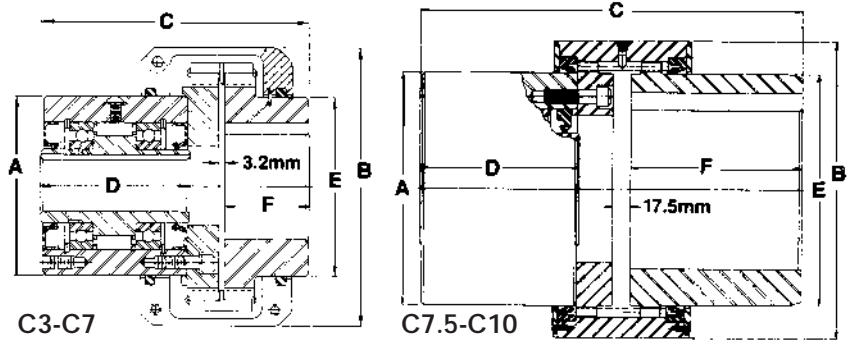
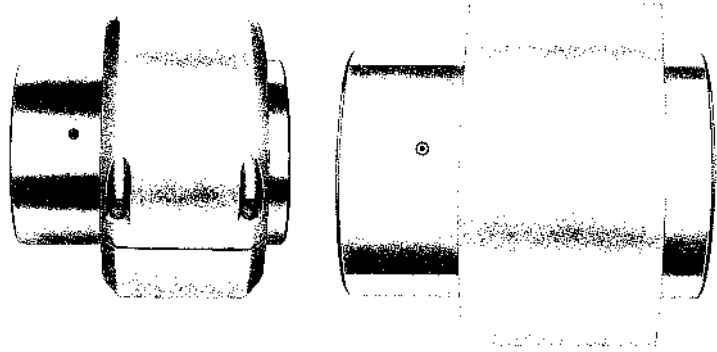

## Dimensions

Coupling No.	Clutch Model	Torque Capacity	Max Overrun Speed		Coupling Max Bore mm	Clutch* Max Bore mm	Dimensions in mm						Max End Float mm	Approx Weight kg
			Clutch rpm	Coupling rpm			A	B	C	D	E	F		
C3	MG 300	373	2900	800	51	19	76.2	124	125	63.5	76	46.0	+2.4 -0	3.6
	MO 300		3600	800										
	MR 300		800	2900										
C4	MG 400	542	2700	800	60	22	88.9	141	141	69.9	89	50.8	+4.8 -0	5.4
	MO 400		3600	800										
	MR 400		800	2700										
C5	MG 500	1590	2400	750	64	32	107.9	169	160	88.9	108	50.8	+4.8 -0	8.6
	MO 500		3000	750										
	MR 500		750	2400										
C6	MG 600	3050	1800	700	89	55	136.5	214	198	95.3	137	76.2	+6.3 -0	15.4
	MO 600		2400	700										
	MR 600		700	2100										
C7	MG 700	6780	1200	400	102	80	181.0	248	237	127.0	181	82.6	+6.3 -0	23.6
	MO 700		2000	400										
	MR 700		400	1750										
C7.5	MG 750	9500	1800	600	152	85	222.2	286	365	152.4	222	163.5	+6.3 -15.9	68
	MR 750		525	2600										
C8	MG 800	17625	1300	475	165	110	254.0	318	365	152.4	254	163.5	+6.3 -15.9	77
	MR 800		475	2100										
C9	MG 900	24400	1200	400	203	140	304.8	378	379	161.9	305	168.3	+6.3 -15.9	113
	MR 900		400	1850										
C10	MG 1000	33900	1200	325	203	160	381.0	448	410	177.8	305	184.1	+6.3 -15.9	136
	MR 1000		325	1600										

\*Refer to clutch tables for standard bore sizes. Coupling halves can be supplied to any recognised std bore up to max. indicated.

## Stub Shaft Adaptor

The Morse flanged sub-shaft adaptor is used when it is impractical to mount a sprocket, gear, sheave or other mechanical device directly to the mounting holes of the Morse cam clutch Models 300-1000.

The stub shaft diameter is designed to take full advantage of the clutch-torque capacity, but may be turned to smaller diameter to special order, including metric shaft sizes.

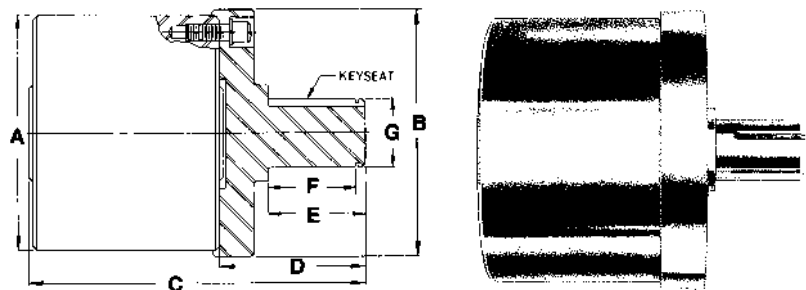

Adaptor No.	Clutch Model	Dimensions mm						Shaft Dia. G ins	Keyway ins	Weight kg
		A	B	C	D	E	F			
A3	300	76.2	82.6	122.9	61.1	38.1	33.4	.751/ .750	1/4x1/8	0.62
A4	400	88.9	95.3	129.4	61.1	38.1	33.4	.751/ .750	1/4x1/8	0.72
A5	500	107.9	114.3	157.2	69.9	44.5	39.0	1.251/1.250	5/16x5/32	1.42
A6	600	136.5	142.9	171.5	77.8	50.8	45.2	1.751/1.750	3/8x3/16	2.60
A7	700	181.0	187.3	214.3	88.9	63.5	56.6	2.752/2.750	5/8x5/16	5.60
A7.5	750	222.2	211.1	266.7	115.9	76.2	68.6	3.252/3.250	3/4x3/8	10.60
A8	800	254.0	260.3	282.6	131.8	95.2	87.5	4.252/4.250	1x1/2	18.00
A9	900	304.8	292.1	311.1	150.8	114.3	106.1	5.252/5.250	1 1/4x5/8	27.90
A10	1000	381.0	355.6	352.4	177.8	139.7	128.2	6.252/6.250	1 1/4x5/8	46.00

# Types PB & HT Sprag Clutches



PB Sprag Clutches feature precision formed sprags for maximum torque capacities combined with long life. The clutches have an outer race designed to simply attach sprockets, gears or pulleys with a plain bearing to support high radial loads. They are pre-lubricated with grease suitable for temp range -10 to +50°C. Oil lubricated clutches can also be supplied to order (except PB3A). These clutches are suitable for general purpose overrunning and indexing applications.

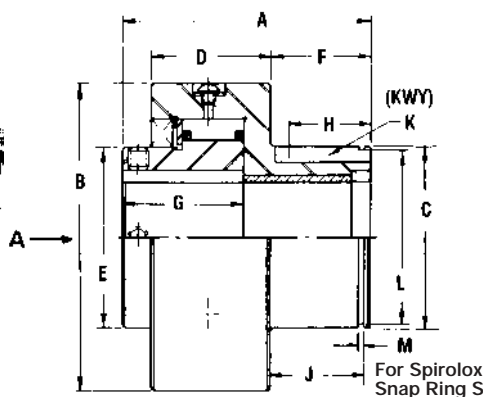
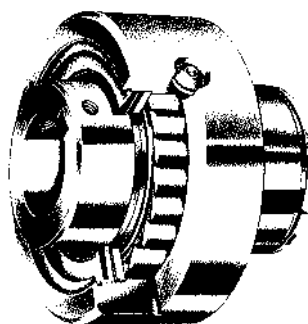

## Dimensions

Model No. <sup>(1)</sup>	Nominal Torque Nm <sup>(2)</sup>	Max Overrun rpm		Bore Sizes ins <sup>(3)</sup>		Dimensions mm												Snap Ring S Ref	Weight kg
		Inner	Outer	Bore	Keyway	A	B	C	D	E	F	G	H	J	K	L	M		
PB-3A	54	1800	900	.375 .500	1/8x1/16 Roll Pin	47.63	50.80	22.23 22.20	19.84	21.43	20.64	23.81	12.70	18.16 18.29	1/8x1/16	21.21 21.36	0.92 1.42	RS 87	.34
PB-5A	149	1800	900	.500 .625	1/8x1/16 3/16x3/32	69.85	50.80	31.75 31.73	31.75	25.40	25.40	39.69	17.46	22.86 22.99	3/16x3/32	30.63 30.43	1.22 1.73	RS125	.80
PB-6A	406	1800	800	.750	3/16x3/32	82.25	73.03	34.93 34.90	39.69	34.93	33.34	41.28	25.40	30.86 30.99	3/16x3/32	33.71 33.50	1.22 1.73	RS137	1.60
PB-8A	610	1600	650	.875 1.000	3/16x3/32 1/4x1/8	90.48	82.55	44.45 44.43	42.86	41.28	36.51	44.45	26.99	33.40 33.53	1/4x1/8	43.08 42.82	1.42 1.93	RS175	1.70
PB-10A	915	1200	400	1.125 1.250	1/4x1/8	88.90	95.25	57.15 57.13	43.66	50.81	36.51	42.86	26.99	34.04 34.16	5/16x5/32	55.42 55.12	1.42 1.93	RS225	2.73
PB-12A	1830	1200	300	1.375 1.500	5/16x5/32 3/8x3/16	98.43	112.71	63.50 63.48	47.63	60.33	36.51	52.39	28.58	33.30 33.55	3/8x3/16	60.73 60.43	3.05 3.30	RS250	3.86
PB-14A	2169	950	300	1.625 1.750	3/8x3/16	111.13	139.70	73.03 73.00	53.98	76.20	44.45	50.80	34.93	41.28 41.40	7/16x7/32	70.79 70.49	1.42 1.93	RS285	6.69
PB-16A	2440	950	300	1.875 2.000	1/2x1/4	113.13	139.70	82.55 82.53	53.98	82.55	44.45	53.98	36.51	41.91 42.04	1/2x1/4	80.16 79.86	1.73 2.24	RS325	6.80

(1) When ordering specify bore size and direction.

Viewed from direction "A" clutch suffix "L" - inner race drives CCW  
"R" - inner race drives CW

(2) Maximum torque for short periods 1.5x Nominal torque.

(3) Metric Bore clutches are available to order. Sizes PB5-PB16.

Bold print indicates preferred imperial sizes.

HT Sprag Clutches are designed for end of shaft applications, being retained on the shaft by a deep groove ball bearing with snap ring in outer race locating in recess dia. D.

The outer race of the clutch is tapped for attaching sprocket, gear or ratchet arm. Intended primarily for indexing applications, the clutches can also be used for backstop and overrun applications providing the inner race is overrunning.

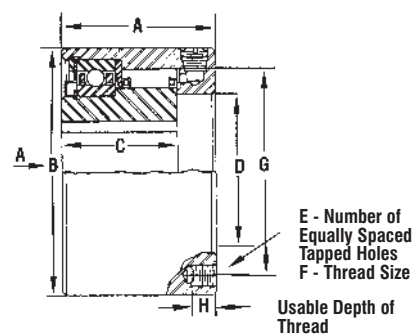
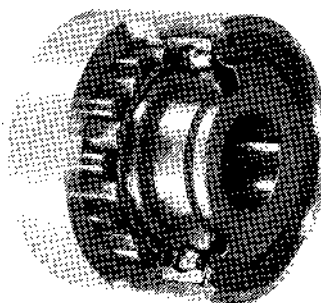

Model No. <sup>(1)</sup>	Nom Torque Nm	Drag Torque Nm	Max Shaft rpm	Std Bores (ins)		Dimensions mm						Tapped Holes		Snap Ring Brg*		App Wt kg
				Bore	Keyway	A	B	C	D	G	H	No.	U.N.F.	Ref	Bore	
HT-10	57	0.3	1600	0.625	3/16x3/32	54.0	60.3	39.7	30.00/30.01	47.62	9.5	4	1/4-28	6200N	10	1.2
HT-20	209	0.4	1200	1.125 1.250 1.312	1/4x1/8 1/4x1/8 5/16x5/32	57.9	90.5	42.9	51.99/52.01	69.85	9.5	4	5/16-24	6304N 6205N	20 25	2.3
HT-30	597	0.5	900	1.500 1.750 1.937 2.000	3/8x3/16 3/8x3/16 1/2x1/4 1/2x1/4	69.9	114.3	52.4	71.99/72.01	95.25	11.9	6	3/8-24	6306N 6207N	30 35	5.0

(1) When ordering specify bore size and direction.

Viewed from direction "A" clutch suffix "L" - inner race drives CCW  
"R" - inner race drives CW

\*Before installation a snap-ring ball bearing must be inserted in the counterbored end complete with a gasket or seal to retain the lubricant. Snap-ring ball bearing not supplied with clutch.

Always apply pressure on the inner race when installing. It is important that the clutch fits snug on the shaft and has proper fitting keys.

HT series clutches are lightly lubricated prior to despatch as an anti-corrosive measure, and must be fully lubricated after the snap-ring ball bearing has been incorporated. Use Type A automatic transmission fluid. Fill until oil runs out between hub and end cap.

# Types CKK & CSK Sprag Clutches



Clutch types CKK and CSK combine individually sprung sprags with a deep groove ball bearing to provide a compact, low cost high torque freewheel. Used for backstop and overrun applications, these clutches provide the ideal, low cost, solution where space is restricted.

Type CKK clutches are manufactured to the same specification as 62 Series ball bearings (except CKK 8) enabling direct interchange.

Type CKKN clutches have inner race keyseated to DIN 6885 sht. 3 (except CKKN 40) to enable torque transmission by key. Clutches can also be provided to order with keyseat on outer race (Type CKKNN).

Type CKK-RS and CKKN-RS are fitted with metal shields and 'O' rings to retain lubricant and exclude dust, for applications where relubrication is impractical or units running at higher temperatures.

Type CSK-RS has extended width races to enable fitting full rubber sealing discs, making them ideal for dusty applications. These units can also be supplied to order with inner race keyseated (Type CSKN-RS).

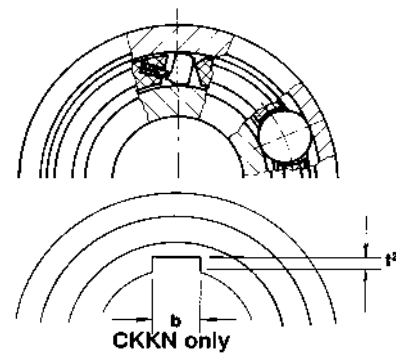
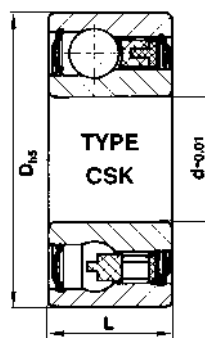
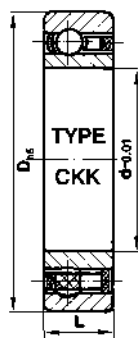
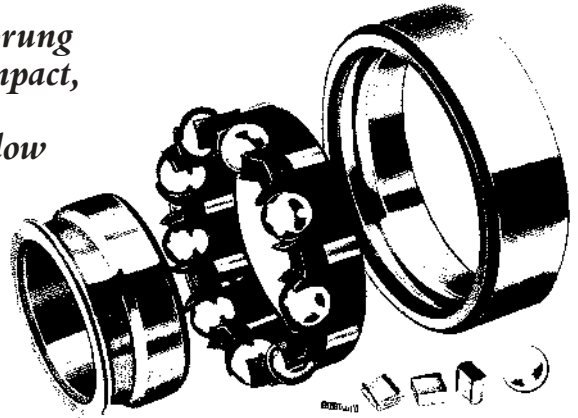

## Dimensions

Clutch Size	Torque* Capacity Nm	Drag Torque N cms	Max. Speed Overrun rpm	Dimensions mm					Equivalent Brg. Ref.	Bearing Capacity		Approx. Weight gm
				d	D	L	b	t		Dynamic kN	Static kN	
CKK 8**	2.0	0.5	15,000	8	22	9	-	-	-	3.28	0.86	15
CKK 12	7.4	0.7	10,000	12	32	10	-	-	6201	6.10	2.77	40
CKK 15	13.5	0.9	8,400	15	35	11	-	-	6202	7.40	3.42	60
CKK 17	24.5	1.1	7,350	17	40	12	-	-	6203	7.90	3.80	70
CKK 20	40.0	1.3	6,000	20	47	14	-	-	6204	9.40	4.46	110
CKK 25	68.0	2.0	5,200	25	52	15	-	-	6205	10.70	5.46	140
CKK 30	110.0	4.4	4,200	30	62	16	-	-	6206	11.70	6.45	210
CKK 35	140.0	5.8	3,600	35	72	17	-	-	6207	12.60	7.28	300
CKK 40	260.0	7.0	3,000	40	80	22	-	-	-	15.54	12.25	500
CKKN 15	13.5	0.9	8,400	15	35	11	5	1.2	6202	7.40	3.42	60
CKKN 17	24.5	1.1	7,350	17	40	12	5	1.2	6203	7.90	3.80	70
CKKN 20	40.0	1.3	6,000	20	47	14	6	1.6	6204	9.40	4.46	110
CKKN 25	68.0	2.0	5,200	25	52	15	8	2.0	6205	10.70	5.46	140
CKKN 30	110.0	4.4	4,200	30	62	16	8	2.0	6206	11.70	6.45	210
CKKN 35	140.0	5.8	3,600	35	72	17	10	2.4	6207	12.60	7.28	300
CKKN 40	260.0	7.0	3,000	40	80	22	12	3.3	-	15.54	12.25	500
CKK 17RS†	27.0	4.5	3,700	17	40	12	-	-	6203	6.55	3.17	70
CKK 20RS	37.0	4.8	3,200	20	47	14	-	-	6204	7.32	3.87	110
CKK 25RS	63.0	5.6	2,800	25	52	15	-	-	6205	7.98	4.57	140
CKK 30RS	88.0	6.2	2,400	30	62	16	-	-	6206	8.45	5.29	210
CKK 35RS	136.0	8.5	1,900	35	72	17	-	-	6207	9.30	6.70	300
CKKN 17RS†	27.0	4.5	3,700	17	40	12	5	1.2	6203	6.55	3.17	70
CKKN 20RS	37.0	4.8	3,200	20	47	14	6	1.6	6204	7.32	3.87	110
CKKN 25RS	63.0	5.6	2,800	25	52	15	8	2.0	6205	7.98	4.57	140
CKKN 30RS	88.0	6.2	2,400	30	62	16	8	2.0	6206	8.45	5.29	210
CKKN 35RS	136.0	8.5	1,900	35	72	17	10	3.3	6207	9.30	6.70	300
CSK 12RS	7.4	3.0	10,000	12	32	14	-	-	-	6.10	2.77	50
CSK 15RS	13.5	4.0	8,400	15	35	16	-	-	-	7.40	3.42	70
CSK 17RS	24.5	5.6	7,350	17	40	17	-	-	-	7.90	3.80	90
CSK 20RS	40.0	6.0	6,000	20	47	19	-	-	-	9.40	4.46	145
CSK 25RS	68.0	6.0	5,200	25	52	20	-	-	-	10.70	5.46	175
CSK 30RS	110.0	7.5	4,200	30	62	21	-	-	-	11.70	6.45	270
CSK 35RS	140.0	8.2	3,600	35	72	22	-	-	-	12.60	7.28	400

\*Nominal Torque - Max. torque for short periods = 2.5 x nom. Torque (Max. 250,000 cycles).

\*\*CKK 8 has metal seal, type 'Z', on bearing side only when viewing seal the inner clutch overruns clockwise direction.

†CKK17RS has seal on clutch side only. When viewing seal the inner race overruns counterclockwise direction.

Permissible operating temperature is between -40°C to 130°C with max. 150°C possible for short periods. Above 50°C sealed units, or additional sealing must be used to retain lubrication. Clutches are made with bearing clearance C5 to permit reduced clearance when installed. Torque is transmitted by press fit with recommended housing tolerance N6, and shaft tolerance n6, except keyseated clutches where shaft tolerance k6 recommended.

# Sprag Clutches

The double cage sprag elements are complete units capable of high torque transmission within confined spaces. Their unit construction enables easy assembly into cylindrical inner and outer races to provide a complete clutch suitable for most overrunning, backstopping and indexing applications.

The sprags are individually energised by a brass ribbon spring, but their relative movement to one another is controlled by the double cage design to ensure load sharing and prevent de-phasing of individual sprags.

Standard sprags are manufactured from 52100 bearing steels. Two basic designs of sprag are available, disengaging types (Diseng.) where the sprag lifts-off from the inner race when the outer is rotated at high speeds, and engaging types (Eng.) where the contact forces between sprag and inner race increase as the outer race is rotated. The sprag element is designed to rotate with the outer housing, this being essential for correct operation of the unit. In applications with rapid speed changes additional clamping of the element to the housing is essential and this is achieved by clips/T bars fixed to the outer cage. To reduce wear of sprags during overrunning drag strips may be fixed to the inner cage to rotate this relative to the outer and so reduce sprag contact during overrun.

The table below shows dimensions and construction of standard sprag elements in heavy print are preferred sizes, normally available from stock, which should always be used for new designs unless large production volumes are envisaged.

Sprag elements are best applied where high torque transmission is required, but space is limited, and where direct installation into machine parts is required.

The clutches double cage design makes them particularly suitable where torsional vibrations are present. Ability to control the operating characteristics has made them suitable for a wide range of applications including turbine starters, marine drives, gearbox backstops, winches, printing machines and machine tools.

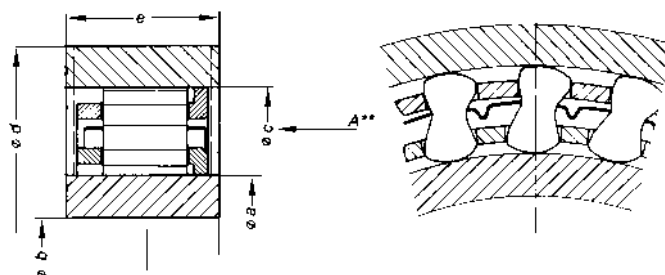
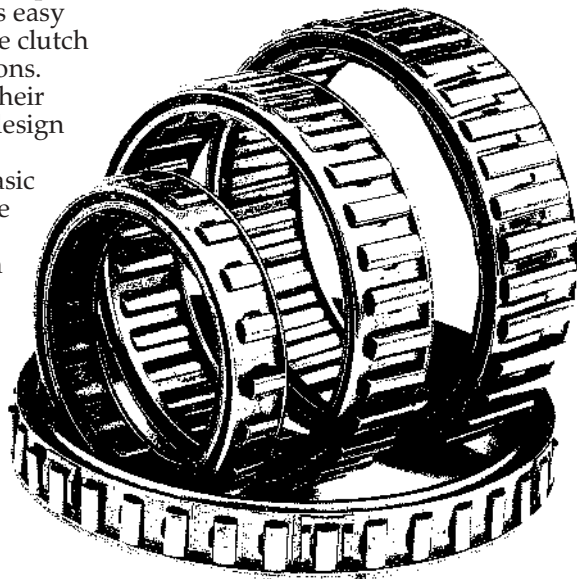

## Dimensions

Clutch Part No.	Dimensions mm					Sprags		No. Drag Strips	No NClips or T Bar	Direction Operation **	Nominal Torque <sup>(2)</sup>	Approx Weight
	Std Sprag	a* + .008 - .005	c + .013 - .013	e min	b max	d min	No.					
133590	22.225	38.887	10.0	17	50	12	Diseng.			CW	74	30
13143	27.767	44.425	13.5	21	58	14	Eng.			CW	139	55
133034	30.342	47.000	13.5	23	62	14	Diseng.			CW	124	60
1310028	31.750	48.410	13.5	24	63	16	Diseng.		3	CW	159	66
133392	38.092	54.750	16.0	30	71	18	Diseng.			CCW	324	85
1310145	41.275	57.937	13.5	32	75	14	Diseng.		3	CW	210	90
132909	44.450	61.112	16.0	34	79	20	Diseng.	2	3	CW	424	100
133339	49.721	66.383	13.5	38	85	22	Diseng.	2	4	CW	366	100
1310003	49.721	66.383	13.5	38	85	22	Diseng.		4	CW	366	100
1310172	54.765	71.427	16.0	42	92	24	Eng.			CW	640	120
1310226	54.765	71.427	16.0	42	92	24	Diseng.	2	4	CW	610	130
136709	54.765	71.427	21.0	42	92	24	Eng.	3	10	CW	907	180
1310147	54.765	71.427	25.4	42	92	24	Diseng.	3	8	CW	1160	200
13239	57.760	74.427	16.0	45	95	26	Eng.			CW	710	110
136324	57.760	74.427	19.0	45	95	26	Eng.			***	710	130
1310299	59.537	76.200	28.9	46	98	26	Eng.		4	***	1418	240
136334	63.340	80.000	21.0	50	104	26	Diseng.			CW	806	175
1310080	72.217	88.882	13.5	56	115	30	Diseng.			CW	793	140
13168	72.217	88.882	21.0	56	115	30	Eng.			CCW	1520	185
134012	72.217	88.882	21.0	56	115	30	Eng.	4	10	CCW	1489	215
133687	79.698	96.363	13.5	62	124	24	Diseng.	3	4	CW	680	155
137322	79.698	96.363	25.4	62	124	34	Diseng.	5	12	CW	2396	280
138334	83.340	100.000	25.4	65	130	34	Diseng.			CW	2055	270
138316	83.597	102.596	25.4	65	132	34	Diseng.	5	12	CW	3032	275
134008	85.776	104.776	25.4	66	135	34	Eng.	5	17	CW	3073	280
136715	87.290	103.960	16.0	67	135	34	Diseng.			CW	1470	165
13261	103.231	119.983	16.0	80	154	40	Diseng.	6	10	CCW(1)	1900	205
13236	117.391	136.391	16.0	91	176	30	Diseng.	5	6	CCW	1970	240
1312334	123.340	140.000	25.4	96	181	50	Diseng.			CW	4800	400
133403	123.881	142.880	25.4	96	184	44	Eng.			CW	5740	460
133403B	123.881	142.880	25.4	96	184	44	Eng.		11	CW	5740	470

\*For shaft dia. 75mm plus tolerance extended to ±0.013mm.

\*\*Direction of rotation of outer race freewheeling viewed from 'A'.

\*\*\*These clutches are fitted with end bearings.

(1) Note the centering flanges on type 13261 face each other.

(2) Nominal torque can be exceeded to maximum 1.7x for short periods.

# Shaft Mount Backstop Clutches and Standard Races for Sprag Elements



Shaft Mounted Sprag Clutch Assemblies for Backstop Applications

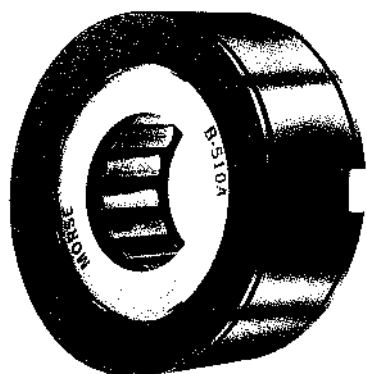

Types B200 & 500

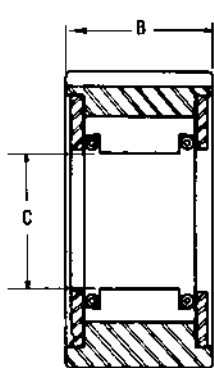

B200 Series Plain Outer Race

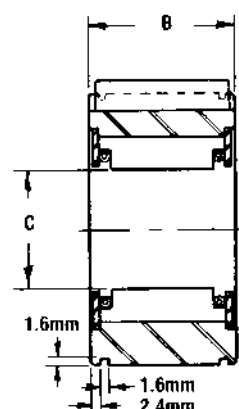
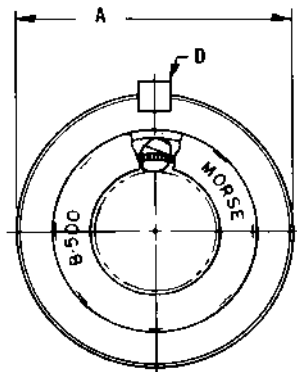

B500 Series with Circlip Grooves

## Dimensions

Clutch Size	Nominal Torque <sup>(1)</sup> Nm	Max Shaft Overrun rpm	Dimensions				Approx Weight kg	Standard Bearing with same O.D.
			A mm	B mm	C <sup>(2)</sup> mm	D ins		
B 203A	53	2500	39.99/39.95	25.4	16.51/16.49	1/8x1/16	.23	6203
B 204A	68	2500	46.99/46.95	25.4	18.80/18.77	3/16x3/32	.34	6204
B 205A	108	2500	51.98/51.94	25.4	23.62/23.60	3/16x3/32	.34	6205
B 206A	237	2000	61.98/61.95	28.6	32.77/32.74	1/4x1/8	.45	6206
B 207A	373	2000	71.99/71.95	28.6	42.09/42.06	1/4x1/8	.57	6207
B 208A	550	1800	79.99/79.95	31.8	46.76/46.74	3/8x3/16	.79	6208
B210A	780	1800	89.99/89.95	31.8	56.11/56.08	3/8x3/16	.91	6210
B 501A	82	2500	39.99/39.97	25.4	16.51/16.50	1/8x1/16	.23	6203
B 502	82	2500	46.96/46.94	22.2	18.75/18.74	1/4x1/8	.34	6204
B 506	217	2000	61.96/61.94	25.4	28.79/28.77	1/4x1/8	.34	6206
B 507A	217	2000	61.96/61.94	28.6	24.65/24.63	1/4x1/8	.45	6206
B 509A	339	2000	71.96/71.94	31.8	28.79/28.77	1/4x1/8	.68	6207
B 510A	339	2000	79.97/79.94	34.9	32.93/32.91	3/8x3/16	.79	6208
B 511A	712	2000	79.97/79.94	41.3	34.99/34.97	3/8x3/16	.91	6208
B 512A	882	2000	89.97/89.94	41.3	39.14/39.12	3/8x3/16	.91	6210
B 513	1695	1800	120.65/120.62	44.4	51.96/51.94	1/2x1/4	1.13	-

(1) Max torque capacity for short periods 1.7x torque.

(2) Required shaft diameter for correct operation. Shaft should be made from high tensile carburising steels hardened to 58-62 Rc with minimum case 1.2mm after grinding. Grind to 0.4 um surface finish, with parallelism within 0.2%.

## Inner and Outer Races for Standard Sprag Element

A range of standard inner and outer race for the most popular sizes of sprags, manufactured from carburised hardened steel with all faces finish ground. Maximum torque capacity of these races is controlled by the keys, and not sprag clutch rating. Housings for races should be manufactured to H7 tolerance

and shafts to j6. Race type B transmits torque through heavy press fit in housing. These races eliminate the need to harden shafts and housings, and enable servicing of machines by replacement after normal service wear.

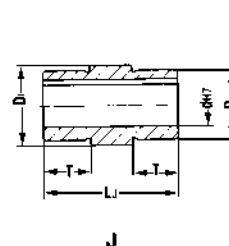
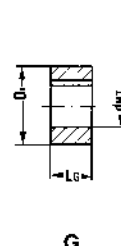
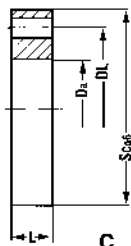
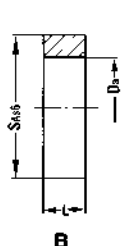
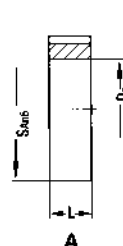
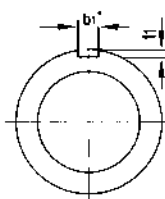

Type	Std Bore Sizes dH7*	Dimensions mm													For + Clutch Nos.
		Da ±0.013	SA	Sc	L	b1	t1	No. Holes x dia.	DL ±0.1	Di +.008/-0.005	D j6	LG	LJ	T	
230A/230B/230C 230G/230J	10, 15, 20	54.750	72	95	16	6	3.5	8x7.0	78	39.092	35	16	50	17	133392
167A/167B/167C 167G/167J	20, 30, 35	71.427	90	110	16	10	5.0	8x9.0	95	54.765	50	16	54	19	1310172 1310226
168A/168B/168C 168G/168J	40, 45, 50	88.882	110	140	21	14	5.5	8x11.0	120	72.217	65	21	63	62	1310080 13168 134012

\* Keyways to DIN 6885 sht. 1. + Races for other Sprag Clutches can be supplied to order.

# Types CNAS and CNFS Roller Ramp Clutches



Types CNAS and CNFS freewheels are light duty roller ramp clutches manufactured to standard bearing dimensions; CNAS type as 62 series ball bearings and CNFS type as NU 23 roller bearings. The clutches are mainly used for precision indexing and overrunning applications. Torque transmission is via a key on the shaft, and for type CNAS a press fit of outer into housing, and type CNFS via two keys in the end face of the outer race.

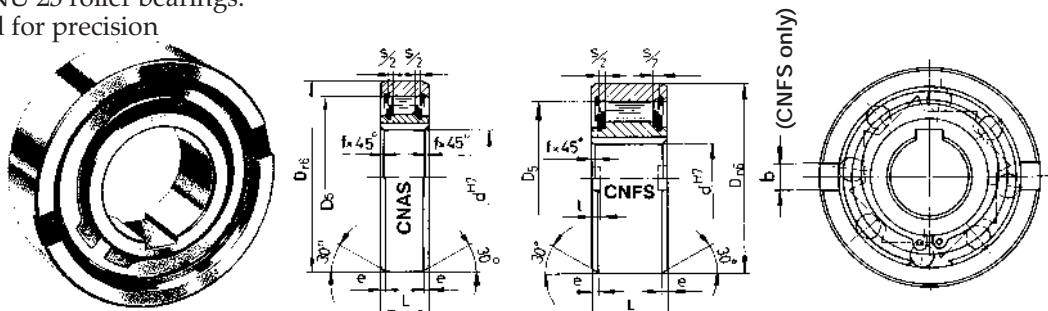

## Dimensions Type CNAS

Clutch Size	Bore mm	Nominal Torque <sup>(1)</sup>	Max Overrun <sup>(2)</sup>		Dimensions mm						Approx Weight	Overrun Drag Torque
			Inner Race	Outer Race	D <sub>6</sub>	D <sub>5</sub>	L	s*	e	f		
CNAS 6	6	1.7	5000	7500	19	15.8	6	0.8	0.6	0.3	0.01	0.18
CNAS 8	8	3.0	4300	6500	24	20	8	1.3	0.6	0.3	0.02	0.24
CNAS 10	10	5.4	3500	5200	30	25.9	9	1.3	0.6	0.3	0.03	0.36
CNAS 12	12	10	3200	4800	32	28	10	1.3	0.6	0.3	0.04	0.48
CNAS 15	15	11	2800	4300	35	31	11	1.4	0.6	0.3	0.05	0.70
CNAS 20	20	32	2200	3300	47	40	14	2.4	0.8	0.8	0.12	1.4
CNAS 25	25	45	1900	2900	52	45.9	15	2.4	0.8	0.8	0.14	2.4
CNAS 30	30	72	1600	2400	62	55	16	2.4	0.8	1	0.22	7.8
CNAS 35	35	114	1300	2000	72	64	17	2.5	0.8	1	0.31	9.0
CNAS 40	40	148	1200	1800	80	72	18	2.5	0.8	1	0.39	10
CNAS 45	45	174	1000	1600	85	77	19	2.5	1.2	1	0.44	11
CNAS 50	50	184	950	1500	90	82	20	2.5	1.2	1	0.49	13
CNAS 55	55	246	800	1300	100	90	21	2.5	1.2	1	0.66	14
CNAS 60	60	406	700	1100	110	100	22	2.5	1.2	1.5	0.81	26
CNAS 80	80	850	600	900	140	128	26	2.5	1.2	1.5	1.41	58

## Dimensions Type CNFS

Clutch Size	Bore	Nominal Torque <sup>(1)</sup>	Max <sup>(2)</sup> Overrun		Dimension mm								Approx Weight	Overrun Drag Torque
			Inner Race	Outer Race	D <sub>6</sub>	L	D <sub>5</sub>	b	t	s*	e	f		
CNFS 8	8	9	3300	5000	35	13	28	4	1.4	2.4	0.6	0.3	0.07	1.6
CNFS 12	12	9	3300	5000	35	13	28	4	1.4	2.4	0.6	0.3	0.06	1.6
CNFS 15	15	24	2400	3600	42	18	37	5	1.8	2.4	0.8	0.3	0.11	1.9
CNFS 17	17	39	2300	3400	47	19	40	5	2.3	2.4	1.2	0.8	0.15	1.9
CNFS 20	20	62	2100	3100	52	21	42	6	2.3	2.4	1.2	0.8	0.19	1.9
CNFS 25	25	100	1700	2600	62	24	51	8	2.8	2.4	1.2	0.8	0.38	5.6
CNFS 30	30	204	1400	2200	72	27	60	10	2.5	2.4	1.8	1	0.54	14
CNFS 35	35	306	1200	1900	80	31	70	12	3.5	2.4	1.8	1	0.74	16
CNFS 40	40	430	1100	1700	90	33	78	12	4.1	2.5	1.8	1	0.92	38
CNFS 45	45	624	1000	1600	100	36	85	14	4.6	2.5	1.8	1	1.31	43
CNFS 50	50	810	850	1350	110	40	92	14	5.6	2.5	1.8	1	1.74	55
CNFS 60	60	1460	750	1050	130	46	110	18	5.5	3.6	2.6	1.5	2.77	110
CNFS 70	70	1840	600	950	150	51	125	20	6.9	3.6	2.6	1.5	4.16	140
CNFS 80	80	2620	550	850	170	58	140	20	7.5	3.6	2.6	1.5	6.09	180
CNFS 90	90	4260	500	750	190	64	160	20	8.0	3.6	2.6	2	8.20	230
CNFS 100	100	5800	450	680	215	73	175	24	8.5	3.6	2.6	2	12.60	380
CNFS 120	120	10800	370	550	260	86	215	28	10	3.6	2.6	2.5	22	650
CNFS 150	150	21300	300	460	320	108	260	32	12	3.6	3.6	2.5	42	1000
CNFS 200	200	35600	230	350	420	138	350	45	16	7.6	3.6	3	93	2000

(1) Nominal torque can be exceeded up to 2.5x for brief periods only.

(2) Speeds for oil lubrication system.

For Grease lubrication x0.50.

\* Axial clearance optional see below.

Keyways:- CNAS 6 without keyway

CNAS 8, 10 & 12, CNFS 8, CNFS 12, CNFS 200 to DIN 6885/1.

Other sizes to DIN 6885/3.

## Installation

Our design makes precise axial adjustment of outer and inner races unnecessary. The two races may be shifted to either side by dimension "S/2", without generating axial tension. Modified freewheels in which the axial clearance "S" is reduced to a minimum are available on request. These freewheels are identified by the index "S", e.g. CNFS 20-S.

Torque transmission from shaft to inner race is via a key, with recommended shaft tolerance h6 or j6 (except CNAS 6 which requires n6).

On type CNAS torque transmission from outer is interference fit obtained with housing bore tolerance H6 or J7. On type CNFS torque transmission is normally via two keys fitted in the end face of the outer race, when housing bore tolerance of H7 or F7 is advised; but if keys are not used housing bore must be to K6 tolerance to transmit torque.

### Note:

Types CNAS & CNFS freewheels have no integral bearings. Inner and outer races must be precisely aligned by external bearings.

# Types AA, AE, ANF and ANR Roller Ramp Clutches



These freewheels are high torque roller ramp clutches for applications within an encased lubrication system. Torque is transmitted by keyway in bore and 2 keyseats on end faces of outer race (except AA series). Type AA has drilled outer race to bolt to gears, or to machine housing if used as backstop when cover F4 from AGF series can be used to provide fully sealed unit. Types AA and AEF incorporate axial clearance "S" to avoid need for precise axial positioning of inner and outer races. This can also accommodate shaft temperature expansion. Type ANR incorporates its own bearings to centre inner and outer races. Size ANR 8-20 have steel on steel plain bearing, whilst larger units use two series 160 ball-bearings.

Type AA Drilled Outer Race

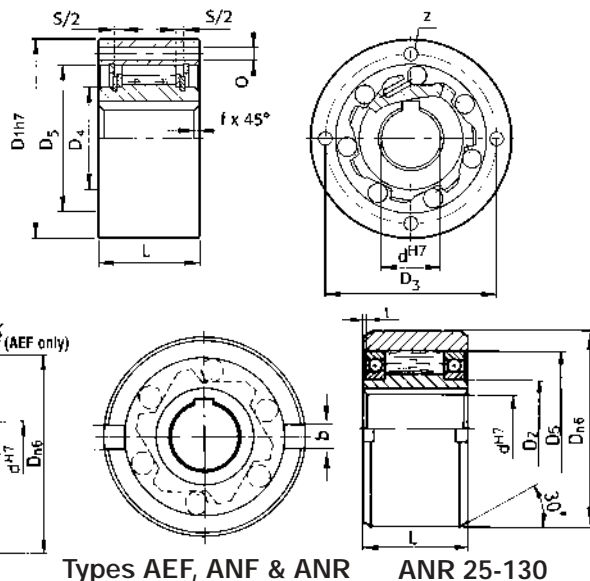

Types AEF, ANF & ANR ANR 25-130

## Dimensions ANF & ANR Series

Clutch Size		Nom <sup>(1)</sup> Torque Nm	Max Overrun rpm		Dimensions mm										Bearing Size	App. Wt. kg	
ANF	ANR		Inner	Outer	dH7	Dn6	D2	D4	D5	L	1	BH11	t	ANF		ANR	
ANF 8		16	4000	6000	8	37		20	30	20	-	6	3.0	-	0.1	-	
ANF 12		16	4000	6000	12	37		20	30	20	-	6	3.0	-	0.1	-	
ANF 15		62	3600	5400	15	47		26	37	30	-	7	3.5	-	0.3	-	
ANF 20		150	2700	4600	20	62		37	52	36	-	8	3.5	-	0.6	-	
ANF 25	ANR 25	200	2100	3600	25	80	40	49	68	40	0.2	9	4.0	16008	1.1	1.2	
ANF 30	ANR 30	400	1700	3200	30	90	45	52.5	75	48	0.2	12	5.0	16009	1.6	1.8	
ANF 35	ANR 35	530	1550	3000	35	100	50	58	80	53	1.2	13	6.0	16010	2.3	2.4	
ANF 40	ANR 40	880	1150	2600	40	110	55	62	90	63	2.2	15	7.0	16011	3.1	3.3	
ANF 45	ANR 45	1200	1000	2400	45	120	60	69	95	63	2.2	16	7.0	16012	3.7	4.0	
ANF 50	ANR 50	1900	800	2150	50	130	70	82	110	80	2.7	17	8.5	16014	5.4	5.7	
ANF 55	ANR 55	2000	750	2000	55	140	75	83	115	80	4.2	18	9.0	16015	6.1	6.5	
ANF 60	ANR 60	3400	650	1900	60	150	80	93.5	125	95	3.2	18	9.0	16016	8.5	8.9	
ANF 70	ANR 60	4700	550	1750	70	170	90	106	140	110	1.1	20	9.0	16018	13.0	13.5	
ANF 80	ANR 80	8000	500	1600	80	190	105	122	160	125	0.0	20	9.0	16021	18.0	19.0	
ANF 90	ANR 90	13800	450	1450	90	215	120	133	180	140	0.6	24	11.5	16024	25.3	27.2	
ANF 100	ANR 100	15700	350	1250	100	260	140	157	210	150	2.6	28	14.5	16028	42.1	44.5	
ANF 130	ANR 130	27800	250	1000	130	300	160	188	240	180	2.0	32	17.5	16032	65.0	68.0	
ANF 150		35500	200	800	150	320		205	260	180		32	17.5		95.0		
	ANR 8	16	1000	1000	8	37	20	-	30	20	-	6	3.0	-	-	0.1	
	ANR 12	16	1000	1000	12	37	20	-	30	20	-	6	3.0	-	-	0.1	
	ANR 15	62	850	850	15	47	26	-	37	30	-	7	3.5	-	-	0.3	
	ANR 20	150	650	650	20	62	37	-	52	36	-	8	3.5	-	-	0.6	

## Dimensions AEF & AA Series (for b & t on AEF series refer same bore size ANF clutch)

Clutch Size		Nom <sup>(1)</sup> Torque Nm	Max Overrun rpm		Dimensions mm										App. Wt. kg	
AEF	AA		Inner	Outer	dH7	Dn6	D1h7	D4	D3	D5	Z	O	L	S	AEF	AA
AEF 12	AA 12	13	3100	6200	12	37	47	20	38	28	3	5.5	20	4.5	0.11	0.21
AEF 15	AA 15	44	2300	5600	15	47	55	26	45	37	3	5.5	30	4.5	0.30	0.44
AEF 20	AA 20	117	2000	4800	20	62	68	35	58	50	4	5.5	34	5.5	0.55	0.70
AEF 25	AA 25	228	1700	4000	25	80	90	45	78	65	6	5.5	37	6.5	0.98	1.30
AEF 30	AA 30	400	1500	3400	30	90	100	50	87	75	6	6.6	44	6.2	1.50	2.00
AEF 35	AA 35	576	1300	2800	35	100	110	55	96	80	6	6.6	48	3.8	2.00	2.60
AEF 40	AA 40	824	1200	2500	40	110	125	60	108	90	6	9.0	56	3.8	2.80	3.90
AEF 45	AA 45	900	1050	2200	45	120	130	65	112	95	8	9.0	56	3.8	3.30	4.00
AEF 50	AA 50	1720	950	2050	50	130	150	78	132	110	8	9.0	63	5.8	4.20	6.00
AEF 55	AA 55	2140	850	1950	55	140	160	82	138	115	8	11.0	67	3.8	5.20	7.20
AEF 60	AA 60	2800	800	1800	60	150	170	90	150	125	10	11.0	78	7.6	6.80	9.20
AEF 70	AA 70	4650	650	1700	70	170	190	100	165	140	10	11.0	95	7.6	10.50	11.80

Keyways to DIN 6885 sht. 1.

(1) Nominal torque can be exceeded by up to 2.5x for brief periods.

(2) Speeds quoted for oil lubrication. For grease lubrication x0.5.

### Installation

Torque from outer race is transmitted by 2 face mounted keys offset by 180°. The mating bore should be to H7 or F7 tolerance (K7 or H7 for AEF). If keys are not used outer race must be press-fit with housing tolerance K6 (R6 for AEF). Shaft tolerance should be h6 or j6.

### Note

Except ANR Series, these freewheels have no integral bearings. Inner and outer races must be centred and aligned by external bearing support.

# Types AGF and AGFN Roller Ramp Clutches



## Combined Roller Ramp Clutch with Ball Bearings and outer race tapped to accept End Flanges

AGF and AGFN freewheels contain their own bearings, to centre inner and outer races. The outer race is tapped to enable fitting of a range of standard end flanges, but can equally be adapted to fit gears, or other driven equipment to suit special applications. Combination with standard end flanges or flexible couplings provides complete unit, with its own lubrication, enabling easy fitting to drive equipment.

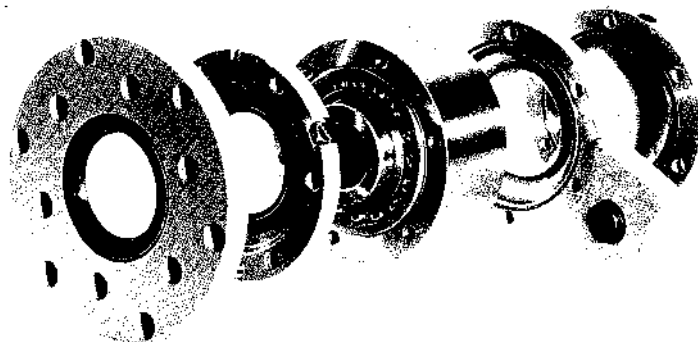

Type AGFN incorporates a keyway in the outer race for torque transmission, enabling simple connection of gears, sprockets and pulleys.

Clutches, with the outer races having through drilled holes instead of tapped holes, are available to order (types ALF & ALFN). These clutches use V ring face contact seals for reduced overrun drag torque, and also permits higher overrun speeds on outer race, and so are particularly suited to high speed indexing and continuous overrun applications.

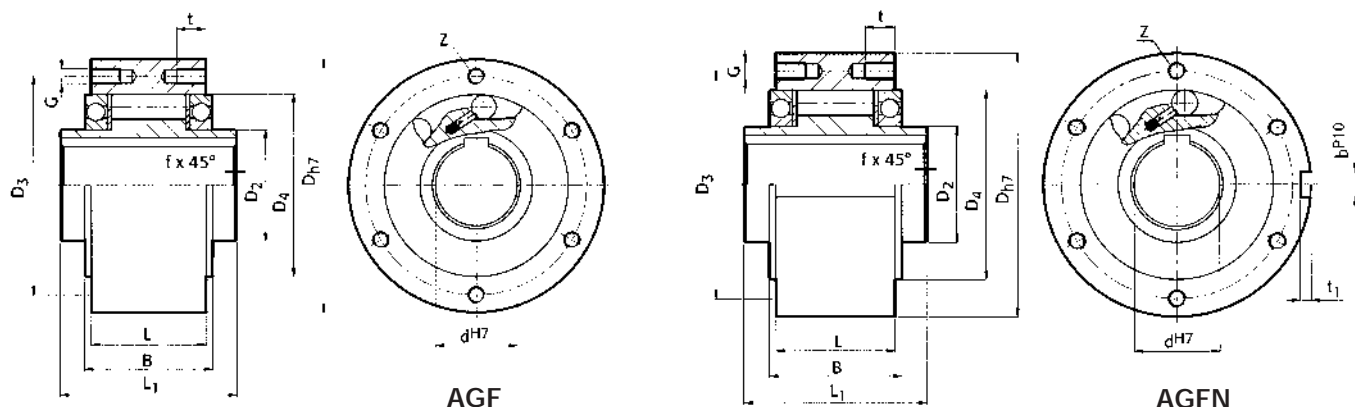

### Dimensions

Clutch Size		Bore mm dH7	Nom Torque Nm <sup>(1)</sup>	Max Overrun Speed <sup>(2)</sup>		Dimensions mm													Approx. Weight kg
Type AGF	Type AGFN			Inner	Outer	Dn7	D2	D4	D3	L1	L	B	t1	bp10	G	t	Z		
AGF 12*	AGFN 12*	12	44	4000	5600	62	20	42	51	42	20	27	2.5	4	ø5.5	-	3	0.5	
AGF 15	AGFN 15	15	100	3600	5200	68	25	47	56	52	28	32	3	5	M5	8	3	0.8	
AGF 20	AGFN 20	20	145	2700	4600	75	30	55	64	57	34	39	3.5	6	M5	8	4	1.0	
AGF 25	AGFN 25	25	230 <sup>+</sup>	2100	3600	90	40	68	78	60	35	40	4	8	M6	10	4	1.5	
AGF 30	AGFN 30	30	400 <sup>+</sup>	1700	3200	100	45	75	87	68	43	48	4	8	M6	10	6	2.2	
AGF 35	AGFN 35	35	580 <sup>+</sup>	1550	3000	110	50	80	96	74	45	51	5	10	M6	12	6	3.0	
AGF 40	AGFN 40	40	820	1150	2600	125	55	90	108	86	53	59	5	12	M8	14	6	4.6	
AGF 45	AGFN 45	45	900	1000	2400	130	60	95	112	86	53	59	5.5	14	M8	14	8	4.7	
AGF 50	AGFN 50	50	1700	800	2150	150	70	110	132	94	64	72	5.5	14	M8	14	8	7.2	
AGF 55	AGFN 55	55	2100	750	2000	160	75	115	138	104	66	72	6	16	M10	16	8	8.6	
AGF 60	AGFN 60	60	2800	650	1900	170	80	125	150	114	78	89	7	18	M10	16	10	10.5	
AGF 70	AGFN 70	70	4600	550	1750	190	90	140	165	134	95	108	7.5	20	M10	16	10	13.5	
AGF 80	AGFN 80	80	6800	500	1600	210	105	160	185	144	100	108	9	22	M10	16	10	18.2	
AGF 90	AGFN 90	90	11600	450	1450	230	120	180	206	158	115	125	9	25	M12	20	10	28.5	
AGF 100	AGFN 100	100	16000	350	1250	270	140	210	240	182	120	131	10	28	M16	24	10	42.5	
AGF 130	AGFN 130	130	25000	250	1000	310	160	240	278	212	152	168	11	32	M16	24	12	65.0	
AGF 150	AGFN 150	150	56000	200	800	400	200	310	360	246	180	194	12	36	M20	32	12	138.0	

(1) Max. Torque = 2.5 Nom. Torque for brief periods only.

(2) For oil lubrication.  
For grease lubrication x0.5.

Shaft keyways to DIN 6885 Sht. 1.

\* Clutch sizes AGF 12 & AGFN 12 have through holes in outer race.

+ Clutch sizes 25, 30 & 35 can be supplied with increased torque design type AGFM for high load indexing applications.

Clutches are supplied with two paper gaskets to fit between the outer race and selected cover plates, to ensure sealing of end covers.

# Types AGF and AGFN Clutches assembled with End Flanges



Combination of AGF Series roller ramp clutches with a selection of end flanges provides a versatile range of clutches complete with own bearing support and integral lubrication system. Flanges can be combined as required to suit most applications, the following combinations being most common.

## AGF-F1-F2

is most popular combination, enabling easy mounting of pulley, sprocket or gear on outer race. F2 flange enables re-lubrication.

## AGF-F2-F7

is designed to enable connection of flexible couplings and universal joints. Can also be used to locate on m/c frame as backstop. In this application F4 cover could be used instead of F2 plate-ref. p. 12.

## AGFN-F5-F6

enables simple fitting of gears, sprockets, pulleys, etc. with positive drive through key on outer race.

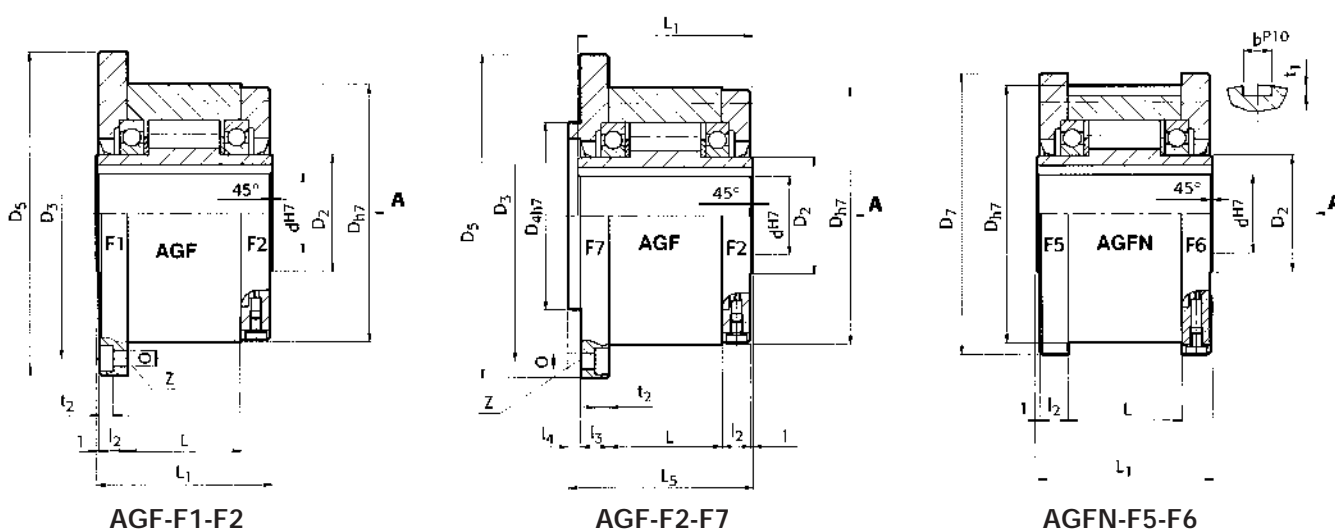

Dimensions (for dimensions D2 refer page 10).

Clutch Sizes AGF or AGFN	Bore mm d <sub>H7</sub>	Nom <sup>(1)</sup> Torque Nm	Max Overrun Speed <sup>(2)</sup>		Dimensions mm																Approx. Wt kg
			inner	outer	D <sub>H7</sub>	D <sub>5</sub>	D <sub>7</sub>	D <sub>3</sub>	D <sub>4H7</sub>	O	t <sub>2</sub>	Z	L <sub>1</sub>	L <sub>5</sub>	L	l <sub>2</sub>	l <sub>3</sub>	l <sub>4</sub>	t <sub>1</sub>	b <sub>P10</sub>	
AGF/AGFN 12	12*	44	3100	4700	62	85	70	72	42	5.5	5.7	3	42	44	20	10	10	3	2.5	4	1.2
AGF/AGFN 15	15	100	2800	4400	68	92	76	78	47	5.5	5.7	3	52	54	28	11	11	3	3	5	1.6
AGF/AGFN 20	20	145	2400	4100	75	98	84	85	55	5.5	5.7	4	57	59	34	10.5	10.5	3	3.5	6	1.9
AGF/AGFN 25	25	230	1600	3800	90	118	99	104	68	6.6	6.8	4	60	62	35	11.5	11.5	3	4	8	2.9
AGF/AGFN 30	30	400	1300	2800	100	128	109	114	75	6.6	6.8	6	68	70	43	11.5	11.5	3	4	8	3.9
AGF/AGFN 35	35	580	1200	2600	110	140	119	124	80	6.6	6.8	6	74	76	45	13.5	13	3.5	5	10	4.9
AGF/AGFN 40	40	820	850	2300	125	160	135	142	90	9	9	6	86	88	53	15.5	15	3.5	5	12	7.5
AGF/AGFN 45	45	900	740	2200	130	165	140	146	95	9	9	8	86	88	53	15.5	15	3.5	5.5	14	7.8
AGF/AGFN 50	50	1700	580	1950	150	185	160	166	110	9	9	8	94	96	64	14	13	4	5.5	14	10.8
AGF/AGFN 55	55	2100	550	1800	160	204	170	182	115	11	11	8	104	106	66	18	17	4	6	16	14.0
AGF/AGFN 60	60	2800	530	1700	170	214	182	192	125	11	11	10	114	116	78	17	16	4	7	18	16.8
AGF/AGFN 70	70	4600	500	1600	190	234	202	212	140	11	11	10	134	136	95	18.5	17.5	4	7.5	20	20.8
AGF/AGFN 80	80	6800	480	1500	210	254	222	232	160	11	11	10	144	146	100	21	20	4	9	22	27.0
AGF/AGFN 90	90	11600	450	1300	230	278	242	254	180	14	13	10	158	160	115	20.5	19	4.5	9	25	40.0
AGF/AGFN 100	100	16000	350	1100	270	335	282	305	210	18	17.5	10	182	184	120	30	28	5	10	28	67.0
AGF/AGFN 130	130	25000	250	900	310	380	322	345	240	18	17.5	12	212	214	150	29	27	5	11	32	94.0
AGF/AGFN 150	150	56000	200	700	400	485	412	445	310	22	21.5	12	246	248	180	32	30	5	12	36	187.0

(1) Max. Torque = 2.5 Nom. Torque for brief periods only.  
Shaft keyways all to DIN 6885 Sht. 1.

(2) Speeds for oil lubrication.  
For grease lubrication x0.55.

Clutches and flanges normally supplied unassembled. If a clutch is required to be supplied assembled, please indicate direction of rotation viewed direction "A".

"R" - inner race overruns clockwise direction.  
"L" - inner race overruns anticlockwise direction.

### Note:

All clutches are supplied without lubrication, and must be suitably filled prior to operation.

If required, flanges can be supplied separately - Please stipulate flange, clutch size and flange reference:- eg "AGF20F2 flange".

# Type AGF Clutch assembled with Torque Arm End Flange



The combination of an AGF series roller ramp clutch with F3 and F2/F4 flanges provide a unit complete with support bearing and its own integral lubrication system. The units are primarily intended for backstop applications, but can also be used as reciprocating arm on indexing applications.

When used as a backstop, outer race rotation is prevented by cam bolt, which by its shape compensates for misalignment. The bolt must be radially free in its location to avoid loading the bearings, so preferred location is with a slot of width 0.5mm above bolt dia. "C".

Higher torque clutches for 25-35mm shafts can be supplied to special order.

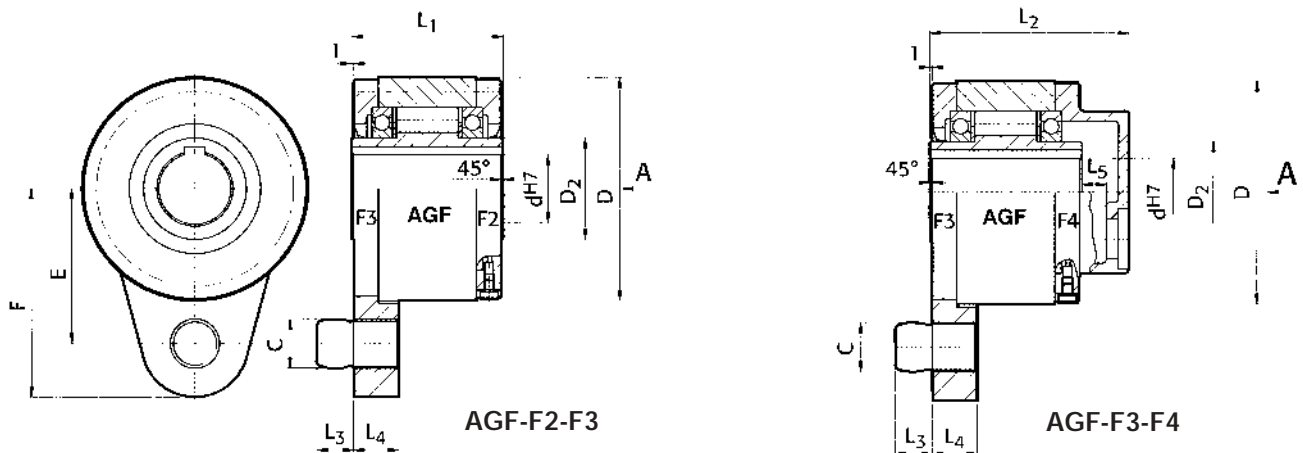

## Dimensions

Clutch Size	Bore mm dH7	Nom <sup>(1)</sup> Torque Nm	Maximum Overrun Speed <sup>(2)</sup>	Dimensions mm											Approx. Weight kg
				D	D <sub>2</sub>	C	L <sub>1</sub>	L <sub>2</sub>	L <sub>3</sub>	L <sub>4</sub>	F	E	L <sub>5</sub>	f	
AGF 12	12	44	3100	62	20	10	42	64	10	13	59	44	6	0.5	1.4
AGF 15	15	100	2800	68	25	10	52	78	10	13	62	47	10	0.8	1.8
AGF 20	20	145	2400	75	30	12	57	82	11	15	72	54	10	0.8	2.3
AGF 25	25	230	1600	90	40	16	60	85	14	18	84	62	10	1.0	3.4
AGF 30	30	400	1300	100	45	16	68	95	14	18	92	68	10	1.0	4.5
AGF 35	35	580	1200	110	50	20	74	102	18	22	102	76	12	1.0	5.6
AGF 40	40	820	850	125	55	20	86	115	18	22	112	85	12	1.5	8.5
AGF 45	45	900	740	130	60	25	86	115	22	26	120	90	12	1.5	8.9
AGF 50	50	1700	580	150	70	25	94	123	22	26	135	102	12	1.5	12.8
AGF 55	55	2100	550	160	75	32	104	138	25	30	142	108	15	2.0	16.2
AGF 60	60	2800	530	170	80	32	114	147	25	30	145	112	15	2.0	19.3
AGF 70	70	4600	500	190	90	38	134	168	30	35	175	135	16	2.5	23.5
AGF 80	80	6800	480	210	105	38	144	178	30	35	185	145	16	2.5	32
AGF 90	90	11600	450	230	120	50	158	192	40	45	205	155	16	3.0	47.2
AGF 100	100	16000	350	270	140	50	182	217	40	45	230	180	16	3.0	76
AGF 130	130	25000	250	310	160	68	212	250	55	60	268	205	18	3.0	110
AGF 150	150	56000	200	400	200	68	246	286	55	60	325	255	20	4.0	214

(1) Max. Torque = 2.5 Nom. Torque for brief periods only.  
Shaft keyways all to DIN 6885 Sht. 1.

(2) Speeds for oil lubrication.  
For grease lubrication x0.5.

Clutches and flanges normally supplied unassembled. If a clutch is required to be supplied assembled, please indicate direction of rotation viewed direction "A".

"R" - inner race overruns clockwise direction.

"L" - inner race overruns anticlockwise direction.

### Note:

All clutches are supplied without lubrication, and must be suitably filled prior to operation.

If required, flanges can be supplied separately - Please stipulate flange, clutch size and flange reference:- eg "AGF30F3 flange".

# Types AGF and ALF Overrunning Clutch Couplings



**Roller Ramp Clutch complete with one bearing support and lubrication system combined with rubber element flexible coupling for shaft-to-shaft drives.**

These clutch couplings consists of AGF/ALF type roller ramp clutches fitted with F2 end flange for lubricating, combined with a high speed rubber element coupling. Dependent on torque requirements two sizes of coupling are available for most clutches.

These clutch couplings are to connect shafts used with overrun applications. The rubber flexible element reduces vibration and compensates for alignment errors up to 0.7° angular ±1.0mm axial and 0.5% coupling dia. (D7) parallel. Only maintenance of oil levels in the clutch (including filling before use) is required. If required, rubber elements can be replaced with coupling in situ (except sizes 4SF & 6.3SF). Two sizes of couplings are available, the smaller ES series being most popular, with KS series used for higher torque applications. Two series of clutches are available; AGF (std. stock to 60mm) with F2 flanges with lip seals limiting speeds, or ALF series with P2 flanges using 'V' ring face seals for higher overrun speeds. Selection of clutch coupling should always be made so the coupling shaft overruns. For high speed continuous overrun applications, clutches with centrifugal lift-off sprags should be considered - refer page 21.

All freewheel couplings are typically used on fans, pumps, starter drives, Sunday drives and dual drive conveyors.

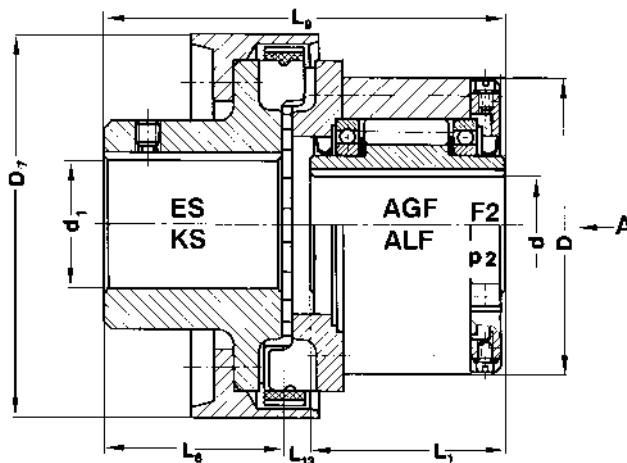
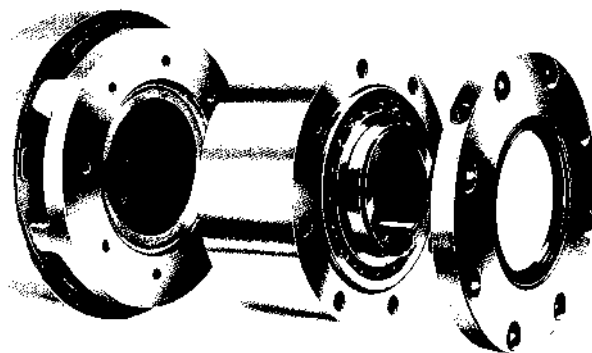

Coupling Clutch Size <sup>(1)</sup>	Flexible Coupling Ref.	Coupling Torque Rating TR <sup>(4)</sup>	Clutch Nominal Torque TN <sup>(4)</sup>	Max <sup>(2)</sup> Overrun Speed Coupling	Max <sup>(2)</sup> Overrun Speed Clutch	Clutch Bore Dia.	Coupling Bore <sup>(3)</sup>		Dimensions mm						Approx. Weight
							Min	Max	Dh7	D7	L1	L6	L9	L13	
AGF 12-ES	4SF	63	44	4700	3100	12	10	35	62	70*	42	40	99	17	2.1
AGF 15-ES	4SF	63	100	4400	2800	15	10	35	68	70*	52	40	110	18	2.5
AGF 20-ES	4SF	63	145	4100	2400	20	10	35	75	70*	57	40	116	19	2.7
AGF 20-KS	10SF	160	145	4100	2400	20	12	45	75	113	57	48	124	19	3.8
AGF 25-ES	6.3SF	100	230	3800	1600	25	12	40	90	82*	60	45	123	18	4.2
AGF 25-KS	10SF	160	230	3800	1600	25	12	40	90	114	60	45	127	19	4.4
AGF 30-ES	10SF	160	400	2800	1300	30	12	45	100	114	68	48	134	18	5.0
AGF 30-KS	16SF	250	400	2800	1300	30	12	50	100	127	68	52	140	20	5.9
AGF 35-ES	16SF	250	580	2600	1200	35	12	50	110	127	74	52	144	18	6.6
AGF 35-KS	25SF	400	580	2600	1200	35	15	55	110	143	74	57	155	24	8.1
AGF 40-ES	25SF	400	820	2300	850	40	15	55	125	143	86	57	164	21	9.1
AGF 40-KS	40SF	630	820	2300	850	40	18	60	125	158	86	61	173	26	11.4
AGF 45-ES	40SF	630	900	2200	740	45	18	60	130	158	86	61	173	26	11.3
AGF 45-KS	63SF	1000	900	2200	740	45	20	70	130	181	86	67	186	33	13.3
AGF 50-ES	63SF	1000	1700	1950	580	50	20	70	150	181	94	67	193	34	16.7
AGF 50-KS	100SF	1600	1700	1950	580	50	28	75	150	202	94	75	210	41	19.1
AGF 55-ES	100SF	1600	2100	1800	550	55	28	75	160	202	104	75	216	37	20.4
AGF 60-ES	100SF	1600	2800	1700	530	60	28	75	170	202	114	75	227	38	24.0
AGF 60-KS	160SF	2500	2800	1700	530	60	32	80	170	230	114	82	243	47	27.1
AGF 70-ES	160SF	2500	4600	1600	500	70	32	80	190	230	134	82	262	46	32.5
AGF 70-KS	250SF	4000	4600	1600	500	70	38	90	190	257	134	89	278	55	40.4
AGF 80-ES	250SF	4000	6800	1500	480	80	38	90	210	257	144	89	285	52	44.2
AGF 80-KS	400SF	6300	6800	1500	480	80	45	100	210	294	144	97	305	64	57.0
AGF 90-ES	400SF	6300	11600	1300	450	90	45	100	230	294	158	97	320	65	65.0
AGF 90-KS	630SF	10000	11600	1300	450	90	65	120	230	332	158	116	347	73	87.0
AGF 100-ES	630SF	10000	16000	1100	350	100	65	120	270	332	182	116	361	63	104.0
AGF 100-KS	1000SF	16000	16000	1100	350	100	80	140	270	382	182	140	386	64	131.0
AGF 130-KS	1600SF	25000	25000	900	250	130	90	160	310	432	202	160	458	96	196.0
AGF 150-ES	1600SF	25000	56000	700	200	150	90	160	400	432	246	160	493	87	282.0

- For clutch sizes AGF12 to 60, type ALF can be supplied to order, for oil lubricated clutches where higher overrun speeds are required.
- For oil bath lubrication.  
For grease lubrication x0.5.
- When ordering please state bore diameter, keyway and setscrew requirements for coupling half. Also indicate direction viewed from 'A' towards F2.  
"R" - inner race overruns clockwise direction.  
"L" - inner race overruns anticlockwise direction.

- For applications where clutch is normally overrunning, such as starter drives, selection is controlled by coupling torque rating TR which should never be less than max. starting torque. For constant drive applications selection is dependent on peak torques seen by coupling and selection is by service factor. All shafts should be manufactured to h6 or j6 tolerances. Prior to assembly align shafts accurately to minimise couplings loads. All couplings are intended for horizontal application. For other requirements consult Clutch Technical Department.

\*Dimension without retaining cap.

Clutch keyways all to DIN 6885 Sht. 1.

# Types KI, ASK and GFK Compact Freewheel Clutches



These three series of Freewheels are ideally suited to volume production machines, combining compact design with low price.

## Type KI - Miniature Roller Ramp Freewheel

The KI Series are self-contained units with inner race, springs and rollers contained in a polyamide cage suitable for temperature range -40°C to +120°C. Designed for small office Equipment and packaging machines, the clutch can be pressed onto shaft to r6 tolerance, with outer driving any steel component with H7 tolerance bore and bearing support.

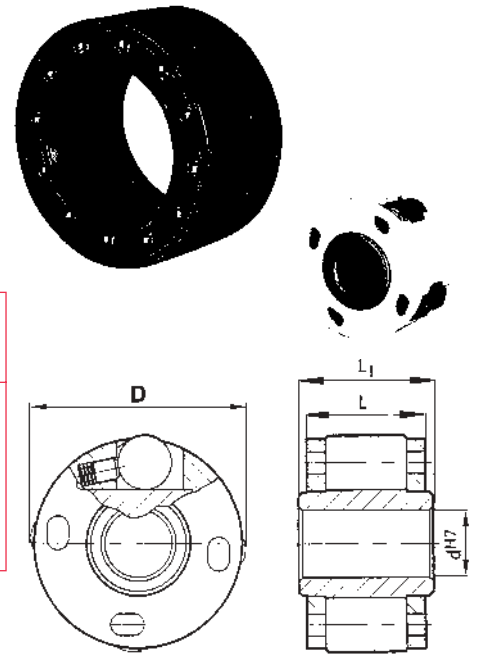

Clutch Size	Bore d <sub>H7</sub> mm	Nom. <sup>(1)</sup> Torque Nm	Max. Overrun Speeds rpm		Dimensions mm			Approx. Weight gms
			Inner	Outer	D <sub>H7</sub>	L <sub>1</sub>	L	
KI 164	4	0.6	8000	10000	16	10	9	8
KI 165	5	0.6	8000	10000	16	10	9	7
KI 194	4	0.7	7000	9000	19	10	9	12
KI 195	5	0.7	7000	9000	19	10	9	11
KI 196	6	0.7	7000	9000	19	10	9	10
KI 268	8*	2.3	5000	6000	26	14	13	23
KI 269	9*	2.3	5000	6000	26	14	13	21
KI 2610	10*	2.3	5000	6000	26	14	13	19

(1) Max. Torque = Nom. Torque, brief periods.

\*Sizes 268-2610 can be supplied with keyway to DIN 6885 sht. 1.

## Type ASK - Combined Roller Bearing and Roller Ramp Clutch

The ASK series are roller ramp freewheels supported by two rows of roller bearings, the complete unit being within a dust proof enclosure conforming to 60 series bearing dimensions. They are supplied ready grease lubricated. Torque transmission is by press fit with outer housing to K6 tolerance and shaft to h6 or j6. These units must not be subject to axial loading.

Clutch Size	Bore d <sub>p6</sub> mm	Brg. Size	Nom. Torque Nm <sup>(1)</sup>	Max. Overrun rpm	D mm	L mm	Bearing Capacity N		Approx. Weight kg
							dyn. C	Stat. Co	
ASK 40	40	6008	58	3500	68	15	16200	20600	0.25
ASK 50	50	6010	100	3000	80	16	19600	23500	0.34
ASK 60	60	6012	200	2500	95	18	25300	35100	0.50

(1) Max. Torque = Nom. Torque, brief periods.

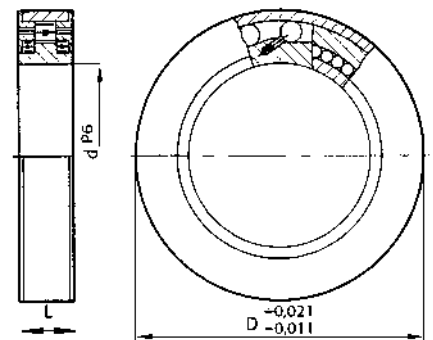

## Type GFK - Ball and Roller Bearing Sprag Clutches

The GFK clutch combines a sprag unit with a roller bearing and ball bearing into a unit which dimensionally equates to a 59 series bearing. The design provides high torque capacity and bearing strength within a compact unit.

Torque transmission is by press fit with outer housing bore to R6 tolerance and shaft to p5 tolerance.

The unit has operating temperature range of -40°C to +130°C, and is supplied ready grease lubricated. For dusty environment external sealing is required.

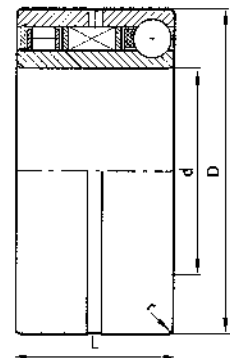

Clutch Size	Bore d mm	Nom. Torque Nm	Max. Overrun Speeds rpm		Equiv. Size Bearing	Bearing Capacities N				Dimensions mm			Approx. Weight kg
			inner	outer		Dynamic C		Static C		D	L	r	
						Roller	Ball	Roller	Ball				
GFK 20	20	41	5500	4000	5904	5600	4400	2900	2750	37	23	0.5	0.09
GFK 25	25	52	5300	3800	5905	6300	5300	3450	3350	42	23	0.5	0.11
GFK 30	30	62	5000	3500	5906	7700	5500	4600	3650	47	23	0.5	0.13
GFK 35	35	106	4600	3200	5907	8200	8500	5200	5700	55	27	1	0.20
GFK 40	40	148	4200	3000	5908	8650	8300	5750	5700	62	30	1	0.30
GFK 45	45	220	3800	2500	5909	9200	9650	6350	7200	68	30	1	0.34
GFK 50	50	240	3400	2200	5910	9650	10000	6950	7800	72	30	1	0.36

(1) Max. Torque = 2.5x Nom. Torque, brief periods.

# Single Revolution Clutches



These clutches have rollers contained in a cage which is connected to the operating cam. The cam is sprung loaded to push the rollers up the ramp to provide drive, but if the cam is stopped by a trip pawl it fires the rollers out of engagement, thereby disengaging the drive. Clutches can provide a single revolution, multiple revolutions or a fraction of a revolution from a constantly rotating input. Extremely accurate positional control is provided with no accumulative error. Two types of clutch are offered - the BAT series for maximum torque capacity, and CTK series for higher speed applications and replacement on existing machinery.

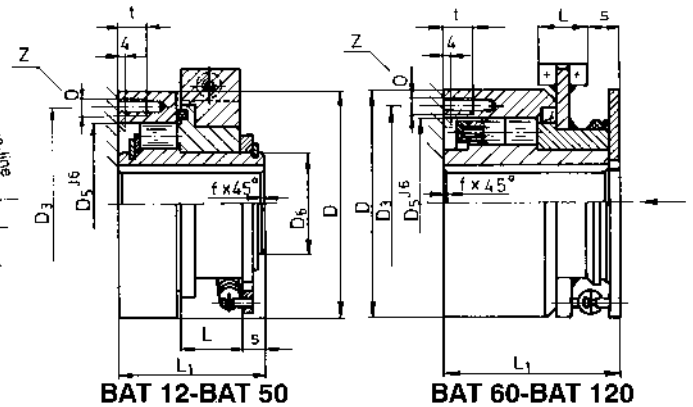
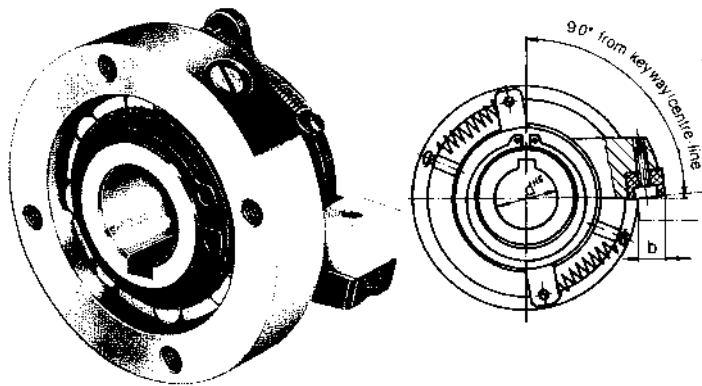
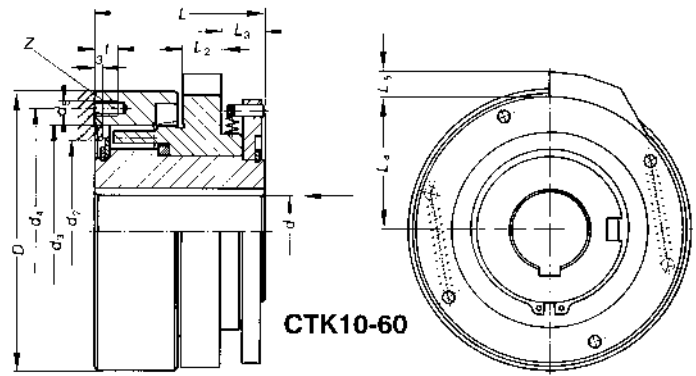

## Dimensions - BAT Series

Clutch Size	Bore $d_{h6}$ mm	Rated Torque <sup>(1)</sup> Nm	Max. Operating Speed rpm	Dimensions mm													Approx. Weight Kg
				D	D <sub>3</sub>	D <sub>5,6</sub>	D <sub>6</sub>	D <sub>7</sub>	L	L <sub>1</sub>	z	o	t	s	b	f	
BAT 12	12	19	750	56	45	37	22	-	12	32	3	M5	7	7	5.0	0.5	0.6
BAT 20	20	60	650	72	61	50	32	-	16	40	4	M5	8	8	7.0	0.8	1.1
BAT 25	25	53	620	72	61	50	37	-	16	40	4	M5	8	8	7.0	1.0	1.1
BAT 30	30	240	560	108	95	75	50	-	26	60	6	M5	10	10	10.0	1.0	4.0
BAT 40	40	370	410	126	108	90	60	-	32	70	6	M8	12	11	10.0	1.5	6.0
BAT 50	50	700	400	152	132	110	75	-	38	80	8	M8	12	11	13.0	1.5	10.0
BAT 60	60	2750	210	195	175	155	-	195	25	120	12	M10	15	22	12.0	2.0	31.0
BAT 70	70	2750	210	195	175	155	-	195	25	120	12	M10	15	22	12.0	2.5	30.0
BAT 80	80	7000	200	250	225	200	-	250	45	140	12	M12	15	22	25.0	2.5	72.0
BAT 90	90	7000	200	250	225	200	-	250	45	140	12	M12	15	22	25.0	3.0	70.0
BAT 100	100	11500	170	315	285	255	-	315	55	160	12	M16	20	16	33.0	3.0	124.0
BAT 120	120	11500	170	315	285	255	-	315	55	160	12	M16	20	16	33.0	4.0	120.0

## Dimensions - CTK Series

Clutch Size	Bore $d_{h7}$ mm	Rated Torque <sup>(1)</sup> Nm	Inertia $kgm^2$	Max. Operating Speed rpm	Dimensions mm													Approx. Weight Kg
					D <sub>h6</sub>	d <sub>2Min</sub>	d <sub>3H7</sub>	d <sub>4</sub>	Z	d <sub>5</sub>	t	L	L <sub>2</sub>	L <sub>3</sub>	L <sub>4</sub>	L <sub>5</sub>		
CTK 10	10	14	0.00025	900	55	28	35	45	4	M4	7	43	12	12	26	7	0.8	
CTK 15	15	21	0.0005	800	62	36.5	42	52	5	M5	7.5	43	12	11	31.5	7	1.2	
CTK 20	20	60	0.0012	700	75	42	52	64	6	M5	9	62	13	15	36	7	1.8	
CTK 30	30	160	0.011	450	120	72	85	102	6	M6	11	80	17	18	58	10	5.8	
CTK 40	40	420	0.042	350	155	100	120	136	8	M8	13	108	26	24	74	14	13.2	
CTK 50	50	650	0.089	300	185	120	140	162	8	M10	15	113	26	30	90	14	19.6	
CTK 60	60	1150	0.193	260	218	150	170	195	10	M10	17	128	30	32	105	16	31.0	

(1) Torque not to be exceeded.  
Note: Torque due to accelerating masses usually determines clutch selection.

When ordering, please specify direction of rotation seen from arrow "A".  
"R" - Clockwise rotation.  
"L" - Counterclockwise rotation.

The units have no bearings and outer driving race (Item 1) must be supported to maintain concentricity with shaft within 0.01mm.

Single revolution freewheel clutches are supplied unlubricated. Lubrication is required prior to operation. We recommend use of Variotrac 68 oil or CAM 916 grease for positive operation.

Keyways: to DIN 6885/1.

Torque is transmitted from the inner race to the shaft via a feather key. We recommend shaft tolerance h6 or j6.  
For BAT clutches the driving race is centred on D5, and for CTK series on d3 with locating spigot to h6 tolerance.

For correct operation it is essential that the trip pawl is rigidly located, and moves in the direction of clutch rotation in disengage motion. A backstop clutch should always be used with a single revolution clutch to prevent recoil engagement, and a forward lock clutch may be required on reciprocating drives.

# Industrial Ratchet Freewheels and Adaptors



Industrial Ratchet Freewheels provide positive one-way drive with high torque capacity within a small unit. A ratchet and pawl mechanism is used with materials and heat treatment selected for a long operating life, with safe, positive transmission. IRF's are suited to low speed (up to 150 r.p.m.) overrun applications where shock loads may be encountered, such as Agricultural machinery. Standard stock units are available in two configurations; as standard sprocket for 1/2 inch pitch chains, or with a drilled flange to fit conveyor rollers, pulleys, or wheels. Standard units have threaded bore to cycle standards, but a range of Adaptors enable fitting to keyed shafting. IRF clutches are also stocked in part-assembled condition for reworking to custom design, including finish parallel bore and keyseat. Many special Industrial Ratchet Freewheels have been manufactured to meet customers' requirements with torques over 1,000 Nm.

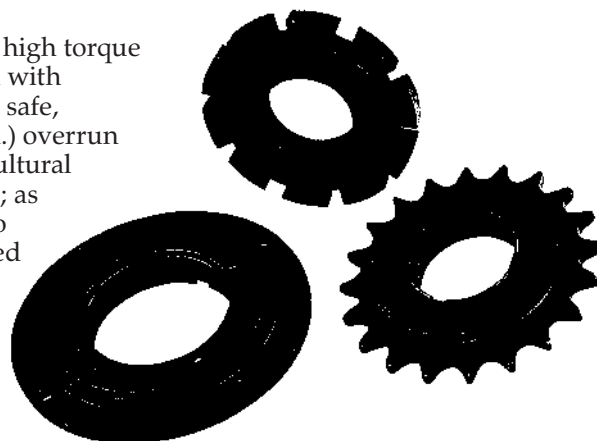

## I.R.F. Clutches with external mounting flange

Dimensions in mm

Freewheel Size	Threaded Bore Diameter <sup>(1)</sup>		Shroud Diameter B	P.C.D. Holes C	Hole Diameter D	Outside Diameter E	Body Width F	Flange Width G	Overall Width H	Torque Capacity Nm	Standard Adaptor Size
	ins	mm									
M.P.F.	0.970	24.64	46.7	54.8	4.9	62.5	11.4	2.9	12.8	42	F11
R.S.J.	1.370	34.80	62.7	69.8	5.2	77.8	13.7	2.9	15.2	150	A211
N.V.F.	2.000	50.80	82.5	94.4	4.9	105.0	13.7	4.4	15.9	206	A213

(1) M.P.F. Clutch bore threaded 20 T.P.I. B.S.W. R.H. Form. R.S.J. and N.V.F. threaded 24 T.P.I. C.E.I. R.H. Form.

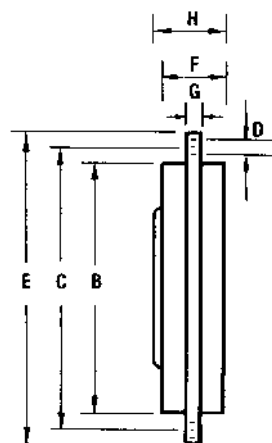

I.R.F. Flange

## I.R.F. Sprockets to suit standard BS Series Chains

Dimensions in mm

Freewheel Size	Chain Size	No. Teeth	Threaded Bore Diameter <sup>(1)</sup>		Shroud Dia. B	P.C.D. of Sprocket	O.D. Sprocket E	Tooth Width G	Body Width F	Overall Torque H	Nominal Torque Nm	Standard Adaptor Size
			ins	mm								
F10B 14	081	14	0.970	24.64	46.7	57.1	64.8	2.9	11.4	12.8	42	F11
A10A 16	081	16	1.370	34.80	54.8	65.1	71.5	2.9	13.7	16.0	106	A211
A10A 17	081	17	1.370	34.80	54.8	69.1	76.0	2.9	13.7	16.0	106	A211
A10A 18	081	18	1.370	34.80	62.2	73.1	78.8	2.9	13.7	16.0	150	A211
A10A 19	081	19	1.370	34.80	65.5	77.2	82.3	2.9	13.7	16.0	150	A211
A10A 20	081	20	1.370	34.80	65.5	81.2	86.4	2.9	13.7	16.0	150	A211
A10A 21	081	21	1.370	34.80	65.5	85.2	92.2	2.9	13.7	16.0	150	A211
A10A 22	081	22	1.370	34.80	65.5	89.2	96.1	2.9	13.7	16.0	150	A211
A10A 23	081	23	1.370	34.80	65.5	93.3	100.1	2.9	13.7	16.0	150	A211
A10A 24	081	24	1.370	34.80	65.5	97.3	103.1	2.9	13.7	16.0	150	A211
A10A 25	081	25	1.370	34.80	65.5	101.3	108.2	2.9	13.7	16.0	150	A211
A10A 26	081	26	1.370	34.80	65.5	105.3	112.3	2.9	13.7	16.0	150	A211
A10B 16	083	16	1.370	34.80	54.8	65.1	71.5	4.4	13.7	16.0	106	A211
A10B 17	083	17	1.370	34.80	54.8	69.1	76.0	4.4	13.7	16.0	106	A211
A10B 18	083	18	1.370	34.80	62.2	73.1	80.0	4.4	13.7	16.0	150	A211
A10B 19	083	19	1.370	34.80	65.5	77.2	84.1	4.4	13.7	16.0	150	A211
A10B 20	083	20	1.370	34.80	65.5	81.2	88.1	4.4	13.7	16.0	150	A211
A10B 21	083	21	1.370	34.80	65.5	85.2	92.2	4.4	13.7	16.0	150	A211
A10B 22	083	22	1.370	34.80	65.5	89.2	96.1	4.4	13.7	16.0	150	A211
A10B 23	083	23	1.370	34.80	65.5	93.3	100.1	4.4	13.7	16.0	150	A211
A10B 24	083	24	1.370	34.80	65.5	97.3	104.1	4.4	13.7	16.0	150	A211
A10B 25	083	25	1.370	34.80	65.5	101.3	108.2	4.4	13.7	16.0	150	A211
A10B 26	083	26	1.370	34.80	65.5	105.3	112.3	4.4	13.7	16.0	150	A211
H.D. 22	083	22	1.625	41.28	78.5	89.2	96.1	4.4	13.7	16.0	195	A212
H.D. 24	083	24	2.000	50.80	82.5	97.3	104.1	4.4	13.7	16.0	206	A213
A08B 19	08B-1	19	1.370	34.80	63.2	77.2	82.3	7.1	13.7	16.0	150	A211
A08B 20	08B-1	20	1.370	34.80	67.3	81.2	86.4	7.1	13.7	16.0	150	A211
A08B 25	08B-1	25	1.370	34.80	71.4	101.3	106.4	7.1	13.7	16.0	150	A211

(1) All clutches except F10B are with 24 T.P.I. C.E.I.R.H. Threaded Form. F10B Clutch has 20 T.P.I. B.S.W. R.H. Thread.

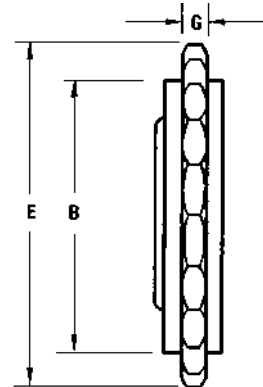

I.R.F. Sprocket

## Steel Adaptors for Industrial Ratchet Freewheels

These adaptors enable easy assembly of standard IRF's to conventional keyed shafting.

Adaptor Size	Top Dia. A	C.E.I. 24 T.P.I. Thread B Dia.		Flange D	Width E
	mm	ins	mm		
F11	27.00	0.966 <sup>(1)</sup>	24.53	11.84	8.73
A211	41.28	1.370	34.80	12.70	14.29
A212	47.63	1.625	41.28	12.70	14.29
A213	57.15	2.000	50.80	12.70	14.29

(1) Adaptor F11 has 20 T.P.I. B.S.W. Thread.

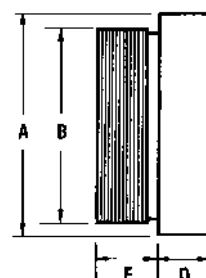

A211/A212/A213

Adaptors are solid bore, (except F11 which has 15mm plain bore) and can be finished bored and keyed to customers specifications. Max. bore = 0.6B.

# Types CR/BW and CR/BV Backstop Clutches



Most types of freewheels can be used for backstop applications, but these clutches have been specially designed for this application. Mainly intended for fitting on Conveyor or Elevator headshafts their design makes easy installation on new or existing units.

CR/BW and BV Series incorporate a torque arm with slot to engage with a bolt fixed to machine frame. Units are greased for life with labyrinth seals ideal for dust laden environments. Units can be mounted on horizontal or vertical shafts, and are available with bore range 20mm to 120mm with torque capacity to 18,450 Nm.

CR/BW Series uses sprags to provide a high torque capacity, at low unit cost. Bearing support is plain metal bushes with seals selected to retain grease and exclude dust and moisture.

CR/BV Series employs roller ramp principle for extended wear life and faster operating speeds. Sealing is by shield protected labyrinth seals. Can be used for slow speed indexing.

When mounting these units it is essential to ensure no axial loading occurs, and there is a minimum 0.2mm clearance around locking pin.

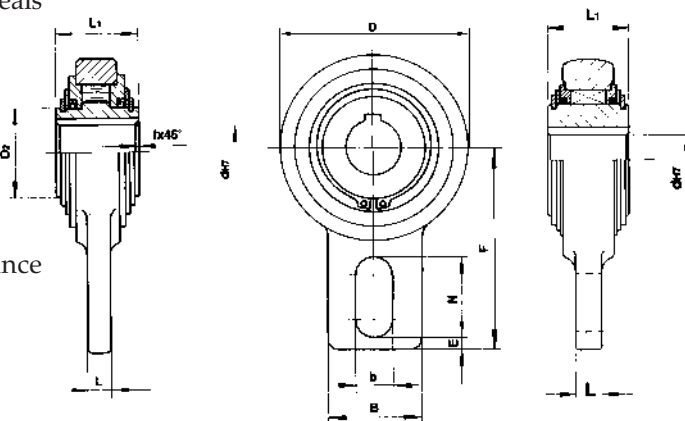
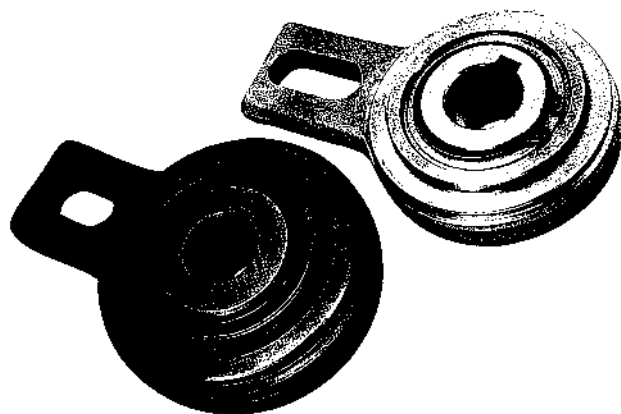

## Dimensions

Clutch Size	Bore dH7 mm	Max. <sup>(1)</sup> Torque Nm	Max. Shaft Speed rpm	Dimensions mm									Approx. Weight kg	Overrun Drag Ncm
				D	D2	L1	L	B	F	b <sup>(2)</sup>	N	E		
CR/BW20	20	750	350	106	-	35	15	40	113	18	35	10.5	2.0	100
CR/BW25	25	1210	300	106	-	48	15	40	113	18	35	10.5	2.6	130
CR/BW30	30	1210	300	106	-	48	15	40	113	18	35	10.5	2.5	130
CR/BW35	35	1210	300	106	-	48	15	40	113	18	35	10.5	2.4	130
CR/BW40	40	2390	250	132	-	52	15	60	125	18	35	10	4.6	200
CR/BW45	45	2390	250	132	-	52	15	60	125	18	35	10	4.5	200
CR/BW50	50	2390	250	132	-	52	15	60	125	18	35	10	4.4	200
CR/BW55	55	2390	250	132	-	52	15	60	125	18	35	10	4.3	200
CR/BW60	60	5100	215	161	-	54	15	70	140	18	35	10	6.5	300
CR/BW70	70	5100	215	161	-	54	15	70	140	18	35	10	6.4	300
CR/BW80	80	9700	200	190	-	70	20	70	165	25	45	15	9.9	450
CR/BW90	90	9700	200	190	-	70	20	70	165	25	45	15	9.8	450
CR/BV20	20	460	450	83	40	35	12	40	90	15	35	5	1.3	18
CR/BV25	25	460	450	83	40	35	12	40	90	15	35	5	1.3	18
CR/BV30	30	2400	320	118	60	54	15	40	110	15	35	8	3.5	130
CR/BV35	35	2400	320	118	60	54	15	40	110	15	35	8	3.4	130
CR/BV40	40	2400	320	118	60	54	15	40	110	15	35	8	3.3	130
CR/BV45	45	3600	280	155	90	54	20	80	140	18	35	10	5.5	240
CR/BV50	50	3600	280	155	90	54	20	80	140	18	35	10	5.4	240
CR/BV55	55	3600	280	155	90	54	20	80	140	18	35	10	5.3	240
CR/BV60	60	3600	280	155	90	54	20	80	140	18	35	10	5.2	240
CR/BV70	70	3600	280	155	90	54	20	80	140	18	35	10	5.0	240
CR/BV80	80	5000	200	190	105	64	20	80	155	20	40	10	8.7	360
CR/BV90	90*	11950	150	260	160	90	25	120	220	-	-	-	24.5	360
CR/BV100	100*	11950	150	260	160	90	25	120	220	-	-	-	23.5	360
CR/BV110	110*	11950	150	260	160	90	25	120	220	-	-	-	22.5	360
CR/BV120	120*	18450	130	300	180	110	30	140	260	-	-	-	42.0	600

(1) This is absolute max. torque clutch should see, including reverse load of motor stall torque due to load. For indexing, torque should be no more than 0.3x this figure.

(2) H11 tolerance CR/BW. B11 tolerance CR/BV series.

\* have 2 keyways offset by 120°. All keyways to DIN 6885 Sht. 1.

# Contact-Free Overrun Clutches

*These are basically similar to conventional sprag clutches, but the sprags have their centre of gravity offset to the pivot point such that in the overrun mode the sprag elements are thrown out of contact with the stationary race by centrifugal force. These clutches are for applications involving long periods of high speed freewheeling, when no wear occurs, such as barring motors, starter drives, pump and motor backstops. Three basic types of unit are available.*

## Types RSBI and RBI

Types RSBI and RBI backstop clutches consist of cylindrical inner and outer races between which are located individually spring loaded, special shape sprag elements contained in a cage. The cage is flexibly connected to the inner race to allow the sprags to engage easily during torque application. When the inner race rotates at high speed the off-centre weight of the elements causes them to rotate within the cage to produce a gap with outer race.

These clutches are designed for backstop applications on the high speed shafts of motors, gearboxes, compressors and pumps. They can also be used within slow speed barring drive. Although basically these clutches require no lubrication, their sprag design does permit the use of E.P. or H.P. additives.

Type RSBI is dimensionally equivalent to many competitor units; type RBI offers higher torque capacity.

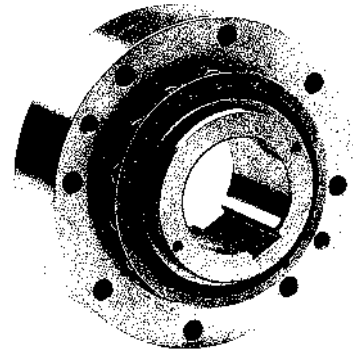

## Types RAZ and RIZ

Types RAZ and RIZ freewheel clutches combine an RSBI sprag cage unit with cylindrical inner and outer races dimensionally equivalent to same reference AGF roller ramp freewheel (ref. p13-14). The outer race is supported on two 60 series ZZ sealed bearings). A range of flanges of same dimensions as AGF series enables fitting of gears, sprockets or pulleys, and units with keyseated outer race can also be provided.

Type RAZ clutches have sprag clutch cage connected to outer race to enable high speed overrunning of the outer race. This series mainly used for overrun applications such as starter drives and barring motors. Type RIZ clutches have sprag clutch cage flexibly connected to the inner race to enable high speed operation of the inner race. Whilst also suitable for overrun applications, more often this series is used as backstop.

Both RAZ and RIZ clutches are available with elastomeric coupling as used with AGF series (refer p13), with RIZ being preferable as these allow whole unit to be stationary during overrun.



## Types CR and RS/BF

Both types CR and RS/BF can only be used as backstops, and are normally mounted on rear of electric motor, or on shaft extension of gearbox. Special shaped sprags are mounted in a cage connected to the outer race, which is of top hat shape to enable connection to rotating shaft. The inner race is flanged to enable connection to machine frame. The two series were originally produced by two different companies, and both have remained in production as they are dimensionally different. The units were the only selection for contact-free backstops, but now the RSBI and RBI series are preferred for new applications.

The CR series units offer the highest torque capacity with 300mm bore units capable of 75,000 Nm torque. Special clutches have been supplied with torques in excess of 150,000 Nm.

Both series have covers available to provide a fully sealed unit.

