

In-house development

Own manufacturing

Sole distributor in Germany

Working with distributors worldwide



**Internal Locking Devices**  
Shaft-Hub-Connection

# Overview



## 3003 plus/ 3003

For low torque transmission  
For medium bending moments



## 3006 plus/ 3006

For medium torque transmission  
For medium bending moments



## 3012

For very high torque transmission  
For high bending moments



## RB, 3015, 3015.1

For medium torque transmission  
For medium bending moments



## 3015 DK

For high torque transmission  
For medium bending moments



## 3015.1 DK

For medium torque transmission  
For medium bending moments



## 3020

For high torque transmission  
Low bending moment takes place via the hub



## 4006

For very high torque transmission  
For very high bending moments



## 8006

For low torque transmission

Overview	2
Description of function	4
Product data	4
Basics-design	5
Basics-Calculation	6
Hub-Calculation	8
<b>3003 plus</b>	<b>12</b>
<b>3003</b>	<b>14</b>
<b>3006 plus</b>	<b>16</b>
<b>3006</b>	<b>18</b>
<b>3012</b>	<b>20</b>
<b>RB</b>	<b>22</b>
<b>3015</b>	<b>24</b>
<b>3015.1</b>	<b>26</b>
<b>3015 DK</b>	<b>28</b>
<b>3015.1 DK</b>	<b>30</b>
<b>3020</b>	<b>32</b>
<b>4006</b>	<b>36</b>
<b>8006</b>	<b>38</b>
Product questionnaire	42
Special design	43
Further products ...	45

# Description of function

## Locking devices of the types TAS ...

The main function of a locking assembly is the safe connection of a shaft to a hub by means of friction. For example, between a shaft and a gear hub. The locking assembly creates a play-free connection by expanding between the shaft and the hub. This type of connection is used mainly for transmitting torque.

It is installed by inserting the locking assembly between the components and the subsequent tightening of the screws. By using conical surfaces, the outer diameter increases and the inner diameter reduces. Radial pressure is built up. The clamping forces are provided and controlled by the screws (force-controlled). This allows the direct compensation of the clearance between shaft and hub.

The supplied locking devices are ready for installation.

To achieve proper operation with a sufficiently high coefficient of friction, the contact surfaces between shaft and hub must be clean and slightly oiled. The functional surfaces of the locking assembly, threads and screw heads are prepared at the factory with oil film.

A detailed installation manual is available on the internet.

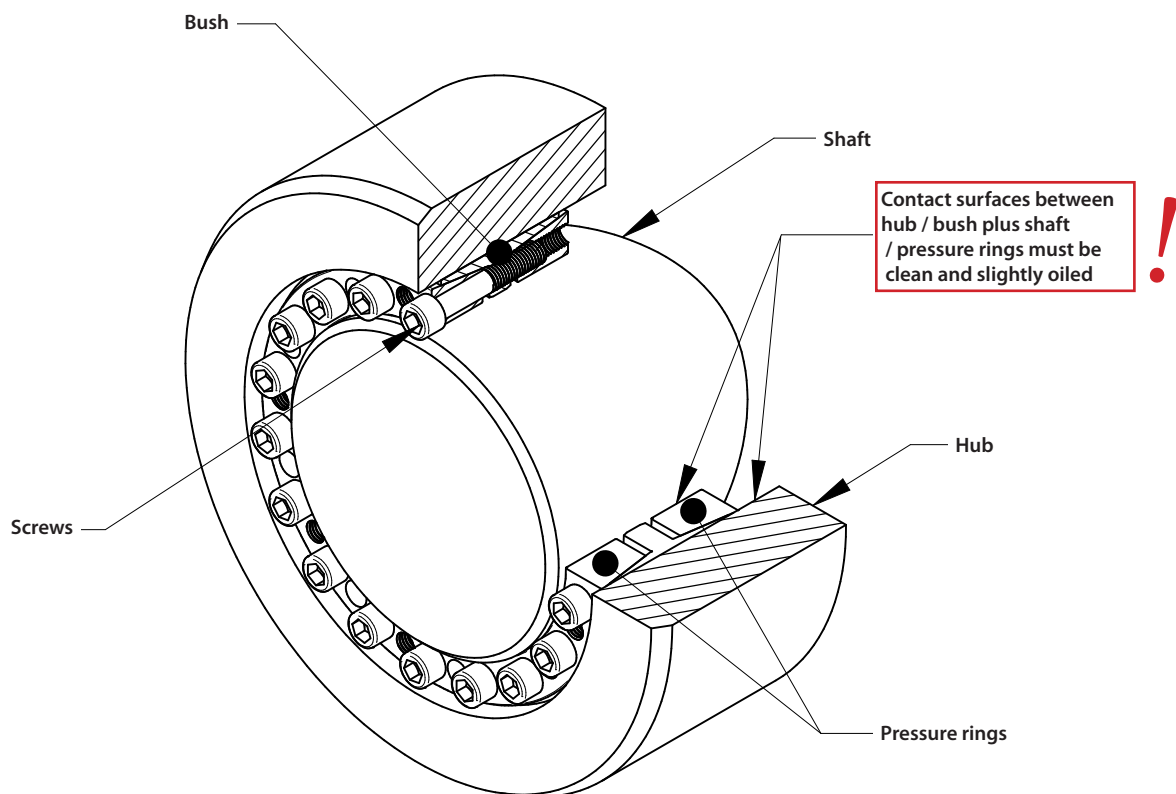

Example: TAS-3015

## Product data

### Data sheets

- Contact us if a datasheet for an individual product is required.

### CAD data

- We provide CAD data for our products in various formats. These can be found online at [www.traceparts.com](http://www.traceparts.com). If the desired product is not available, please contact us directly.

# Basics-design

## Clamping length for locking devices

Pressure rings and bush of a locking device must be fully supported on the shaft and in the hub bore.

## Tightening torque of the clamping screws

The tightening torque values for screws given in the tables are based on a friction  $\mu_{ges} = 0,14$ . Basically the specified tightening torque  $M_A$  can be reduced to  $M_{Agew}$ , to reduce the stresses in the components. When using soft materials, as well as bored shafts, it might become necessary. By reducing  $M_A$ , the pressures of  $P_N$  and  $P_W$  and the transmittable torque  $M$  are also reduced. The ratio is approximately proportional and can be converted accordingly (approximately):

$$M_{gew} = \frac{M_{Agew}}{M_A} M \quad \text{and} \quad p_{N,W} = \frac{M_{Agew}}{M_A} p_{N,W}$$

The tightening torques can not be reduced arbitrary, therefore apply the following limits:

$$M_{Agew} \geq \begin{pmatrix} \text{Class 8.8 : } 0,85 M_A \\ \text{Class 10.9 : } 0,70 M_A \\ \text{Class 12.9 : } 0,60 M_A \end{pmatrix} \leq M_A$$

Locking assemblies of type RB, 3015.1 and 3015.1 DK are excluded because they are already provided with reduced values.

## Tolerances and surfaces

The values found in the product data, base on surface quality and tolerances according to the tables there. These values are given as recommendations.

Higher surface roughness reduces the transmissible torque and promote unwanted settlings. Larger clearance also reduces the transmissible torque.

**In case of significantly differnt values, please contact us!**

The calculation of the values, given in the catalog, are based on the following assumptions and simplification:

## Transmissible torque

A connection by locking assembly is capable of transmitting torque, bending moment and axial force. Alternatively, the transmissible torque  $M_{max}$  is specified in the product data. If such loads occur simultaneously, they must be added vectorially to form a resultant moment  $M_{res}$ . For the resultant moment applies:

$$M_{res} \leq M_{max}$$

At different load cases, these are individually checked against  $M_{max}$ !

$M_{res}$  is determined for combined load as follows:

$$M_{res} = \sqrt{M_T^2 + M_B^2 + (F_{Ax} \frac{d_W}{2})^2}$$

\*Basically the maximum bending moment corresponds to the maximum transmissible torque. A limitation is due to the change of the surface pressure at the edges of the connection, or by the higher loading of the locking assembly itself. Appropriate limits are found under each product. (See also under „bending moment“)

**This results in the following relationships:**

Torque only:

The maximum torque is equivalent to  $M_{max}$ .

Bending moment only:

The Bending moment coresponds with the indicated portion of  $M_T$ , on the product page.

Axial force only:

The maximum axial force is  $M_{max} \frac{2}{d_W}$ .

**Depending on the application, additional safety factors need to be considered for the individual loads!**

# Basics-Calculation

## Radial force

Radial forces cause a change in pressure at the contact surface. In the force direction, the pressure increases on one side and is reduced accordingly on the other side. This depends on the amount of radial force and the rigidity of the parts. The following equation can be used to approximate the pressure change:

$$\Delta p_w = 0,75 \frac{F_{Ax}}{d_w l_k}$$

The modified pressures  $p_{wmin, max}$  results from the following equation:

$$p_{wmin, max} = p_w \pm \Delta p_w$$

The minimum pressure  $p_{wmin}$  should be at least 30 N/mm<sup>2</sup> to avoid gap corrosion. In addition, the material must be selected for a maximum pressure  $p_{wmax}$ .

## Bending moment

Here the situation is similar to the radial forces. The pressure is greatest at the ends of the connection in this case. Again, the amount and stiffness are important. This leads to the following approximation:

$$\Delta p_{w, N} = 4,5 \frac{M_B}{d_w l_k^2}$$

As before, the modified pressures results from:

$$p_{w, N, min, max} = p_{w, N} \pm \Delta p_{w, N}$$

The conditions for minimum and maximum pressure are the same as before. It should be noted that there could be a change in pressure due to radial force!

## Shaft and hub calculation

The catalogue contains information about the generated surface pressure of each locking assembly. Due to the generated radial pressure the hub is deformed, whereupon resilience of the shaft and surface smoothing still has to be added. For solid shafts resilience is negligible but has to be considered for hollow shafts. They are showing greater deformation and therefore greater stresses. This should be considered in addition to the other loads.

The equivalent stresses in the hub can be determined according to various hypotheses such as GEH. On the following pages you will find tables showing required hub sizes, taking pressure, shape and yield strength of hub material into consideration. The shown values for hub sizes are only valid for a solid hub cross-section! The calculation is simplified, includes no additional safety and covers the range of static loads only. Various calculation methods for different cases can be found in mechanical-engineering literature. Specialized software allows the same. For complex geometry reliable results can be determined only by verified FEA.

The minimum yield strength of solid shafts should be at least 2 \*  $P_w$ , the yield point of hub material at least 1 \*  $P_N$ . These values are for orientation only, represent minimum requirements and cannot replace calculations for each application! They also do not release from doing so!

## Notch effect

Generally there is a notch effect on the components, caused by the radial pressure of the locking device. This depends mainly on the applied pressure. On the shaft the notch effect is usually much higher than at the hub, as the pressure is higher here. The factors are in the range of 1.2 to 1.8 at the shaft. This can, for example, be mitigated by appropriate design details, such as relief notches.

## Bore in the shaft (Hollow shaft)

A large bore  $d_b$  in the shaft or use of a hollow shaft, reduces the stiffness of this component against radial pressure. Basically, a bore should not be greater than 0,3  $d_w$ .



# Hub-Calculation

The K-Values can directly be taken from the tables or can be calculated as follows:

$$D_N \geq D \cdot K \quad K = \sqrt{\frac{\sigma_{02} + (C \cdot P_N)}{\sigma_{02} - (C \cdot P_N)}}$$

By applying of TAS Locking assemblies a tension is generated by the surface pressure  $P_N$  between locking assembly and hub. The required hub diameter is calculated using the same formula, as used for thick-walled hollow cylinder. The real tensions depend on the hub length and shape with respect to the length  $L$  of the locking assemblies. Depending on the type of hub, the factor  $C$  is taken into account for calculation.

$B \geq 2L$

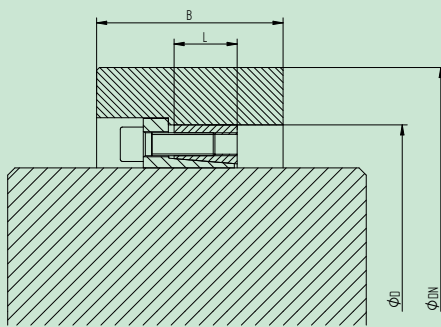

$C = 0,6$

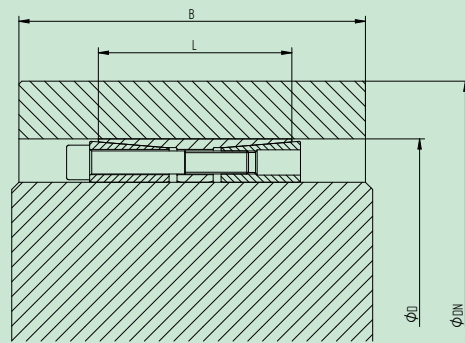

$C = 0,8$

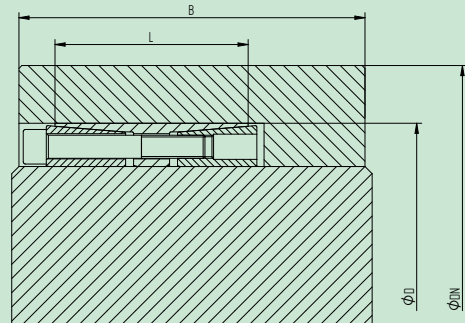
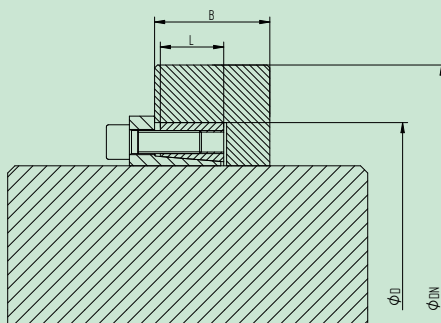

$B \geq L$

$C = 1,0$

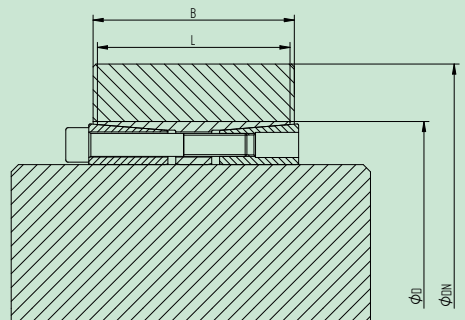
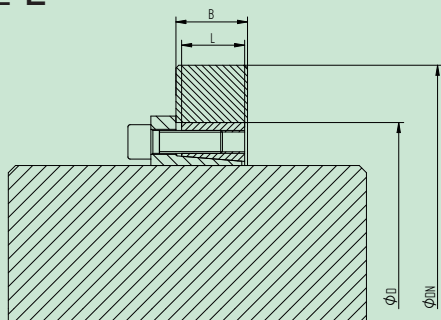

# Hub Outside Diameter

## K-Factor for hubtyp with C = 0,6

$P_N$ N/mm <sup>2</sup>	Yield strenght hubmaterial (N/mm <sup>2</sup> )										
	150	180	210	240	270	300	330	360	390	420	450
50	1,225	1,184	1,155	1,134	1,119	1,106	1,096	1,088	1,081	1,075	1,070
55	1,251	1,204	1,172	1,149	1,131	1,117	1,106	1,097	1,089	1,082	1,077
60	1,278	1,225	1,190	1,164	1,144	1,129	1,116	1,106	1,097	1,090	1,084
65	1,305	1,247	1,207	1,179	1,157	1,140	1,127	1,115	1,106	1,098	1,091
70	1,334	1,269	1,225	1,194	1,170	1,152	1,137	1,125	1,115	1,106	1,099
75	1,363	1,291	1,244	1,209	1,184	1,164	1,148	1,134	1,123	1,114	1,106
80	1,394	1,315	1,262	1,225	1,197	1,176	1,158	1,144	1,132	1,122	1,114
85	1,425	1,339	1,282	1,241	1,211	1,188	1,169	1,154	1,141	1,130	1,121
90	1,458	1,363	1,301	1,258	1,225	1,200	1,180	1,164	1,150	1,139	1,129
95	1,492	1,389	1,322	1,274	1,240	1,213	1,191	1,174	1,159	1,147	1,136
100	1,528	1,415	1,342	1,291	1,254	1,225	1,202	1,184	1,168	1,155	1,144
105	1,565	1,442	1,363	1,309	1,269	1,238	1,214	1,194	1,177	1,164	1,152
110	1,604	1,469	1,385	1,327	1,284	1,251	1,225	1,204	1,187	1,172	1,160
115	1,645	1,498	1,407	1,345	1,299	1,264	1,237	1,215	1,196	1,181	1,168
120	1,688	1,528	1,430	1,363	1,315	1,278	1,249	1,225	1,206	1,190	1,176
125	1,733	1,559	1,453	1,382	1,331	1,291	1,261	1,236	1,215	1,198	1,184
130	1,780	1,591	1,478	1,402	1,347	1,305	1,273	1,247	1,225	1,207	1,192
135	1,830	1,624	1,502	1,421	1,363	1,319	1,285	1,258	1,235	1,216	1,200
140	1,883	1,659	1,528	1,442	1,380	1,334	1,298	1,269	1,245	1,225	1,208
145	1,940	1,695	1,554	1,462	1,397	1,348	1,310	1,280	1,255	1,234	1,217
150	-	1,733	1,582	1,484	1,415	1,363	1,323	1,291	1,265	1,244	1,225
155	-	1,772	1,610	1,506	1,433	1,378	1,336	1,303	1,276	1,253	1,234
160	-	1,813	1,639	1,528	1,451	1,394	1,350	1,315	1,286	1,262	1,242
165	-	1,856	1,669	1,551	1,469	1,409	1,363	1,327	1,297	1,272	1,251
170	-	1,902	1,700	1,575	1,489	1,425	1,377	1,339	1,308	1,282	1,260
175	-	1,950	1,733	1,599	1,508	1,442	1,391	1,351	1,318	1,291	1,269
180	-	-	1,766	1,624	1,528	1,458	1,405	1,363	1,329	1,301	1,278
185	-	-	1,801	1,650	1,548	1,475	1,420	1,376	1,341	1,311	1,287
190	-	-	1,838	1,677	1,569	1,492	1,434	1,389	1,352	1,322	1,296
195	-	-	1,876	1,704	1,591	1,510	1,449	1,402	1,363	1,332	1,305
200	-	-	1,915	1,733	1,613	1,528	1,464	1,415	1,375	1,342	1,315
205	-	-	1,957	1,762	1,636	1,546	1,480	1,428	1,387	1,353	1,324
210	-	-	-	1,792	1,659	1,565	1,496	1,442	1,399	1,363	1,334
215	-	-	-	1,824	1,683	1,584	1,512	1,455	1,411	1,374	1,344
220	-	-	-	1,856	1,707	1,604	1,528	1,469	1,423	1,385	1,353
225	-	-	-	1,890	1,733	1,624	1,545	1,484	1,435	1,396	1,363
230	-	-	-	1,926	1,759	1,645	1,562	1,498	1,448	1,407	1,373
235	-	-	-	1,962	1,785	1,666	1,579	1,513	1,461	1,419	1,383
240	-	-	-	-	1,813	1,688	1,597	1,528	1,474	1,430	1,394
245	-	-	-	-	1,842	1,710	1,615	1,543	1,487	1,442	1,404
250	-	-	-	-	1,871	1,733	1,633	1,559	1,500	1,453	1,415

# Hub Outside Diameter

## K-Factor for hubtyp with C = 0,8

$p_N$ N/mm <sup>2</sup>	Yield strenght hubmaterial (N/mm <sup>2</sup> )										
	150	180	210	240	270	300	330	360	390	420	450
50	1,315	1,254	1,213	1,184	1,161	1,144	1,130	1,119	1,109	1,101	1,094
55	1,353	1,284	1,237	1,204	1,179	1,160	1,144	1,131	1,120	1,111	1,104
60	1,394	1,315	1,262	1,225	1,197	1,176	1,158	1,144	1,132	1,122	1,114
65	1,436	1,347	1,288	1,247	1,216	1,192	1,173	1,157	1,144	1,133	1,124
70	1,481	1,380	1,315	1,269	1,235	1,208	1,187	1,170	1,156	1,144	1,134
75	1,528	1,415	1,342	1,291	1,254	1,225	1,202	1,184	1,168	1,155	1,144
80	1,578	1,451	1,370	1,315	1,274	1,242	1,218	1,197	1,181	1,166	1,154
85	1,631	1,489	1,400	1,339	1,294	1,260	1,233	1,211	1,193	1,178	1,165
90	1,688	1,528	1,430	1,363	1,315	1,278	1,249	1,225	1,206	1,190	1,176
95	1,748	1,569	1,461	1,389	1,336	1,296	1,265	1,240	1,219	1,201	1,186
100	1,813	1,613	1,494	1,415	1,358	1,315	1,281	1,254	1,232	1,213	1,197
105	1,883	1,659	1,528	1,442	1,380	1,334	1,298	1,269	1,245	1,225	1,208
110	1,960	1,707	1,563	1,469	1,403	1,353	1,315	1,284	1,259	1,237	1,220
115	2,043	1,759	1,600	1,498	1,427	1,373	1,332	1,299	1,272	1,250	1,231
120	2,135	1,813	1,639	1,528	1,451	1,394	1,350	1,315	1,286	1,262	1,242
125	2,237	1,871	1,679	1,559	1,476	1,415	1,368	1,331	1,300	1,275	1,254
130	2,350	1,934	1,722	1,591	1,502	1,436	1,386	1,347	1,315	1,288	1,266
135	2,479	2,000	1,766	1,624	1,528	1,458	1,405	1,363	1,329	1,301	1,278
140	2,626	2,073	1,813	1,659	1,555	1,481	1,424	1,380	1,344	1,315	1,290
145	2,798	2,151	1,863	1,695	1,584	1,504	1,444	1,397	1,359	1,328	1,302
150	-	2,237	1,915	1,733	1,613	1,528	1,464	1,415	1,375	1,342	1,315
155	-	2,330	1,971	1,772	1,643	1,553	1,485	1,433	1,391	1,356	1,327
160	-	2,434	2,031	1,813	1,675	1,578	1,506	1,451	1,407	1,370	1,340
165	-	2,550	2,094	1,856	1,707	1,604	1,528	1,469	1,423	1,385	1,353
170	-	2,680	2,163	1,902	1,741	1,631	1,550	1,489	1,440	1,400	1,367
175	-	2,829	2,237	1,950	1,776	1,659	1,573	1,508	1,457	1,415	1,380
180	-	-	2,316	2,000	1,813	1,688	1,597	1,528	1,474	1,430	1,394
185	-	-	2,403	2,054	1,852	1,717	1,621	1,548	1,492	1,446	1,408
190	-	-	2,499	2,111	1,892	1,748	1,646	1,569	1,510	1,461	1,422
195	-	-	2,604	2,172	1,934	1,780	1,672	1,591	1,528	1,478	1,436
200	-	-	2,721	2,237	1,978	1,813	1,698	1,613	1,547	1,494	1,451
205	-	-	2,852	2,306	2,024	1,848	1,726	1,636	1,566	1,511	1,466
210	-	-	-	2,381	2,073	1,883	1,754	1,659	1,586	1,528	1,481
215	-	-	-	2,462	2,124	1,921	1,783	1,683	1,606	1,546	1,496
220	-	-	-	2,550	2,179	1,960	1,813	1,707	1,627	1,563	1,512
225	-	-	-	2,646	2,237	2,000	1,844	1,733	1,648	1,582	1,528
230	-	-	-	2,752	2,298	2,043	1,877	1,759	1,670	1,600	1,544
235	-	-	-	2,869	2,364	2,088	1,910	1,785	1,692	1,619	1,561
240	-	-	-	-	2,434	2,135	1,945	1,813	1,715	1,639	1,578
245	-	-	-	-	2,510	2,184	1,982	1,842	1,738	1,659	1,595
250	-	-	-	-	2,592	2,237	2,020	1,871	1,763	1,679	1,613

# Hub Outside Diameter

K-Factore for hubtyp with C = 1,0											
$P_N$ N/mm <sup>2</sup>	Yield strenght hubmaterial (N/mm <sup>2</sup> )										
	150	180	210	240	270	300	330	360	390	420	450
50	1,415	1,331	1,275	1,236	1,207	1,184	1,165	1,151	1,138	1,128	1,119
55	1,469	1,372	1,308	1,263	1,230	1,204	1,184	1,167	1,153	1,141	1,131
60	1,528	1,415	1,342	1,291	1,254	1,225	1,202	1,184	1,168	1,155	1,144
65	1,591	1,460	1,378	1,321	1,279	1,247	1,221	1,201	1,184	1,169	1,157
70	1,659	1,508	1,415	1,351	1,304	1,269	1,241	1,218	1,199	1,184	1,170
75	1,733	1,559	1,453	1,382	1,331	1,291	1,261	1,236	1,215	1,198	1,184
80	1,813	1,613	1,494	1,415	1,358	1,315	1,281	1,254	1,232	1,213	1,197
85	1,902	1,671	1,537	1,449	1,386	1,339	1,302	1,273	1,248	1,228	1,211
90	2,000	1,733	1,582	1,484	1,415	1,363	1,323	1,291	1,265	1,244	1,225
95	2,111	1,799	1,629	1,520	1,445	1,389	1,345	1,311	1,283	1,259	1,240
100	2,237	1,871	1,679	1,559	1,476	1,415	1,368	1,331	1,300	1,275	1,254
105	2,381	1,950	1,733	1,599	1,508	1,442	1,391	1,351	1,318	1,291	1,269
110	2,550	2,036	1,789	1,641	1,542	1,469	1,415	1,372	1,337	1,308	1,284
115	2,752	2,131	1,850	1,686	1,577	1,498	1,439	1,393	1,356	1,325	1,299
120	3,000	2,237	1,915	1,733	1,613	1,528	1,464	1,415	1,375	1,342	1,315
125	3,317	2,355	1,986	1,782	1,651	1,559	1,490	1,437	1,395	1,360	1,331
130	3,742	2,490	2,062	1,835	1,691	1,591	1,517	1,460	1,415	1,378	1,347
135	4,359	2,646	2,145	1,890	1,733	1,624	1,545	1,484	1,435	1,396	1,363
140	5,386	2,829	2,237	1,950	1,776	1,659	1,573	1,508	1,457	1,415	1,380
145	7,682	3,048	2,337	2,014	1,823	1,695	1,603	1,533	1,478	1,434	1,397
150	-	3,317	2,450	2,082	1,871	1,733	1,633	1,559	1,500	1,453	1,415
155	-	3,661	2,577	2,156	1,923	1,772	1,665	1,585	1,523	1,474	1,433
160	-	4,124	2,721	2,237	1,978	1,813	1,698	1,613	1,547	1,494	1,451
165	-	4,796	2,887	2,324	2,036	1,856	1,733	1,641	1,571	1,515	1,469
170	-	5,917	3,083	2,421	2,098	1,902	1,768	1,671	1,596	1,537	1,489
175	-	8,427	3,317	2,527	2,165	1,950	1,806	1,701	1,622	1,559	1,508
180	-	-	3,606	2,646	2,237	2,000	1,844	1,733	1,648	1,582	1,528
185	-	-	3,975	2,780	2,314	2,054	1,885	1,765	1,675	1,605	1,548
190	-	-	4,473	2,933	2,398	2,111	1,928	1,799	1,703	1,629	1,569
195	-	-	5,197	3,110	2,490	2,172	1,973	1,835	1,733	1,654	1,591
200	-	-	6,404	3,317	2,592	2,237	2,020	1,871	1,763	1,679	1,613
205	-	-	9,111	3,566	2,704	2,306	2,069	1,910	1,794	1,705	1,636
210	-	-	-	3,873	2,829	2,381	2,122	1,950	1,826	1,733	1,659
215	-	-	-	4,267	2,970	2,462	2,177	1,992	1,860	1,760	1,683
220	-	-	-	4,796	3,131	2,550	2,237	2,036	1,895	1,789	1,707
225	-	-	-	5,568	3,317	2,646	2,300	2,082	1,931	1,819	1,733
230	-	-	-	6,856	3,536	2,752	2,367	2,131	1,969	1,850	1,759
235	-	-	-	9,747	3,799	2,869	2,439	2,182	2,009	1,882	1,785
240	-	-	-	-	4,124	3,000	2,517	2,237	2,050	1,915	1,813
245	-	-	-	-	4,539	3,148	2,601	2,294	2,093	1,950	1,842
250	-	-	-	-	5,100	3,317	2,693	2,355	2,139	1,986	1,871

# 3003 plus

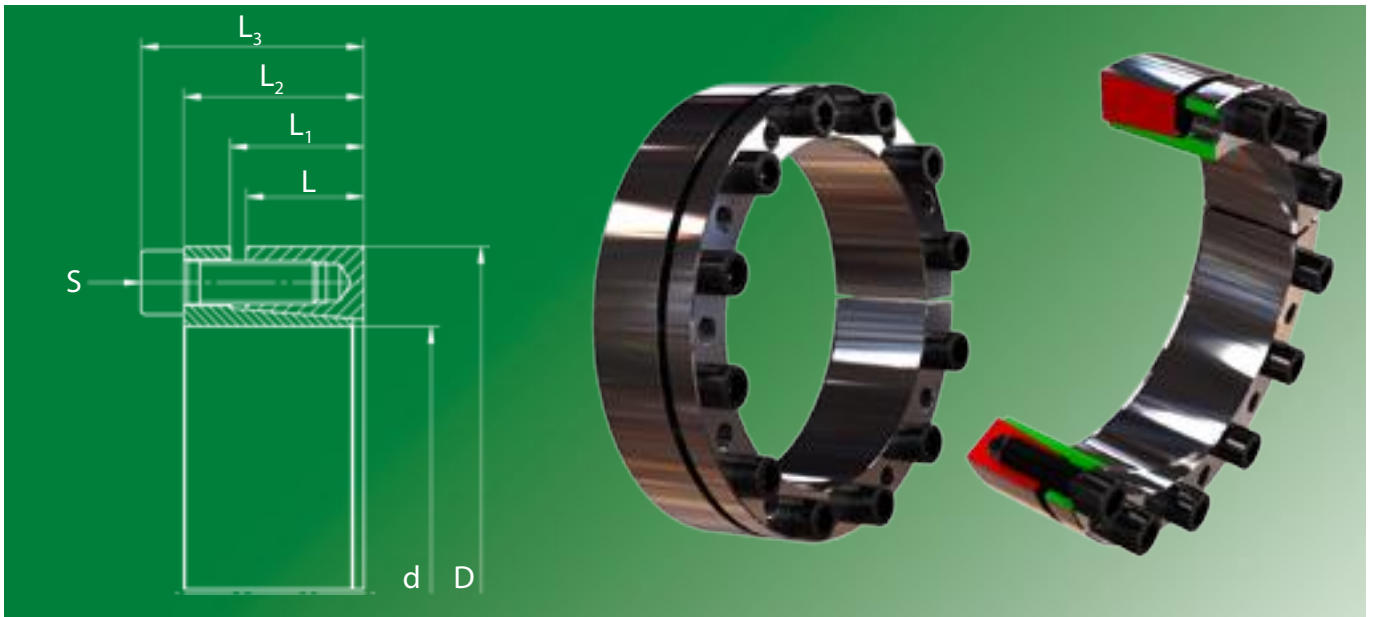

## Used symbols

$d$	[mm]	Shaft diameter	
$D$	[mm]	Hub inside diameter	
$M_t$	[Nm]	Max. transmittable torque	$F_{ax} = 0$
$F_{ax}$	[kN]	Max. transmittable axial force	$M_t = 0$
$p_w$	[N/mm <sup>2</sup> ]	Average pressure on the shaft	
$p_N$	[N/mm <sup>2</sup> ]	Average pressure on the hub	
$L$	[mm]	Length of the pressure ring	
$L_1$	[mm]	Distance of the pressure ring	
$L_2$	[mm]	Width of the locking device without screws	
$L_3$	[mm]	Width of the locking device with screws	
$Z$		Number of clamping screws	
$S$		Size of the clamping screws	
$M_A$		Tightening torque of the clamping screws	

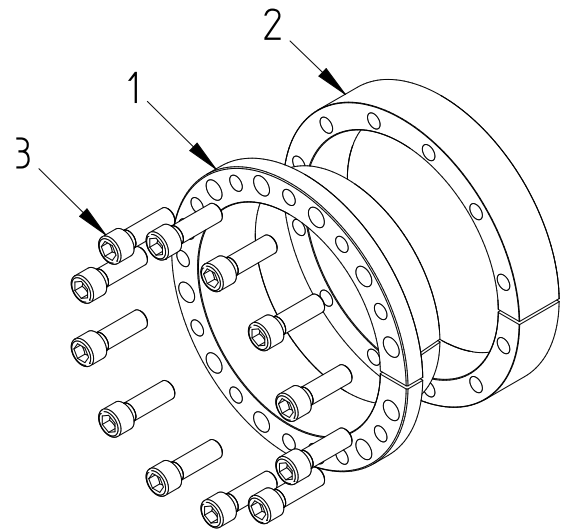

Pos.	Designation
1	Bush
2	Pressure ring
3	Screw

## Recommended tolerances & surfaces

Shaft	Every fit between h11 and k11 / Rz10
Hub	Every fit between H11 and N11 / Rz10

## Bending loads

Bending moment (share)	$M_B \text{ max} = 0,3 * M_t$
Bending angel	max. 5°

## More properties

- axial displacement during assembly
- good self-centering
- low self-locking

Ordering information: TAS 3003 plus/d/D (for example: TAS 3003 plus/150/200 ... further sizes on request)

# 3003 plus

<b>d</b> mm		<b>D</b> mm	<b>M<sub>t</sub></b> Nm	<b>F<sub>ax</sub></b> kN	<b>p<sub>w</sub></b> N/mm <sup>2</sup>	<b>p<sub>N</sub></b> N/mm <sup>2</sup>	<b>Z</b> Stk	<b>S</b>	<b>M<sub>A</sub></b> Nm	<b>L</b> mm	<b>L<sub>1</sub></b> mm	<b>L<sub>2</sub></b> mm	<b>L<sub>3</sub></b> mm	<b>Weight</b> kg
20	x	47	360	36	281	119	5	M6 x 020	14	17	22	28	34	0,26
22	x	47	390	36	255	119	5	M6 x 020	14	17	22	28	34	0,24
24	x	50	430	36	234	112	5	M6 x 020	14	17	22	28	34	0,27
25	x	50	540	43	270	135	6	M6 x 020	14	17	22	28	34	0,27
28	x	55	600	43	241	123	6	M6 x 020	14	17	22	28	34	0,32
30	x	55	640	43	225	123	6	M6 x 020	14	17	22	28	34	0,30
32	x	60	920	58	281	150	8	M6 x 020	14	17	22	28	34	0,37
35	x	60	1000	58	257	150	8	M6 x 020	14	17	22	28	34	0,34
38	x	65	1000	58	236	138	8	M6 x 020	14	17	22	30	36	0,43
40	x	65	1100	58	225	138	8	M6 x 020	14	17	22	30	36	0,40
45	x	75	2400	110	325	195	8	M8 x 025	35	20	25	34	42	0,64
50	x	80	2700	110	293	183	8	M8 x 025	35	20	25	34,5	42,5	0,71
55	x	85	3000	110	266	172	8	M8 x 025	35	20	25	34,5	42,5	0,76
60	x	90	3300	110	244	163	8	M8 x 025	35	20	25	34,5	42,5	0,82
65	x	95	4000	124	253	173	9	M8 x 025	35	20	25	34,5	42,5	0,87
70	x	110	6000	173	274	174	8	M10 x 030	69	24	29	41	51	1,6
75	x	115	6500	173	255	167	8	M10 x 030	69	24	29	41	51	1,7
80	x	120	6900	173	239	160	8	M10 x 030	69	24	29	41	51	1,8
85	x	125	8200	195	254	172	9	M10 x 030	69	24	29	41	51	1,9
90	x	130	8700	195	239	166	9	M10 x 030	69	24	29	41	51	2,0
95	x	135	10200	217	252	177	10	M10 x 030	69	24	29	41	51	2,0
100	x	145	14200	285	291	201	9	M12 x 035	120	26	31	46	58	2,8
110	x	155	15600	285	265	188	9	M12 x 035	120	26	31	46	58	3,0
120	x	165	17100	285	242	176	9	M12 x 035	120	26	32	46	58	3,2
130	x	180	25100	387	232	168	9	M14 x 040	190	34	40	57	71	4,9
140	x	190	27100	387	216	159	9	M14 x 040	190	34	40	57	71	5,2
150	x	200	32200	430	224	168	10	M14 x 040	190	34	40	57	71	5,5
160	x	210	41200	516	252	192	12	M14 x 040	190	34	40	57	71	5,8
170	x	225	43800	516	183	138	12	M14 x 040	190	44	50	67	81	8,2
180	x	235	46400	516	173	132	12	M14 x 040	190	44	50	67	81	8,6
190	x	250	67800	714	227	172	12	M16 x 050	295	44	50	67,5	83,5	10,0
200	x	260	71300	714	215	166	12	M16 x 050	295	44	50	67,5	83,5	10,5
220	x	285	78500	714	172	133	12	M16 x 050	295	50	56	76	92	14,2
240	x	305	107000	892	197	155	15	M16 x 050	295	50	56	76	92	15,3
260	x	325	139000	1071	219	175	18	M16 x 050	295	50	56	76	92	16,4
280	x	355	159000	1136	179	141	16	M18 x 060	405	60	66	88	106	24,1
300	x	375	191000	1278	188	151	18	M18 x 060	405	60	66	88	106	25,6
320	x	405	265000	1660	186	147	18	M20 x 060	580	74	81	104	124	36,9
340	x	425	329000	1937	204	163	21	M20 x 060	580	74	81	104	124	38,9
360	x	455	374000	2081	178	141	18	M22 x 060	780	86	94	120	142	53,5
380	x	475	461000	2428	197	158	21	M22 x 060	780	86	94	120	142	56,1
400	x	495	485000	2428	187	151	21	M22 x 060	780	86	94	120	142	58,7

# 3003

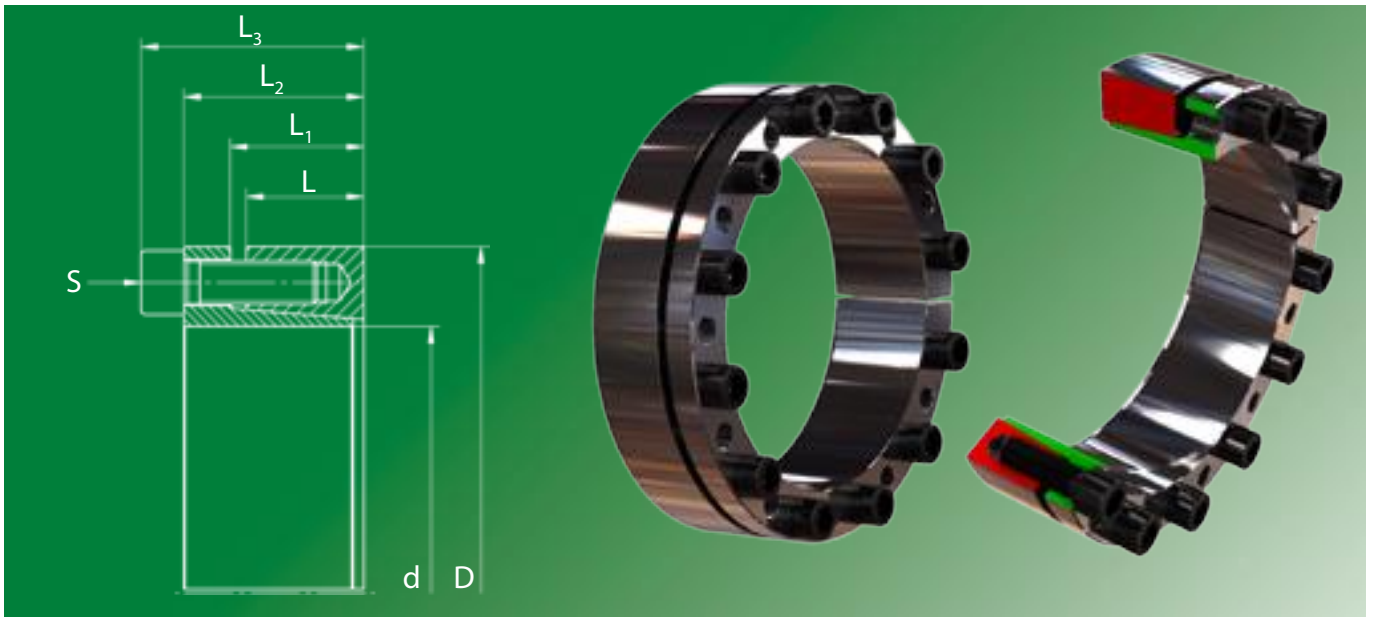

## Used symbols

$d$	[mm]	Shaft diameter	
$D$	[mm]	Hub inside diameter	
$M_t$	[Nm]	Max. transmittable torque	$F_{ax} = 0$
$F_{ax}$	[kN]	Max. transmittable axial force	$M_t = 0$
$p_w$	[N/mm <sup>2</sup> ]	Average pressure on the shaft	
$p_N$	[N/mm <sup>2</sup> ]	Average pressure on the hub	
$L$	[mm]	Length of the pressure ring	
$L_1$	[mm]	Distance of the pressure ring	
$L_2$	[mm]	Width of the locking device without screws	
$L_3$	[mm]	Width of the locking device with screws	
$Z$		Number of clamping screws	
$S$		Size of the clamping screws	
$M_A$		Tightening torque of the clamping screws	

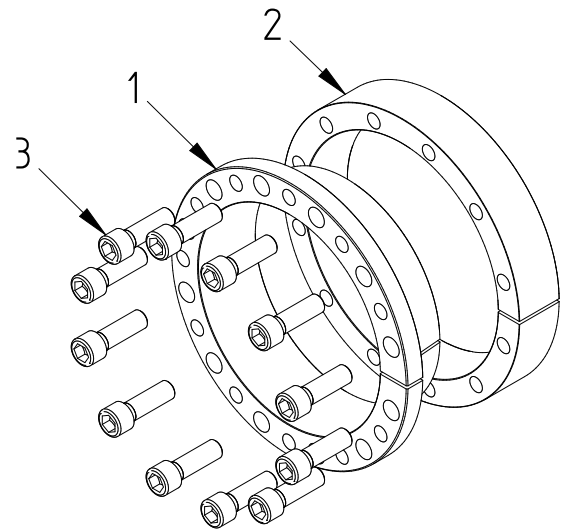

Pos.	Designation
1	Bush
2	Pressure ring
3	Screw

## Recommended tolerances & surfaces

Shaft	h8 / Rz10
Hub	H8 / Rz10

## Bending loads

Bending moment (share)	$M_B \text{ max} = 0,3 * M_t$
Bending angel	max. 5'

## More properties

- axial displacement during assembly
- good self-centering
- low self-locking

Ordering information: TAS 3003/d/D (for example: TAS 3003/150/200 ... further sizes on request)

<b>d</b> mm		<b>D</b> mm	<b>M<sub>t</sub></b> Nm	<b>F<sub>ax</sub></b> kN	<b>p<sub>w</sub></b> N/mm <sup>2</sup>	<b>p<sub>N</sub></b> N/mm <sup>2</sup>	<b>Z</b> Stk	<b>S</b>	<b>M<sub>A</sub></b> Nm	<b>L</b> mm	<b>L<sub>1</sub></b> mm	<b>L<sub>2</sub></b> mm	<b>L<sub>3</sub></b> mm	<b>Weight</b> kg
20	x	47	411	46	218	137	6	M6 x 020	14	17	22	28	34	0,26
22	x	47	453	46	198	137	6	M6 x 020	14	17	22	28	34	0,24
24	x	50	493	46	182	128	6	M6 x 020	14	17	22	28	34	0,27
25	x	50	514	46	175	128	6	M6 x 020	14	17	22	28	34	0,27
28	x	55	576	46	156	117	6	M6 x 020	14	17	22	28	34	0,32
30	x	55	617	46	145	117	6	M6 x 020	14	17	22	28	34	0,30
32	x	60	878	61	182	143	8	M6 x 020	14	17	22	28	34	0,37
35	x	60	959	61	166	143	8	M6 x 020	14	17	22	28	34	0,34
38	x	65	1041	61	153	132	8	M6 x 020	14	17	22	28	34	0,43
40	x	65	1096	61	145	132	8	M6 x 020	14	17	22	28	34	0,40
42	x	75	2208	117	221	186	8	M8 x 025	35	20	25	33	41	0,68
45	x	75	2365	117	207	186	8	M8 x 025	35	20	25	33	41	0,64
48	x	80	2523	117	185	174	8	M8 x 025	35	20	25	33,5	41,5	0,73
50	x	80	2628	117	177	174	8	M8 x 025	35	20	25	33,5	41,5	0,71
55	x	85	2891	117	161	164	8	M8 x 025	35	20	25	33,5	41,5	0,76
60	x	90	3154	117	148	155	8	M8 x 025	35	20	25	33,5	41,5	0,82
65	x	95	3416	117	136	147	8	M8 x 025	35	20	25	33,5	41,5	0,87
70	x	110	5995	190	176	172	8	M10 x 030	70	24	30	40	50	1,6
75	x	115	6423	190	164	165	8	M10 x 030	70	24	30	40	50	1,7
80	x	120	6851	190	154	158	8	M10 x 030	70	24	30	40	50	1,8
85	x	125	9099	238	181	189	10	M10 x 030	70	24	30	40	50	1,9
90	x	130	9635	238	171	182	10	M10 x 030	70	24	30	40	50	2,0
95	x	135	10170	238	162	175	10	M10 x 030	70	24	30	40	50	2,0
100	x	145	11902	264	158	168	8	M12 x 035	115	26	31	44	56	2,8
110	x	155	13091	264	144	157	8	M12 x 035	115	26	31	44	56	3,0
120	x	165	16067	298	148	166	9	M12 x 035	115	26	31	44	56	3,2
130	x	180	23207	397	152	155	12	M12 x 035	115	34	39	52	64	4,9
140	x	190	25513	405	138	150	9	M14 x 040	185	34	39	54	68	5,2
150	x	200	30372	450	143	158	10	M14 x 040	185	34	39	54	68	5,5
160	x	210	38876	540	161	181	12	M14 x 040	185	34	39	54	68	5,8
170	x	225	41306	540	126	130	12	M14 x 040	185	44	49	64	78	8,2
180	x	235	43736	540	119	125	12	M14 x 040	185	44	49	64	78	8,6
190	x	250	57708	675	141	147	15	M14 x 040	185	44	49	64	78	10,0
200	x	260	60745	675	134	141	15	M14 x 040	185	44	49	64	78	10,5

# 3006 plus

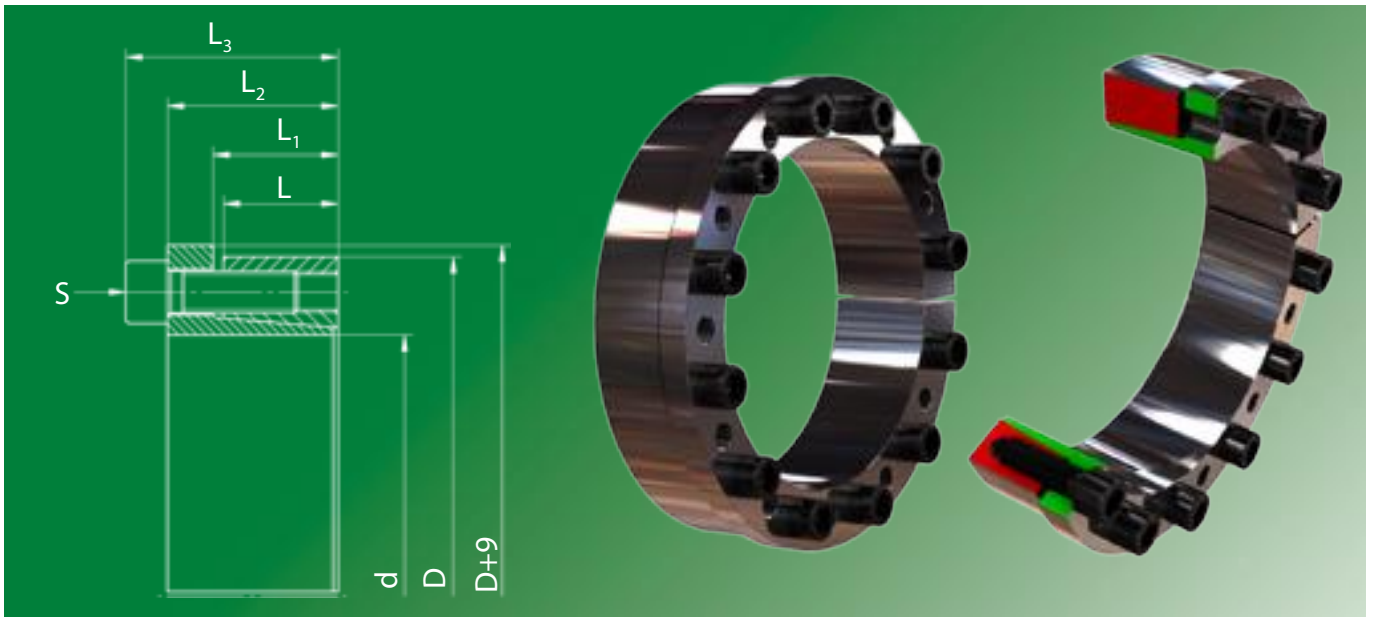

## Used symbols

$d$	[mm]	Shaft diameter	
$D$	[mm]	Hub inside diameter	
$M_t$	[Nm]	Max. transmittable torque	$F_{ax} = 0$
$F_{ax}$	[kN]	Max. transmittable axial force	$M_t = 0$
$p_w$	[N/mm <sup>2</sup> ]	Average pressure on the shaft	
$p_N$	[N/mm <sup>2</sup> ]	Average pressure on the hub	
$L$	[mm]	Length of the pressure ring	
$L_1$	[mm]	Distance of the pressure ring	
$L_2$	[mm]	Width of the locking device without screws	
$L_3$	[mm]	Width of the locking device with screws	
$Z$		Number of clamping screws	
$S$		Size of the clamping screws	
$M_A$		Tightening torque of the clamping screws	

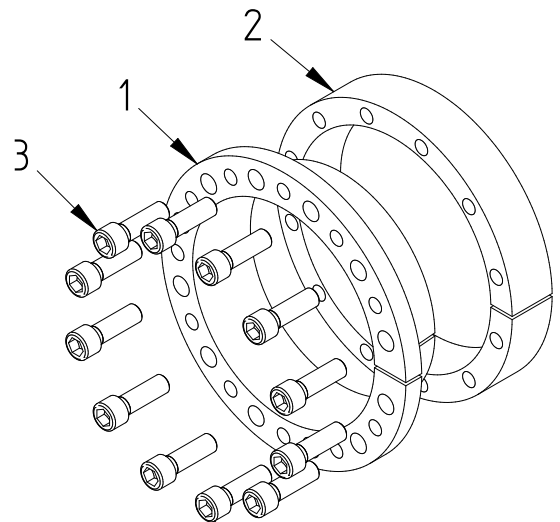

## Recommended tolerances & surfaces

Shaft	h8 / Rz10
Hub	H8 / Rz10

Pos.	Designation
1	Bush
2	Pressure ring
3	Screw

## Bending loads

Bending moment (share)	$M_B \max = 0,3 * M_t$
Bending angle	max. 5°

## More properties

- no axial displacement during assembly
- good self-centering
- low self-locking

Ordering information: TAS 3006 plus/d/D (for example: TAS 3006 plus/150/200 ... further sizes on request)

# 3006 plus

<b>d</b> mm		<b>D</b> mm	<b>M<sub>t</sub></b> Nm	<b>F<sub>ax</sub></b> kN	<b>P<sub>w</sub></b> N/mm <sup>2</sup>	<b>P<sub>N</sub></b> N/mm <sup>2</sup>	<b>Z</b> Stk	<b>S</b>	<b>M<sub>A</sub></b> Nm	<b>L</b> mm	<b>L<sub>1</sub></b> mm	<b>L<sub>2</sub></b> mm	<b>L<sub>3</sub></b> mm	<b>Weight</b> kg
20	x	47	260	27	208	88	5	M6 x 020	17	17	22	30	36	0,28
22	x	47	290	27	189	88	5	M6 x 020	17	17	22	30	36	0,27
24	x	50	310	27	173	83	5	M6 x 020	17	17	22	30	36	0,30
25	x	50	390	32	199	100	6	M6 x 020	17	17	22	30	36	0,29
28	x	55	440	32	178	91	6	M6 x 020	17	17	22	28	34	0,32
30	x	55	470	32	166	91	6	M6 x 020	17	17	22	30	36	0,33
32	x	60	680	43	208	111	8	M6 x 020	17	17	22	28	34	0,37
35	x	60	740	43	190	111	8	M6 x 020	17	17	22	30	36	0,37
38	x	65	800	43	175	102	8	M6 x 020	17	17	22	30	36	0,43
40	x	65	850	43	166	102	8	M6 x 020	17	17	22	30	36	0,40
45	x	75	1700	79	232	139	8	M8 x 025	41	20	25	34	42	0,64
50	x	80	1900	79	209	131	8	M8 x 025	41	20	25	34	42	0,70
55	x	85	2100	79	190	123	8	M8 x 025	41	20	25	34	42	0,75
60	x	90	2300	79	174	116	8	M8 x 025	41	20	25	34	42	0,80
65	x	95	2800	89	181	124	9	M8 x 025	41	20	25	34	42	0,86
70	x	110	4500	130	205	131	8	M10 x 030	83	24	29	41	51	1,60
75	x	115	4800	130	192	125	8	M10 x 030	83	24	30	42	52	1,69
80	x	120	5100	130	180	120	8	M10 x 030	83	24	30	41	51	1,73
85	x	125	6200	146	190	129	9	M10 x 030	83	24	30	41	51	1,81
90	x	130	6500	146	180	124	9	M10 x 030	83	24	29	41	51	1,95
95	x	135	7700	162	189	133	10	M10 x 030	83	24	29	41	51	2,04
100	x	145	10800	216	220	152	9	M12 x 035	145	26	32	46	58	2,72
110	x	155	11800	216	200	142	9	M12 x 035	145	26	32	46	58	2,94
120	x	165	12900	216	184	134	9	M12 x 035	145	26	31	46	58	3,24
130	x	180	18800	290	174	126	9	M14 x 040	230	34	40	57	71	4,87
140	x	190	20200	290	162	119	9	M14 x 040	230	34	40	57	71	5,19
150	x	200	24100	322	168	126	10	M14 x 040	230	34	40	57	71	5,50
160	x	210	30900	387	189	144	12	M14 x 040	230	34	40	57	71	5,82
170	x	225	32800	387	137	104	12	M14 x 040	230	44	50	67	81	8,17
180	x	235	34700	387	129	99	12	M14 x 040	230	44	50	67	81	8,58
190	x	250	50400	531	168	128	12	M16 x 050	355	44	50	67	83	9,93
200	x	260	53000	531	160	123	12	M16 x 050	355	44	50	67	83	10,38
220	x	285	58300	531	128	99	12	M16 x 050	355	50	56	75	91	13,96
240	x	305	79500	663	147	115	15	M16 x 050	355	50	56	75	91	15,07
260	x	325	103000	796	162	130	18	M16 x 050	355	50	56	76	93	16,41
280	x	355	120000	858	135	107	16	M18 x 060	485	60	66	87	105	23,78
300	x	375	144000	965	142	114	18	M18 x 060	485	60	66	87	105	25,28
320	x	405	198000	1241	139	110	18	M20 x 060	690	74	81	104	124	36,85
340	x	425	246000	1447	153	122	21	M20 x 060	690	74	81	104	124	38,89
360	x	455	278000	1548	133	105	18	M22 x 060	930	86	94	120	142	53,46
380	x	475	343000	1805	147	117	21	M22 x 060	930	86	94	120	142	56,09
400	x	495	361000	1805	139	112	21	M22 x 060	930	86	94	120	142	58,71

# 3006

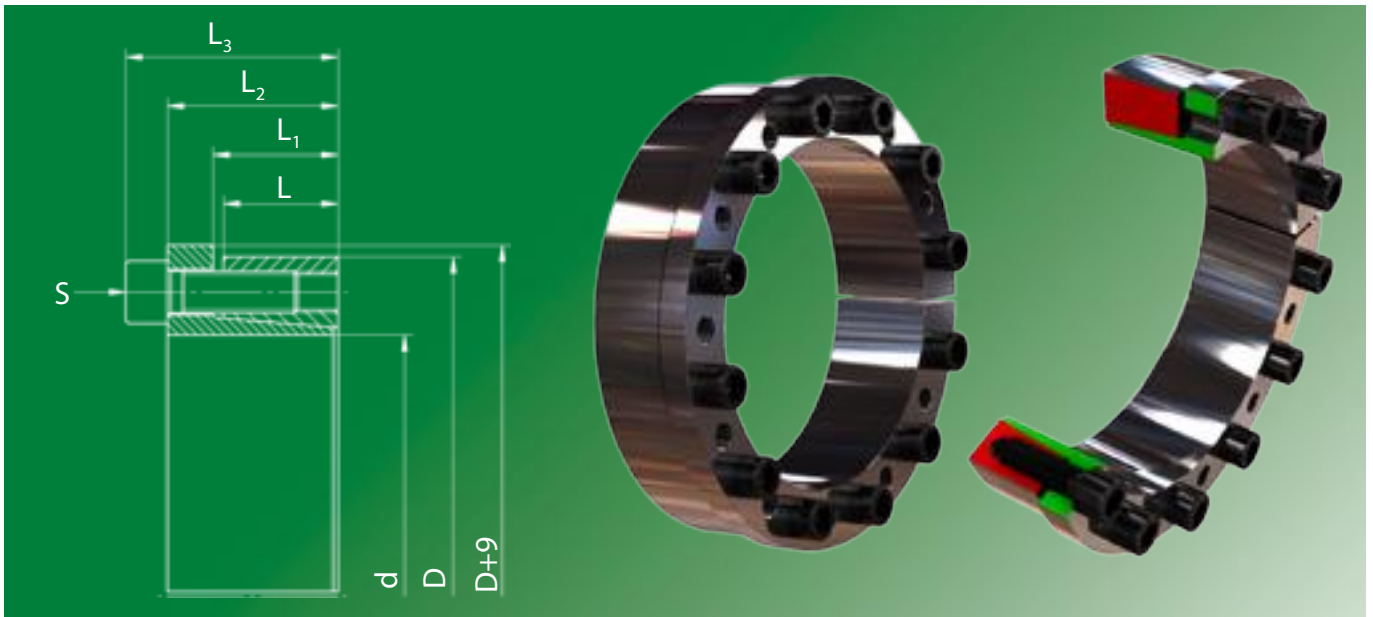

## Used symbols

$d$	[mm]	Shaft diameter	
$D$	[mm]	Hub inside diameter	
$M_t$	[Nm]	Max. transmittable torque	$F_{ax} = 0$
$F_{ax}$	[kN]	Max. transmittable axial force	$M_t = 0$
$p_w$	[N/mm <sup>2</sup> ]	Average pressure on the shaft	
$p_N$	[N/mm <sup>2</sup> ]	Average pressure on the hub	
$L$	[mm]	Length of the pressure ring	
$L_1$	[mm]	Distance of the pressure ring	
$L_2$	[mm]	Width of the locking device without screws	
$L_3$	[mm]	Width of the locking device with screws	
$Z$		Number of clamping screws	
$S$		Size of the clamping screws	
$M_A$		Tightening torque of the clamping screws	

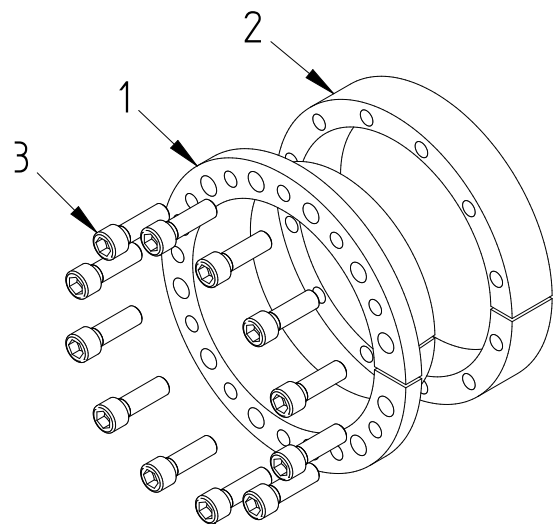

## Recommended tolerances & surfaces

Shaft	h8 / Rz10
Hub	H8 / Rz10

Pos.	Designation
1	Bush
2	Pressure ring
3	Screw

## Bending loads

Bending moment (share)	$M_B \max = 0,3 * M_t$
Bending angel	max. 5°

## More properties

- no axial displacement during assembly
- good self-centering
- low self-locking

Ordering information: TAS 3006/d/D (for example: TAS 3006/150/200 ... further sizes on request)

# 3006

<b>d</b> mm		<b>D</b> mm	<b>M<sub>t</sub></b> Nm	<b>F<sub>ax</sub></b> kN	<b>P<sub>w</sub></b> N/mm <sup>2</sup>	<b>P<sub>N</sub></b> N/mm <sup>2</sup>	<b>Z</b> Stk	<b>S</b>	<b>M<sub>A</sub></b> Nm	<b>L</b> mm	<b>L<sub>1</sub></b> mm	<b>L<sub>2</sub></b> mm	<b>L<sub>3</sub></b> mm	<b>Weight</b> kg
20	x	47	323	32,3	171	107	6	M6 x 020	17	17	22	28	34	0,28
22	x	47	355	32,3	156	107	6	M6 x 020	17	17	22	28	34	0,27
24	x	50	388	32,3	143	101	6	M6 x 020	17	17	22	28	34	0,30
25	x	50	404	32,3	137	101	6	M6 x 020	17	17	22	28	34	0,29
28	x	55	452	32,3	122	92	6	M6 x 020	17	17	22	28	34	0,32
30	x	55	485	32,3	114	92	6	M6 x 020	17	17	22	28	34	0,33
32	x	60	689	42,8	143	112	8	M6 x 020	17	17	22	28	34	0,37
35	x	60	753	42,8	131	112	8	M6 x 020	17	17	22	28	34	0,37
38	x	65	818	42,8	120	103	8	M6 x 020	17	17	22	28	34	0,43
40	x	65	862	42,8	114	103	8	M6 x 020	17	17	22	28	34	0,40
42	x	75	1673	79,8	168	141	8	M8 x 025	41	20	25	33	41	0,69
45	x	75	1793	79,8	157	141	8	M8 x 025	41	20	25	33	41	0,64
48	x	80	1912	79,8	140	132	8	M8 x 025	41	20	24	33,5	41,5	0,74
50	x	80	1991	79,8	134	132	8	M8 x 025	41	20	24	33,5	41,5	0,70
55	x	85	2191	79,8	122	124	8	M8 x 025	41	20	24	33,5	41,5	0,75
60	x	90	2390	79,8	112	117	8	M8 x 025	41	20	24	33,5	41,5	0,80
65	x	95	2589	79,8	103	111	8	M8 x 025	41	20	24	33,5	41,5	0,86
70	x	110	4599	131,1	135	132	8	M10 x 030	83	24	30	40	50	1,60
75	x	115	4928	131,1	126	126	8	M10 x 030	83	24	30	40	50	1,69
80	x	120	5255	131,1	118	121	8	M10 x 030	83	24	30	40	50	1,73
85	x	125	6981	164,4	138	145	10	M10 x 030	83	24	30	40	50	1,81
90	x	130	7391	164,4	131	140	10	M10 x 030	83	24	30	40	50	1,95
95	x	135	7801	164,4	124	135	10	M10 x 030	83	24	30	40	50	2,04
100	x	145	9708	193,8	129	137	8	M12 x 035	145	26	32	44	56	2,72
110	x	155	10679	193,8	117	128	8	M12 x 035	145	26	32	44	56	2,94
120	x	165	13106	218,5	121	135	9	M12 x 035	145	26	32	44	56	3,24
130	x	180	18932	291,7	124	126	12	M12 x 035	145	34	40	54	64	4,87
140	x	190	20521	293,6	111	120	9	M14 x 040	230	34	40	54	68	5,19
150	x	200	24429	325,9	115	127	10	M14 x 040	230	34	40	54	68	5,50
160	x	210	31269	390,5	130	145	12	M14 x 040	230	34	40	54	68	5,82
170	x	225	33223	390,5	102	105	12	M14 x 040	230	44	50	64	78	8,17
180	x	235	35179	390,5	96	100	12	M14 x 040	230	44	50	64	78	8,58
190	x	250	46416	488,3	114	118	15	M14 x 040	230	44	50	64	78	9,93
200	x	260	48859	488,3	108	113	15	M14 x 040	230	44	50	64	78	10,38

# 3012

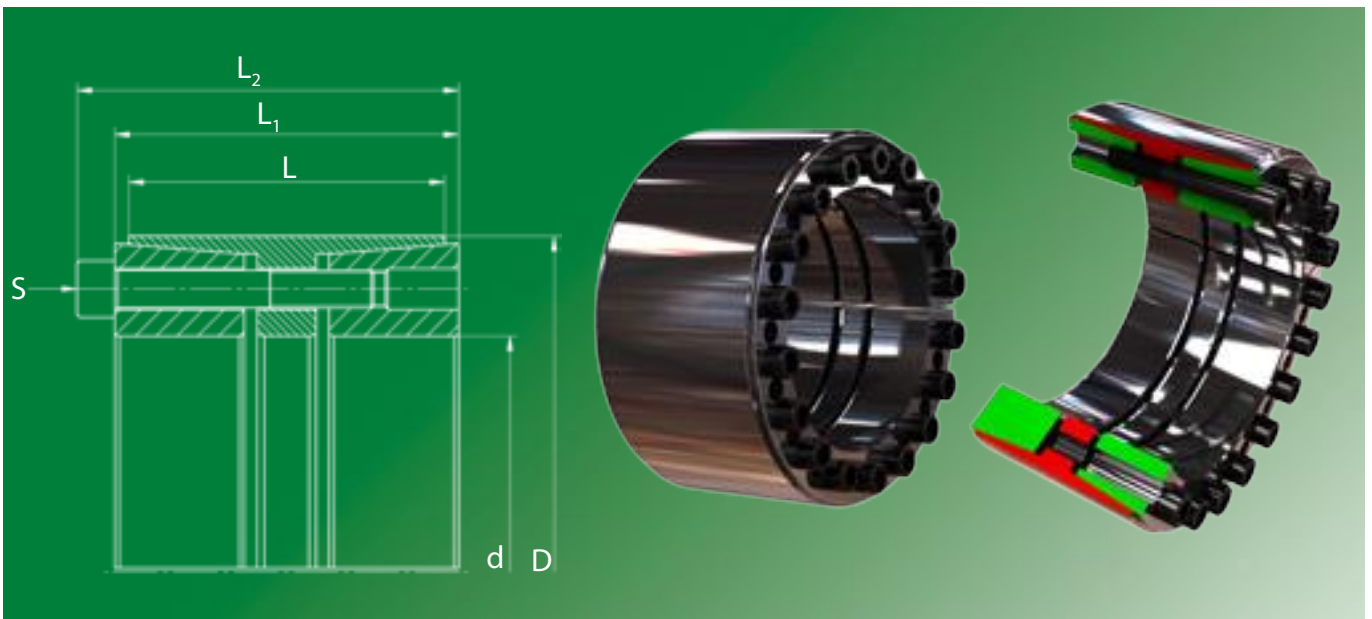

## Used symbols

$d$	[mm]	Shaft diameter	
$D$	[mm]	Hub inside diameter	
$M_t$	[Nm]	Max. transmittable torque	$F_{ax} = 0$
$F_{ax}$	[kN]	Max. transmittable axial force	$M_t = 0$
$p_w$	[N/mm <sup>2</sup> ]	Average pressure on the shaft	
$p_N$	[N/mm <sup>2</sup> ]	Average pressure on the hub	
$L$	[mm]	Length of the bush	
$L_1$	[mm]	Width of the locking device without screws	
$L_2$	[mm]	Width of the locking device with screws	
$Z$		Number of clamping screws	
$S$		Size of the clamping screws	
$M_A$		Tightening torque of the clamping screws	

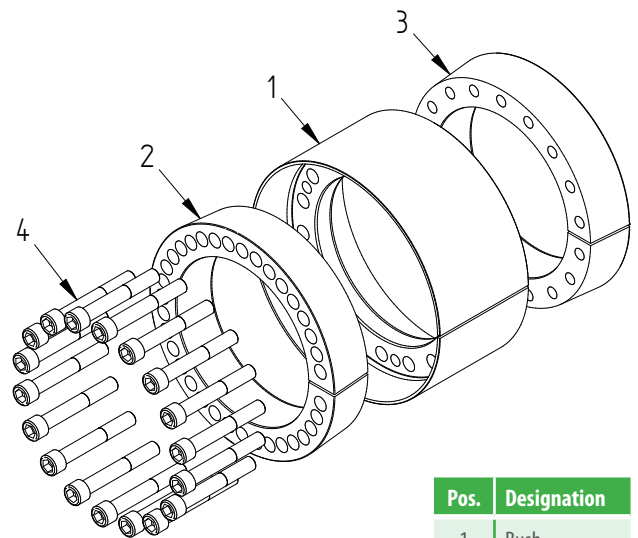

Pos.	Designation
1	Bush
2	Pressure ring 1
3	Pressure ring 2
4	Screw

## Recommended tolerances & surfaces

Shaft	h8 / Rz10
Hub	H8 / Rz10

## Bending loads

Bending moment (share)	$M_B \max = 0,4 * M_t$
Bending angle	max. 5°

## More properties

- low axial displacement during assembly
- very good self-centering
- high self-locking

Ordering information: TAS 3012/d/D (for example: TAS 3012/150/200 ... further sizes on request)

<b>d</b> mm		<b>D</b> mm	<b>M<sub>t</sub></b> Nm	<b>F<sub>ax</sub></b> kN	<b>P<sub>w</sub></b> N/mm <sup>2</sup>	<b>P<sub>N</sub></b> N/mm <sup>2</sup>	<b>Z</b> Stk	<b>S</b>	<b>M<sub>A</sub></b> Nm	<b>L</b> mm	<b>L<sub>1</sub></b> mm	<b>L<sub>2</sub></b> mm	<b>Weight</b> kg
25	x	50	660	53	153	63	5	M6 x 045	17	45	53	59	0,5
30	x	55	950	64	153	68	6	M6 x 045	17	45	53	59	0,6
35	x	60	1300	75	153	73	7	M6 x 045	17	45	53	59	0,7
38	x	65	1600	85	161	77	8	M6 x 045	17	45	53	59	0,8
40	x	65	1700	85	153	77	8	M6 x 045	17	45	53	59	0,7
45	x	75	3100	138	239	111	7	M8 x 050	41	44	54	62	1,0
50	x	80	3900	158	190	93	8	M8 x 050	41	56	62	70	1,3
55	x	85	4800	177	194	99	9	M8 x 050	41	56	62	70	1,5
60	x	90	5900	197	198	104	10	M8 x 050	41	56	62	70	1,6
65	x	95	6400	197	183	98	10	M8 x 050	41	56	62	70	1,7
70	x	110	11300	325	220	112	10	M10 x 060	83	70	78	88	3,1
80	x	120	14200	357	212	113	11	M10 x 060	83	70	78	88	3,5
90	x	130	17500	390	205	114	12	M10 x 060	83	70	78	88	3,8
100	x	145	26400	528	200	107	11	M12 x 080	145	90	100	112	6,1
110	x	155	31600	576	198	110	12	M12 x 080	145	90	100	112	6,6
120	x	165	40300	672	212	120	14	M12 x 080	145	90	100	112	7,1
130	x	180	50200	773	188	110	12	M14 x 090	230	104	116	130	9,9
140	x	190	63100	902	203	121	14	M14 x 090	230	104	116	130	10,6
150	x	200	72400	966	203	123	15	M14 x 090	230	104	116	130	11,2
160	x	210	82400	1031	203	125	16	M14 x 090	230	104	118	132	11,9
170	x	225	105000	1238	176	109	14	M16 x 110	355	134	146	162	17,9
180	x	235	119000	1327	178	112	15	M16 x 110	355	134	146	162	18,9
190	x	250	134000	1415	180	112	16	M16 x 110	355	134	146	162	21,8
200	x	260	141000	1415	171	108	16	M16 x 110	355	134	146	162	22,8
220	x	285	175000	1592	174	111	18	M16 x 110	355	134	146	162	27,1
240	x	305	212000	1769	178	115	20	M16 x 110	355	134	146	162	29,3
260	x	325	229000	1769	164	108	20	M16 x 110	355	134	146	162	31,4
280	x	355	347000	2481	178	112	18	M20 x 130	690	165	177	197	48,4
300	x	375	413000	2757	185	118	20	M20 x 130	690	165	177	197	51,5
320	x	405	463000	2895	182	115	21	M20 x 130	690	165	177	197	62,7
340	x	425	515000	3033	174	115	22	M20 x 130	690	165	177	197	66,1
360	x	455	649000	3611	174	111	21	M22 x 150	930	190	202	224	90,7
380	x	475	718000	3783	173	111	22	M22 x 150	930	190	202	224	95,1
400	x	495	825000	4127	179	116	24	M22 x 150	930	190	202	224	100
420	x	515	866000	4127	170	112	24	M22 x 150	930	190	202	224	104
440	x	535	907000	4127	163	108	24	M22 x 150	930	190	202	224	109
460	x	555	949000	4127	156	104	24	M22 x 150	930	190	202	224	113
480	x	575	1155000	4814	174	117	28	M22 x 150	930	190	202	224	117
500	x	595	1203000	4814	167	113	28	M22 x 150	930	190	202	224	122
520	x	615	1341000	5158	172	117	30	M22 x 150	930	190	202	224	126
540	x	635	1437000	5325	171	117	30	M22 x 150	930	190	202	224	131
560	x	655	1590000	5680	176	121	32	M22 x 150	930	190	202	224	135
580	x	675	1698000	5857	175	121	33	M22 x 150	930	190	202	224	140
600	x	695	1757000	5857	169	118	33	M22 x 150	930	190	202	224	144
620	x	715	1870000	6035	169	118	34	M22 x 150	930	190	202	224	149

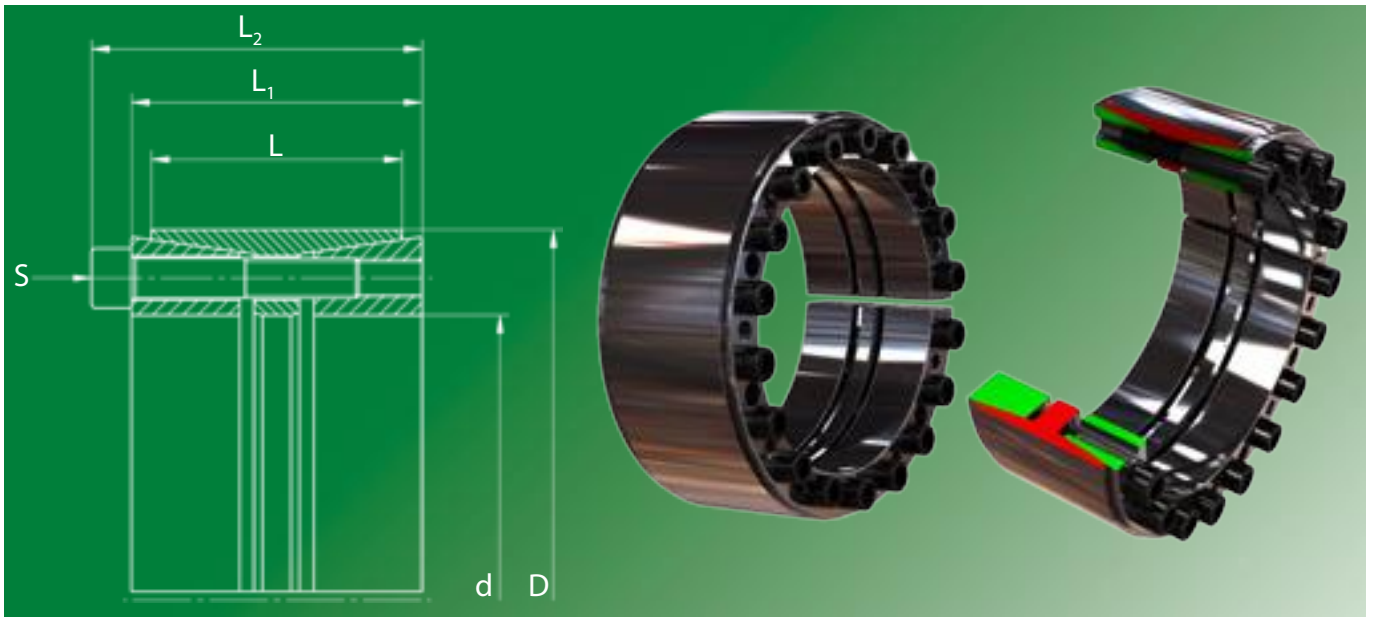

## Used symbols

$d$	[mm]	Shaft diameter	
$D$	[mm]	Hub inside diameter	
$M_t$	[Nm]	Max. transmittable torque	$F_{ax} = 0$
$F_{ax}$	[kN]	Max. transmittable axial force	$M_t = 0$
$p_w$	[N/mm <sup>2</sup> ]	Average pressure on the shaft	
$p_N$	[N/mm <sup>2</sup> ]	Average pressure on the hub	
$L$	[mm]	Length of the bush	
$L_1$	[mm]	Width of the locking device without screws	
$L_2$	[mm]	Width of the locking device with screws	
$Z$		Number of clamping screws	
$S$		Size of the clamping screws	
$M_A$		Tightening torque of the clamping screws	

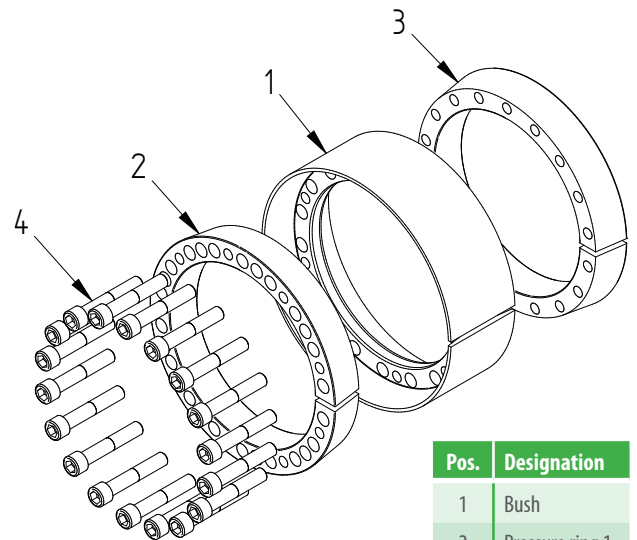

Pos.	Designation
1	Bush
2	Pressure ring 1
3	Pressure ring 2
4	Screw

## Recommended tolerances & surfaces

Shaft	h8 / Rz10
Hub	H8 / Rz10

## Bending loads

Bending moment (share)	$M_B \text{ max} = 0,4 * M_t$
Bending angel	max. 5°

## More properties

- low axial displacement during assembly
- good self-centering
- low self-locking

Ordering information: TAS RB/d/D (for example: TAS RB/150/200 ... further sizes on request)

<b>d</b> mm		<b>D</b> mm	<b>M<sub>t</sub></b> Nm	<b>F<sub>ax</sub></b> kN	<b>p<sub>w</sub></b> N/mm <sup>2</sup>	<b>p<sub>N</sub></b> N/mm <sup>2</sup>	<b>Z</b> Stk	<b>S</b>	<b>M<sub>A</sub></b> Nm	<b>L</b> mm	<b>L<sub>1</sub></b> mm	<b>L<sub>2</sub></b> mm	<b>Weight</b> kg
100	x	145	7800	157	80	46	7	M10x060	83	62	74	84	4,2
110	x	155	9800	180	83	50	8	M10x060	83	62	74	84	4,6
120	x	165	12100	202	83	51	9	M10x060	83	64	76	86	5,1
130	x	180	14600	225	85	52	10	M10x060	83	64	76	86	6,1
140	x	190	17300	247	84	52	11	M10x060	83	66	78	88	6,7
150	x	200	18500	247	73	53	11	M10x070	83	62	84	94	6,7
160	x	210	23900	299	75	48	9	M12x075	145	78	92	104	8,9
170	x	225	28200	332	79	50	10	M12x075	145	78	92	104	10,4
180	x	235	29800	332	79	50	10	M12x070	145	75	86	100	10,6
190	x	250	38100	401	67	50	9	M14x080	230	85	112	126	13,8
200	x	260	44500	446	70	54	10	M14x090	230	85	112	126	14,5
220	x	285	53900	490	74	54	11	M14x090	230	85	112	126	17,2
240	x	305	66000	551	76	56	9	M16x090	355	85	112	128	18,6
260	x	325	87400	673	75	57	11	M16x100	355	97	124	140	22,7
280	x	355	111000	795	72	55	13	M16x090	355	108	136	152	31,7
300	x	375	119000	795	73	52	13	M16x090	355	108	127	143	33,7
320	x	405	138000	865	65	47	15	M16x090	355	120	142	142	45,6
340	x	425	142000	841	60	44	15	M16x090	355	120	142	158	48,1
360	x	455	195000	1088	67	49	16	M18x130	485	130	160	178	62,1
380	x	475	235000	1240	67	48	13	M20x130	690	145	172	192	72,6
400	x	495	305000	1526	78	56	16	M20x130	690	145	172	192	76,0
420	x	515	320000	1526	69	54	16	M20x130	690	145	180	190	79,4
440	x	545	377000	1717	74	52	18	M20x130	690	160	180	200	102,0
460	x	565	394000	1717	71	56	18	M20x130	690	145	180	200	96,2
480	x	585	457000	1907	75	54	20	M20x130	690	160	180	200	110,3
500	x	605	476000	1907	72	60	20	M20x130	690	140	180	200	100,1
520	x	630	556000	2141	73	50	18	M22x140	930	180	202	224	140,4
540	x	650	610000	2260	74	51	19	M22x140	930	180	202	224	145,3
560	x	670	666000	2379	75	52	20	M22x140	930	180	202	224	150,2
580	x	690	632000	2180	66	47	20	M22x140	930	180	208	208	155,0
600	x	710	653000	2180	64	45	20	M22x140	930	180	208	230	159,9
620	x	730	585000	1888	78	62	21	M20x090	930	110	140	140	100,7

# 3015

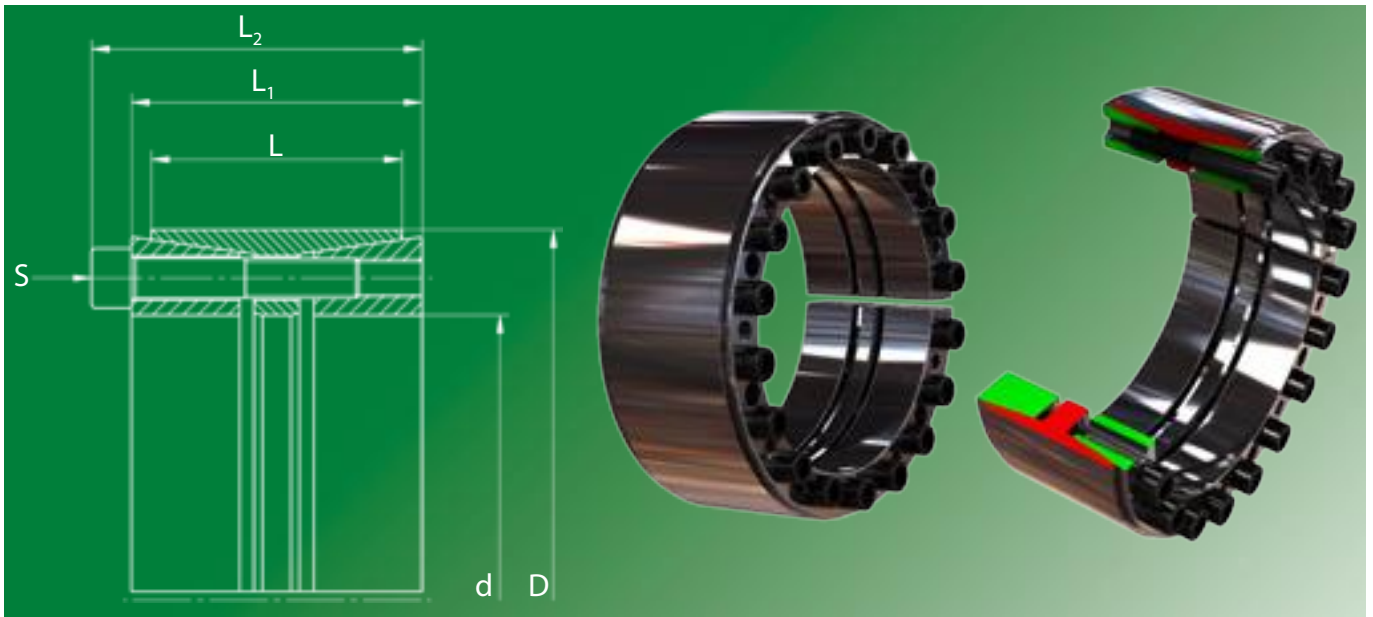

## Used symbols

$d$	[mm]	Shaft diameter	
$D$	[mm]	Hub inside diameter	
$M_t$	[Nm]	Max. transmittable torque	$F_{ax} = 0$
$F_{ax}$	[kN]	Max. transmittable axial force	$M_t = 0$
$p_w$	[N/mm <sup>2</sup> ]	Average pressure on the shaft	
$p_n$	[N/mm <sup>2</sup> ]	Average pressure on the hub	
$L$	[mm]	Length of the bush	
$L_1$	[mm]	Width of the locking device without screws	
$L_2$	[mm]	Width of the locking device with screws	
$Z$		Number of clamping screws	
$S$		Size of the clamping screws	
$M_A$		Tightening torque of the clamping screws	

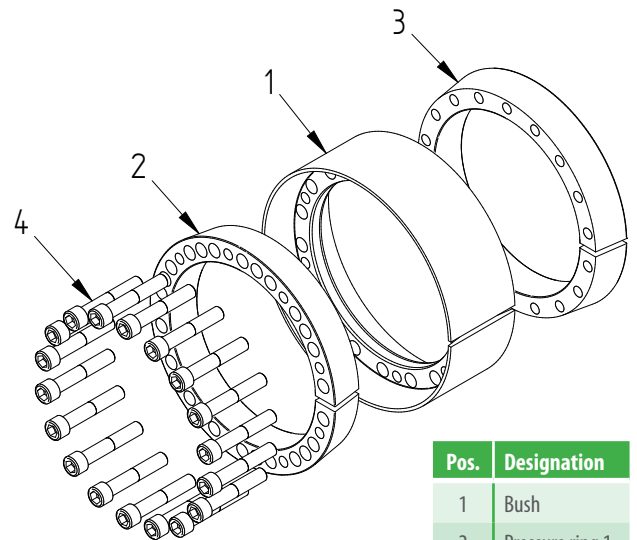

Pos.	Designation
1	Bush
2	Pressure ring 1
3	Pressure ring 2
4	Screw

## Recommended tolerances & surfaces

Shaft	h8 / Rz10
Hub	H8 / Rz10

## Bending loads

Bending moment (share)	$M_B \text{ max} = 0,3 * M_t$
Bending angle	max. 5°

## More properties

- low axial displacement during assembly
- good self-centering
- low self-locking

Ordering information: TAS 3015/d/D (for example: TAS 3015/150/200 ... further sizes on request)

<b>d</b> mm		<b>D</b> mm	<b>M<sub>t</sub></b> Nm	<b>F<sub>ax</sub></b> kN	<b>P<sub>w</sub></b> N/mm <sup>2</sup>	<b>P<sub>N</sub></b> N/mm <sup>2</sup>	<b>Z</b> Stk	<b>S</b>	<b>M<sub>A</sub></b> Nm	<b>L</b> mm	<b>L<sub>1</sub></b> mm	<b>L<sub>2</sub></b> mm	<b>Weight</b> kg
70	x	110	6900	197	187	95	8	M10 x 055	83	50	60	70	2,2
80	x	120	9800	247	204	109	10	M10 x 055	83	50	60	70	2,5
90	x	130	12200	271	200	111	11	M10 x 055	83	50	60	70	2,7
100	x	145	18200	364	201	111	10	M12 x 060	145	60	70	82	4,1
110	x	155	20000	364	183	104	10	M12 x 060	145	60	70	82	4,4
120	x	165	24000	401	185	107	11	M12 x 060	145	60	70	82	4,7
130	x	180	33100	510	193	116	14	M12 x 065	145	65	79	91	6,2
140	x	190	38200	547	192	117	15	M12 x 065	145	65	79	91	6,6
150	x	200	40900	547	179	112	15	M12 x 065	145	65	79	91	7,0
160	x	210	46600	583	179	113	16	M12 x 065	145	65	79	91	7,4
170	x	225	62300	734	179	111	15	M14 x 075	230	78	92	106	10,4
180	x	235	66000	734	169	106	15	M14 x 075	230	78	92	106	11,0
190	x	250	74300	782	144	94	16	M14 x 080	230	88	102	116	14,3
200	x	260	97100	972	170	113	18	M14 x 080	230	88	102	116	15,0
220	x	285	110000	1007	148	98	15	M16 x 090	355	96	108	124	19,4
240	x	305	161000	1342	181	122	20	M16 x 090	355	96	108	124	21,0
260	x	325	174000	1342	167	114	20	M16 x 090	355	96	108	124	22,5
280	x	355	219000	1569	196	122	15	M20 x 100	690	96	110	130	28,2
300	x	375	251000	1674	195	123	16	M20 x 100	690	96	110	130	30,0
320	x	405	334000	2092	181	111	20	M20 x 110	690	124	136	156	47,1
340	x	425	355000	2092	170	105	20	M20 x 110	690	124	136	156	49,7
360	x	455	469000	2610	160	109	20	M22 x 130	930	140	157	179	66,8
380	x	475	495000	2610	152	104	20	M22 x 130	930	140	157	179	70,1
400	x	495	574000	2871	159	110	22	M22 x 130	930	140	157	179	73,4
420	x	515	657000	3132	165	115	24	M22 x 130	930	140	157	179	76,7
440	x	535	689000	3132	157	111	24	M22 x 130	930	140	157	179	79,9
460	x	555	720000	3132	151	107	24	M22 x 130	930	140	157	179	83,2
480	x	575	782000	3262	150	108	25	M22 x 130	930	140	157	179	86,5
500	x	595	815000	3262	144	104	25	M22 x 130	930	140	157	179	89,8
520	x	615	950000	3654	155	113	28	M22 x 130	930	140	157	179	93,1
540	x	635	986000	3654	150	109	28	M22 x 130	930	140	157	179	96,3
560	x	655	1096000	3915	155	113	30	M22 x 130	930	140	157	179	100
580	x	675	1135000	3915	149	110	30	M22 x 130	930	140	157	179	103
600	x	695	1174000	3915	144	107	30	M22 x 130	930	140	157	179	106

# 3015.1

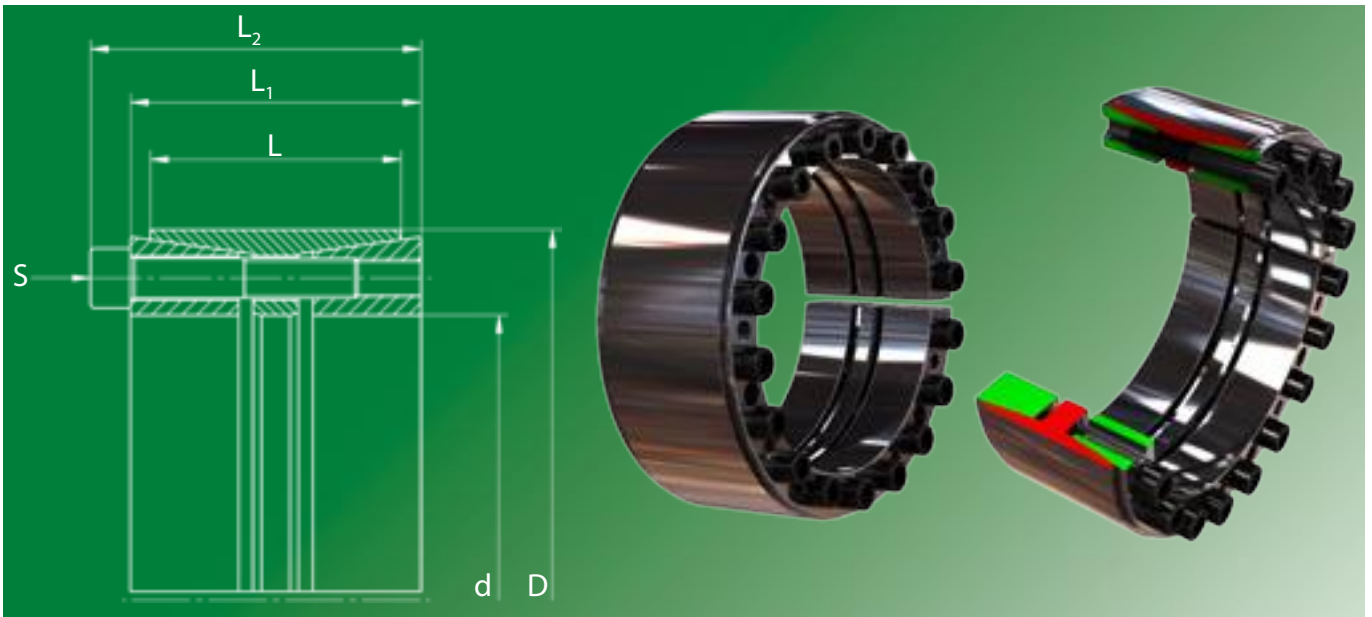

## Used symbols

$d$	[mm]	Shaft diameter	
$D$	[mm]	Hub inside diameter	
$M_t$	[Nm]	Max. transmittable torque	$F_{ax} = 0$
$F_{ax}$	[kN]	Max. transmittable axial force	$M_t = 0$
$p_w$	[N/mm <sup>2</sup> ]	Average pressure on the shaft	
$p_N$	[N/mm <sup>2</sup> ]	Average pressure on the hub	
$L$	[mm]	Length of the bush	
$L_1$	[mm]	Width of the locking device without screws	
$L_2$	[mm]	Width of the locking device with screws	
$Z$		Number of clamping screws	
$S$		Size of the clamping screws	
$M_A$		Tightening torque of the clamping screws	

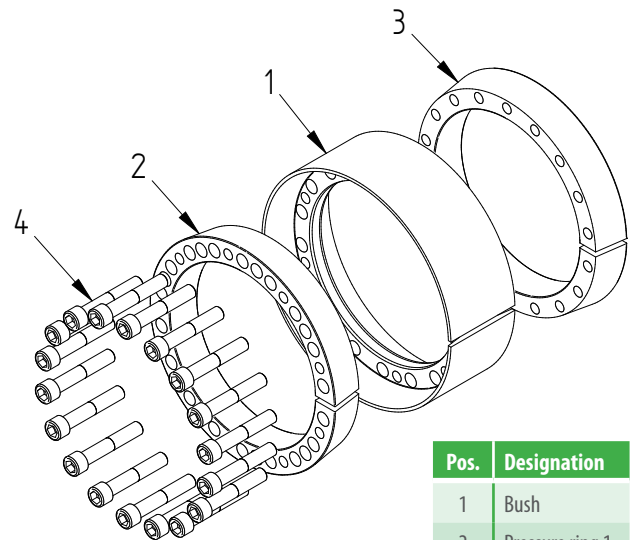

Pos.	Designation
1	Bush
2	Pressure ring 1
3	Pressure ring 2
4	Screw

## Recommended tolerances & surfaces

Shaft	h8 / Rz10
Hub	H8 / Rz10

## Bending loads

Bending moment (share)	$M_B \max = 0,4 * M_t$
Bending angel	max. 5°

## More properties

- low axial displacement during assembly
- good self-centering
- low self-locking

Ordering information: TAS 3015.1/d/D (for example: TAS 3015.1/150/200 ... further sizes on request)

# 3015.1

<b>d</b> mm		<b>D</b> mm	<b>M<sub>t</sub></b> Nm	<b>F<sub>ax</sub></b> kN	<b>P<sub>w</sub></b> N/mm <sup>2</sup>	<b>P<sub>N</sub></b> N/mm <sup>2</sup>	<b>Z</b> Stk	<b>S</b>	<b>M<sub>A</sub></b> Nm	<b>L</b> mm	<b>L<sub>1</sub></b> mm	<b>L<sub>2</sub></b> mm	<b>Weight</b> kg
70	x	110	4000	116	110	56	8	M10 x 055	49	50	60	70	2,2
80	x	120	5800	146	121	64	10	M10 x 055	49	50	60	70	2,5
90	x	130	7200	160	118	65	11	M10 x 055	49	50	60	70	2,7
100	x	145	8600	173	96	53	10	M12 x 060	69	60	70	82	4,1
110	x	155	9500	173	87	49	10	M12 x 060	69	60	70	82	4,4
120	x	165	11400	191	88	51	11	M12 x 060	69	60	70	82	4,7
130	x	180	15700	243	92	55	14	M12 x 065	69	65	79	91	6,2
140	x	190	18200	260	91	56	15	M12 x 065	69	65	79	91	6,6
150	x	200	19500	260	85	53	15	M12 x 065	69	65	79	91	7,0
160	x	210	22100	277	85	54	16	M12 x 065	69	65	79	91	7,4
170	x	225	29200	344	84	52	15	M14 x 075	108	78	92	106	10,4
180	x	235	30900	344	79	50	15	M14 x 075	108	78	92	106	11,0
190	x	250	34900	367	67	44	16	M14 x 080	108	88	102	116	14,3
200	x	260	45600	456	80	53	18	M14 x 080	108	88	102	116	15,0
220	x	285	52400	476	70	46	15	M16 x 090	168	96	108	124	19,4
240	x	305	76200	635	86	58	20	M16 x 090	168	96	108	124	21,0
260	x	325	82500	635	79	54	20	M16 x 090	168	96	108	124	22,5
280	x	355	117000	839	105	65	15	M20 x 100	369	96	110	130	28,2
300	x	375	134000	895	104	66	16	M20 x 100	369	96	110	130	30,0
320	x	405	179000	1119	97	59	20	M20 x 110	369	124	136	156	47,1
340	x	425	190000	1119	91	56	20	M20 x 110	369	124	136	156	49,7
360	x	455	250000	1389	85	58	20	M22 x 130	495	140	157	179	66,8
380	x	475	263000	1389	81	55	20	M22 x 130	495	140	157	179	70,1
400	x	495	305000	1528	84	58	22	M22 x 130	495	140	157	179	73,4
420	x	515	350000	1667	88	61	24	M22 x 130	495	140	157	179	76,7
440	x	535	366000	1667	84	59	24	M22 x 130	550	140	157	179	79,9
460	x	555	383000	1667	80	57	24	M22 x 130	550	140	157	179	83,2
480	x	575	416000	1736	80	57	25	M22 x 130	550	140	157	179	86,5
500	x	595	434000	1736	77	55	25	M22 x 130	550	140	157	179	89,8
520	x	615	505000	1945	83	60	28	M22 x 130	550	140	157	179	93,1
540	x	635	525000	1945	80	58	28	M22 x 130	550	140	157	179	96,3
560	x	655	583000	2084	82	60	30	M22 x 130	550	140	157	179	99,6
580	x	675	604000	2084	79	58	30	M22 x 130	550	140	157	179	103
600	x	695	625000	2084	77	57	30	M22 x 130	550	140	157	179	106

# 3015 DK

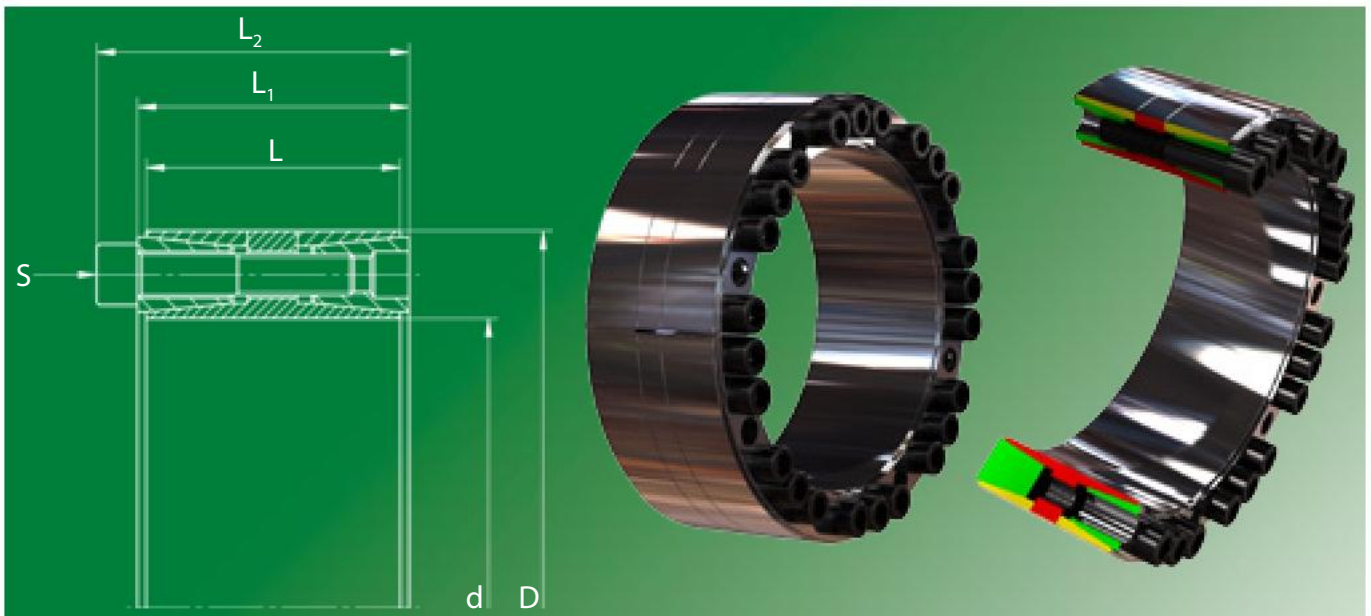

## Used symbols

$d$	[mm]	Shaft diameter	
$D$	[mm]	Hub inside diameter	
$M_t$	[Nm]	Max. transmittable torque	$F_{ax} = 0$
$F_{ax}$	[kN]	Max. transmittable axial force	$M_t = 0$
$p_w$	[N/mm <sup>2</sup> ]	Average pressure on the shaft	
$p_n$	[N/mm <sup>2</sup> ]	Average pressure on the hub	
$L$	[mm]	Length of the bush	
$L_1$	[mm]	Width of the locking device without screws	
$L_2$	[mm]	Width of the locking device with screws	
$Z$		Number of clamping screws	
$S$		Size of the clamping screws	
$M_A$		Tightening torque of the clamping screws	

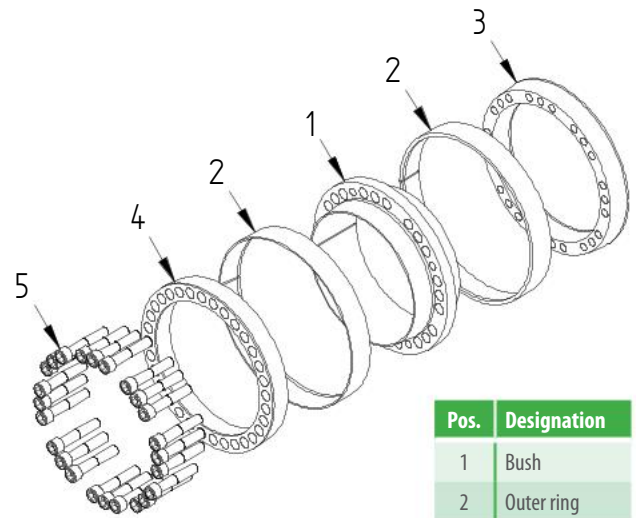

Pos.	Designation
1	Bush
2	Outer ring
3	Pressure ring 1
4	Pressure ring 2
5	Screw

## Recommended tolerances & surfaces

Shaft	h8 / Rz10
Hub	H8 / Rz10

## Bending loads

Bending moment (share)	$M_B \text{ max} = 0,25 * M_t$
Bending angle	max. 5°

## More properties

- no axial displacement during assembly
- good self-centering
- low self-locking

Ordering information: TAS 3015 DK/d/D (for example: TAS 3015 DK/150/200 ... further sizes on request)

# 3015 DK

<b>d</b> mm		<b>D</b> mm	<b>M<sub>t</sub></b> Nm	<b>F<sub>ax</sub></b> kN	<b>P<sub>w</sub></b> N/mm <sup>2</sup>	<b>P<sub>N</sub></b> N/mm <sup>2</sup>	<b>Z</b> Stk	<b>S</b>	<b>M<sub>A</sub></b> Nm	<b>L</b> mm	<b>L<sub>1</sub></b> mm	<b>L<sub>2</sub></b> mm	<b>Weight</b> kg
100	x	145	15000	300	217	150	10	M12 x 055	145	60	65	77	4,1
110	x	155	16500	300	197	140	10	M12 x 055	145	60	65	77	4,4
120	x	165	21600	360	217	158	12	M12 x 055	145	60	65	77	4,8
130	x	180	29200	450	212	153	15	M12 x 060	145	68	74	86	6,5
140	x	190	37800	540	236	174	18	M12 x 060	145	68	74	86	7,0
150	x	200	40500	540	220	165	18	M12 x 060	145	68	74	86	7,4
160	x	210	48000	600	230	175	20	M12 x 060	145	68	74	86	7,8
170	x	225	61600	725	234	177	18	M14 x 065	230	75	81	95	10,0
180	x	235	65200	725	221	169	18	M14 x 065	230	75	81	95	10,6
190	x	250	76500	805	198	151	20	M14 x 075	230	88	94	108	14,3
200	x	260	96600	966	226	174	24	M14 x 075	230	88	94	108	15,0
220	x	285	109400	995	203	156	18	M16 x 090	355	98	104	120	19,8
240	x	305	159200	1326	248	195	24	M16 x 090	355	98	104	120	21,4
260	x	325	179600	1382	238	191	25	M16 x 090	355	98	104	120	23,0
280	x	355	225200	1608	208	164	24	M18 x 110	485	120	126	144	35,2
300	x	375	251300	1675	202	162	25	M18 x 110	485	120	126	144	37,4
320	x	405	344600	2153	208	164	25	M20 x 120	690	135	142	162	51,3
340	x	425	366100	2153	196	157	25	M20 x 120	690	135	142	162	54,1
360	x	455	483500	2686	198	157	25	M22 x 130	930	158	165	187	75,4
380	x	475	510400	2686	188	150	25	M22 x 130	930	158	165	187	79,0
400	x	495	537200	2686	178	144	25	M22 x 130	930	158	165	187	82,8
420	x	515	676900	3223	204	166	30	M22 x 130	930	158	165	187	86,5
440	x	545	829200	3769	207	167	30	M24 x 150	1200	172	180	204	110
460	x	565	866900	3769	198	161	30	M24 x 150	1200	172	180	204	114
480	x	585	964600	4020	202	166	32	M24 x 150	1200	172	180	204	119
500	x	605	100500	4020	194	160	32	M24 x 150	1200	172	180	204	123
520	x	630	1162900	4473	183	151	30	M27 x 160	1600	190	200	227	148
540	x	650	1207600	4473	176	146	30	M27 x 160	1600	190	200	227	154
560	x	670	1252400	4473	169	142	30	M27 x 160	1600	190	200	227	160
580	x	690	1297100	4473	164	138	30	M27 x 160	1600	190	200	227	165
600	x	710	1431300	4771	169	143	32	M27 x 160	1600	190	200	227	170
620	x	730	1478000	4771	163	139	32	M27 x 160	1600	190	200	227	175
640	x	750	1526000	4771	158	135	32	M27 x 160	1600	190	200	227	180

# 3015.1 DK

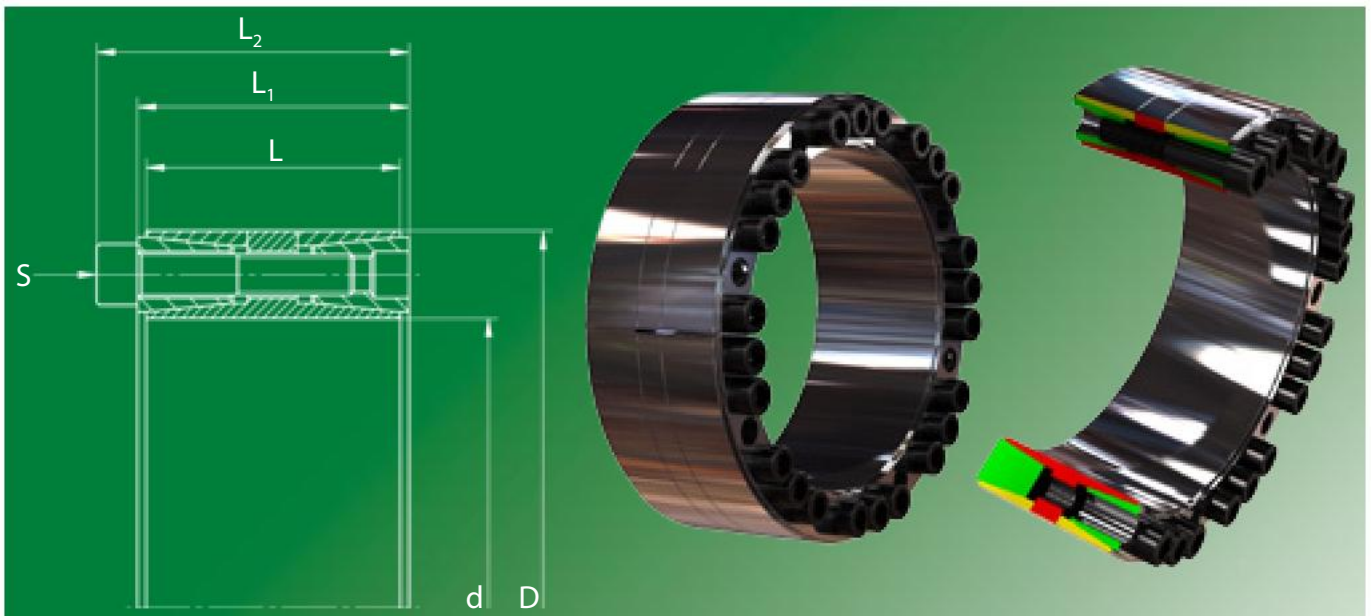

## Used symbols

$d$	[mm]	Shaft diameter	
$D$	[mm]	Hub inside diameter	
$M_t$	[Nm]	Max. transmittable torque	$F_{ax} = 0$
$F_{ax}$	[kN]	Max. transmittable axial force	$M_t = 0$
$p_w$	[N/mm <sup>2</sup> ]	Average pressure on the shaft	
$p_n$	[N/mm <sup>2</sup> ]	Average pressure on the hub	
$L$	[mm]	Length of the bush	
$L_1$	[mm]	Width of the locking device without screws	
$L_2$	[mm]	Width of the locking device with screws	
$Z$		Number of clamping screws	
$S$		Size of the clamping screws	
$M_A$		Tightening torque of the clamping screws	

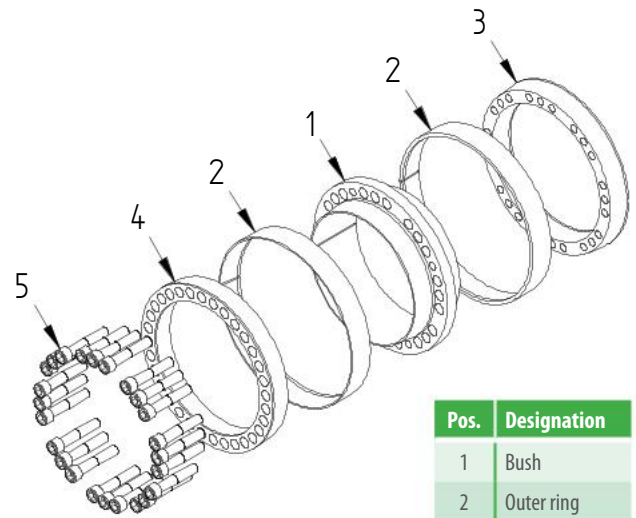

Pos.	Designation
1	Bush
2	Outer ring
3	Pressure ring 1
4	Pressure ring 2
5	Screw

## Recommended tolerances & surfaces

Shaft	h8 / Rz10
Hub	H8 / Rz10

## Bending loads

Bending moment (share)	$M_b \text{ max} = 0,35 * M_t$
Bending angle	max. 5°

## More properties

- no axial displacement during assembly
- good self-centering
- low self-locking

Ordering information: TAS 3015.1 DK/d/D (for example: TAS 3015.1 DK/150/200 ... further sizes on request)

# 3015.1 DK

<b>d</b> mm		<b>D</b> mm	<b>M<sub>t</sub></b> Nm	<b>F<sub>ax</sub></b> kN	<b>P<sub>w</sub></b> N/mm <sup>2</sup>	<b>P<sub>N</sub></b> N/mm <sup>2</sup>	<b>Z</b> Stk	<b>S</b>	<b>M<sub>A</sub></b> Nm	<b>L</b> mm	<b>L<sub>1</sub></b> mm	<b>L<sub>2</sub></b> mm	<b>Weight</b> kg
100	x	145	7000	139	101	69	9	M10 x 055	83	60	65	75	4,1
110	x	155	8500	155	102	72	10	M10 x 055	83	60	65	75	4,4
120	x	165	11100	185	112	81	12	M10 x 055	83	60	65	75	4,8
130	x	180	15100	232	109	79	15	M10 x 060	83	68	74	84	6,5
140	x	190	16200	232	101	75	15	M10 x 060	83	68	74	84	7,0
150	x	200	18500	247	101	76	16	M10 x 060	83	68	74	84	7,4
160	x	210	22300	278	106	81	18	M10 x 060	83	68	74	84	7,8
170	x	225	29100	343	111	84	15	M12 x 065	145	75	81	93	10,0
180	x	235	32900	365	111	85	16	M12 x 065	145	75	81	93	10,6
190	x	250	39100	411	101	77	18	M12 x 075	145	88	94	106	14,3
200	x	260	45700	457	107	82	20	M12 x 075	145	88	94	106	15,0
220	x	285	52800	480	98	75	21	M12 x 080	145	98	104	116	19,8
240	x	305	65800	548	102	81	24	M12 x 080	145	98	104	116	21,4
260	x	325	80200	617	106	85	27	M12 x 080	145	98	104	116	23,0
280	x	355	120200	858	111	87	28	M14 x 100	230	120	126	140	35,2
300	x	375	128700	858	104	83	28	M14 x 100	230	120	126	140	37,4
320	x	405	188500	1178	114	90	28	M16 x 110	355	135	142	158	51,3
340	x	425	200300	1178	107	86	28	M16 x 110	355	135	142	158	54,1
360	x	455	220400	1225	90	71	24	M18 x 140	485	158	165	183	75,4
380	x	475	261800	1378	96	77	27	M18 x 140	485	158	165	183	79,0
400	x	495	326600	1633	108	87	32	M18 x 140	485	158	165	183	82,8
420	x	515	342900	1633	103	84	32	M18 x 140	485	158	165	183	86,5
440	x	545	389600	1771	97	78	27	M20 x 140	690	172	180	200	110
460	x	565	407300	1771	93	76	27	M20 x 140	690	172	180	200	114
480	x	585	472200	1968	99	81	30	M20 x 140	690	172	180	200	119
500	x	605	491900	1968	95	78	30	M20 x 140	690	172	180	200	123
520	x	630	545700	2099	86	71	32	M20 x 150	690	190	200	220	148
540	x	650	566700	2099	83	69	32	M20 x 150	690	190	200	220	154
560	x	670	661100	2361	90	75	36	M20 x 150	690	190	200	220	160
580	x	690	684700	2361	86	73	36	M20 x 150	690	190	200	220	165
600	x	710	708300	2361	84	71	36	M20 x 150	690	190	200	220	170
620	x	730	731900	2361	81	69	36	M20 x 150	690	190	200	220	175
640	x	750	755500	2361	78	67	36	M20 x 150	690	190	200	220	180

# 3020



## Used symbols

$d$	[mm]	Shaft diameter	
$D$	[mm]	Hub inside diameter	
$M_t$	[Nm]	Max. transmittable torque	$F_{ax} = 0$
$F_{ax}$	[kN]	Max. transmittable axial force	$M_t = 0$
$p_w$	[N/mm <sup>2</sup> ]	Average pressure on the shaft	
$p_N$	[N/mm <sup>2</sup> ]	Average pressure on the hub	
$L$	[mm]	Length of the bush	
$L_1$	[mm]	Width of the locking device without screws	
$L_2$	[mm]	Width of the locking device with screws	
$Z$		Number of clamping screws	
$S$		Size of the clamping screws	
$M_A$		Tightening torque of the clamping screws	

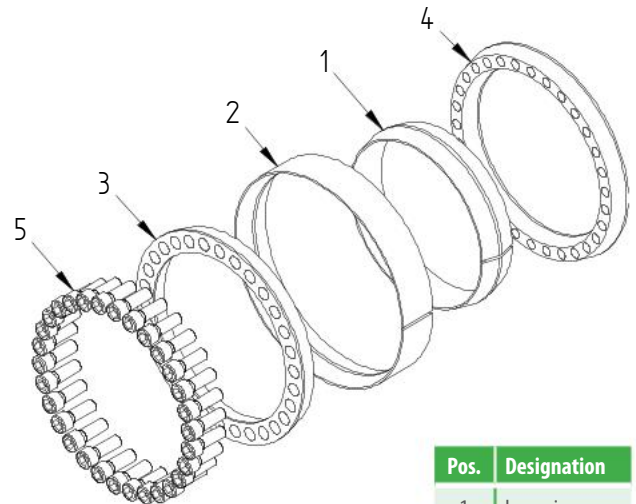

Pos.	Designation
1	Inner ring
2	Outer ring
3	Pressure ring 1
4	Pressure ring 2
5	Screw

## Recommended tolerances & surfaces

Shaft	h8 / Rz10
Hub	H8 / Rz10

## Bending loads

Bending moment (share) depending on hub  
 Bending angle max. 2°

## More properties

- no axial displacement during assembly
- no self-centering
- no self-locking

Ordering information: TAS 3020/d/D (for example: TAS 3020/150/200 ... further sizes on request)

<b>d</b> mm		<b>D</b> mm	<b>M<sub>t</sub></b> Nm	<b>F<sub>ax</sub></b> kN	<b>P<sub>w</sub></b> N/mm <sup>2</sup>	<b>P<sub>N</sub></b> N/mm <sup>2</sup>	<b>Z</b> Stk	<b>S</b>	<b>M<sub>A</sub></b> Nm	<b>L</b> mm	<b>L<sub>1</sub></b> mm	<b>L<sub>2</sub></b> mm	<b>Weight</b> kg
17	x	47	260	32	291	105	8	M6 x 018	17	17	20	27,5	0,2
18	x	47	280	32	275	105	8	M6 x 018	17	17	20	27,5	0,2
19	x	47	300	32	260	105	8	M6 x 018	17	17	20	27,5	0,2
20	x	47	310	32	247	105	8	M6 x 018	17	17	20	27,5	0,2
22	x	47	340	32	225	105	8	M6 x 018	17	17	20	27,5	0,2
24	x	50	380	32	206	99	8	M6 x 018	17	17	20	27,5	0,2
25	x	50	390	32	198	99	8	M6 x 018	17	17	20	27,5	0,2
28	x	55	660	48	265	135	12	M6 x 018	17	17	20	27,5	0,2
30	x	55	710	48	247	135	12	M6 x 018	17	17	20	27,5	0,2
32	x	60	760	48	232	124	12	M6 x 018	17	17	20	27,5	0,3
35	x	60	830	48	212	124	12	M6 x 018	17	17	20	27,5	0,2
38	x	65	1100	59	244	143	15	M6 x 018	15	17	20	27,5	0,3
40	x	65	1100	59	232	143	15	M6 x 018	17	17	20	27,5	0,3
42	x	75	1800	88	278	156	12	M8 x 022	41	20	24	33,5	0,5
45	x	75	1900	88	259	156	12	M8 x 022	41	20	24	33,5	0,4
48	x	80	2100	88	243	146	12	M8 x 022	41	20	24	33,5	0,5
50	x	80	2100	88	233	146	12	M8 x 022	41	20	24	33,5	0,5
55	x	85	3000	110	265	172	15	M8 x 022	41	20	24	33,5	0,5
60	x	90	3200	110	243	162	15	M8 x 022	41	20	24	33,5	0,6
65	x	95	3500	110	224	153	15	M8 x 022	41	20	24	33,5	0,6
70	x	110	6300	181	286	182	15	M10 x 025	83	24	28	39,5	1,1
75	x	115	6700	181	267	174	15	M10 x 025	83	24	28	39,5	1,1
80	x	120	7200	181	250	167	15	M10 x 025	83	24	28	39,5	1,2
85	x	125	7700	181	236	160	15	M10 x 025	83	24	28	39,5	1,2
90	x	130	8100	181	223	154	15	M10 x 025	83	24	28	39,5	1,3
95	x	135	10300	218	253	178	18	M10 x 025	83	24	28	39,5	1,4
100	x	145	13300	268	273	189	15	M12 x 030	145	26	33	47	1,8
110	x	155	14700	268	248	176	15	M12 x 030	145	26	33	47	1,9
120	x	165	17100	286	243	177	16	M12 x 030	145	26	33	47	2,1
130	x	180	23200	357	214	155	20	M12 x 035	145	34	38	52	3,2
140	x	190	27500	393	219	161	22	M12 x 035	145	34	38	52	3,5
150	x	200	32100	429	223	167	24	M12 x 035	145	34	38	52	3,7
160	x	210	37100	464	226	173	26	M12 x 035	145	34	38	52	3,9
170	x	225	44800	527	217	164	22	M14 x 040	230	38	44	60	5,1
180	x	235	51700	575	223	171	24	M14 x 040	230	38	44	60	5,3
190	x	250	63700	671	204	155	28	M14 x 045	230	46	52	68	7,5
200	x	260	71900	719	207	159	30	M14 x 045	230	46	52	68	7,8
220	x	285	94000	855	206	159	26	M16 x 050	355	50	56	74	10,1
240	x	305	118000	987	218	172	30	M16 x 050	355	50	56	74	10,9
260	x	325	145000	1119	228	183	34	M16 x 050	355	50	56	74	11,7
280	x	355	178000	1277	202	159	32	M18 x 060	485	60	66	86,5	17,6
300	x	375	215000	1436	212	169	36	M18 x 060	485	60	66	86,5	18,7
320	x	405	295000	1846	213	168	36	M20 x 070	690	72	78	100,5	27,4
340	x	425	313000	1846	200	160	36	M20 x 070	690	72	78	100,5	28,9
360	x	455	414000	2303	202	160	36	M22 x 080	930	84	90	116	40,1
380	x	475	437000	2303	191	153	36	M22 x 080	930	84	90	116	42,1

# 3020

<b>d</b> mm	<b>D</b> mm	<b>M<sub>t</sub></b> Nm	<b>F<sub>ax</sub></b> kN	<b>p<sub>w</sub></b> N/mm <sup>2</sup>	<b>p<sub>N</sub></b> N/mm <sup>2</sup>	<b>Z</b> Stk	<b>S</b>	<b>M<sub>A</sub></b> Nm	<b>L</b> mm	<b>L<sub>1</sub></b> mm	<b>L<sub>2</sub></b> mm	<b>Weight</b> kg
400	x 495	460000	2303	182	147	36	M22 x 080	930	84	90	116	44,0
420	x 515	537000	2559	192	157	40	M22 x 080	930	84	90	116	46,0
440	x 545	658000	2992	188	152	40	M24 x 090	1200	96	102	127	61,2
460	x 565	688000	2992	180	146	40	M24 x 090	1200	96	102	130	63,7
480	x 585	753000	3142	181	148	42	M24 x 090	1200	96	102	130	66,2
500	x 605	822000	3291	182	150	44	M24 x 090	1200	96	102	130	68,7
520	x 630	889000	3422	182	150	45	M24x090	1200	96	102	130	74,9
540	x 650	923000	3422	175	145	45	M24x090	1200	96	102	127	77,5
560	x 670	1022000	3650	180	151	48	M24x090	1200	96	102	130	80,1
580	x 690	1102000	3802	181	152	50	M24x090	1200	96	102	130	82,7
600	x 710	1140000	3802	175	148	50	M24x090	1200	96	102	130	85,3
620	x 730	1225000	3954	176	150	52	M24x090	1200	96	102	130	87,9
640	x 750	1314000	4106	177	151	54	M24x090	1200	96	102	130	90,5
660	x 770	1405000	4258	178	153	56	M24x090	1200	96	102	130	93,1
680	x 790	1447000	4258	173	149	56	M24x090	1200	96	102	130	95,7
700	x 810	1596000	4563	180	156	60	M24x090	1200	96	102	130	98,3



# 4006



Pos.	Designation
1	Bush
2	Pressure ring 1
3	Pressure ring 2
4	Screw S <sub>2</sub>
5	Screw S <sub>1</sub>

## Used symbols

- $d$  [mm] Shaft diameter
- $D$  [mm] Hub inside diameter
- $M_{t1}$  [Nm] Max. transmittable torque pressure ring 1
- $F_{ax1}$  [kN] Max. transmittable axial force pressure ring 1
- $M_{t2}$  [Nm] Max. transmittable torque pressure ring 2
- $F_{ax2}$  [kN] Max. transmittable axial force pressure ring 2
- $M_{T1+2}$  [Nm] Entire transmittable torque  $F_{ax} = 0$
- $F_{ax1+2}$  [kN] Entire transmittable axial force  $M_t = 0$
- $p_{W1}$  [N/mm<sup>2</sup>] Average pressure on the shaft
- $p_{N1}$  [N/mm<sup>2</sup>] Average pressure on the hub 1
- $p_{W2}$  [N/mm<sup>2</sup>] Average pressure on the shaft
- $p_{N2}$  [N/mm<sup>2</sup>] Average pressure on the hub 2
- $L$  [mm] Length of the bush
- $L_0$  [mm] Distance pressure ring 2
- $L_1$  [mm] Width of the locking device without screws
- $L_2$  [mm] Width of the locking device with screws
- $L_3$  [mm] Distance pressure ring 1
- $L_5$  [mm] Width of the pressure rings
- $Z_1$  &  $Z_2$  Number of clamping screws
- $S_1$  &  $S_2$  Size of the clamping screws
- $M_{A1}$  &  $M_{A2}$  Tightening torque of the clamping screws

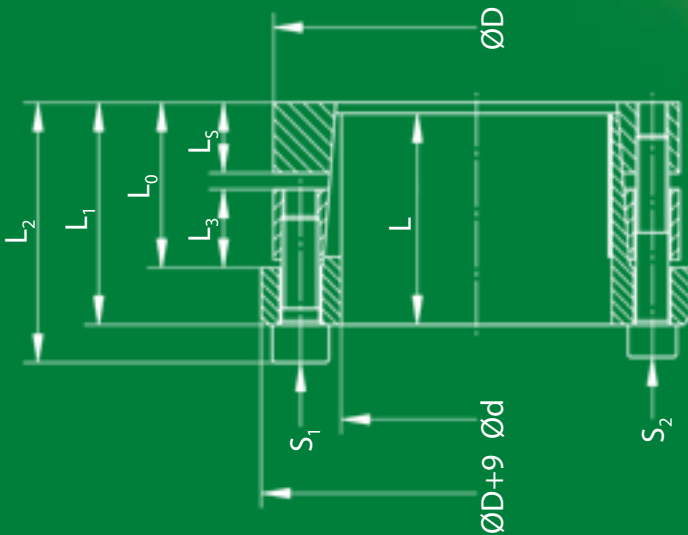

## Bending loads

Bending moment (share)  
Bending angle

$M_b \max = 0,6 \cdot M_t$   
max. 5°

## Recommended tolerances

Shaft h8  
Hub H8

## More properties

- no axial displacement during assembly
- very good self-centering
- high self-locking

$d$ mm	$D$ mm	$M_{t1}$ Nm	$F_{ax1}$ kN	$M_{t2}$ Nm	$F_{ax2}$ kN	$M_{T1+2}$ Nm	$F_{ax1+2}$ kN	$p_{W1}$ N/mm <sup>2</sup>	$p_{N1}$ N/mm <sup>2</sup>	$p_{W2}$ N/mm <sup>2</sup>	$p_{N2}$ N/mm <sup>2</sup>	$Z_1$ Stk	$S_1$	$M_{A1}$ Nm	$Z_2$ Stk	$S_2$	$M_{A2}$ Nm	$L$ mm	$L_0$ mm	$L_1$ mm	$L_2$ mm	$L_3$ mm	$L_5$ mm	Weight kg
30	x 60	623	42	342	23	965	64	245	124	134	67	4	M8x25	41	4	M6x40	17	45	36	48	56	18	15	0,95
35	x 65	727	42	499	29	1226	70	210	115	144	78	4	M8x25	41	5	M6x40	17	45	36	48	56	18	15	1,00
40	x 70	1039	52	570	29	1609	80	230	133	126	72	5	M8x25	41	5	M6x40	17	45	36	48	56	18	15	1,12
45	x 80	1516	67	1166	52	2682	119	221	126	170	95	4	M10x25	83	5	M8x50	41	54	42	57	67	21	18	1,47
50	x 85	2105	84	1296	52	3401	136	248	148	153	90	5	M10x25	83	5	M8x50	41	54	42	57	67	21	18	1,58
55	x 90	2316	84	1426	52	3741	136	226	140	139	85	5	M10x25	83	5	M8x50	41	54	42	57	67	21	18	1,70
60	x 95	3032	101	1866	62	4898	163	248	159	153	96	6	M10x25	83	6	M8x50	41	54	42	57	67	21	18	1,81
65	x 100	3284	101	2022	62	5306	163	229	151	141	92	6	M10x25	83	6	M8x50	41	54	42	57	67	21	18	1,93

Ordering information: TAS 4006/d/D (for example: TAS 4006/030/060 ... further sizes on request)

# 4006

d	D	M <sub>A1</sub>	F <sub>ax1</sub>	M <sub>A2</sub>	F <sub>ax2</sub>	M <sub>A1+2</sub>	F <sub>ax1+2</sub>	P <sub>w1</sub>	P <sub>w1</sub>	P <sub>w2</sub>	Z <sub>1</sub>	S <sub>1</sub>	M <sub>A1</sub>	Z <sub>2</sub>	S <sub>2</sub>	M <sub>A2</sub>	L	L <sub>0</sub>	L <sub>1</sub>	L <sub>2</sub>	L <sub>3</sub>	L <sub>s</sub>	Weight	
mm	mm	Nm	kN	Nm	kN	Nm	kN	N/mm <sup>2</sup>	N/mm <sup>2</sup>	N/mm <sup>2</sup>	Stk	Nm	Nm	Stk	Nm	Nm	mm	mm	mm	mm	mm	mm	kg	
70	x 115	5140	147	3531	101	8672	248	232	143	159	97	6	M12x35	145	6	M10x60	83	70	56	74	86	27	24	3,60
80	x 125	6854	171	4709	118	11562	289	237	154	163	104	7	M12x35	145	7	M10x60	83	70	56	74	86	27	24	4,00
90	x 135	7711	171	5297	118	13008	289	210	142	145	96	7	M12x35	145	7	M10x60	83	70	56	74	86	27	24	4,38
100	x 150	11498	230	8698	174	20195	404	235	159	177	118	7	M14x40	230	7	M12x70	145	78	61	82	96	29	26	6,00
110	x 160	12647	230	9568	174	22215	404	213	149	161	111	7	M14x40	230	7	M12x70	145	78	61	82	96	29	26	6,50
120	x 170	13797	230	10437	174	24235	404	196	140	148	104	7	M14x40	230	7	M12x70	145	78	61	82	96	29	26	6,97
130	x 190	23804	366	17342	267	41146	633	249	170	181	124	8	M16x50	355	8	M14x80	230	90	71	95	111	35	30	11,0
140	x 200	25635	366	18676	267	44311	633	231	162	169	118	8	M16x50	355	8	M14x80	230	90	71	95	111	35	30	11,6
150	x 210	27466	366	20010	267	47476	633	216	154	157	112	8	M16x50	355	8	M14x80	230	90	71	95	111	35	30	13,0
160	x 220	29297	366	21344	267	50641	633	202	147	147	107	8	M16x50	355	8	M14x80	230	90	71	95	111	35	30	12,3
180	x 250	51375	571	32959	366	84334	937	210	151	135	97	8	M20x70	690	8	M16x100	355	114	92	122	142	45	40	22,1
200	x 270	71355	714	45776	458	117131	1171	237	175	152	112	10	M20x70	690	10	M16x100	355	114	92	122	142	45	40	24,3
220	x 290	78490	714	50354	458	128844	1171	215	163	138	105	10	M20x70	690	10	M16x100	355	114	92	122	142	45	40	26,3
240	x 310	102751	856	65918	549	168669	1406	237	183	152	118	12	M20x70	690	12	M16x100	355	114	92	122	142	45	40	28,6
260	x 330	109740	844	70402	542	180143	1386	215	170	138	109	12	M20x70	690	12	M16x100	355	114	92	122	142	45	40	30,6
280	x 365	143639	1026	98485	703	242124	1729	216	166	148	114	10	M24x80	1200	10	M20x120	690	135	108	144	168	50	45	46,5
300	x 385	153899	1026	105520	703	259419	1729	202	157	138	108	10	M24x80	1200	10	M20x120	690	135	108	144	168	50	45	49,3
320	x 405	196991	1231	135065	844	332056	2075	227	179	155	123	12	M24x80	1200	12	M20x120	690	135	108	144	168	50	45	52
340	x 425	244186	1436	167425	985	411611	2421	249	199	171	137	14	M24x80	1200	14	M20x120	690	135	108	144	168	50	45	54
360	x 445	258550	1436	177273	985	435823	2421	235	190	161	130	14	M24x80	1200	14	M20x120	690	135	108	144	168	50	45	57
380	x 465	311902	1642	213853	1126	525755	2767	255	208	175	143	16	M24x80	1200	16	M20x120	690	135	108	144	168	50	45	60
400	x 485	328318	1642	225109	1126	553426	2767	242	200	166	137	16	M24x80	1200	16	M20x120	690	135	108	144	168	50	45	64
420	x 505	344734	1642	236364	1126	581098	2767	230	192	158	131	16	M24x80	1200	16	M20x120	690	135	108	144	168	50	45	66
440	x 525	361150	1642	247619	1126	608769	2767	168	141	115	96	16	M24x80	1200	16	M20x140	690	167	147	178	202	80	59	70
460	x 545	377565	1642	258875	1126	636440	2767	160	135	110	93	16	M24x80	1200	16	M20x140	690	167	147	178	202	80	59	73
480	x 565	393981	1642	270130	1126	664112	2767	154	131	105	90	16	M24x80	1200	16	M20x140	690	167	147	178	202	80	59	76
500	x 585	461697	1847	316559	1266	778256	3113	166	142	114	97	18	M24x80	1200	18	M20x140	690	167	147	178	202	80	59	79
520	x 605	480165	1847	329221	1266	809386	3113	160	137	109	94	18	M24x80	1200	18	M20x140	690	167	147	178	202	80	59	82
540	x 625	498633	1847	341884	1266	840516	3113	154	133	105	91	18	M24x80	1200	18	M20x140	690	167	147	178	202	80	59	85
560	x 645	517101	1847	354546	1266	871647	3113	148	129	102	88	18	M24x80	1200	18	M20x140	690	167	147	178	202	80	59	88
580	x 665	595076	2052	408009	1407	1003085	3459	159	139	109	95	20	M24x80	1200	20	M20x140	690	167	147	178	202	80	59	91
600	x 685	615596	2052	422079	1407	1037675	3459	154	135	105	92	20	M24x80	1200	20	M20x140	690	167	147	178	202	80	59	94
620	x 705	636116	2052	436148	1407	1072264	3459	149	131	102	90	20	M24x80	1200	20	M20x140	690	167	147	178	202	80	59	98

Ordering information: TAS 4006/d/D (for example: TAS 4006/030/060 ... further sizes on request)

# 8006



## Used symbols

$d$	[mm]	Shaft diameter
$D$	[mm]	Hub inside diameter
$L$	[mm]	Length of the locking device
$l$	[mm]	Width of inner ring and outer ring
$A_t$	[mm <sup>2</sup> ]	Contact surface of the shaft
$F_o$	[N]	Pretension to eliminate tolerances (for unslitted version)
$F_A$	[N]	Clamping force required to apply pressure of $p = 100 \text{ N/mm}^2$
$T$	[Nm]	Max. transmittable torque (at $p = 100 \text{ N/mm}^2$ ) $F_{ax} = 0$
$F_{ax}$	[N]	Max. transmittable axial force (at $p = 100 \text{ N/mm}^2$ ) $T = 0$
$x$	[mm]	Distance between clamping flange and hub in relation to the number of clamping elements
$d_1$	[mm]	inner diameter spacer bushing
$D_1$	[mm]	outer diameter spacer bushing

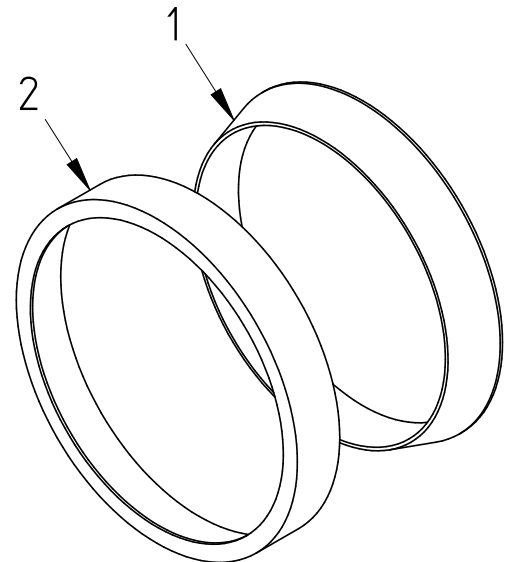

Pos.	Designation
1	Inner ring
2	Outer ring

## Recommended tolerances & surfaces

Shaft	h8 / Rz10
Hub	H8 / Rz10

## Bending loads

Bending moment (share)

Depending on hub design and number of clamping elements

## More properties

- axial displacement during assembly
- good self-centering
- no self-locking

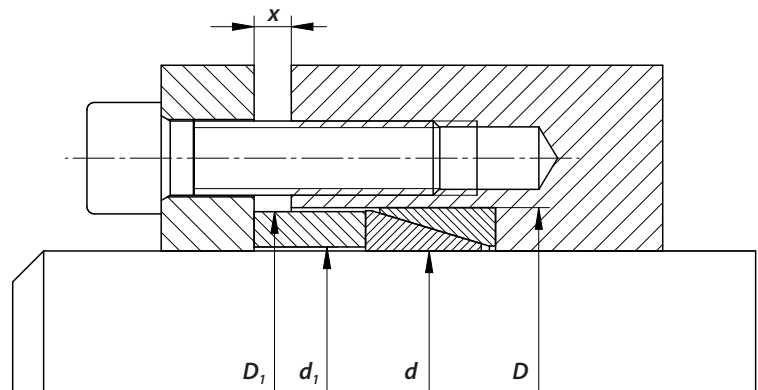

Ordering information: TAS 8006/d/D (for example: TAS 8006/150/200 ... further sizes on request)

TAS 8006/d/D slit (for example: TAS 8006/150/200 slit ... further sizes on request)

# 8006

d	D	L	l	A <sub>t</sub>	F <sub>o</sub>	F <sub>A</sub>	T	F <sub>ax</sub>	x				Weight	d <sub>1</sub>	D <sub>1</sub>
									1	2	3	4			
mm	mm	mm	mm	mm <sup>2</sup>	N	N	Nm	N	Spannelemente mm				kg	mm	mm
6	x 9	4,5	3,7	69	-	3240	2,16	720	2	2	3	3	0,00118	6,1	8,9
7	x 10	4,5	3,7	80	-	3780	2,94	840	2	2	3	3	0,00136	7,1	9,9
8	x 11	4,5	3,7	90	-	4300	3,84	960	2	2	3	3	0,00151	8,1	10,9
9	x 12	4,5	3,7	105	7600	5700	5,7	1270	2	2	3	3	0,00166	9,1	11,9
10	x 13	4,5	3,7	116	6950	6300	7	1400	2	2	3	3	0,00182	10,1	12,9
12	x 15	4,5	3,7	139	6950	7500	10	1670	2	2	3	3	0,00214	12,1	14,9
13	x 16	4,5	3,7	151	6450	8150	11,8	1810	2	2	3	3	0,00226	13,1	15,9
14	x 18	6,3	5,3	233	11200	12600	19,6	2800	3	3	4	5	0,00487	14,1	17,9
15	x 19	6,3	5,3	250	10750	13500	22,5	3000	3	3	4	5	0,00526	15,1	18,9
16	x 20	6,3	5,3	266	10100	14400	25,5	3190	3	3	4	5	0,00545	16,1	19,9
17	x 21	6,3	5,3	283	9550	15300	28,9	3400	3	3	4	5	0,0058	17,1	20,9
18	x 22	6,3	5,3	300	9100	16200	32,4	3600	3	3	4	5	0,00612	18,1	21,9
19	x 24	6,3	5,3	316	12600	17100	36	3790	3	3	4	5	0,00782	19,2	23,8
20	x 25	6,3	5,3	333	12050	18000	40	4000	3	3	4	5	0,00817	20,2	24,8
22	x 26	6,3	5,3	366	9050	19800	48	4400	3	3	4	5	0,00724	22,2	25,8
24	x 28	6,3	5,3	400	8350	21600	58	4800	3	3	4	5	0,00792	24,2	27,8
25	x 30	6,3	5,3	416	9900	22500	62	5000	3	3	4	5	0,0101	25,2	29,8
28	x 32	6,3	5,3	466	7400	25200	78	5600	3	3	4	5	0,00918	28,2	31,8
30	x 35	6,3	5,3	499	8500	27000	90	6000	3	3	4	5	0,012	30,2	34,8
32	x 36	6,3	5,3	533	7850	28800	102	6400	3	3	4	5	0,01	32,2	35,8
35	x 40	7	6	659	10100	35600	138	7900	3	3	4	5	0,017	35,2	39,8
36	x 42	7	6	678	11600	36600	147	8200	3	3	4	5	0,02	36,2	41,8
38	x 44	7	6	716	11000	38700	163	8600	3	3	4	5	0,021	38,2	43,8
40	x 45	8	6,6	829	13800	45000	199	9950	3	4	5	6	0,023	40,2	44,8
42	x 48	8	6,6	870	15600	47000	219	10400	3	4	5	6	0,028	42,2	47,8
45	x 52	10	8,6	1215	28200	66000	328	14600	3	4	5	6	0,042	45,2	51,8
48	x 55	10	8,6	1296	24600	70000	373	15600	3	4	5	6	0,045	48,2	54,8
50	x 57	10	8,6	1350	23500	73000	405	16200	3	4	5	6	0,047	50,2	56,8
55	x 62	10	8,6	1485	21800	80000	490	17800	3	4	5	6	0,05	55,2	61,8
56	x 64	12	10,4	1829	29400	99000	615	22000	3	4	5	7	0,067	56,2	63,8
60	x 68	12	10,4	1959	27400	106000	705	23500	3	4	5	7	0,072	60,2	67,8
63	x 71	12	10,4	2057	26300	111000	780	24800	3	4	5	7	0,077	63,2	70,8
65	x 73	12	10,4	2123	25400	115000	830	25600	3	4	5	7	0,079	65,2	72,8
70	x 79	14	12,2	2682	31000	145000	1120	32000	3	5	6	7	0,111	70,3	78,7
71	x 80	14	12,2	2720	31000	147000	1160	32600	3	5	6	7	0,113	71,3	79,7
75	x 84	14	12,2	2873	34600	155000	1290	34400	3	5	6	7	0,12	75,3	83,7
80	x 91	17	15	3768	48000	203000	1810	45000	4	5	6	8	0,188	80,3	90,7
85	x 96	17	15	4004	45600	216000	2040	48000	4	5	6	8	0,2	85,3	95,7
90	x 101	17	15	4239	43400	229000	2290	51000	4	5	6	8	0,216	90,3	100,7
95	x 106	17	15	4475	41200	242000	2550	54000	4	5	6	8	0,224	95,3	105,7
100	x 114	21	18,7	5872	60700	317000	3520	70000	4	6	7	9	0,38	100,3	113,7
110	x 124	21	18,7	6459	66000	349000	4250	77000	4	6	7	9	0,41	110,3	123,7
120	x 134	21	18,7	7046	60200	380000	5050	84000	4	6	7	9	0,452	120,3	133,7
130	x 148	28	25,3	10328	96200	558000	8050	124000	5	7	9	11	0,847	130,3	147,6

# 8006

<i>d</i>	<i>D</i>	<i>L</i>	<i>l</i>	<i>A<sub>t</sub></i>	<i>F<sub>o</sub></i>	<i>F<sub>A</sub></i>	<i>T</i>	<i>F<sub>ax</sub></i>	<i>x</i>				<i>Weight</i>	<i>d<sub>1</sub></i>	<i>D<sub>1</sub></i>
									1	2	3	4			
mm	mm	mm	mm	mm <sup>2</sup>	N	N	Nm	N	Spannelemente mm				kg	mm	mm
140	x 158	28	25,3	11122	89000	600000	9350	134000	5	7	9	11	0,91	140,3	157,6
150	x 168	28	25,3	11916	84500	643000	10700	143000	5	7	9	11	0,967	150,4	167,6
160	x 178	28	25,3	12711	78500	686000	12200	152500	5	7	9	11	1,023	160,4	177,6
170	x 191	33	30	16014	117500	865000	16300	192000	6	8	10	12	1,5	170,4	190,5
180	x 201	33	30	16956	111200	916000	18300	204000	6	8	10	12	1,58	180,5	200,5
190	x 211	33	30	17898	105000	966000	20400	214000	6	8	10	12	1,68	190,5	210,5
200	x 224	38	34,8	21854	134000	1180000	26200	262000	6	8	11	13	2,32	200,6	223,4
210	x 234	38	34,8	22947	127000	1239000	28900	275000	6	8	11	13	2,45	210,6	233,4
220	x 244	38	34,8	24040	122000	1298000	31700	288000	6	8	11	13	2,49	220,6	243,4
230	x 257	43	39,5	28527	165000	1540000	39400	342000	6	9	12	14	3,38	230,6	256,4
240	x 267	43	39,5	29767	157500	1610000	43000	358000	6	9	12	14	3,52	240,6	266,4
250	x 280	48	44	34700	190000	1870000	52000	415000	7	10	13	16	4,68	250,8	279,2
260	x 290	48	44	36100	182000	1950000	56500	435000	7	10	13	16	4,82	260,8	289,2
270	x 300	48	44	37500	177000	2030000	61000	450000	7	10	13	16	4,94	270,8	299,2
280	x 313	53	49	43100	206000	2330000	72500	520000	7	10	14	17	6,27	280,8	312,2
290	x 323	53	49	44600	222000	2410000	77500	535000	7	11	14	17	6,5	290,8	332,2
300	x 333	53	49	46200	214000	2490000	83000	555000	7	11	14	17	6,74	300,8	322,2
320	x 360	65	59	59300	292000	3200000	114000	710000	10	15	20	25	10,9	321	359
340	x 380	65	59	63000	272000	3400000	128500	755000	10	15	20	25	11,5	341	379
360	x 400	65	59	66700	258000	3600000	144000	800000	10	15	20	25	12,2	361	399
380	x 420	65	59	70400	269000	3800000	160500	845000	10	15	20	25	12,8	381	419
400	x 440	65	59	74200	256000	4000000	178000	890000	10	15	20	25	13,5	401	439
420	x 460	65	59	77800	244000	4200000	196000	935000	10	15	20	25	14,1	421	459
440	x 480	65	59	81500	234000	4400000	215000	980000	10	15	20	25	14,7	441	479
460	x 500	65	59	85300	224000	4600000	235000	1020000	10	15	20	25	15,4	461	499
480	x 520	65	59	89000	239000	4800000	256000	1070000	10	15	20	25	16	481	519
500	x 540	65	59	92700	229000	5000000	278000	1110000	10	15	20	25	16,6	501	539

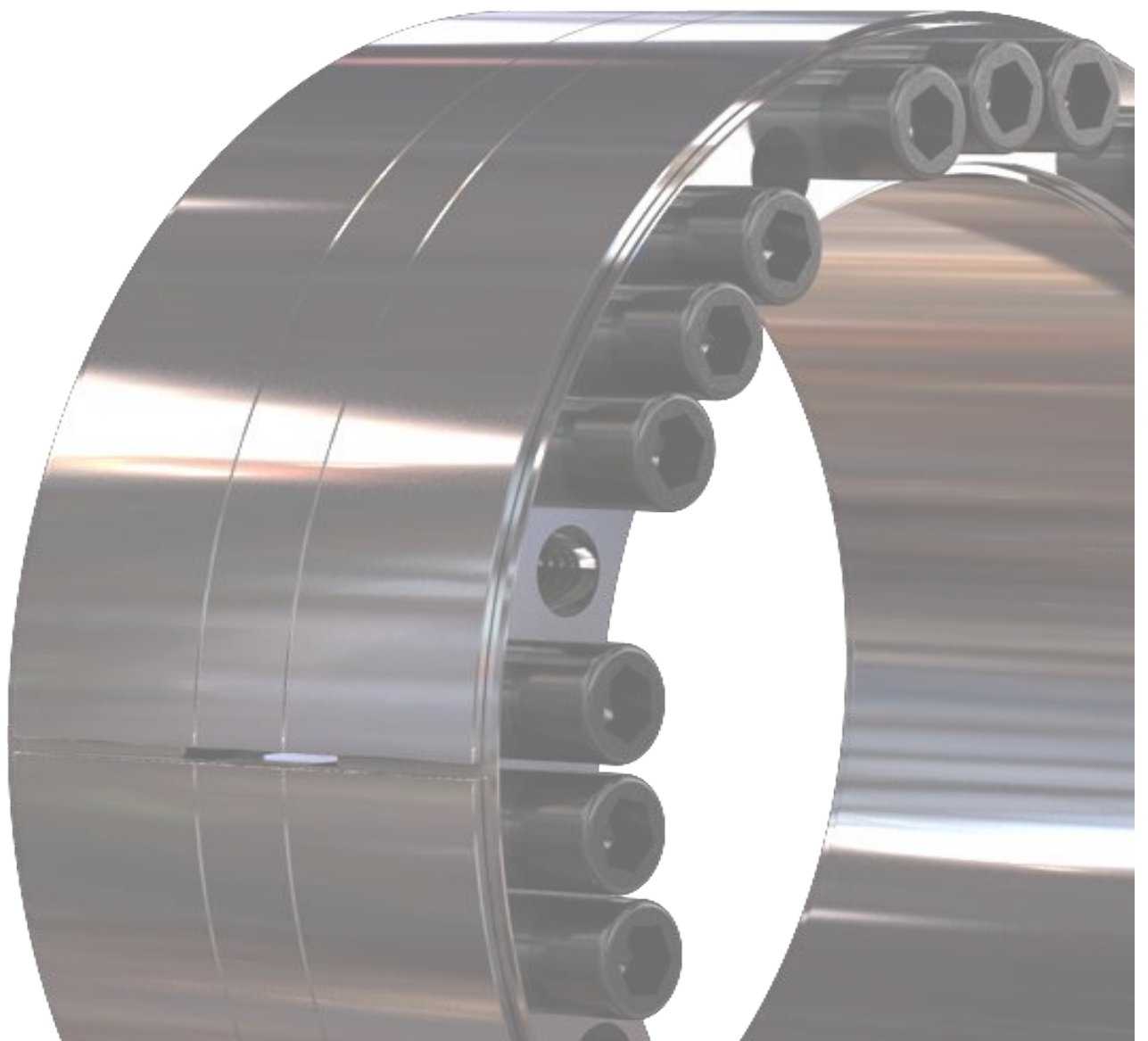



# Special design

For the following product features, please send us a separate request:

Other dimensions

Stainless steel designs

Split versions (e.g. TAS 3020 in very large-sized)

Galvanized or nickel plated surfaces

Countersunk screws

Reduced surface pressure

...



# Further products from our company

## Shrink discs in two-parts design



TAS 3173



TAS 3171, 3181, 3191, 3193

## Shrink discs in three-parts design



TAS 3073



TAS 3051, 3071, 3081,  
3091, 3093



Split



Half-G



Half-D

## Rigid Shaft couplings



TAS W



TAS WK



TAS WLA



TAS WLB



TAS AFS

## Flange couplings



TAS FK



TAS FKB



TAS FKBS

## Hydraulic actuated shrink discs



TAS SHS

## Hydraulic actuated flange coupling



TAS FKH

## Hydraulic actuated shaft coupling



TAS WHS



**TAS Schäfer GmbH**

Osterfeldstraße 75

58300 Wetter (Ruhr)

Phone: +49 (0) 2335 9781-0

FAX: +49 (0) 2335 72956

E-Mail: [info@tas-schaefer.de](mailto:info@tas-schaefer.de)

Internet: [www.tas-schaefer.de](http://www.tas-schaefer.de)