

# Linear Rail System

## SBI High-load Linear Rail System

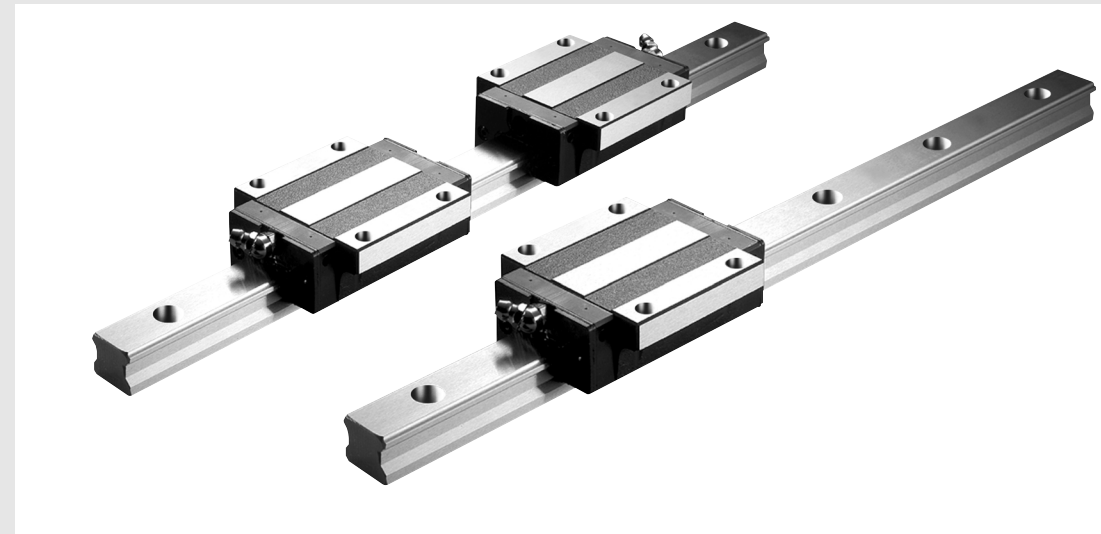

### Circular arc groove

Two point contact structure of circular arc groove. It keeps the function of self-aligning and smooth rolling performance.

### 45° angle of contact

Four rows of circular arc groove contact balls at an angle of 45 degrees provides the same capacity in all directions.

### DF structure

### Low noise and High rigidity

Optimized ball recirculation structure and design provides low noise and high-rigidity.

### The same dimension

The dimension of height, width and mounting holes are the same as SBG series, with only a slight variation in block length.

# Linear Rail System

## SBI High-load Linear Rail System

### The feature of structure

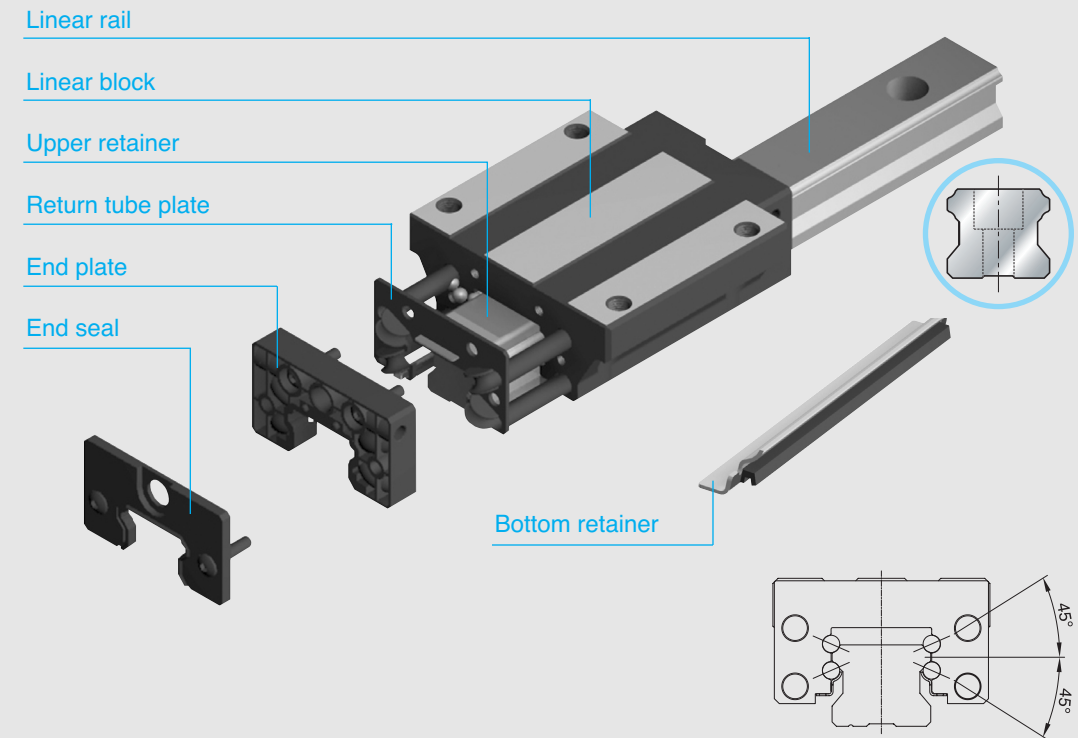

**End seal** New double lip structure which improves resistance to dust and particle contamination.

**End-plate** Manufactured with a new high rigidity engineered plastic. Designed to withstand the highest of unplanned impact loads without breaking.

**Retainer** Ball retainer plates now snap assembled to the blocks and this unique assembly method allows an amount of internal self-alignment and load sharing while maintaining rigid ball control.

**Return tube plate** The end plate and reversing ramps of new ball return tubes are now molded as one complete body. This allows for smoother ball rotation through the critical transition points, significantly improving rolling performance, lower operating better lubricant retention inside the bearing.

**Linear block** Highly rigid structure with a larger recirculation radius for the smooth movement and longer block length for higher load capacity.

**Linear rail** SBI rail is designed with a low profile and wide base. This characteristic allows greater stability in operation and during manufacture. Results in greater linear precision.

### [Low noise]

- SBI25 / SBG25 noise level test data

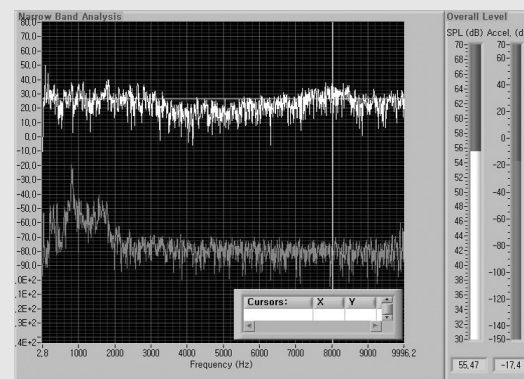
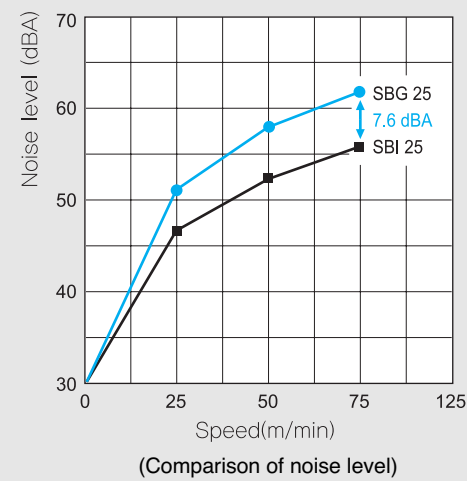

(SBI 1.3m/sec)

### [High load performance]

SBI type is improved load capacity from the longer block length and changed radius of curvature

- The comparison of SBI / SBG block length

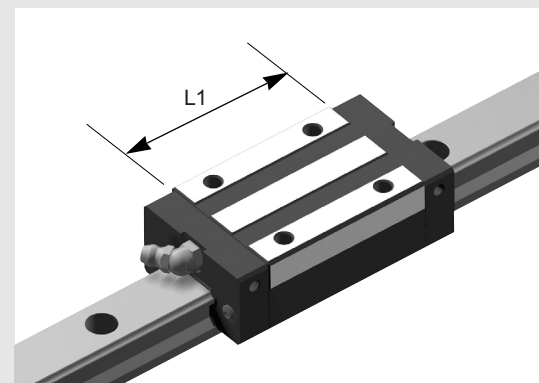

(Unit : mm)

L1 length	SBG	SBI
15SL	38.8	45.2
20SL	50.8	56.8
25SL	59.5	70

- The comparison of basic dynamic load rating

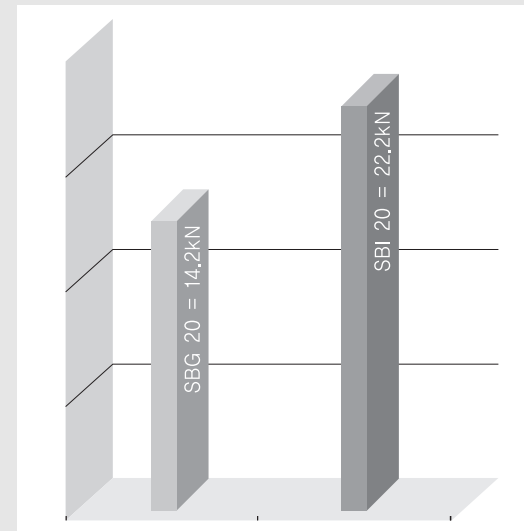

(Comparison of basic dynamic load rating)

Improved geometry and tolerances increases basic dynamic load rating

- Comparison of lifetime calculation

- L (km) : Nominal life
- C (kN) : Basic dynamic load rating
- P (kN) : Calculated load

$$L = \left( \frac{C}{P} \right)^3 \times 50 \text{ km}$$

In case of P = 5 kN

Basic dynamic load rating (C) of SBI20 SL : 22.2 kN

Basic dynamic load rating (C) of SBG20 SL : 14.2 kN

$$\text{SBI 20SL} : L = \left( \frac{C}{P} \right)^3 \times 50 = \left( \frac{22.2}{5} \right)^3 \times 50 = 4376 \text{ km}$$

$$\text{SBG 20SL} : L = \left( \frac{C}{P} \right)^3 \times 50 = \left( \frac{14.2}{5} \right)^3 \times 50 = 1145 \text{ km}$$

### Accuracy

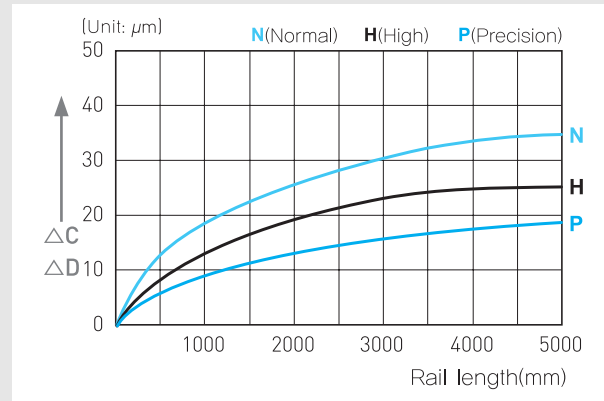
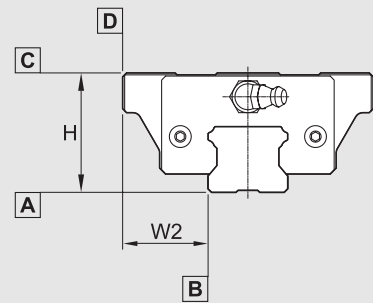

(Unit : mm)

Item	N	H	P
Tolerance for the height <b>H</b>	±0.1	±0.04	±0.02
Tolerance for the rail-to-block lateral distance <b>W2</b>	±0.1	±0.04	±0.02
Tolerance for the height <b>H</b> difference among blocks	0.03	0.015	0.007
Tolerance for rail-to-block lateral distance <b>W2</b> distance among blocks	0.03	0.015	0.007
Running parallelism of surface <b>C</b> with surface <b>A</b>		ΔC	
Running parallelism of surface <b>D</b> with surface <b>B</b>		ΔD	

● N : Normal    ● H : High    ● P : Precision

### Preload

Reference	Volume of preload
K0 (None)	Clearance within 0.01mm
K1 (Normal)	0.00 ~ 0.02C
K2 (Light)	0.04 ~ 0.06C
K3 (Heavy)	0.08 ~ 0.10C

● C(kN) : Basic dynamic load rating

※ "K3" Preload is not available for SBI15 type

### Shoulder height and fillet radius R

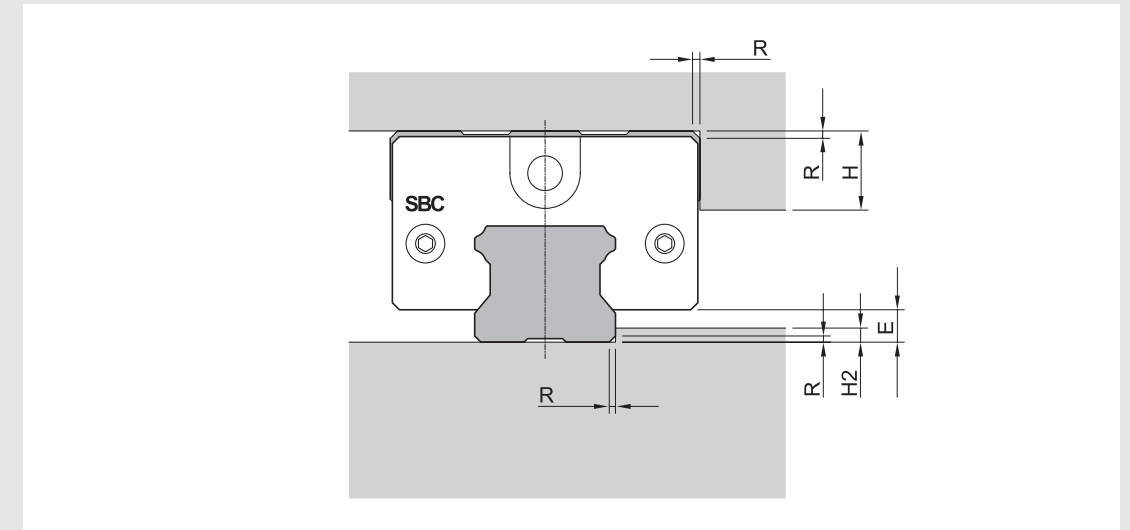

(Unit : mm)

Model number	Fillet radius R	Shoulders height H1	Shoulders height H2	E
15	0.6	7	2.5	3
20	1	8	3.5	4.6
25	1	10	4.5	5.5
30	1	11	5	7
35	1	13	6	7.5
45	1.6	16	8	9

# Linear Rail System

## SBI High-load Linear Rail System

### Permissible tolerance (P) of parallelism

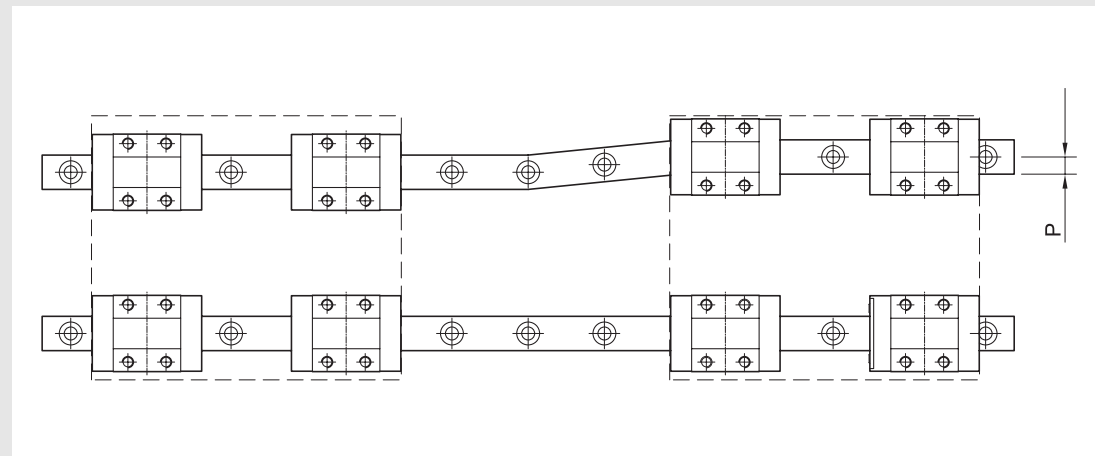

(Unit : mm)

Model size	K1	K2	K3
15	0.025	0.018	-
20	0.025	0.020	0.018
25	0.030	0.022	0.020
30	0.040	0.030	0.027
35	0.050	0.035	0.030
45	0.060	0.040	0.035

# Linear Rail System

## SBI High-load Linear Rail System

### Permissible tolerance (S) of two level offset

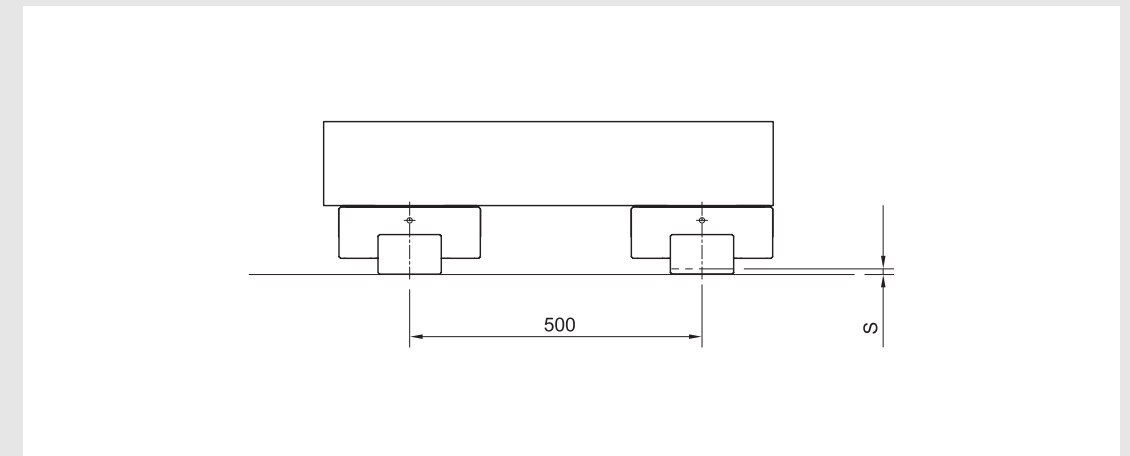

(Unit : mm)

Model size	K1	K2	K3
15	0.13	0.085	-
20	0.13	0.085	0.05
25	0.13	0.085	0.07
30	0.17	0.11	0.09
35	0.21	0.15	0.12
45	0.25	0.17	0.14

### SH Bellows

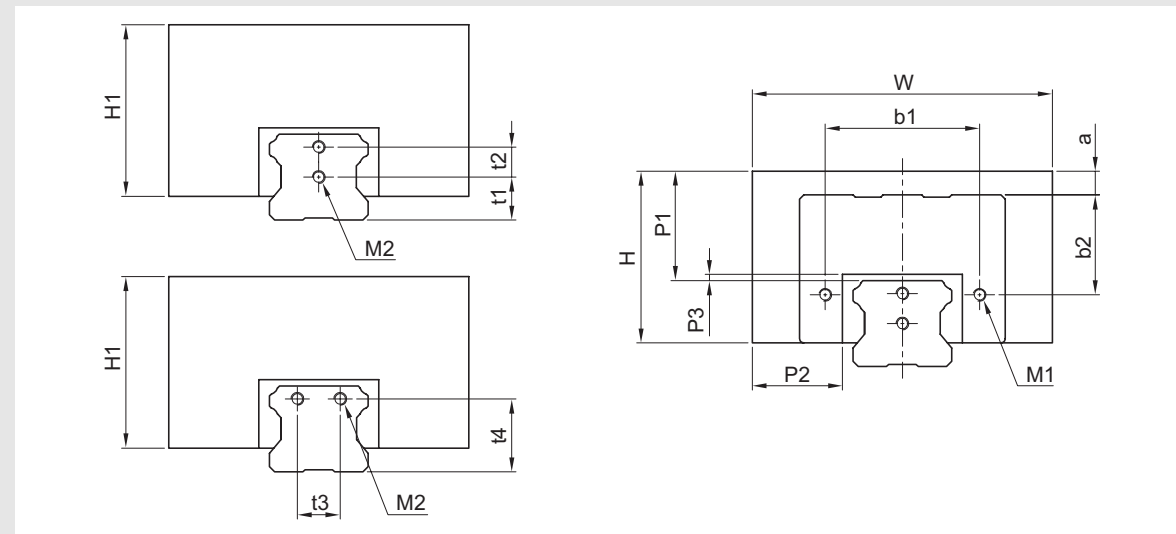

Model number	Applicable type	W	H	H1	P1	P2	P3	a						b1
								FV	SV	CL/CLL	FL/FLL	SL/SLL	HL/HLL	
SH15 A	SBI15	50	25	25	15	15.5	1	4	4	-	4	0	4	26
SH15 DA			20	20	10			-1	-1	-	-1	-5	-1	
SH20 A	SBI20	60	29	31	17	18	1	5.5	5.5	5.5	3.5	3.5	-	34
SH20 DA			24	26	12			-	-	-	-1.5	-1.5	-	
SH25 A	SBI25	70	35	35	20	21	1	7	7	7	4	0	4	36
SH25 DA			30	30	15			-	-	-	-1	-5	-1	
SH30 A	SBI30	80	36	36	20	23	1	-	-	-	1	-2	1	49
SH30 DA			33	33	17			-	-	-	-2	-5	-2	
SH35 DA	SBI35	85	39	39	20	22.5	1	-	-	-	-2	-9	-2	56
SH45 DA	SBI45	100	48	48	25	25	1	-	-	-	-3	-13	-3	72

\* If you use SH bellows, rain end mounting holes must be provided

\* Please contact SBC for lubricant with SH bellows.

[Calculation of bellows length]

$$A = \frac{L_{max}}{L_{min}}$$

- L<sub>max</sub> : Extended length (mm)
- L<sub>min</sub> : Collapsed length (mm)

	L <sub>min</sub>	L <sub>max</sub>
*SBI 15, 20	Stroke ÷ 5	L <sub>min</sub> + Stroke
*SBI 25~45	Stroke ÷ 6	

(Unit : mm)

b2						t1	t2	t3	t4	M		A Extended ratio
FV	SV	CL/CLL	FL/FLL	SL/SLL	HL/HLL					M1(Block)	M2(Rail)	
13.3	13.3	-	13.3	17.3	13.3	10	-	-	-	M3X15L	M4X8L	6
14	14	14	16	16	-	6	8	-	-	M3X18L	M3X6L	6
16.3	16.3	16.3	19.3	23.3	19.3	10	7	-	-	M3X18L	M3X6L	7
-	-	-	22.8	25.8	22.8	11	8	-	-	M4X22L	M4X8L	7
-	-	-	26.5	33.5	26.5	-	-	14	21	M4X22L	M4X8L	7
-	-	-	33.5	43.5	33.5	-	-	20	25	M4X25L	M5X10L	7

Ordering example : **SH25A - 70 / 420**

① ② ③

① Model number

② Collapsed length (mm)

③ Extended length (mm)

※ 'H' dimension of SH-DA type is lower than SH-A type

### RC Cap

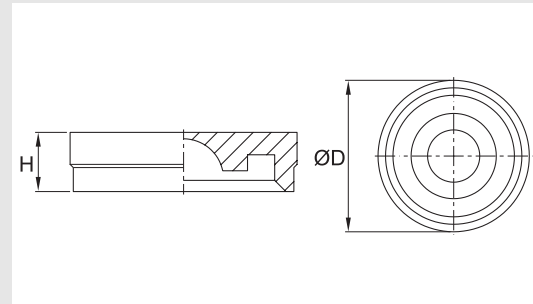

(Unit : mm)

Model	D	H
RC 15	7.7	1.5
RC 20	9.7	3.5
RC 25	11.2	2.8
*RC 30	14.2	3.7
RC 45	20.2	4.7

- RC 30 is used for SBI 30, 35 rail.
- SBI, SBG type use same RC cap.

### ST Tape

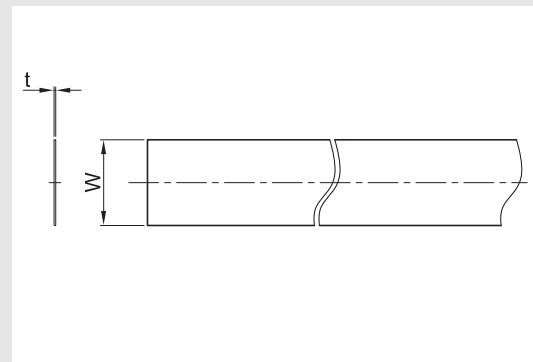

(Unit : mm)

Model	W	t
ST 15A	11	0.1
ST 20A	15	0.1
ST 25A	17	0.1
ST 30A	21	0.1
ST 35A	27	0.1
ST 45A	37	0.1

Ordering example : **ST15A - 1000L**

①      ②

- ① Model number
- ② Length

### Seal and MF container

[Method and overall length with each seal]

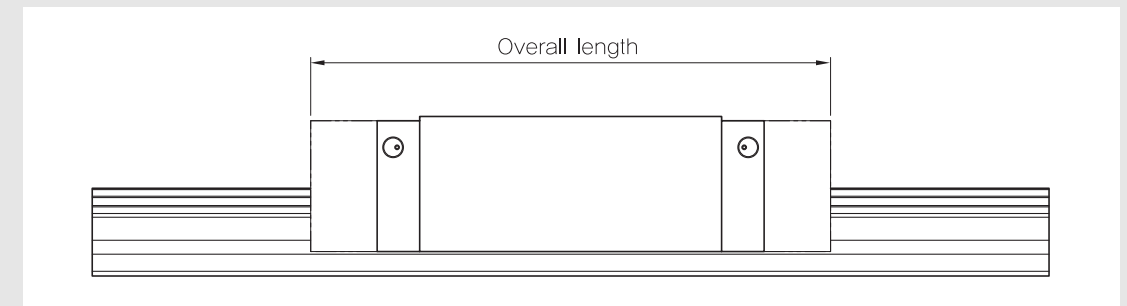

• E : End seal    S : Scraper    F : DF (High dust protection seal).    MF (Self lubricant)    (Unit : mm)

Additional seal	Standard	DD	ZZ	KK	MF (Self lubricant)			
		E	E+S	E+E+S	F+E	F+E+E	F+E+S	F+E+E+S
15V	39.9	44.5	45.3	49.9	53.9	58.5	59.3	63.9
15	63.8	68.4	69.2	73.8	77.8	82.4	83.2	87.8
15L	79.4	84	84.8	89.4	93.4	98	98.8	103.4
20V	49.1	54.1	54.5	59.5	63.1	68.1	68.5	73.5
20	78.8	83.8	84.2	89.2	92.8	97.8	98.2	103.2
20L	96.4	101.4	101.8	106.8	110.4	115.4	115.8	120.8
25V	52.6	57.6	58	63	66.6	71.6	72	77
25	92	97	97.4	102.4	106	111	111.4	116.4
25L	108	113	113.4	118.4	122	127	127.4	132.4
30	107.6	113.6	114	120	123.6	129.6	130	136
30L	131.6	137.6	138	144	147.6	153.6	154	160
35	124.6	130.6	131	137	140.6	146.6	147	153
35L	152.6	158.6	159	165	168.6	174.6	175	181
45	142	148	148.4	154.4	158	164	164.4	170.4
45L	174	180	180.4	186.4	190	196	196.4	202.4

- Bottom seal of SBI type is integrated with bottom retainer. (Except SBI15)
- If block is assembled with MF container, the grease fitting is not supplied. If you would like to feed the grease to the block, please order side grease fitting type.

### [Dimension of MF container]

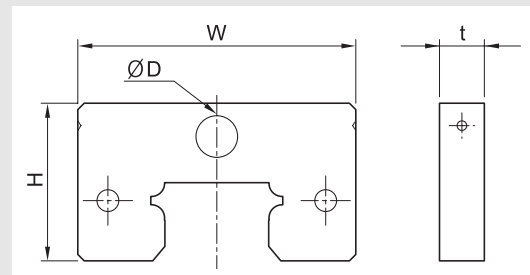

(Unit : mm)

Reference	Model	W	t	H	D
DF MF	15A	33.4	7	20.2	4
	20A	43.4	7	24.6	6.5
	25A	47	7	29.7	6.5
	30A	59	8	34.2	6.5
	35A	69	8	39.7	6.5
	45A	85	8	49.7	8.5

### [Seal resistance]

For the maximum value of seal resistance of SBI standard type per block, in which grease is not applied.

※ Scraper has no resistance because it is not contacting rail.

(Unit : N)

Model	End seal	DF	MF
SBI 15	2.0	4.7	3.5
SBI 20	2.5	4.9	3.0
SBI 25	3.0	5.5	3.5
SBI 30	3.9	5.8	3.5
SBI 35	2.5	5.2	3.7
SBI 45	3.4	5.9	4.1

### HT high temperature end plate

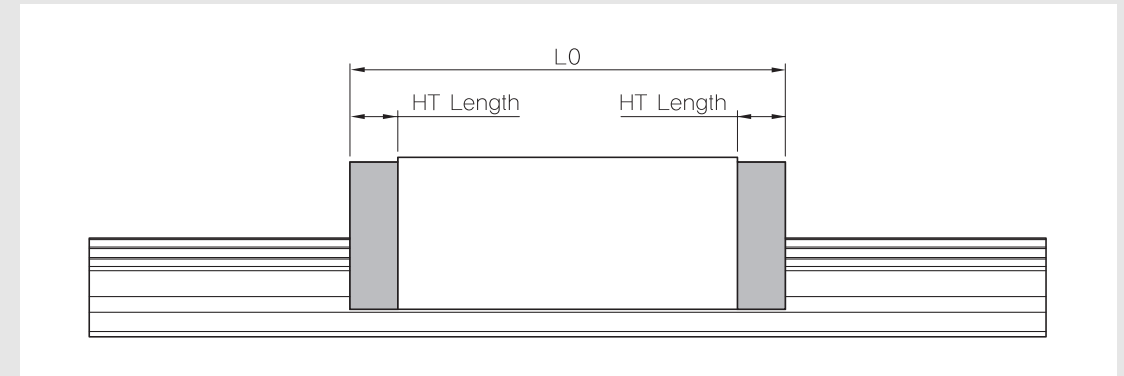

(Unit : mm)

Reference	HT Length	Overall length					
		Applied model	LO	Applied model	LO	Applied model	LO
HT 15A	6.5	SBI 15 V	38.3	SBI 15	62.2	SBI 15L	77.8
HT 20A	8	SBI 20 V	47.1	SBI 20	76.8	SBI 20L	94.4
HT 25A	8	SBI 25 V	50.6	SBI 25	90	SBI 25L	106
HT 30A	10	-	-	SBI 30	105.6	SBI 30L	129.6
HT 35A	11	-	-	SBI 35	122.6	SBI 35L	150.6
HT 45A	13	-	-	SBI 45	140	SBI 45L	172

Ordering example : **SBI25FL - HT - 2 - K1 - 800 - N**

- |                              |               |
|------------------------------|---------------|
| ① Model                      | ④ Preload     |
| ② High temperature end plate | ⑤ Rail length |
| ③ Block quantity             | ⑥ Accuracy    |

※ All plastic components are replace with steel or aluminum in the High Temperature Blocks.

※ Side grease fitting is not available for high temperature end plates

### Grease and nipple specification

#### [Grease]

SBI uses two types of grease according to working conditions. For details, please see the technical data for grease.

### (1) Standard grease fitting (Front grease fitting)

(Unit : mm)

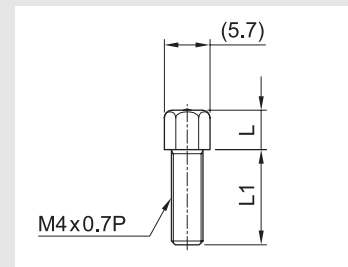

Specification		M4x0.7P		
Applied model	Grease fitting model	Symbol	L	L1
SBI 15	1N	None	7	6
	1D	DD, ZZ	5	9
	1Z	KK	5	11
	1F	DF	5	13

(Unit : mm)

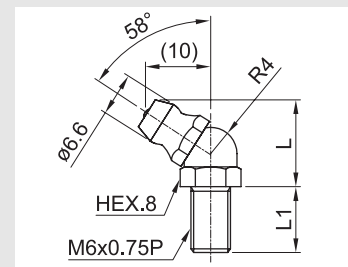

Specification		M6x0.75P, Standard		
Applied model	Grease fitting model	Symbol	L	L1
SBI20~35	IA2N	None	14	8
	IA2D	DD, ZZ	14	10
	IA2Z	KK, DF	14	13
	IA2F	DFDD, DFZZ, DFKK	14	18

(Unit : mm)

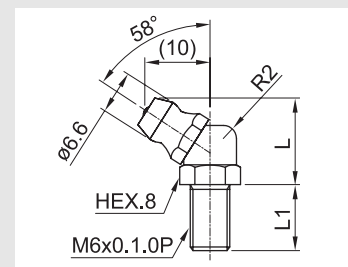

Specification		M6x1.0P, Order made		
Applied model	Grease fitting model	Symbol	L	L1
SBI20~35	IE2N	None	14	8
	IE2D	DD, ZZ	14	10
	IE2Z	KK, DF	14	13
	IE2F	DFDD, DFZZ, DFKK	14	18

(Unit : mm)

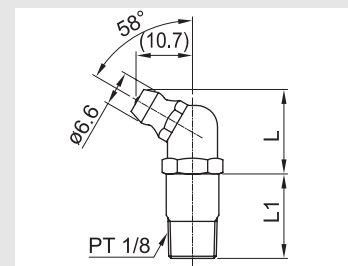

Specification		PT 1/8		
Applied model	Grease fitting model	Symbol	L	L1
SBI45	4N	None	17	13
	4D	DD, KK, ZZ	17	16
	4Z	DF	17	21
	4F	DFDD, DFKK, DFZZ	17	24

\* M6x0.75P is standard grease fitting for SBI20~35 type. If you need M6x1.0P, please contact SBC.

### (2) Side grease fitting

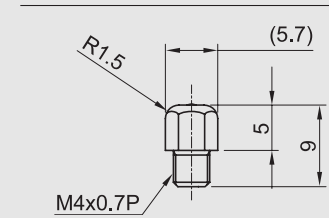

Specification	M4x0.7P
Applied model	SBI 15
Grease fitting model	S1N

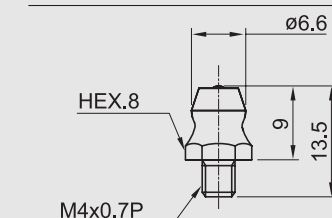

Specification	M4x0.7P
Applied model	SBI 20, 25
Grease fitting model	S2N

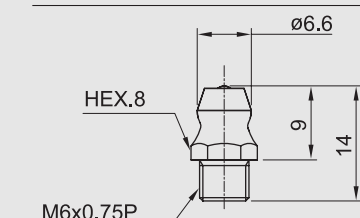

Specification	M6x0.75P
Applied model	SBI 30, 35, 45
Grease fitting model	S3N

### (3) FS nipple connector for side grease fitting (FL, FLL flange type only)

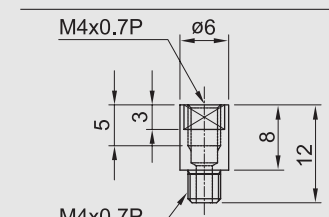

Specification	M4x0.7P
Applied model	SBI 15
Grease fitting model	S1C

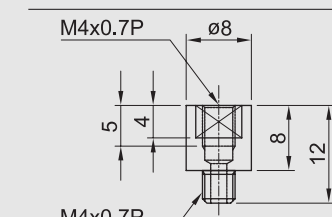

Specification	M4x0.7P
Applied model	SBI 20, 25
Grease fitting model	S2C

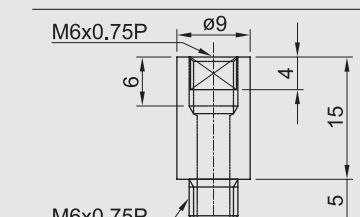

Specification	M6x0.75P
Applied model	SBI 30, 35, 45
Grease fitting model	S3C

### (4) Copper pipe

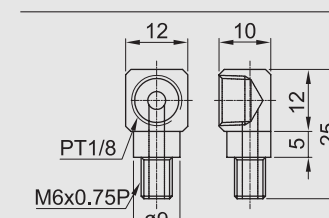

Input size	PT1/8
Output size	M6x0.75P
Applied model	SBI 20
Grease fitting model	S2P

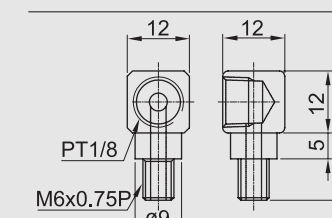

Input size	PT1/8
Output size	M6x0.75P
Applied model	SBI 25, 30, 35
Grease fitting model	S3P

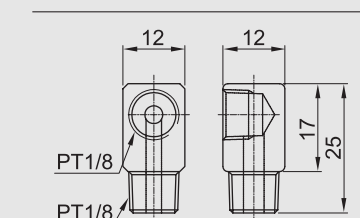

Input size	PT1/8
Output size	PT1/8
Applied model	SBI 45
Grease fitting model	S4P

### Ordering example

**SBI20 FL - N - MF - ZZ - K1**  
 [1] [2] [3] [4] [5] [6]

- [1] Model
- [2] Block type : FL, FLL, FV, SL, SLL, SV, HL, HLL, CL, CLL
- [3] Position of grease fitting : None (front), N (side)
- [4] Container : No symbol (standard), DF (high dust protection), MF (self lubricant)
- [5] Seal : No symbol (standard), DD, ZZ, KK
- [6] Preload : K0, K1, K2, K3

※ "K3" Preload is not available for SBI 15 type

### [Ordering example for rail]

**SBI20 - 1000L - B**  
 [1] [2] [3]

- [1] Model
- [2] Rail length
- [3] Bottom mounting : No symbol (standard), B (bottom mounting rail)

※ If only rail is ordered, N grade is available.

### [Ordering for assembled rail and block]

**SBI20 FL - N - MF - ZZ - 2 - K1 - 800 - N - R - B - II**  
 [1] [2] [3] [4] [5] [6] [7] [8] [9] [10] [11] [12]

- [1] Model
- [2] Block type : FL, FLL, FV, SL, SLL, SV, HL, HLL, CL, CLL
- [3] Position of grease fitting : None (front), N (side)
- [4] Container : No symbol (standard), DF (high dust protection), MF (self lubricant)
- [5] Seal : No symbol (standard), DD, ZZ, KK
- [6] Block quantity on rail
- [7] Preload : K0, K1, K2, K3
- [8] Rail length
- [9] Accuracy : N, H, P
- [10] Surface treatment
- [11] (B) Bottom mounting rail : No symbol (standard)
- [12] Rail : number of rails per axis, 1=I, 2=II... 4=IV etc.

※ We recommend block and rail assembled to be ordered where high-precision and high-rigidity are required.

※ For surface treatment, please mark according to each surface treatment symbol.

※ If special G dimension is required, please mark when you place an order.

※ Please contact SBC for high temperature order.

※ "K3" Preload is not available for SBI 15 type

### Standard and Max. Length of SBI rail

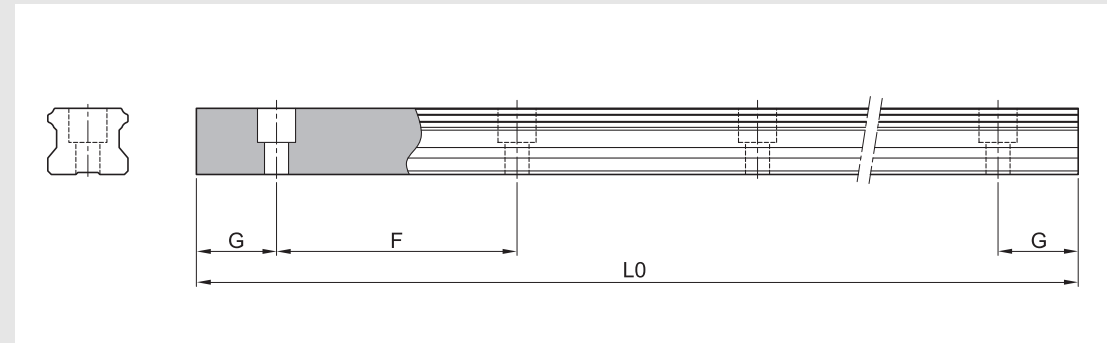

(Unit : mm)

Model number	SBI15	SBI20	SBI25	SBI30	SBI35	SBI45
Standard length	160	220	220	280	280	570
	220	280	280	440	440	885
	280	240	340	600	600	1095
	340	460	460	760	760	1200
	460	640	640	1000	1000	1410
	640	820	820	1240	1240	1620
	820	1000	1000	1480	1480	1830
	1000	1240	1240	1640	1640	2040
	1240	1480	1480	1800	1800	2250
	1480	1600	1600	2040	2040	2460
	1600	1840	1840	2200	2200	2985
	1960	2080	2080	2520	2520	3510
	2200	2200	2200	2840	2840	4000
	2500	2500	2500	3000	3000	-
	2860	2960	2980	3480	3480	-
3000	3520	3520	4000	4000	-	
	4000	4000	-	-	-	
F	60	60	60	80	80	105
G	20	20	20	20	20	22.5
L0(Max length)	3,000	4,000	4,000	4,000	4,000	4,000

\* If the maximum length exceeds this size, butt joints can be supplied.

\* For more information about butt jointing, please refer to the page of safety design.

\* If the G is not standard, please indicate it in the order sheet.

### Bottom mounting rail (SBI-B type)

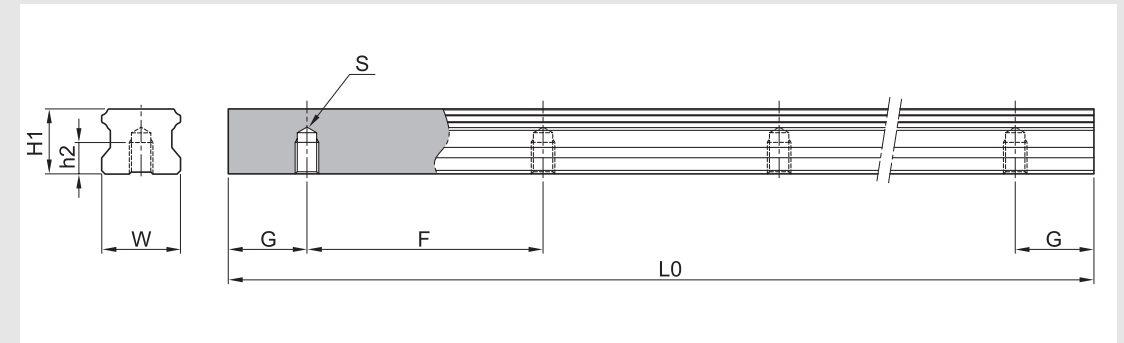

(Unit : mm)

Model number	W1	H1	S	h2	G	F	L0 (Max length)	Weight (kg/m)
SBI 15-B	15	13	M5X0.8	8	20	60	3,000	1.39
SBI 20-B	20	16.5	M6	10	20	60	4,000	2.37
SBI 25-B	23	20	M6	12	20	60	4,000	3.26
SBI 30-B	28	23	M8	15	20	80	4,000	4.63
SBI 35-B	34	26	M8	17	20	80	4,000	6.45
SBI 45-B	45	32	M12	24	22.5	105	4,000	10.49

\* If the maximum length exceeds this size, please contact SBC.

# Linear Rail System

## SBI High-load Linear Rail System

### SBI-FL/FLL

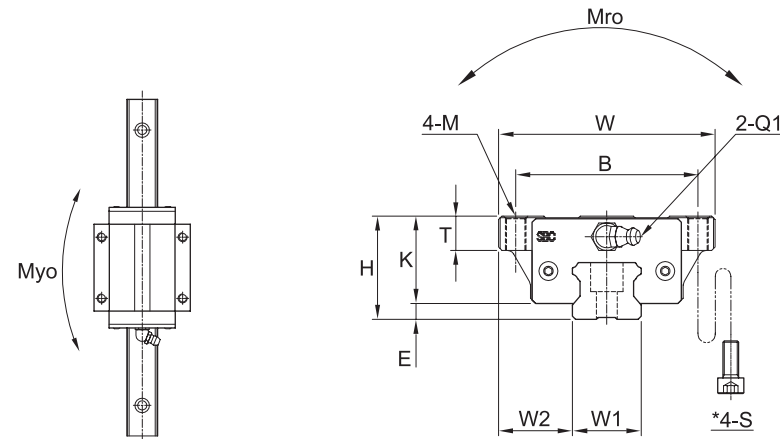

Model	Mounting dimension				Block dimensions												
	H	W	L	E	Mounting tap hole				L1	T	K	Grease fitting					
					B	J	M	*S				T1	N1	T2	N2	Q1	*Q2
SBI15 FL	24	47	63.8	3	38	30	M5	M4	45.2	8.8	21	4.5	5.5	3.8	3.4	M4x0.7	Ø4
SBI15 FLL	24	47	79.4	3	38	30	M5	M4	60.8	8.8	21	4.5	5.5	3.8	3.4	M4x0.7	Ø4
SBI20 FL	30	63	78.8	4.6	53	40	M6	M5	56.8	10	25.4	6	11.7	5.8	5	M6x0.75	Ø4
SBI20 FLL	30	63	96.4	4.6	53	40	M6	M5	74.4	10	25.4	6	11.7	5.8	5	M6x0.75	Ø4
SBI25 FL	36	70	92	5.5	57	45	M8	M6	70	12.5	30.5	6	11.7	5.8	5	M6x0.75	Ø4
SBI25 FLL	36	70	108	5.5	57	45	M8	M6	86	12.5	30.5	6	11.7	5.8	5	M6x0.75	Ø4
SBI30 FL	42	90	107.6	7	72	52	M10	M8	79.6	15.5	35	8.5	11.7	7.8	5	M6x0.75	Ø6
SBI30 FLL	42	90	131.6	7	72	52	M10	M8	103.6	15.5	35	8.5	11.7	7.8	5	M6x0.75	Ø6
SBI35 FL	48	100	124.6	7.5	82	62	M10	M8	94.6	15	40.5	8	11.7	8	6	M6x0.75	Ø6
SBI35 FLL	48	100	152.6	7.5	82	62	M10	M8	122.6	15	40.5	8	11.7	8	6	M6x0.75	Ø6
SBI45 FL	60	120	148	9	100	80	M12	M10	108	18	51	10.5	13.5	9.3	6.5	PT1/8	Ø6
SBI45 FLL	60	120	180	9	100	80	M12	M10	140	18	51	10.5	13.5	9.3	6.5	PT1/8	Ø6

① C (Basic dynamic load rating), Co (Basic static load rating)

② \*S: Bolt size for bottom mounting type of block.

③ \*Q2: The hole of side grease nipple is not made to prevent a foreign substance from going into inside.  
When you order the side grease nipple, we build it by ourselves.

# Linear Rail System

## SBI High-load Linear Rail System

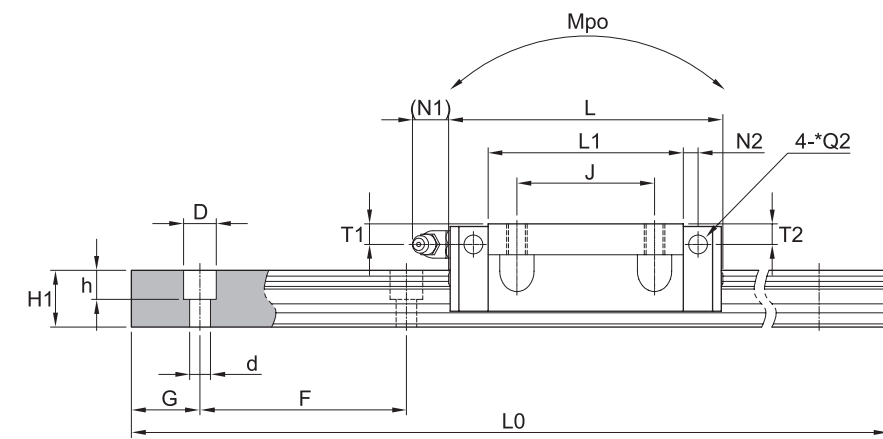

(Unit : mm)

Rail dimension										Basic load rating [kN]		Permissible static moment [kN·m]			Mass	
W1	W2	H1	F	Bolt hole			G	Max length of rail L0	C	Co	Mro	Mpo	Myo	Block [kg]	Rail [kg/m]	
				d	D	h										
15	16	13	60	4.5	7.5	5.5	20	3000	14.1	24.1	0.16	0.17	0.17	0.19	1.3	
15	16	13	60	4.5	7.5	5.5	20	4000	17.1	31.7	0.21	0.29	0.29	0.26	1.3	
20	21.5	16.5	60	6	9.5	8.5	20	4000	22.2	38.2	0.36	0.33	0.33	0.41	2.2	
20	21.5	16.5	60	6	9.5	8.5	20	4000	27.9	50	0.47	0.56	0.56	0.54	2.2	
23	23.5	20	60	7	11	9	20	4000	31.5	52.1	0.56	0.56	0.56	0.69	3	
23	23.5	20	60	7	11	9	20	4000	36.7	64.4	0.69	0.84	0.84	0.85	3	
28	31	23	80	9	14	12	20	4000	42.8	65.4	0.85	0.77	0.77	1.04	4.25	
28	31	23	80	9	14	12	20	4000	51.3	84.7	1.10	1.30	1.30	1.37	4.25	
34	33	26	80	9	14	12	20	4000	59.5	89.1	1.42	1.28	1.28	1.56	6.02	
34	33	26	80	9	14	12	20	4000	71.3	115.3	1.83	2.12	2.12	2.04	6.02	
45	37.5	32	105	14	20	17	22.5	4000	79.2	116.3	2.48	1.90	1.90	2.80	9.77	
45	37.5	32	105	14	20	17	22.5	4000	94.8	150.5	3.21	3.14	3.14	3.69	9.77	

# Linear Rail System

## SBI High-load Linear Rail System

### SBI-SL/SLL

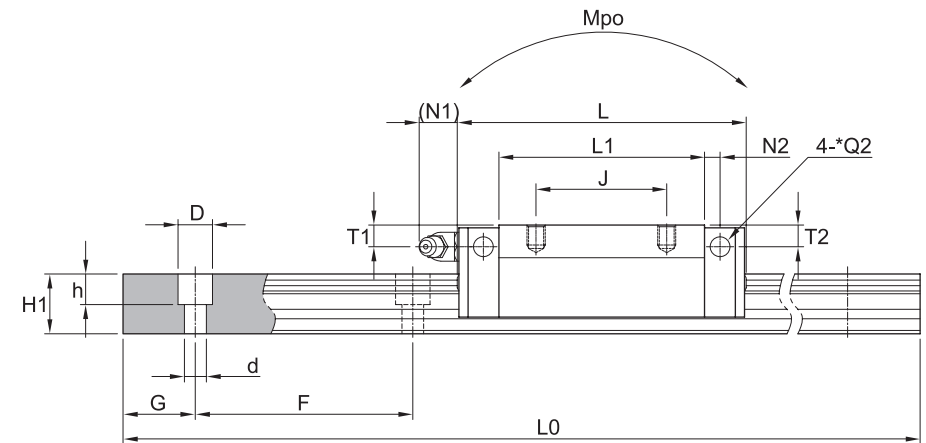
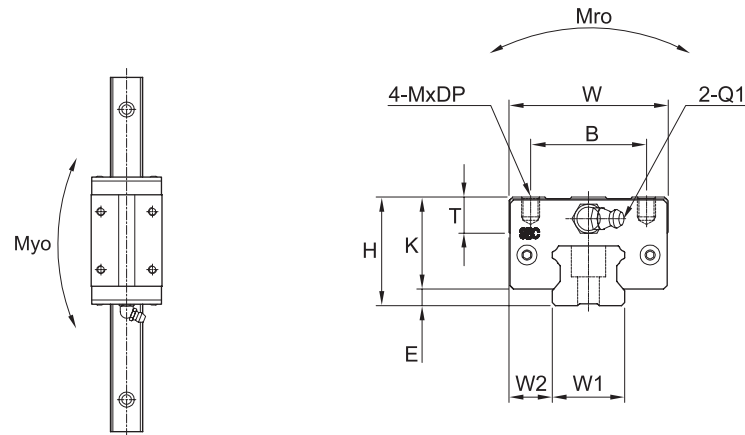

Model	Mounting dimension				Block dimensions												
	H	W	L	E	Mounting tap hole				L1	T	K	Grease fitting					
					B	J	M	DP				T1	N1	T2	N2	Q1	*Q2
SBI15 SL	28	34	63.8	3	26	26	M4	5	45.2	10	25	8.5	5.5	7.8	3.4	M4x0.7	Ø4
SBI15 SLL	28	34	79.4	3	26	34	M4	5	60.8	10	25	8.5	5.5	7.8	3.4	M4x0.7	Ø4
SBI20 SL	30	44	78.8	4.6	32	36	M5	8	56.8	9.8	25.4	6	11.7	5.8	5	M6x0.75	Ø4
SBI20 SLL	30	44	96.4	4.6	32	50	M5	8	74.4	9.8	25.4	6	11.7	5.8	5	M6x0.75	Ø4
SBI25 SL	40	48	92	5.5	35	35	M6	8	70	16	34.5	10	11.7	9.6	5	M6x0.75	Ø4
SBI25 SLL	40	48	108	5.5	35	50	M6	8	86	16	34.5	10	11.7	9.6	5	M6x0.75	Ø4
SBI30 SL	45	60	107.6	7	40	40	M8	10	79.6	12	38	11.5	11.7	10.8	5	M6x0.75	Ø6
SBI30 SLL	45	60	131.6	7	40	60	M8	10	103.6	12	38	11.5	11.7	10.8	5	M6x0.75	Ø6
SBI35 SL	55	70	124.6	7.5	50	50	M8	10	94.6	15	47.5	15	11.7	15	6	M6x0.75	Ø6
SBI35 SLL	55	70	152.6	7.5	50	72	M8	10	122.6	15	47.5	15	11.7	15	6	M6x0.75	Ø6
SBI45 SL	70	86	148	9	60	60	M10	13	108	17	61	20.5	13.5	19.3	6.5	PT1/8	Ø6
SBI45 SLL	70	86	180	9	60	80	M10	13	140	17	61	20.5	13.5	19.3	6.5	PT1/8	Ø6

① C (Basic dynamic load rating), Co (Basic static load rating)

② \*Q2: The hole of side grease nipple is not made to prevent a foreign substance from going into inside. When you order the side grease nipple, we build it by ourselves.

# Linear Rail System

## SBI High-load Linear Rail System

(Unit : mm)

Rail dimension										Basic load rating [kN]		Permissible static moment [kN·m]			Mass	
W1	W2	H1	F	Bolt hole			G	Max length of rail L0	C	Co	Mro	Mpo	Myo	Block [kg]	Rail [kg/m]	
				d	D	h										
15	9.5	13	60	4.5	7.5	5.5	20	3000	14.1	24.1	0.16	0.17	0.17	0.19	1.3	
15	9.5	13	60	4.5	7.5	5.5	20	4000	17.1	31.7	0.21	0.29	0.29	0.26	1.3	
20	12	16.5	60	6	9.5	8.5	20	4000	22.2	38.2	0.36	0.33	0.33	0.41	2.2	
20	12	16.5	60	6	9.5	8.5	20	4000	27.9	50	0.47	0.56	0.56	0.54	2.2	
23	12.5	20	60	7	11	9	20	4000	31.5	52.1	0.56	0.56	0.56	0.69	3	
23	12.5	20	60	7	11	9	20	4000	36.7	64.4	0.69	0.84	0.84	0.85	3	
28	16	23	80	9	14	12	20	4000	42.8	65.4	0.85	0.77	0.77	1.04	4.25	
28	16	23	80	9	14	12	20	4000	51.3	84.7	1.10	1.30	1.30	1.37	4.25	
34	18	26	80	9	14	12	20	4000	59.5	89.1	1.42	1.28	1.28	1.56	6.02	
34	18	26	80	9	14	12	20	4000	71.3	115.3	1.83	2.12	2.12	2.04	6.02	
45	20	32	105	14	20	17	22.5	4000	79.2	116.3	2.48	1.90	1.90	2.80	9.77	
45	20	32	105	14	20	17	22.5	4000	94.8	150.5	3.21	3.14	3.14	3.69	9.77	

# Linear Rail System

## SBI High-load Linear Rail System

### SBI-HL/HLL

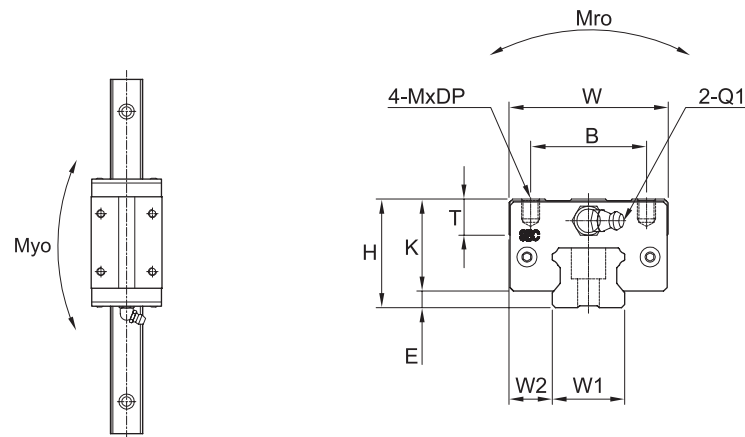

Model	Mounting dimension				Block dimensions												
	H	W	L	E	Mounting tap hole				L1	T	K	Grease fitting					
					B	J	M	DP				T1	N1	T2	N2	Q1	*Q2
SBI15 HL	24	34	63.8	3	26	26	M4	5	45.2	6	21	4.5	5.5	3.8	3.4	M4x0.7	Ø4
SBI15 HLL	24	34	79.4	3	26	34	M4	5	60.8	6	21	4.5	5.5	3.8	3.4	M4x0.7	Ø4
SBI25 HL	36	48	92	5.5	35	35	M6	8	70	12	30.5	6	11.7	5.6	5.5	M6x0.75	Ø4
SBI25 HLL	36	48	108	5.5	35	50	M6	8	86	12	30.5	6	11.7	5.6	5.5	M6x0.75	Ø4
SBI30 HL	42	60	107.6	7	40	40	M8	10	79.6	12	35	8.5	11.7	7.8	5	M6x0.75	Ø6
SBI30 HLL	42	60	131.6	7	40	60	M8	10	103.6	12	35	8.5	11.7	7.8	5	M6x0.75	Ø6
SBI35 HL	48	70	124.6	7.5	50	50	M8	10	94.6	15	40.5	8	11.7	8	6	M6x0.75	Ø6
SBI35 HLL	48	70	152.6	7.5	50	72	M8	10	122.6	15	40.5	8	11.7	8	6	M6x0.75	Ø6
SBI45 HL	60	86	148	9	60	60	M10	13	108	17	51	10.5	13.5	9.3	6.5	PT1/8	Ø6
SBI45 HLL	60	86	180	9	60	80	M10	13	140	17	51	10.5	13.5	9.3	6.5	PT1/8	Ø6

① C (Basic dynamic load rating), Co (Basic static load rating)

② \*Q2: The hole of side grease nipple is not made to prevent a foreign substance from going into inside. When you order the side grease nipple, we build it by ourselves.

# Linear Rail System

## SBI High-load Linear Rail System

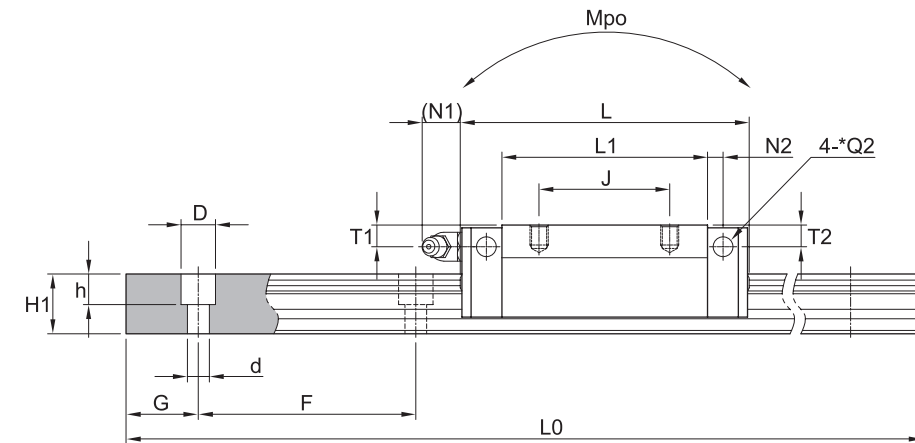

(Unit : mm)

Rail dimension										Basic load rating		Permissible static moment			Mass	
W1	W2	H1	F	Bolt hole			G	Max length of rail L0	C	Co	Mro	Mpo	Myo	Block [kg]	Rail [kg/m]	
				d	D	h										
15	9.5	13	60	4.5	7.5	5.5	20	3000	14.1	24.1	0.16	0.17	0.17	0.19	1.3	
15	9.5	13	60	4.5	7.5	5.5	20	4000	17.1	31.7	0.21	0.29	0.29	0.26	1.3	
23	12.5	20	60	7	11	9	20	4000	31.5	52.1	0.56	0.56	0.56	0.69	3	
23	12.5	20	60	7	11	9	20	4000	36.7	64.4	0.69	0.84	0.84	0.85	3	
28	16	23	80	9	14	12	20	4000	42.8	65.4	0.85	0.77	0.77	1.04	4.25	
28	16	23	80	9	14	12	20	4000	51.3	84.7	1.10	1.30	1.30	1.37	4.25	
34	18	26	80	9	14	12	20	4000	59.5	89.1	1.42	1.28	1.28	1.56	6.02	
34	18	26	80	9	14	12	20	4000	71.3	115.3	1.83	2.12	2.12	2.04	6.02	
45	20	32	105	14	20	17	22.5	4000	79.2	116.3	2.48	1.90	1.90	2.80	9.77	
45	20	32	105	14	20	17	22.5	4000	94.8	150.5	3.21	3.14	3.14	3.69	9.77	

# Linear Rail System

## SBI High-load Linear Rail System

### SBI-CL/CLL

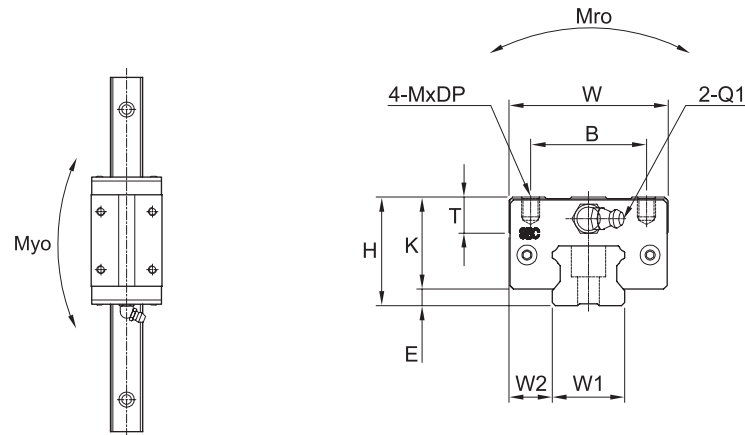

Model	Mounting dimension				Block dimensions												
	H	W	L	E	Mounting tap hole				L1	T	K	Grease fitting					
					B	J	M	DP				T1	N1	T2	N2	Q1	*Q2
SBI20 CL	28	44	78.8	4.6	32	32	M5	5	56.8	7.8	23.4	4.8	11.7	4	5	M6x0.75	M4
SBI20 CLL	28	44	96.4	4.6	32	50	M5	5	74.4	7.8	23.4	4.8	11.7	4	5	M6x0.75	M4
SBI25 CL	33	48	92	5.5	35	35	M6	6	70	9	27.5	5.4	11.7	5.4	5	M6x0.75	M4
SBI25 CLL	33	48	108	5.5	35	50	M6	6	86	9	27.5	5.4	11.7	5.4	5	M6x0.75	M4

① C (Basic dynamic load rating), Co (Basic static load rating)

② \*Q2: The hole of side grease nipple is not made to prevent a foreign substance from going into inside.  
When you order the side grease nipple, we build it by ourselves.

# Linear Rail System

## SBI High-load Linear Rail System

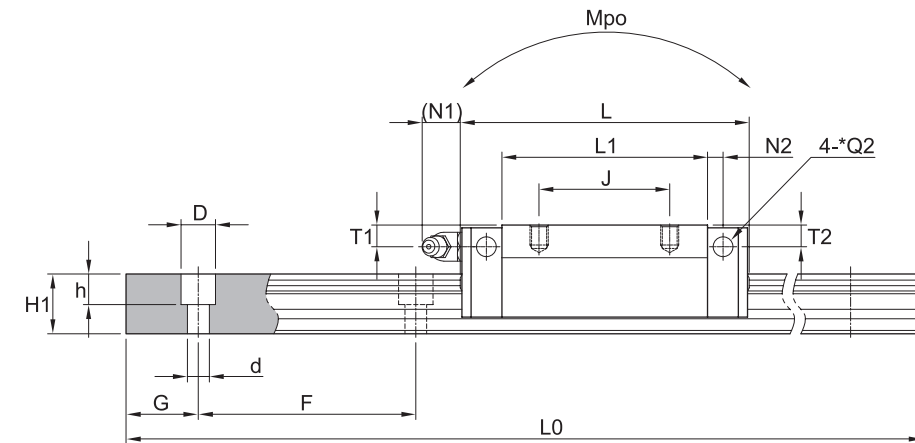

(Unit : mm)

Rail dimension										Basic load rating [kN]		Permissible static moment [kN · m]			Mass	
W1	W2	H1	F	Bolt hole			G	Max length of rail L0	C	Co	Mro	Mpo	Myo	Block [kg]	Rail [kg/m]	
				d	D	h										
20	12	16.5	60	6	9.5	8.5	20	4000	22.2	38.2	0.36	0.33	0.33	0.39	2.2	
20	12	16.5	60	6	9.5	8.5	20	4000	27.9	50	0.47	0.56	0.56	0.52	2.2	
23	12.5	20	60	7	11	9	20	4000	31.5	52.1	0.56	0.56	0.56	0.66	3	
23	12.5	20	60	7	11	9	20	4000	36.7	64.4	0.69	0.84	0.84	0.82	3	

# Linear Rail System

## SBI High-load Linear Rail System

### SBI-FV

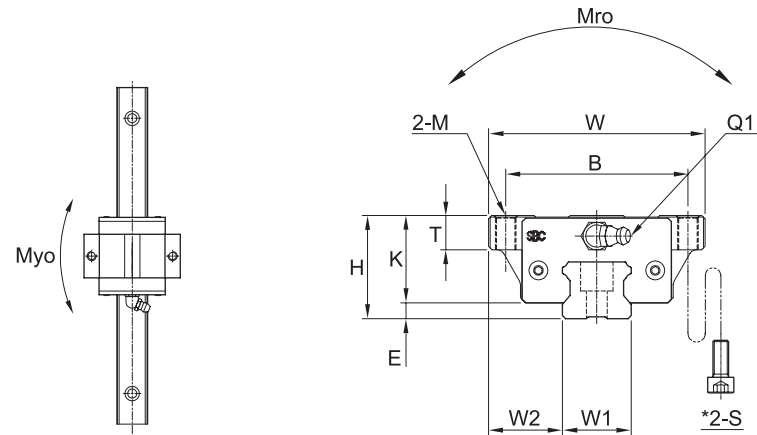

Model	Mounting dimension				Block dimensions											
	H	W	L	E	Mounting tap hole			L1	T	K	Grease fitting					
					B	M	*S				T1	N1	T2	N2	Q1	*Q2
SBI15 FV	24	47	39.9	3	38	M5	M4	21.3	8.8	21	4.5	5.5	3.8	3.4	M4x0.7	Ø4
SBI20 FV	28	63	49.1	4.5	53	M6	M5	27.1	8	23.4	4.8	11.7	4	5	M6x0.75	M4
SBI25 FV	33	70	52.6	5.5	57	M8	M6	30.6	9	27.5	5.4	11.7	5.4	5	M6x0.75	M4

- ① C (Basic dynamic load rating), Co (Basic static load rating)
- ② \*S: Bolt size for bottom mounting type of block.
- ③ \*Q2: The hole of side grease nipple is not made to prevent a foreign substance from going into inside. When you order the side grease nipple, we build it by ourselves.

# Linear Rail System

## SBI High-load Linear Rail System

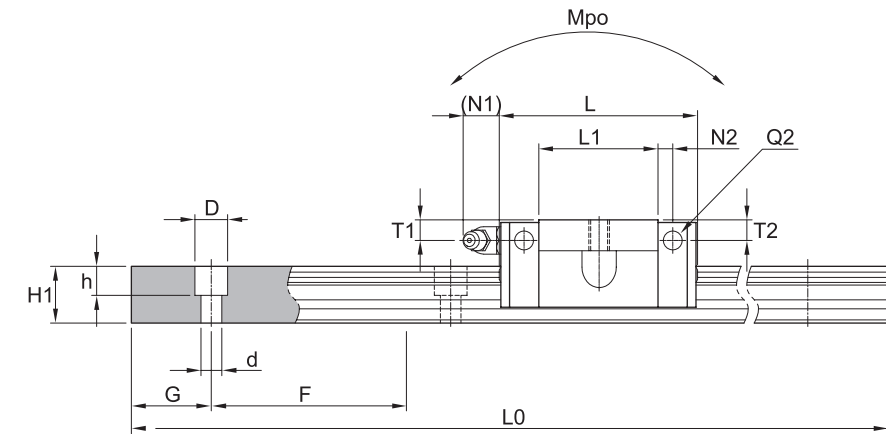

(Unit : mm)

Rail dimension										Basic load rating		Permissible static moment			Mass	
W1	W2	H1	F	Bolt hole			G	Max length of rail L0	C	Co	Mro	Mpo	Myo	Block [kg]	Rail [kg/m]	
				d	D	h										
15	16	13	60	4.5	7.5	5.5	20	3000	5.8	12.8	0.04	0.03	0.03	0.10	1.3	
20	21.5	16.5	60	6	9.5	8.5	20	4000	9.4	20.2	0.12	0.10	0.10	0.24	2.2	
23	23.5	20	60	7	11	9	20	4000	12.4	26.1	0.19	0.17	0.17	0.37	3	

# Linear Rail System

## SBI High-load Linear Rail System

### SBI-SV

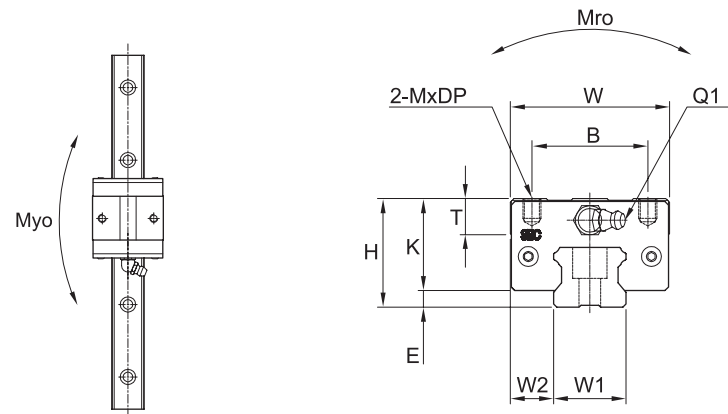

Model	Mounting dimension				Block dimensions												
	H	W	L	E	Mounting tap hole			Grease fitting									
					B	M	DP	L1	T	K	T1	N1	T2	N2	Q1	*Q2	
SBI15 SV	24	34	39.9	3	26	M4	5	21.3	6	21	4.5	5.5	3.8	3.4	M4x0.7	Ø4	
SBI20 SV	28	44	49.1	4.6	32	M5	5	27.1	7.8	23.4	4.8	11.7	4	5	M6x0.75	M4	
SBI25 SV	33	48	52.6	5.5	35	M6	6	30.6	9	27.5	5.4	11.7	5.4	5	M6x0.75	M4	

① C (Basic dynamic load rating), Co (Basic static load rating)

② \*Q2: The hole of side grease nipple is not made to prevent a foreign substance from going into inside.  
When you order the side grease nipple, we build it by ourselves.

# Linear Rail System

## SBI High-load Linear Rail System

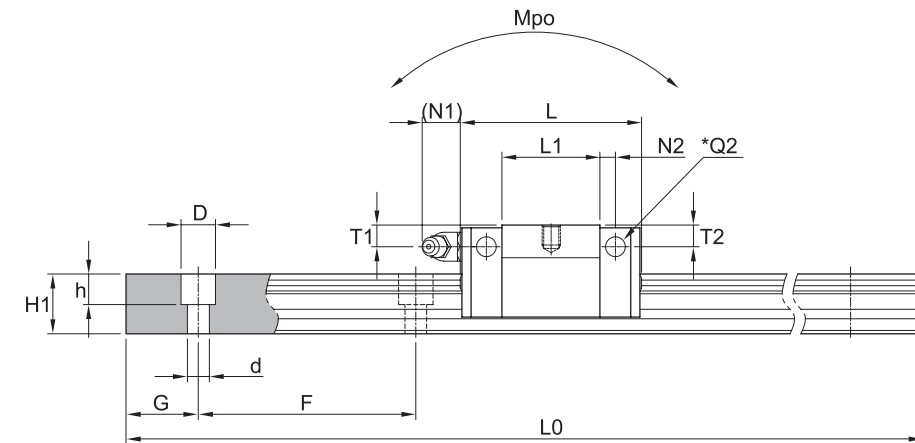

(Unit : mm)

Rail dimension									Basic load rating [kN]		Permissible static moment [kN · m]			Mass	
W1	W2	H1	F	Bolt hole			G	Max length of rail L0	C	Co	Mro	Mpo	Myo	Block [kg]	Rail [kg/m]
				d	D	h									
15	9.5	13	60	4.5	7.5	5.5	20	3000	5.8	12.8	0.04	0.03	0.03	0.10	1.3
20	21.5	16.5	60	6	9.5	8.5	20	4000	9.4	20.2	0.12	0.10	0.10	0.24	2.2
23	23.5	20	60	7	11	9	20	4000	12.4	26.1	0.19	0.17	0.17	0.37	3