

Shaft-Hub-Connections

Shrink Discs • Cone Clamping Elements • Star Discs
Clamping Systems for torque motors • Star Spring Washers



Edition 2019/2020

Table of Contents

Introduction										Page	
Overview										4	
Frictional shaft-hub-connections										6	
Categories of RINGSPANN shaft-hub-connections										7	
Ensured Torques with the RINGSPANN Calculation Method										8	
Online Calculation Tool shaft-hub-connections										9	
Shrink Discs	Max. transmissible torque up to [Nm]	Shaft diameter [mm]	Radial height		Axial width			Clamping element centres the hub to the shaft	No axial displacement of the hub to the shaft during clamping	Actuating device integrated (screws)	Page
			flat	standard	short	medium	long				
Design and Function of Shrink Discs										10	
RLK 608	4 225 000	30 - 620		●		●		●	●	●	12
RLK 606	36 200	24 - 155		●		●		●	●	●	16
Covers for Shrink Discs RLK 608 and RLK 606										19	
RLK 603	1 460 000	14 - 500		●		●		●	●	●	20
RLK 603 S	156 100	14 - 190		●		●		●	●	●	24
RLK 603 K	23 000	24 - 175		●		●		●	●	●	28
Technical Points for Shrink Discs										31	
Cone Clamping Elements	Max. transmissible torque up to [Nm]	Shaft diameter [mm]	Radial height		Axial width			Clamping element centres the hub to the shaft	No axial displacement of the hub to the shaft during clamping	Actuating device integrated (screws)	Page
			flat	standard	short	medium	long				
Design and Function of Cone Clamping Elements										32	
Hub Width and Hub Outer Diameter										33	
RLK 110	18 000	6 - 120	●				●	●	●	●	34
RLK 110 K	2 800	19 - 60	●				●	●	●	●	36
RLK 130	70 000	20 - 180		●		●		●		●	38
RLK 131	43 000	20 - 180		●		●		●	●	●	40
RLK 132	83 500	20 - 200		●	●			●		●	42
RLK 133	51 500	20 - 200		●	●			●	●	●	44
RLK 133 TC	567 500	70 - 520		●	●			●	●	●	46
RLK 136 TC	994 500	70 - 600		●	●			●	●	●	48
RLK 200	428 500	20 - 400		●	●			●	●	●	50
RLK 250	1 050	15 - 70	●		●			●		●	52
RLK 250 L	1 500	15 - 60	●				●	●		●	54
RLK 300	27 393	10 - 200	●		●						56
RLK 350	2 200	5 - 50		●		●		●		●	60
RLK 402	414 500	25 - 300		●			●	●	●	●	62
RLK 402 TC	1 701 000	70 - 600		●			●	●	●	●	64
RLK 404	1 206 000	70 - 600		●			●	●	●	●	66
RLK 404 TC	1 206 000	70 - 600		●			●	●	●	●	68
Trantorque Mini - metric	140	3 - 16	●				●	●		●	70
Trantorque OE - metric	658	17 - 35	●				●	●		●	72
Technical Points for Cone Clamping Elements										74	

Star Discs		Max. transmissible torque up to	Shaft diameter	Radial height		Axial width			Clamping element centres the hub to the shaft	No axial displacement of the hub to the shaft during clamping	Actuating device integrated (screws)	Page
		[Nm]	[mm]	flat	standard	short	medium	long				
Design and Function of Star Discs											76	
Clamping Connections with Star Discs											77	
Star Discs		5 200*	4 - 100		●	●						78
Technical Points for Star Discs											80	
Clamping Systems for torque motors		Max. transmissible torque up to	Shaft diameter	Radial height		Axial width			Clamping element centres the hub to the shaft	No axial displacement of the hub to the shaft during clamping	Actuating device integrated (screws)	Page
		[Nm]	[mm]	flat	standard	short	medium	long				
Clamping Systems for torque motors											82	
RTM 601	Customer-specific				●		●		●	●	●	83
RTM 607	60 - 125	60 - 125			●			●	●	●	●	84
RTM 608.1 and RTM 608.2	Customer-specific				●			●	●	●	●	86
RTM 134.1 and RTM 134.2	Customer-specific				●			●	●	●	●	87
Star Spring Washers											Page	
Star Spring Washers as Ball Bearing Compensating Discs											88	

* For a pack of 16 Star Discs.

Issue 10/2019 • Technical details subject to change without notice.

Overview

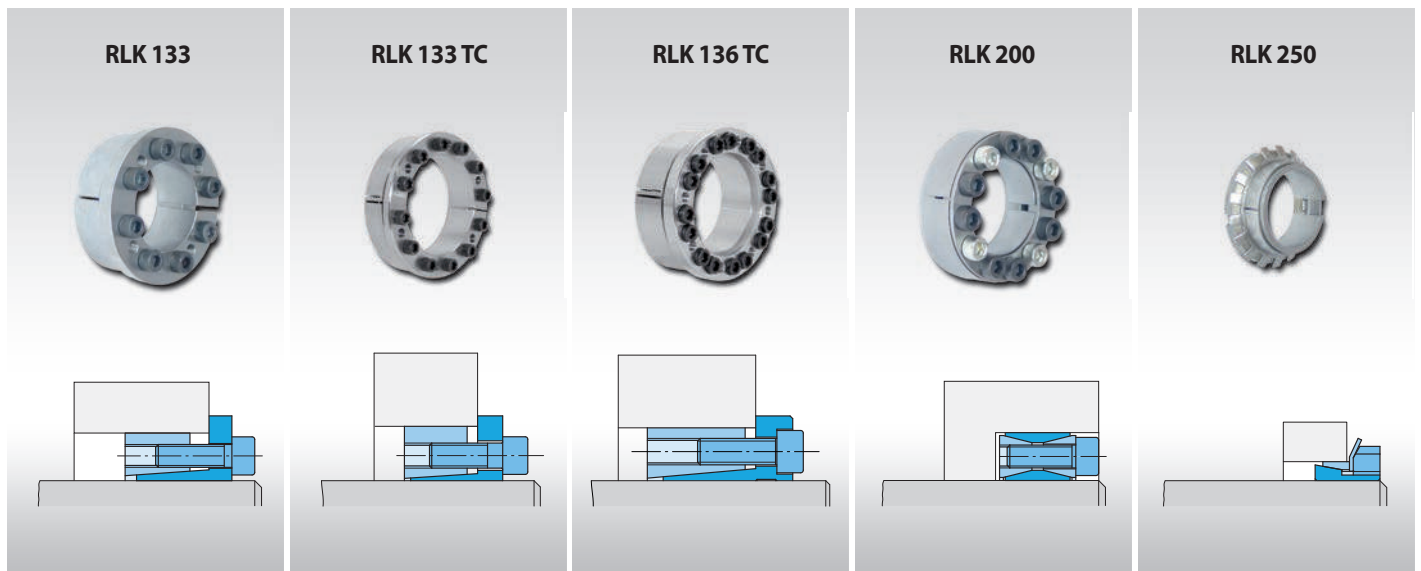
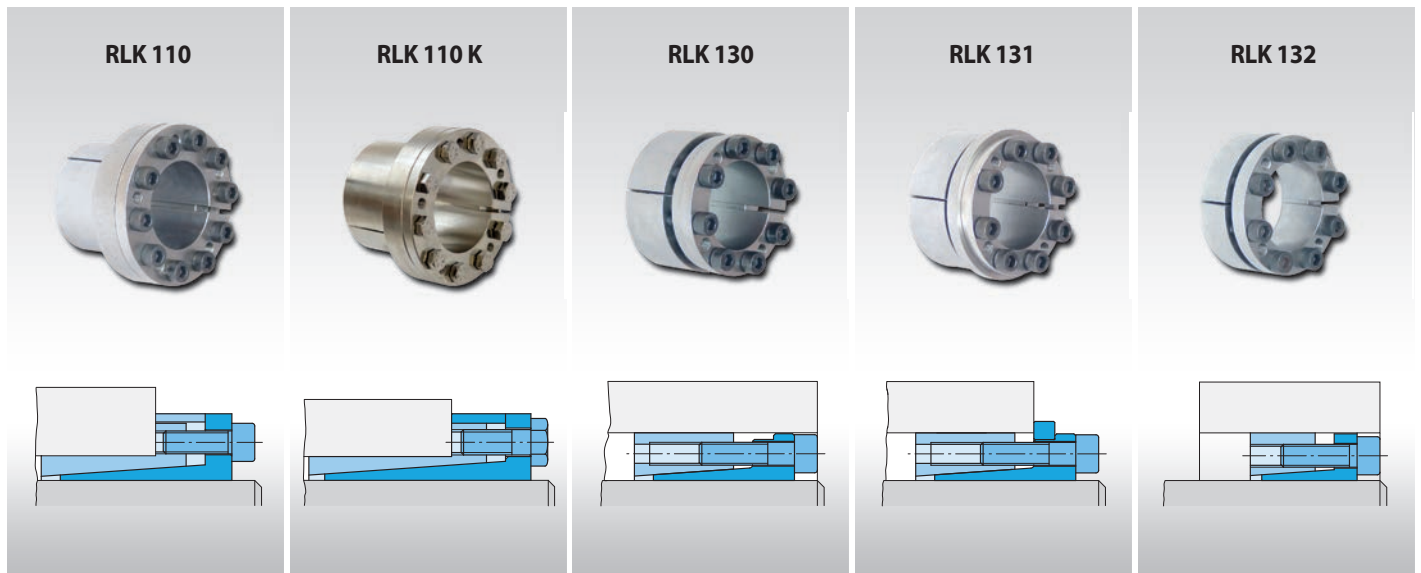
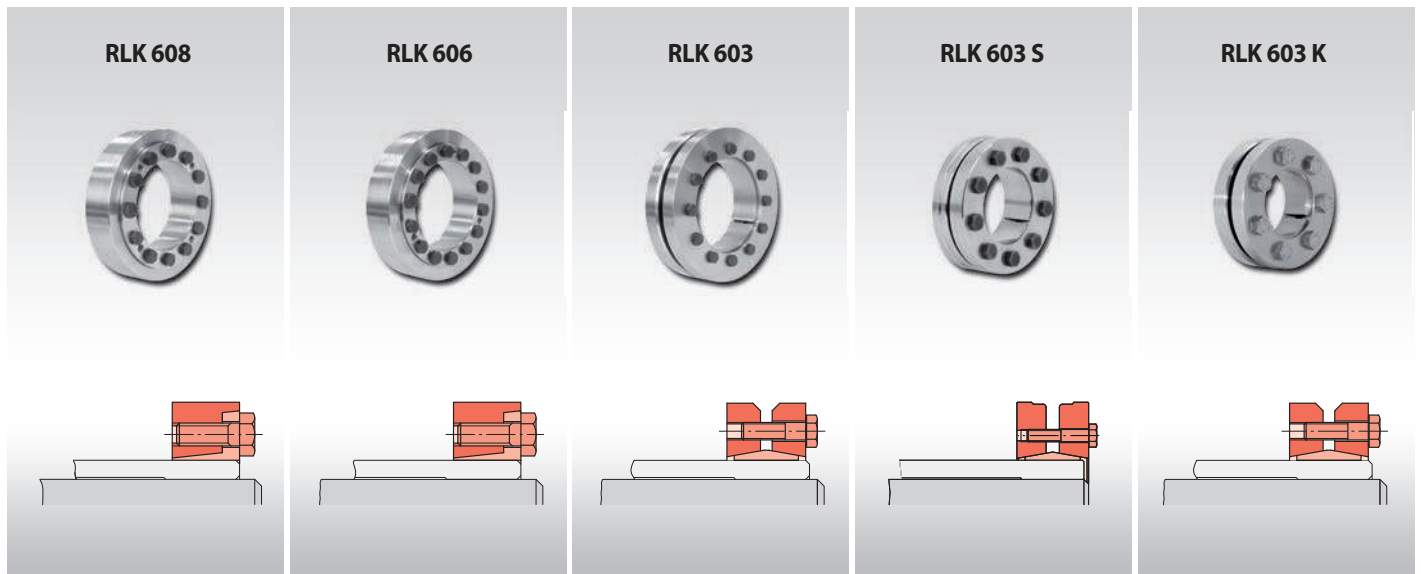

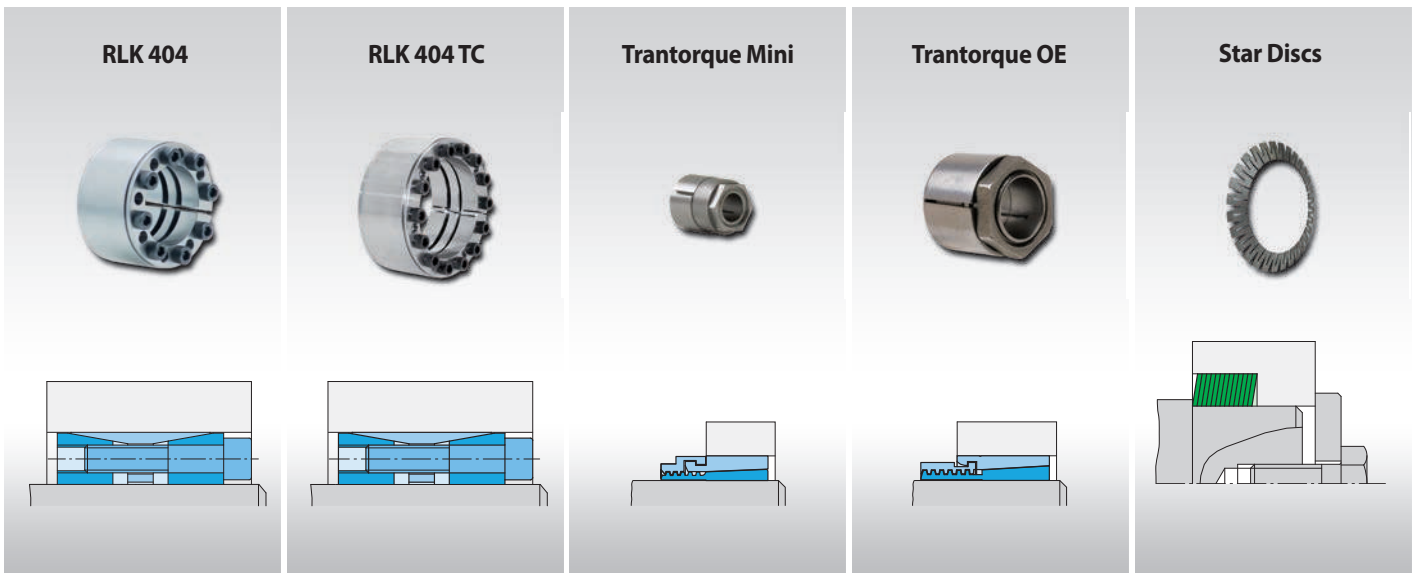
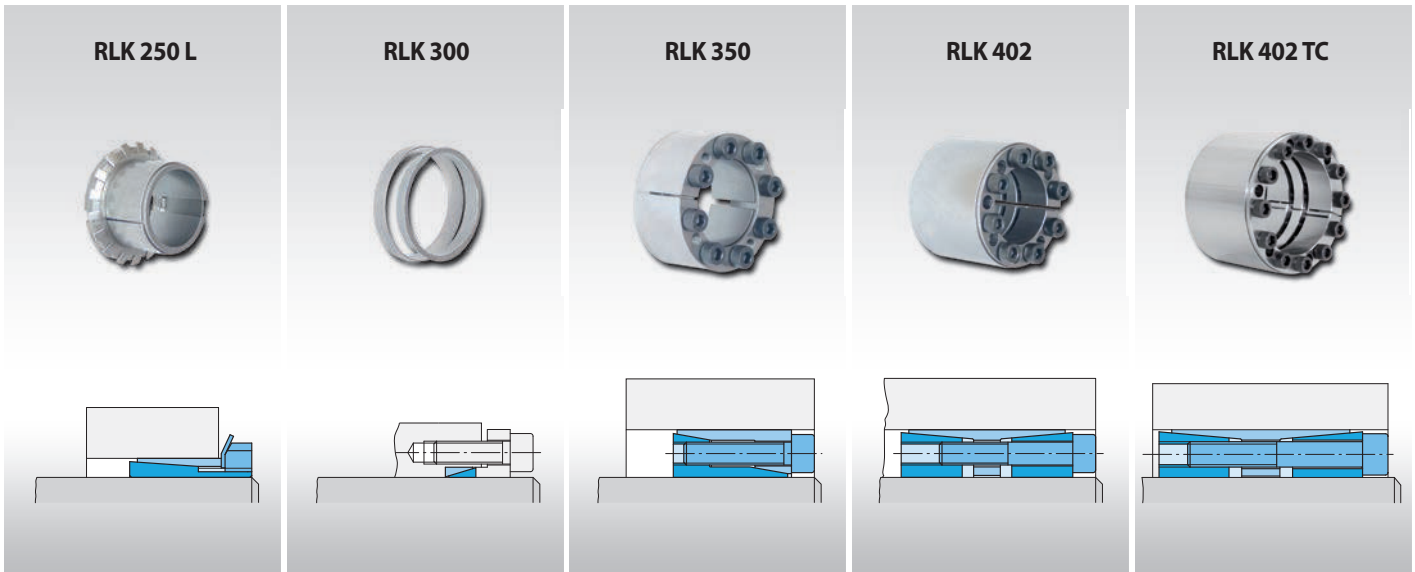

Why frictional shaft-hub-connections?

Frictional shaft-hub-connections are standard machine elements used to connect shafts and hubs. They are capable of transmitting torque, axial forces, radial forces and bending moments.

Shrink Discs and Cone Clamping Elements

Among the frictional shaft-hub-connections Shrink Discs and Cone Clamping Elements take an important position. By tightening clamping screws conical surfaces are pulled together generating radial forces; these forces provide the required frictional connection between the parts involved in the transmission of torques or forces.

Shrink Discs and Cone Clamping Elements are capable of transmitting much higher torques than conventional positive connections with keyways. The shafts can be designed smaller and shorter. The relationships between shaft diameter and shaft length are illustrated in the example shown in figure 6-1. In this comparison, the same torque is transmitted via a Cone Clamping Element (upper half of the figure) and via a keyway connection (lower half of the figure). The Cone Clamping Element design offers a much more compact and cost effective solution.

Star Discs

A special category of frictional shaft-hub-connection is the RINGSPANN Star Disc. Connections using Star Discs are ideally suited to applications requiring repeated adjustment with adjustment devices in a short overall length.

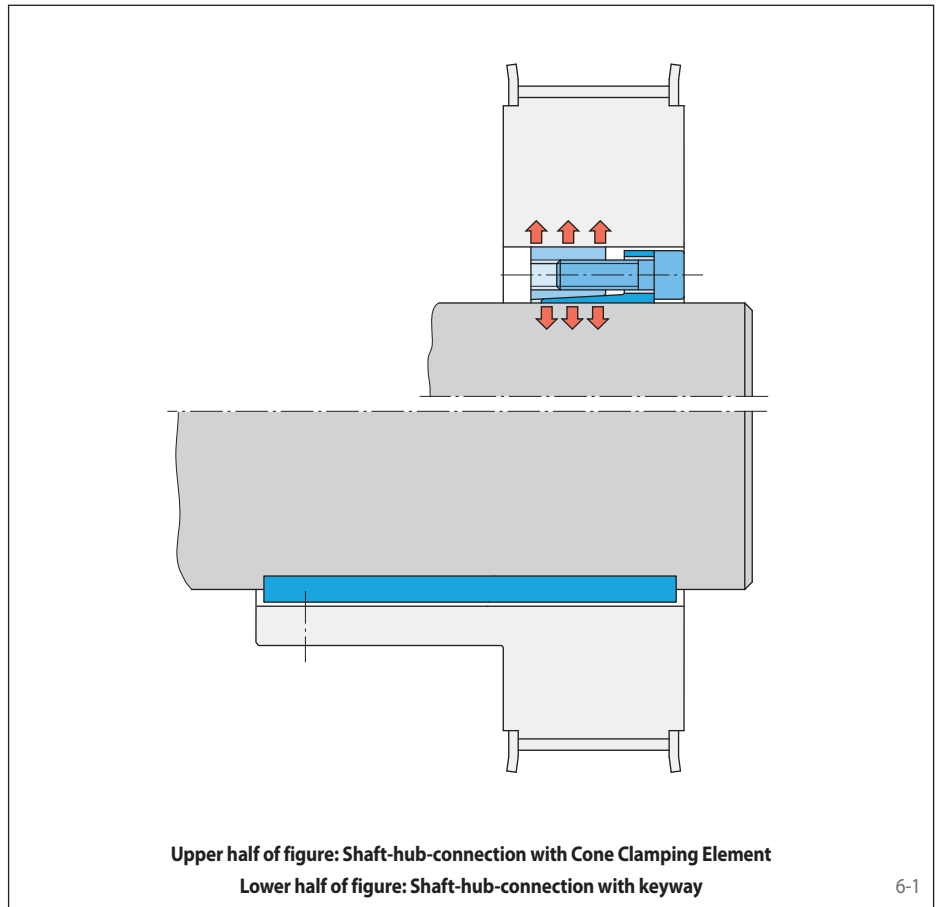

Clamping Systems for torque motors

Both complete torque motors and integrated torque motors can be connected by friction to machine shafts with RINGSPANN torque motor clamping systems. In addition to secure, backlash free torque transmission, these systems also ensure precise centring of the torque motor on the machine shaft.

Star Spring Washers as Ball Bearing Compensating Discs

RINGSPANN Star Spring Washers are particularly light spring elements with linear or non linear spring characteristic. They are suitable for application as pressure elements in precision machines and as pressure springs for taking up free movement, and for reducing noise in ball bearings.

Advantages of Frictional shaft-hub-connections

- Backlash free connections
- Ideal for reversing operation
- Simultaneous transmission of torque and axial force
- Easy alignment of hub to shaft
- Compact solutions due to high power density
- Reduced costs due to simple shaft and hub geometry
- Connections can be released even after long operation time

Categories of RINGSPANN shaft-hub-connections

Shrink Discs

Shrink Discs are external clamping connections for the backlash free fastening of hollow shafts or hubs to shafts. By tightening clamping screws conical surfaces are pulled together generating radial forces; these forces press the hollow shaft onto the shaft. Torques or axial forces can be transmitted frictionally from the hollow shaft to the shaft. The Shrink Disc itself is not involved in the transmission of torques or axial forces. The radial clamping forces which act through the circumference of the hollow shaft also ensure an optimum centring to the shaft.

Shrink Discs are used, for example, to fasten machine shafts to gearboxes with hollow-shafts.

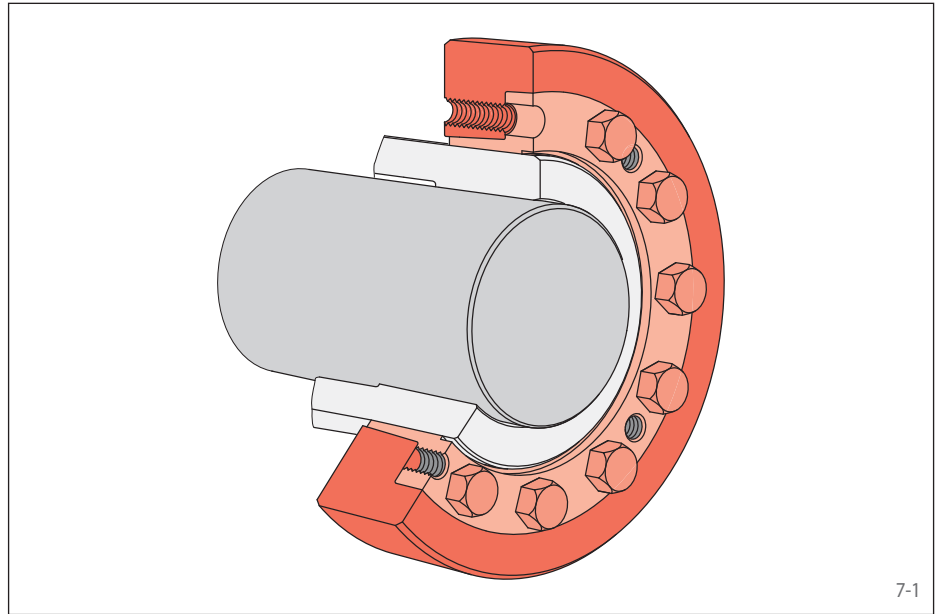

7-1

Cone Clamping Elements

Cone Clamping Elements are internal clamping connections for backlash free fastening of hubs on shafts. By tightening clamping screws conical surfaces are pulled together generating radial forces; these forces create a frictional connection between the Cone Clamping Element and the shaft as well as the hub. Torques or axial forces can be transmitted from the shaft via the Cone Clamping Element to the hub.

Cone Clamping Elements are used, for example to fasten sprockets, flywheels, levers, pulleys, brake discs or conveyor-belt drums.

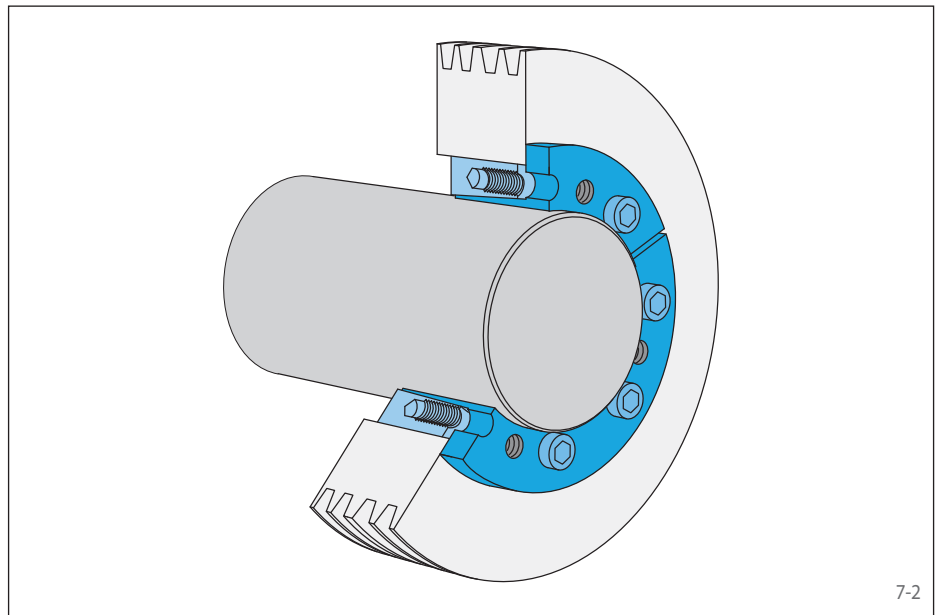

7-2

Star Discs

Star Discs are flat-bevelled rings which are slotted on the outside and inside. An external axial actuating force is translated by the Star Disc into a much higher radial force. This force creates a frictional connection between the Star Disc and the shaft as well as the hub. Generally, Star Discs are installed in a multiple arrangement as a disc pack. This makes it possible to adjust the transmissible torque to the requirements of the specific application.

Shaft-hub-connections with Star Discs are used wherever frequent clamping and release are required, for example in adjustment devices.

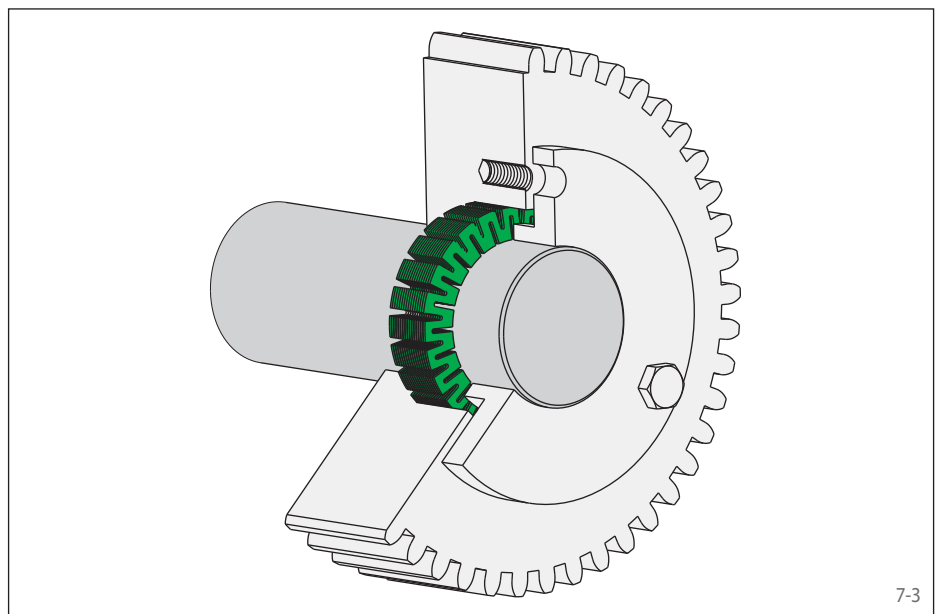

7-3

Ensured Torques with the RINGSPANN Calculation Method

The RINGSPANN calculation method takes into account the friction-coefficient fluctuations which naturally occur in all screw connections. The transmissible torques or axial forces listed in this catalogue are based on friction-coefficient fluctuations in accordance with VDI Guideline 2230 and are minimum values. This ensures a reliable selection of the shaft-hub-connection.

In contrast, torques shown in catalogues issued by various other manufacturers are based on simplified calculation methods. These catalogue values are often comparatively higher, but are subject to the friction-coefficient fluctuations described below and thus do not represent reliable minimum values for customers and users.

In most frictional shaft-hub-connections, the frictional connection is created by torque-controlled tightening of screws. These axially positioned screws are tightened to a specified screw tightening torque. On the basis of the determined preload forces and the transmission ratio of the conical angles, the radial forces between the clamping element and the shaft or hub are calculated by taking into account friction losses. With these radial forces and the friction coefficients between the components, the transmissible torques or axial forces can be calculated.

The determination of the correct actual preload force in a given application is of prime importance. Simple calculation methods are based on an assumed preload force, from which the pressures (and thus the component stress factors) as well as the transmissible torques or axial forces are calculated. The use of such calculation methods is dangerous, as friction-coefficient fluctuations lead to actual preload forces that are higher or lower than assumed. If the actual preload forces are higher, also higher torques may be transmitted, but then the component stress factors are also higher than calculated, which can cause component damage (e.g. to the hub) in extreme cases. In the opposite case, when the preload forces are lower than assumed, the calculated torques or axial forces may not be transmitted. Consequently, the connection slips.

The RINGSPANN calculation method ensures that such errors in the dimensioning of shaft-hub-connections are avoided. This is achieved by using a method that has been tested and proven over many years, according to which the real friction coefficient μ_k in the contact area

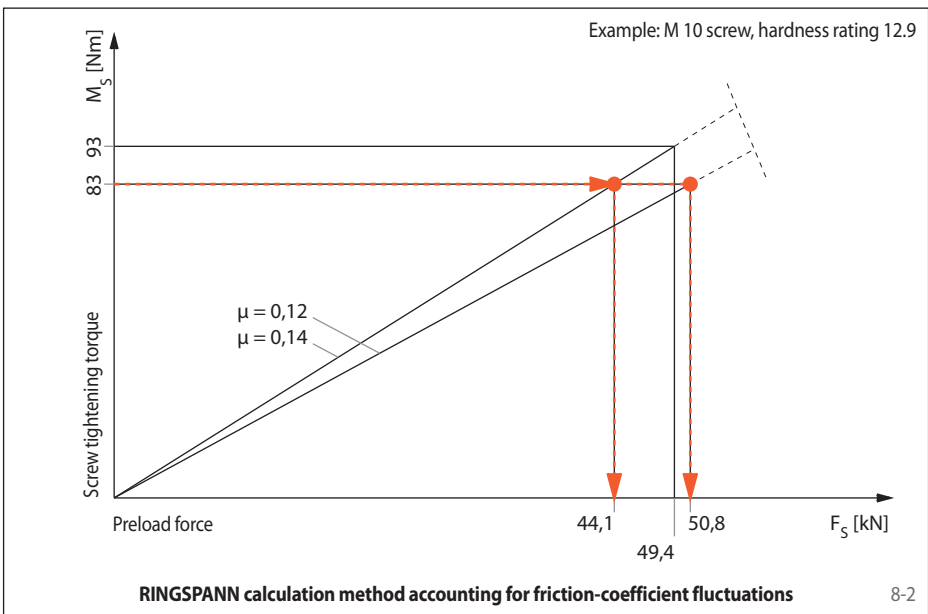
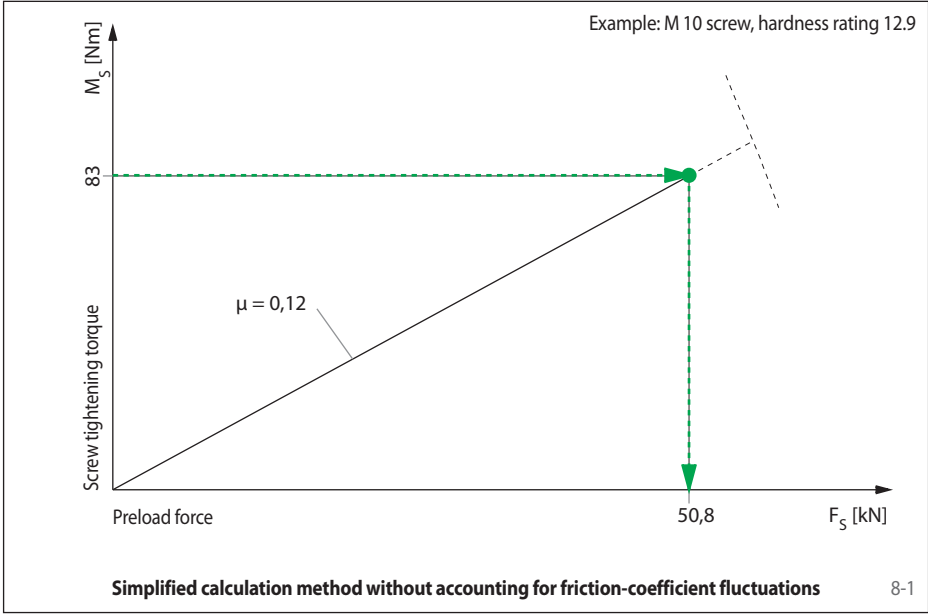

under the head of the screw and μ_G in the screw threading lie between 0,12 and 0,14. This conforms to current engineering standards as described in VDI Guidelines 2230. The RINGSPANN method for calculating preload forces is described below using the example of a M 10 screw with a hardness rating of 12.9.

As the actual friction coefficient in a given case is unknown, the screw tightening torque M_S must correspond to the lowest friction coefficient of $\mu = 0,12$ ($M_S = 83$ Nm) according to the RINGSPANN calculation method. If a higher tightening torque is used, the screw could be overloaded.

If the actual friction coefficient is $\mu = 0,14$, then the preload force $F_S = 50,8$ kN will not be achieved with a screw tightening torque of

$M_S = 83$ Nm. The preload force will be only $F_S = 44,1$ kN, as shown in figure 8-2. The transmissible torque is then calculated on the basis of a preload force of $F_S = 44,1$ kN, whereas the component stress factors in the hub are calculated on the basis of a preload force of $F_S = 50,8$ kN.

The new RINGSPANN Calculation Tool has been developed to work out the right and time-efficient dimensioning of an optimal shaft-hub-connection.

Whether a Cone Clamping Element or a Shrink Disc, reliable results concerning the necessary hub dimensions and bearing pressures can be determined within a few minutes, as well as the transmissible torques and axial forces for different strengths, torques and numbers of screws. This means that any oversizing or undersizing of the elements can be avoided and a cost-optimised solution found for the application in question.

The use of the tools is intuitively designed and the calculation results are available after just a few steps. A suitable product is first selected based on certain criteria, such as for example the dimensions or the torque to be transmitted. The information related to the selected product is then offered for download as a pdf file as well as the appropriate CAD models.

After that, a customised calculation is carried out and the result is represented in a clear lay-

out. Now the torques and axial forces can even be calculated while torque and axial force are transmitted at the same time.

A special function offered by the Calculation Tool is that it checks the torque to be transmitted while taking the axial forces that occur into account, as well as any additional bending moments such as those which can occur in the pulleys of belt conveyor systems.

The Calculation Tool is thus a functional tool for reliably checking a RINGSPANN shaft-hub-connection for your application.

You will find an easy-to-follow video tutorial on our website at: ringspann.com/en/downloads/videos

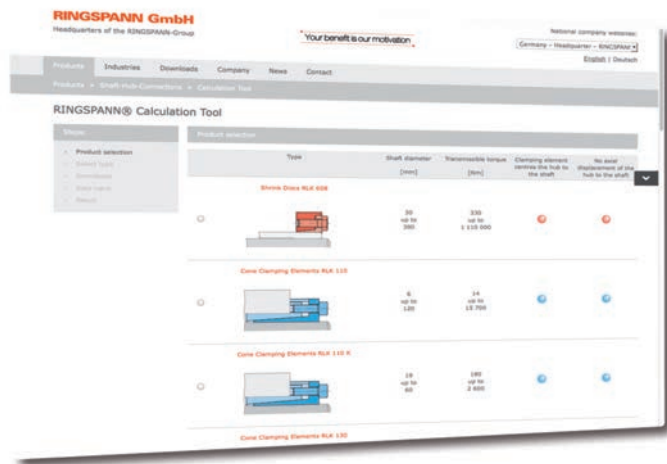

Shrink Discs



Cone Clamping Elements



Overview of the functions of the Calculation Tool:

- Selection of series and clamping set sizes
- Downloading of relevant product information
- Downloading of CAD models
- Calculation of transmissible torques and axial forces for customized shaft diameters while taking tightening torques, the number of clamping screws, yield strengths, materials and tolerances into account
- Calculation of the transmissible torques and axial forces while at the same time transmitting torque and axial force
- Calculation of transmissible torques with bending moments occurring simultaneously
- Calculation of the required outside diameter of the hub
- Calculation the necessary hub width

Two-part Shrink Discs

Design and Function

Two-part shrink discs consist of an outer stepped conical ring, and an inner stepped conical bush, as well as a number of clamping screws (see Figure 10-1).

The stepped conical ring is pulled onto the stepped conical bush by tightening the clamping screws. A radial clamping force is generated by the conical surfaces, which is independent of the friction coefficients at the screws and conical surfaces. The radial clamping force presses the hollow shaft onto the shaft and creates a frictional connection at the contact surfaces between the shaft and the hollow shaft. Thereby, torque and/or axial force can be transmitted between the shaft and the hollow shaft.

During the clamping process, the position of the stepped conical bush relative to the hollow shaft remains unchanged. The connection is released by tightening clamping screws in the threaded bores for the jacking screws.

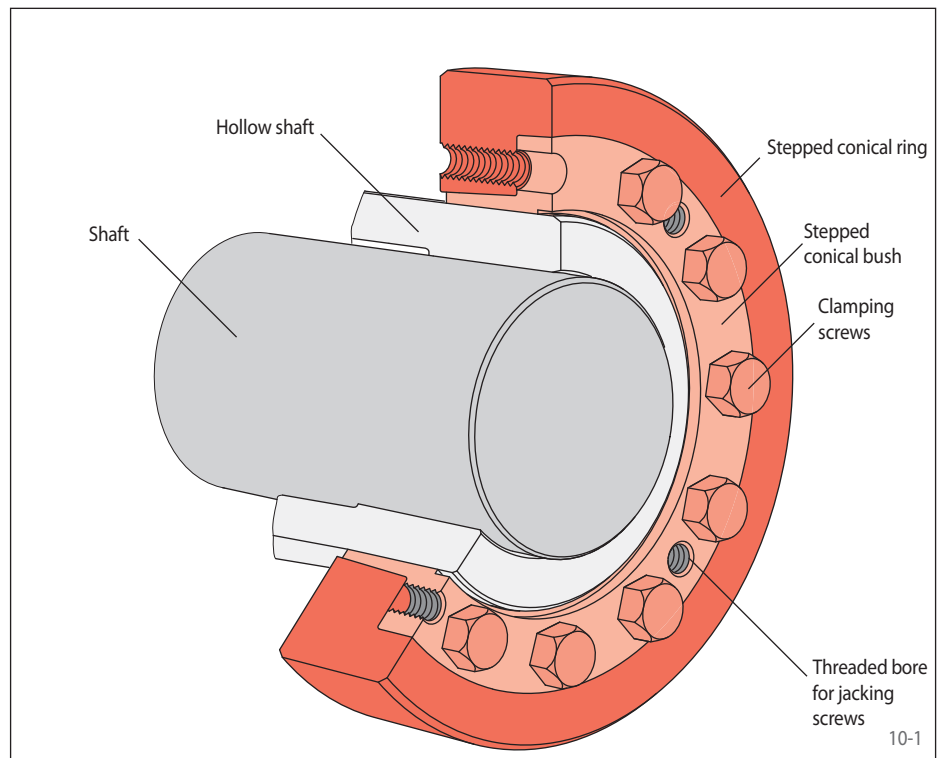

Distance-controlled assembly

The clamping screws are tightened uniformly in a clockwise sequence until the front face of the stepped conical ring is flush with the front face of the stepped conical bush (see figure 10-2).

Once this assembly state is reached, the torque or axial force values shown in the tables can be reliably transmitted between the hollow shaft and the shaft.

Insufficient or missing lubrication of the conical surfaces as might happen during servicing will make the assembly procedure impossible to complete.

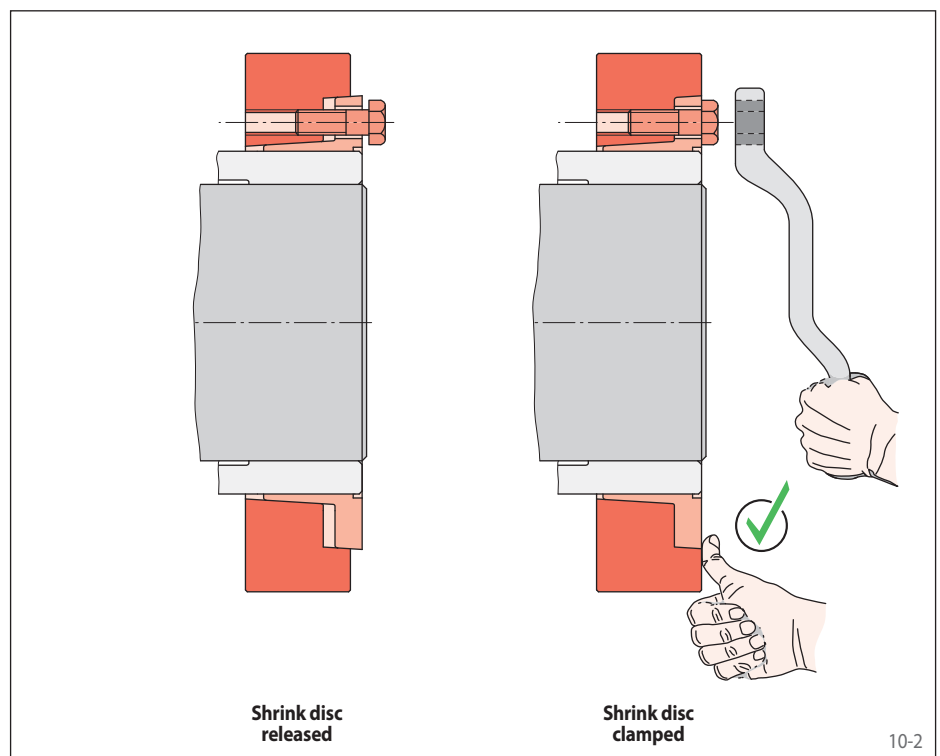

Characteristics

- Easy, quick assembly by tightening clamping screws without a torque wrench
- Modern design with high power density
- Distance-controlled assembly ensures guaranteed transmissible torques
- Enclosed design, therefore impervious to dirt
- True running even at high speeds

Three-part Shrink Discs

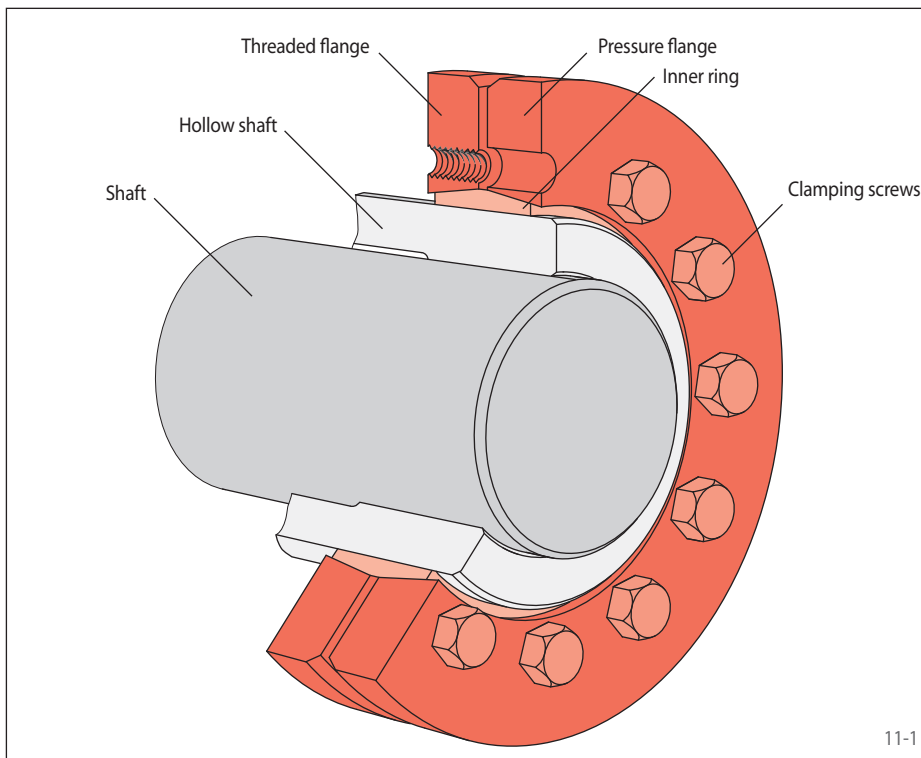

Design and Function

Three-part shrink discs consist of a threaded flange, a pressure flange, a slotted inner ring and a number of clamping screws (see figure 11-1).

The threaded flange and the pressure flange are pulled together over the inner ring by tightening the clamping screws. A radial clamping force is generated by the conical surfaces which is dependent on the friction coefficients at the screws and conical surfaces. The radial clamping force presses the hollow shaft onto the shaft and creates a frictional connection at the contact surfaces between the shaft and the hollow shaft. Thereby, torque and/or axial force can be transmitted between the shaft and the hollow shaft.

During the clamping process, the position of the inner ring relative to the hollow shaft remains unchanged. The connection is released simply by loosening the clamping screws, as the cone angles are self-releasing.

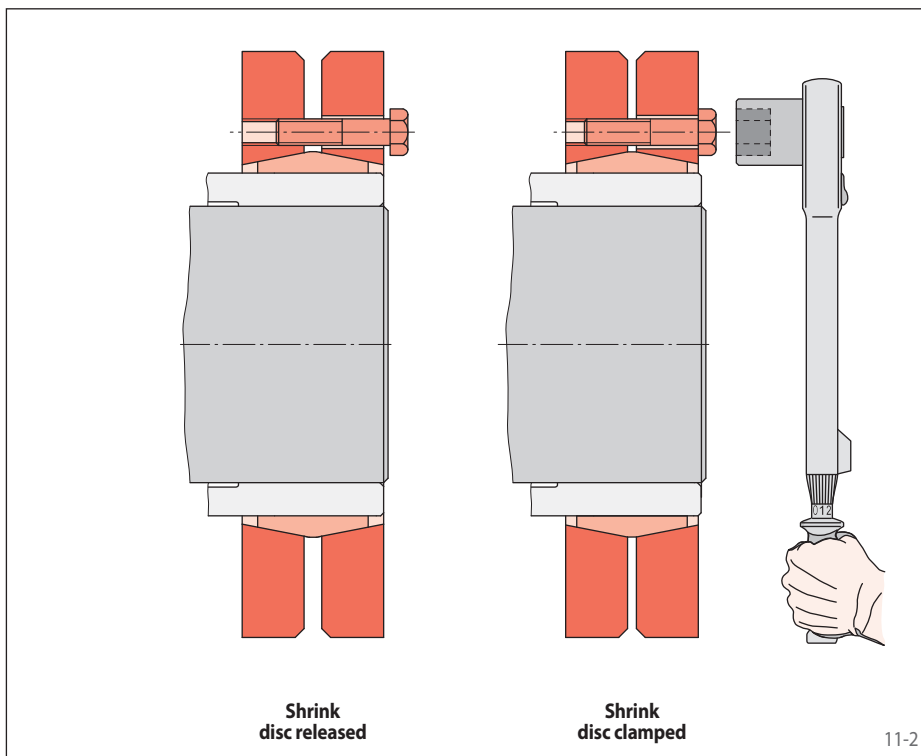

Torque-controlled assembly

The clamping screws are tightened uniformly in a clockwise sequence until the specified torque is achieved (see figure 11-2).

Insufficient or missing lubrication of the conical surfaces as might happen during servicing, results in a reduction of the radial clamping force. The torques or axial forces listed in the tables can no longer be transmitted reliably. This often goes unnoticed as the specified tightening torque was achieved during assembly and the assembly procedure is considered completed.

Characteristics

- Tightening of clamping screws with a torque wrench
- Classical design
- Torque-controlled assembly
- Easy disassembly without jacking screws

two-part design
highest torque capacity

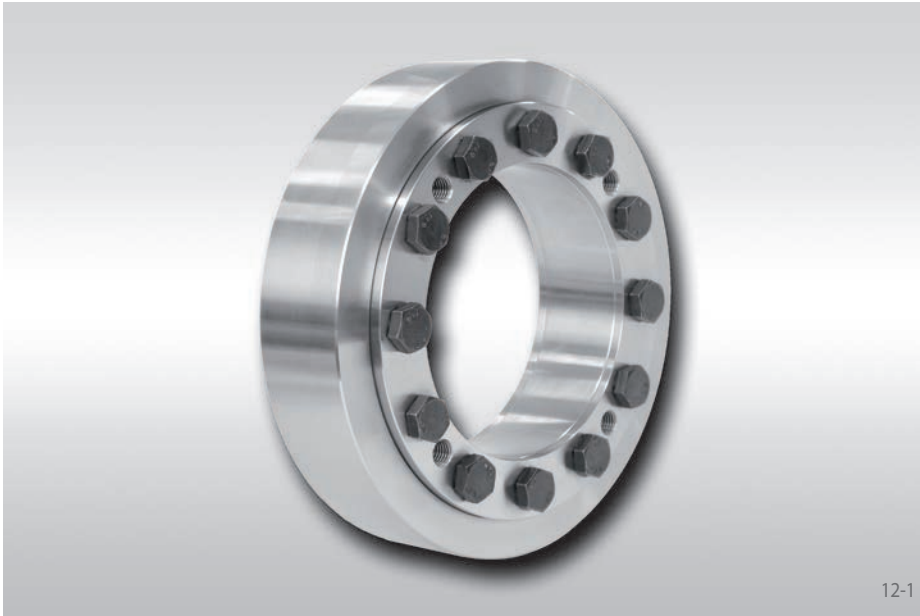

12-1

Features

- Highest torque capacity
- Transmissible torque of 330 Nm up to 4225 000 Nm
- Easy, quick assembly by tightening clamping screws without a torque wrench
- Distance-controlled assembly ensures guaranteed transmissible torques
- Enclosed design, therefore impervious to dirt
- True running even at high speeds
- Centres the hollow shaft or hub to the shaft
- For hollow shafts or hubs with outer diameters of 30 mm up to 620 mm

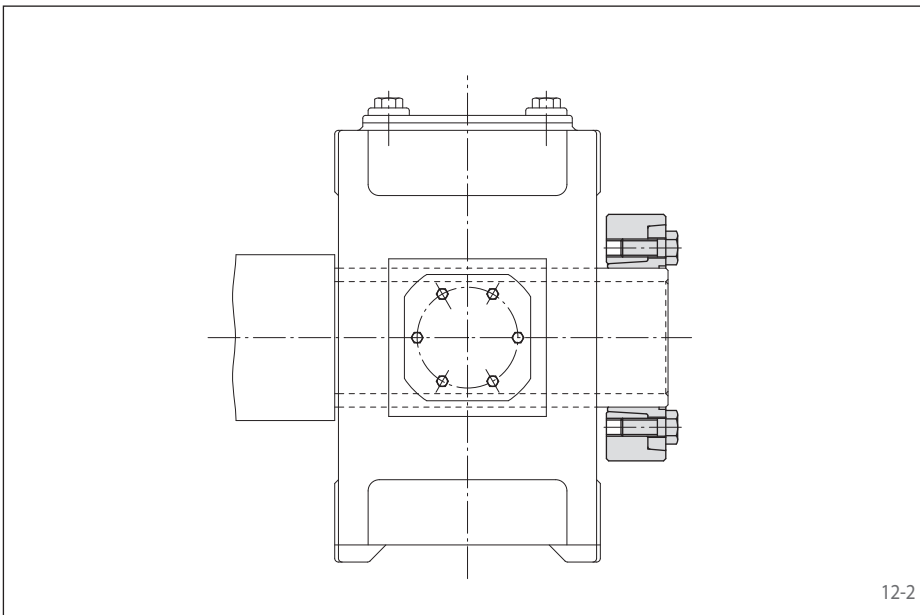

12-2

Application example

Backlash free connection of a hollow-shaft gearbox to a machine shaft with a Shrink Disc RLK 608. The backlash free connection reduces the risk of fretting corrosion. As a result, the connection can be easily disassembled even after long periods of operation.

Transmissible torques and axial forces

The transmissible torques or axial forces listed on the following three pages are subject to the following tolerances, surface characteristics and material requirements. Please contact us in the case of deviations.

Tolerances

d _w		Hollow shaft bore ISO	Shaft ISO	Joint clearance	
> mm	≤ mm			min. mm	max. mm
24	30	H7	h6	0	0,034
30	50			0	0,041
50	80			0	0,049
80	120			0	0,057
120	160			0	0,065
160	180	H7	g6	0,014	0,079
180	250			0,015	0,090
250	315			0,017	0,101
315	390			0,018	0,111

Other fits may be selected, provided the joint clearance between the shaft and the hollow shaft remains within the indicated ranges.

Surfaces

Average surface roughness at the contact surfaces between the shaft and the hollow shaft $R_z = 10 \dots 25 \mu\text{m}$.

Materials

The following apply to the shaft and the hollow shaft:

- Yield strength $R_e \geq 360 \text{ N/mm}^2$
- E-module ca. 206 kN/mm^2

Installation

Please request our installation and operating instructions for Shrink Discs RLK 608.

Simultaneous transmission of torque and axial force

The transmissible torques M which are shown in the tables apply for axial forces $F = 0 \text{ kN}$ and conversely, the indicated axial forces F apply to torques $M = 0 \text{ Nm}$. If torque and axial force are to be transmitted simultaneously, the transmissible torque and the transmissible axial force are reduced. Please refer to the technical points on page 31.

Example for ordering

Shrink Disc RLK 608 for hollow shaft with an outer diameter $d = 155 \text{ mm}$:

- RLK 608-155
Article number 4200-155801-000000

two-part design
highest torque capacity

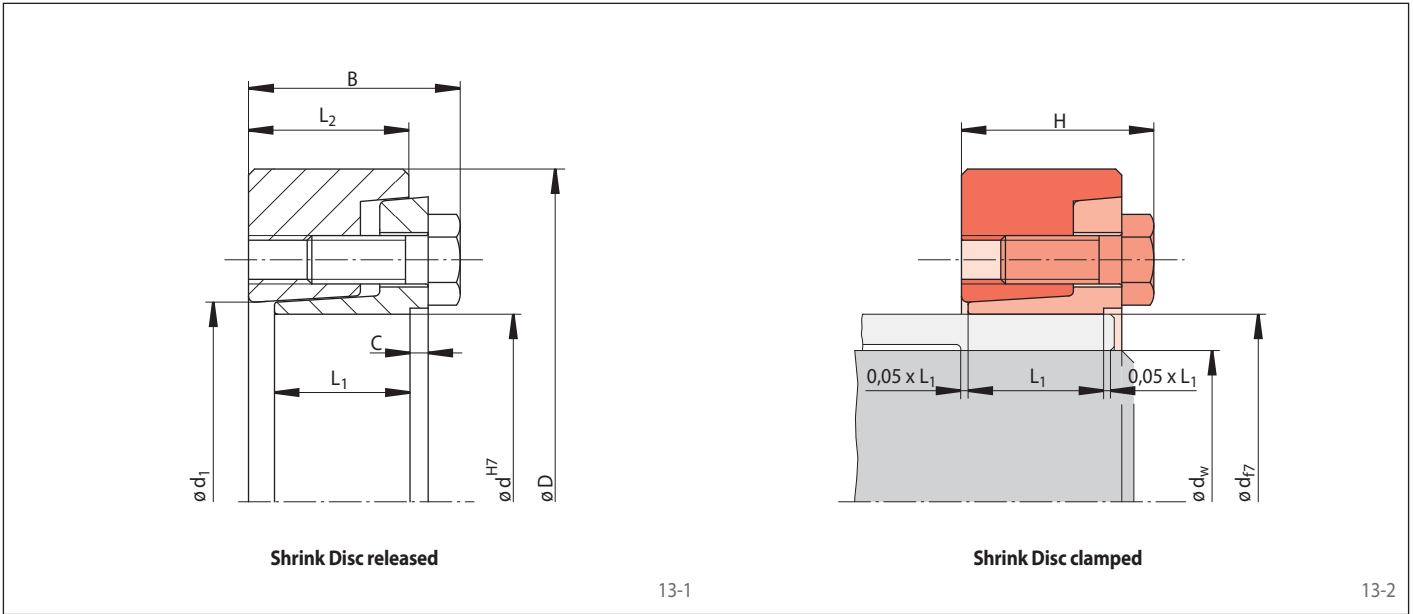

Dimensions									Technical Data					Article number	
Size d mm	D mm	d ₁ mm	B mm	L ₁ mm	L ₂ mm	C mm	H mm	d _w * mm	Transmissible torque or axial force		Clamping screws				Weight kg
									M Nm	F kN	Number	Size	Length mm		
30	60	32	25	16,5	19	2	23,0	24	330	27	6	M 6	16	0,3	4200-030801-000000
								25	370	29					
								26	415	31					
								27	660	48					
36	72	38	28	18	20,5	2	25,8	30	850	56	5	M 8	20	0,5	4200-036801-000000
								33	1070	64					
								34	950	55					
								35	1030	58					
44	80	47	30	20	22,5	2	27,8	37	1200	64	6	M 8	20	0,6	4200-044801-000000
								38	1750	92					
								40	2000	100					
								42	2250	105					
50	90	53	33	22	24,5	2	29,8	42	2050	97	8	M 8	20	0,8	4200-050801-000000
								45	2400	100					
								48	2800	110					
								48	2900	120					
55	100	58	35	23	26,5	3	31,8	50	3200	120	8	M 8	20	1,1	4200-055801-000000
								52	3550	130					
								50	3000	120					
								55	3800	130					
62	110	66	35	23	26,5	3	31,8	60	4650	150	9	M 8	20	1,3	4200-062801-000000
								55	4900	170					
								60	6100	200					
								65	7400	220					
68	115	72	35	23	26,5	3	31,8	60	5200	170	10	M 10	25	2,4	4200-075801-000000
								65	6400	190					
								70	7700	220					
								65	6900	210					
75	138	79	40	25	29	3	35,4	70	8200	230	10	M 10	30	3,4	4200-080801-000000
								75	9700	250					
								70	8800	250					
								75	10350	270					
80	141	84	40	25	29	3	35,4	80	12000	300	12	M 10	30	4,6	4200-100801-000000
								80	15500	380					
								85	17800	410					
								90	20000	440					
90	155	94	46	30	35	4	41,4	80	15500	380	12	M 12	35	6,6	4200-105801-000000
								85	17800	410					
								90	20000	440					
								80	15500	380					
100	170	104	51	34	40	5	46,4	85	17200	400	12	M 12	35	7,7	4200-110801-000000
								90	19700	430					
								95	22300	460					
								90	19150	420					
105	185	114	59	39	46	6	53,5	95	21700	450	12	M 12	35	9,2	4200-120801-000000
								100	24400	480					
								95	25900	540					
								100	29000	580					
120	200	124	63	42	49	6	56,5	100	36000	650	14	M 12	35	11,7	4200-130801-000000
								110	29000	580					
								110	15500	380					
								85	17200	400					

*The shaft diameters d_w listed in the table are selected examples. For other shaft diameters d_w see the technical specifications on page 31.

two-part design
highest torque capacity

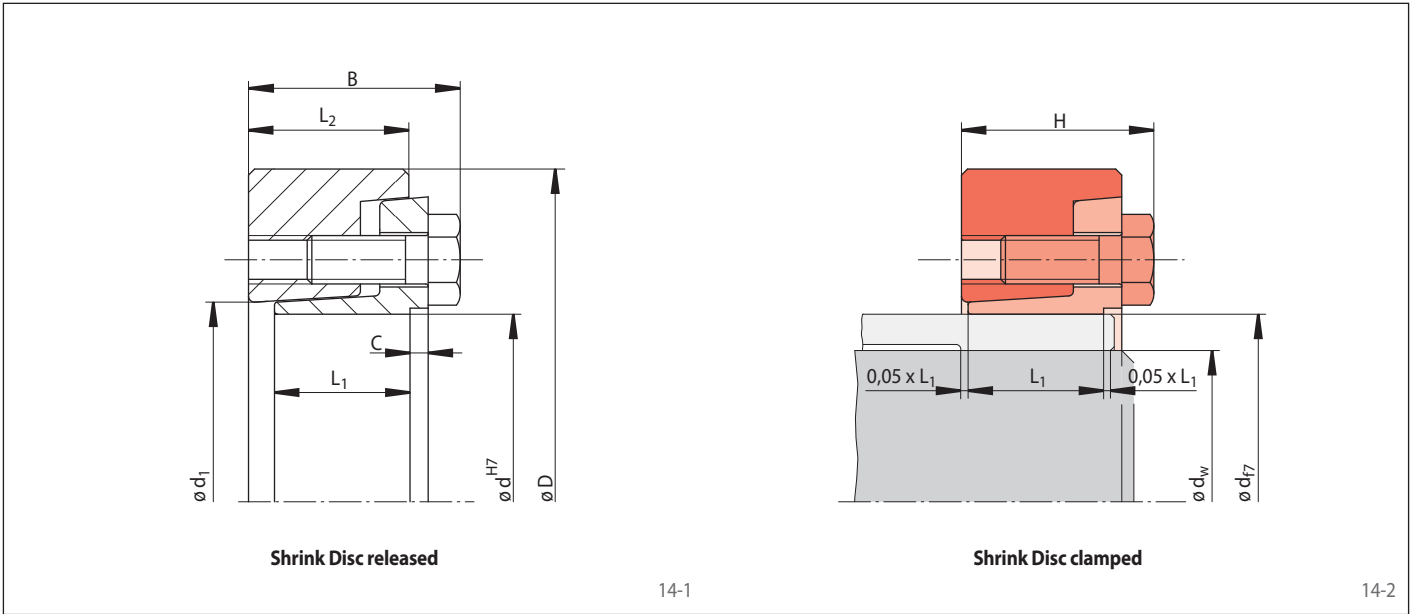

Dimensions									Technical Data					Article number	
Size d mm	D mm	d ₁ mm	B mm	L ₁ mm	L ₂ mm	C mm	H mm	d _w * mm	Transmissible torque or axial force		Clamping screws				Weight kg
									M Nm	F kN	Number	Size	Length mm		
140	230	144	71	46	53	6	61,8	100	27000	540	12	M 14	40	10,8	4200-140801-000000
								105	30200	570					
								115	37000	640					
150	263	159	75	50	57	6	65,8	110	35700	640	12	M 14	40	16,3	4200-150801-000000
								115	39500	680					
								125	47500	760					
155	263	159	75	50	57	6	65,8	110	36200	650	12	M 14	40	15,8	4200-155801-000000
								115	40000	690					
								125	48000	760					
160	290	169	82	56	63	6	73,0	120	56000	930	12	M 16	50	22,6	4200-160801-000000
								125	61000	970					
								135	72500	1000					
165	290	169	82	56	63	6	73,0	120	56500	940	12	M 16	50	22,0	4200-165801-000000
								125	61500	980					
								135	72500	1000					
170	300	179	82	56	63	6	73,0	130	61000	930	12	M 16	50	23,6	4200-170801-000000
								135	66500	980					
								145	78000	1000					
175	300	179	82	56	63	6	73,0	130	61500	940	12	M 16	50	22,9	4200-175801-000000
								135	67000	990					
								140	72500	1000					
180	320	191	99	72	79	6	89,0	140	97500	1300	16	M 16	50	33,9	4200-180801-000000
								145	105000	1400					
								155	122000	1500					
185	320	191	99	72	79	6	89,0	140	96000	1300	16	M 16	50	33,0	4200-185801-000000
								145	104000	1400					
								155	120000	1500					
190	320	195	100	71	79	7	89,0	150	92000	1200	16	M 16	50	33,0	4200-190801-000001
								155	99000	1200					
								165	113500	1300					
195	340	206	100	71	79	7	89,0	150	107000	1400	16	M 16	50	37,6	4200-195801-000000
								155	115000	1400					
								165	129000	1500					
200	340	206	100	71	79	7	89,0	150	108000	1400	16	M 16	50	36,6	4200-200801-000000
								155	116000	1400					
								165	130000	1500					
220	370	228	121	87	95	7	107,5	160	160000	2000	16	M 20	60	51,6	4200-220801-000000
								170	182000	2100					
								180	206000	2200					
240	405	248	127	92	100	7	112,5	170	190000	2200	18	M 20	60	65,3	4200-240801-000000
								180	215000	2300					
								200	269000	2600					
260	430	268	137	102	110	7	122,5	190	247000	2600	21	M 20	60	79,1	4200-260801-000000
								200	277000	2700					
								220	340000	3000					
280	460	288	150	115	123	7	135,5	210	335000	3100	22	M 20	60	100,0	4200-280801-000000
								220	370000	3300					
								240	449000	3700					

* The shaft diameters d_w listed in the table are selected examples. For other shaft diameters d_w see the technical specifications on page 31.

two-part design
highest torque capacity

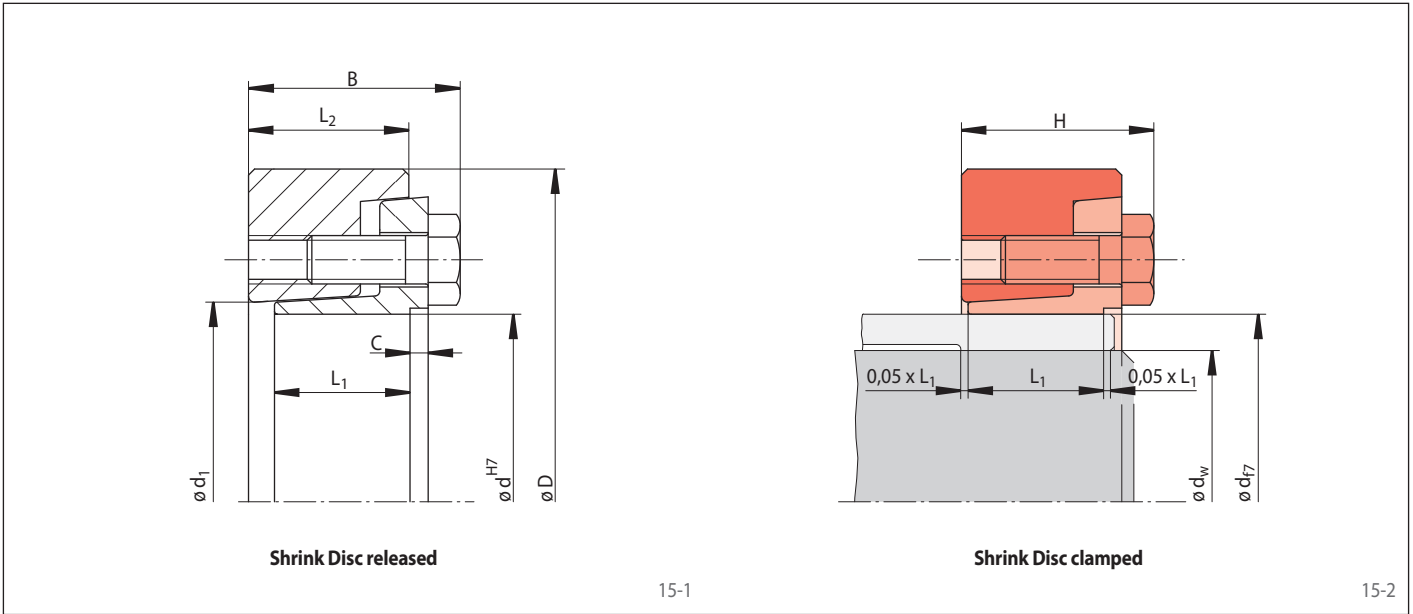

Dimensions									Technical Data			Article number			
Size d mm	D mm	d ₁ mm	B mm	L ₁ mm	L ₂ mm	C mm	H mm	d _w * mm	Transmissible torque or axial force		Clamping screws			Weight kg	Article number
									M Nm	F kN	Number	Size	Length mm		
300	485	308	162	122	131	8	146	220	386 000	3 500	20	M 24	80	116,3	4200-300801-000000
								230	425 000	3 600					
								250	508 000	4 000					
320	520	328	158	116	125	8	140	240	465 500	3 800	18	M 24	80	129,0	4200-320801-000000
								250	509 000	4 000					
								270	600 000	4 000					
340	570	348	170	127	136	8	151	250	564 000	4 500	20	M 24	80	175,0	4200-340801-000000
								260	612 000	4 700					
								280	719 000	5 100					
360	590	369	177	133	142	8	157	270	658 000	4 800	20	M 24	80	197,0	4200-360801-000000
								280	712 000	5 000					
								300	825 000	5 500					
390	650	399	195	144	153	8	172	290	903 000	6 200	18	M 30	100	254,0	4200-390801-000000
								300	970 000	6 400					
								320	1 110 000	6 900					
420	670	428	203	162	167	4	189	320	1 084 000	6 700	20	M 27	80	285,0	4200-420801-000001
								330	1 158 000	7 000					
								350	1 313 000	7 500					
440	725	448	222	173	180	6	202	340	1 353 000	7 900	21	M 27	80	371,0	4200-440801-000001
								350	1 440 000	8 200					
								370	1 621 000	8 700					
460	760	468	225	173	180	6	202	360	1 509 000	8 300	21	M 27	80	409,0	4200-460801-000001
								370	1 600 000	8 600					
								390	1 790 000	9 100					
480	790	488	249	198	202	3	226	380	1 860 000	9 700	21	M 30	100	495,0	4200-480801-000000
								390	1 966 000	10 000					
								410	2 186 000	10 600					
500	835	508	244	195	199	3	223	400	2 098 000	10 400	24	M 30	100	554,0	4200-500801-000000
								410	2 210 000	10 700					
								430	2 445 000	11 300					
530	870	538	266,3	213	216	3	240	430	2 645 000	12 300	24	M 30	100	638,0	4200-530801-000000
								440	2 777 000	12 500					
								460	3 050 000	13 000					
560	920	568	268,5	217	221	3	245	450	2 778 000	12 000	24	M 30	100	730,0	4200-560801-000000
								460	2 912 000	12 500					
								480	3 190 000	13 000					
590	960	598	284	232	237	4	261	470	3 238 000	13 500	28	M 30	100	842,0	4200-590801-000000
								480	3 386 000	14 000					
								500	3 693 000	14 500					
620	970	630	310	254	259	4	283	500	3 585 000	14 000	28	M 30	100	892,0	4200-620801-000000
								520	3 898 000	14 500					
								540	4 225 000	15 500					

* The shaft diameters d_w listed in the table are selected examples. For other shaft diameters d_w see the technical specifications on page 31.

two-part design
high torque capacity

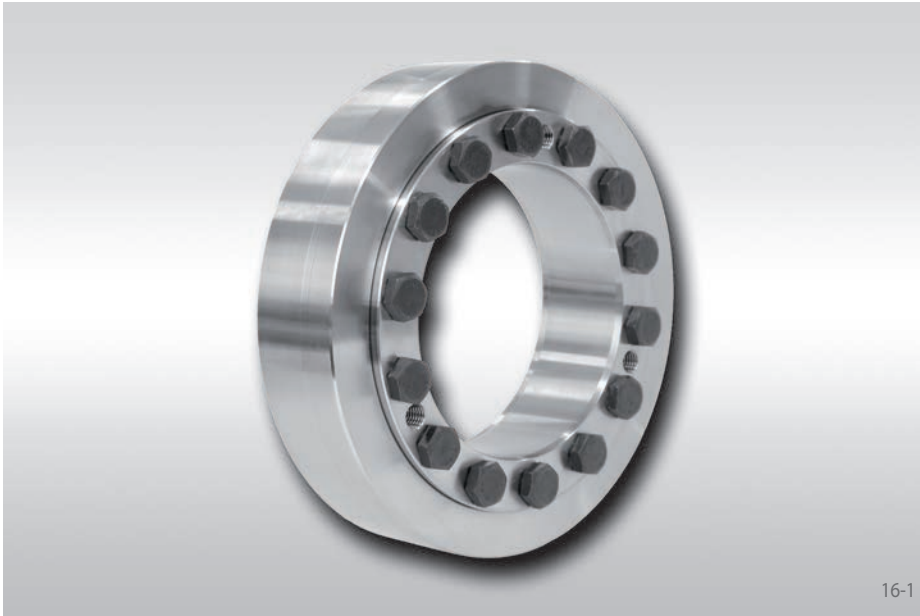

16-1

Features

- High torque capacity
- Transmissible torque of 165 Nm up to 36 200 Nm
- Easy, quick assembly by tightening clamping screws without a torque wrench
- Distance-controlled assembly ensures guaranteed transmissible torques
- Enclosed design, therefore impervious to dirt
- True running even at high speeds
- Centres the hollow shaft or hub to the shaft
- For hollow shafts or hubs with outer diameters of 24 mm up to 155 mm

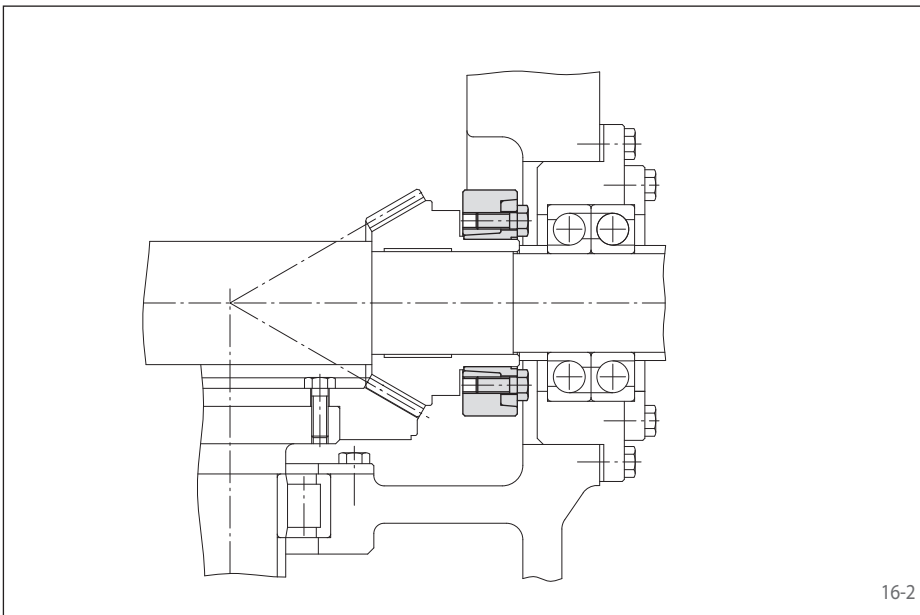

16-2

Application example

Backlash free connection of a bevel spur gear to a drive shaft of a gearbox with a Shrink Disc RLK 606. The backlash free connection permits extended reversing operations.

Transmissible torques and axial forces

The transmissible torques or axial forces listed on the following two pages are subject to the following tolerances, surface characteristics and material requirement. Please contact us in the case of deviations.

Tolerances

d _w		Hollow shaft bore ISO	Shaft ISO	Joint clearance	
> mm	≤ mm			min. mm	max. mm
24	30	H7	h6	0	0,034
30	50			0	0,041
50	80			0	0,049
80	120			0	0,057
120	155			0	0,065

Other fits may be selected, provided the joint clearance between the shaft and the hollow shaft remains within the indicated ranges.

Surfaces

Average surface roughness at the contact surfaces between the shaft and the hollow shaft $R_z = 10 \dots 25 \mu\text{m}$.

Materials

The following apply to the shaft and the hollow shaft:

- Yield strength $R_e \geq 340 \text{ N/mm}^2$
- E-module ca. 206 kN/mm^2

Installation

Please request our installation and operating instructions for Shrink Discs RLK 606.

Simultaneous transmission of torque and axial force

The transmissible torques M which are shown in the tables apply for axial forces $F = 0 \text{ kN}$ and conversely, the indicated axial forces F apply to torques $M = 0 \text{ Nm}$. If torque and axial force are to be transmitted simultaneously, the transmissible torque and the transmissible axial force are reduced. Please refer to the technical points on page 31.

Example for ordering

Shrink Disc RLK 606 for hollow shaft with an outer diameter $d = 100 \text{ mm}$:

- RLK 606-100
Article number 4200-100601-000000

two-part design
high torque capacity

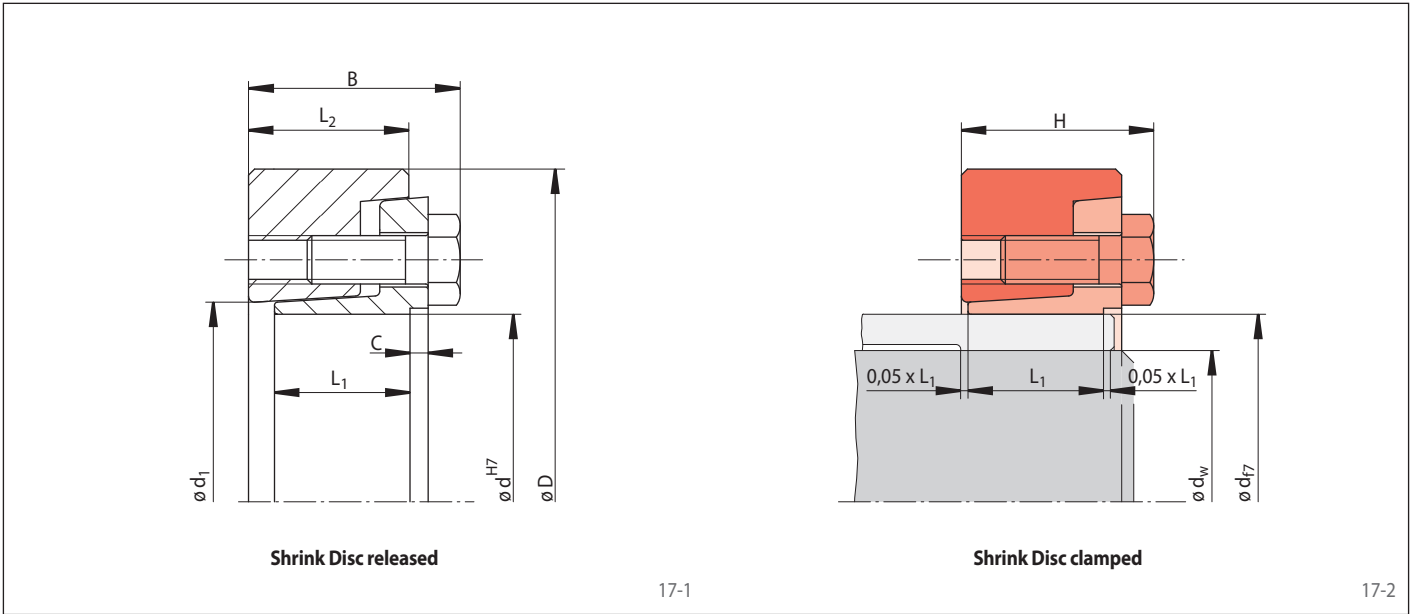

Dimensions									Technical Data					Article number	
Size d mm	D mm	d ₁ mm	B mm	L ₁ mm	L ₂ mm	C mm	H mm	d _w * mm	Transmissible torque or axial force		Clamping screws				Weight kg
									M Nm	F kN	Number	Size	Length mm		
24	50	26	22	15	17	1	21,0	19	165	17	5	M 6	16	0,3	4200-024601-000000
								20	210	21					
								21	240	22					
30	60	32	24	17	19	1	23,0	24	280	23	6	M 6	16	0,3	4200-030601-000000
								25	330	26					
								26	370	28					
36	72	39	27,5	19	20,5	1	25,8	27	480	35	5	M 8	20	0,5	4200-036601-000000
								30	630	42					
								33	820	49					
40	80	47	29,5	20,5	22,5	1,5	27,8	30	480	32	6	M 8	20	0,6	4200-040601-000000
								32	580	36					
								34	700	41					
44	80	47	29,5	20,5	22,5	1,5	27,8	34	720	42	6	M 8	20	0,6	4200-044601-000000
								35	780	44					
								37	920	49					
50	90	53	31	22	24	1,5	29,3	38	1150	60	8	M 8	20	0,8	4200-050601-000000
								40	1300	65					
								42	1520	72					
55	100	58	34,5	24,5	27	1,5	32,3	42	1300	61	8	M 8	20	1,2	4200-055601-000000
								45	1600	71					
								48	1900	79					
62	110	66	34,5	24,5	27	1,5	32,3	48	1700	70	9	M 8	20	1,5	4200-062601-000000
								50	1950	78					
								52	2160	83					
68	115	72	35	24,5	27	1,5	32,3	50	1900	76	9	M 8	20	1,6	4200-068601-000000
								55	2500	90					
								60	3150	105					
75	138	79	38	25	28	2	34,4	55	2700	98	10	M 10	25	2,6	4200-075601-000000
								60	3400	113					
								65	4100	126					
80	141	84	38	25	28	2	34,4	60	3300	110	10	M 10	25	2,8	4200-080601-000000
								65	4100	126					
								70	4950	141					
90	155	94	45	31,5	35	2,5	41,4	65	5500	169	11	M 10	25	3,4	4200-090601-000000
								70	6600	188					
								75	7900	210					
100	170	104	50,5	36,5	40	2,5	46,4	70	6200	177	14	M 10	30	4,6	4200-100601-000000
								75	7400	197					
								80	8600	215					
110	185	114	57	40,5	45,5	3	53,0	80	10500	262	12	M 12	35	6,2	4200-110601-000000
								85	11800	277					
								90	13700	304					
120	197	124	61	45	49	3	56,5	85	12500	294	14	M 12	35	7,4	4200-120601-000000
								90	14100	313					
								95	16000	336					
125	215	134	61,5	45	49	3	56,5	90	14500	322	14	M 12	35	9,3	4200-125601-000000
								95	16600	349					
								100	18800	376					

*The shaft diameters d_w listed in the table are selected examples. For other shaft diameters d_w see the technical specifications on page 31.

two-part design
high torque capacity

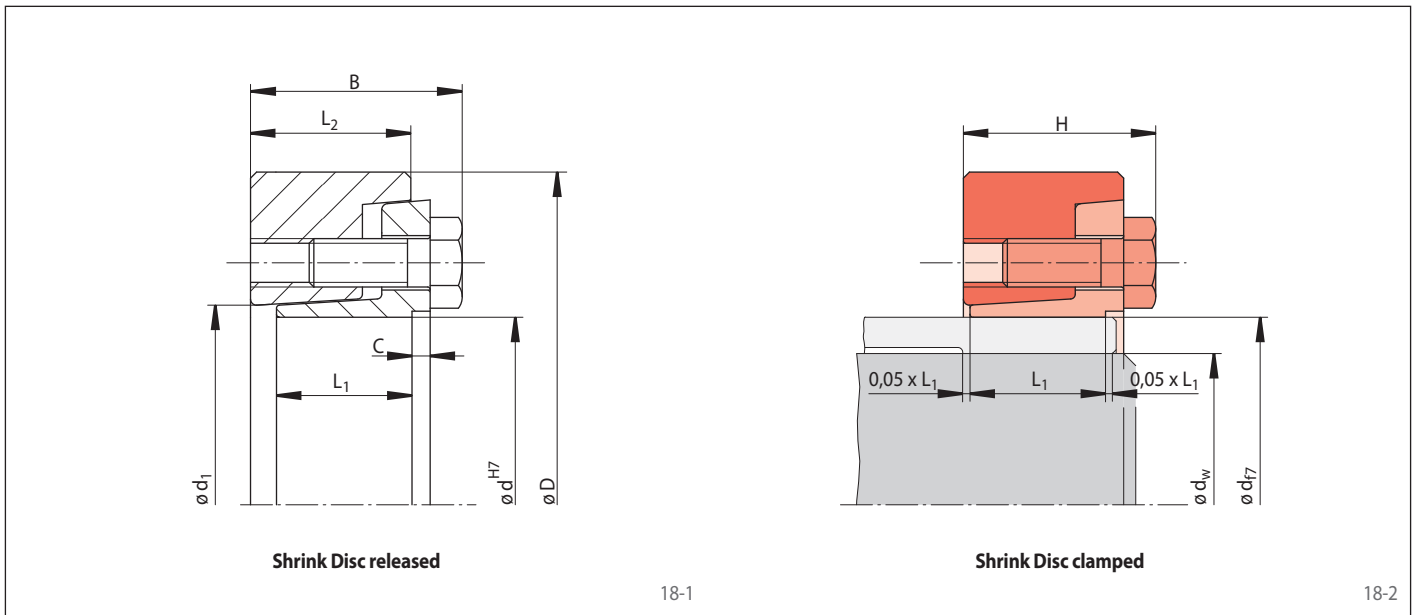

Dimensions									Technical Data					Article number	
Size d mm	D mm	d ₁ mm	B mm	L ₁ mm	L ₂ mm	C mm	H mm	d _w * mm	Transmissible torque or axial force		Clamping screws				Weight kg
									M Nm	F kN	Number	Size	Length mm		
130	215	134	61,5	45	49	3	56,5	95	17000	357	14	M 12	35	8,7	4200-130601-000000
								100	18400	368					
								110	22000	400					
130	230	139	66,5	47	53	4	61,8	95	18400	387	12	M 14	40	11,9	4200-130601-000001
								100	20800	416					
								110	26200	476					
140	230	144	67	47	53	4	61,8	100	19900	398	12	M 14	40	11,0	4200-140601-000000
								105	22200	422					
								115	27800	483					
150	263	159	72	51	57	4	65,8	110	27000	490	14	M 14	40	16,0	4200-150601-000000
								120	32000	533					
								125	36200	579					
155	263	159	72	51	57	4	65,8	110	27000	490	14	M 14	40	16,0	4200-155601-000000
								120	32000	533					
								125	36200	579					

* The shaft diameters d_w listed in the table are selected examples. For other shaft diameters d_w see the technical specifications on page 31.

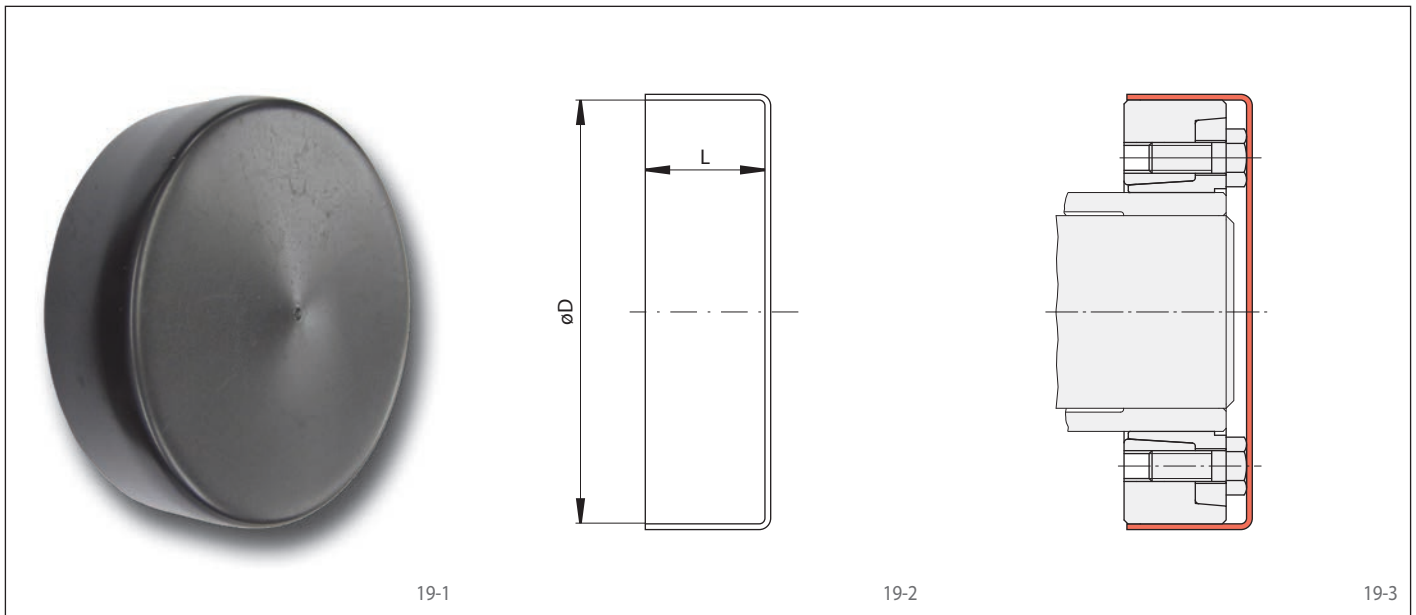

Characteristics

The cost-effective covers made from black plastic (PVC) provide simple contact protection for Shrink Discs RLK 608 and RLK 606 against the screw heads of the rotating Shrink Disc.

Example for ordering

Cover for Shrink Disc RLK 608-100:

- Cover size 100:
Article number 5025-168901-000000

Size	Covers for shrink discs		Dimensions		Weight kg	Article number
	RLK 608	RLK 606	D mm	L mm		
36	RLK 608-36	RLK 606-36	72	27	0,02	5025-070901-000000
44	RLK 608-44	RLK 606-44	80	29	0,04	5025-078901-000000
50	RLK 608-50	RLK 606-50	90	31	0,10	5025-087901-000000
62	RLK 608-62	RLK 606-62	110	33	0,08	5025-108901-000000
68	RLK 608-68	RLK 606-68	115	33	0,08	5025-113901-000000
75	RLK 608-75	RLK 606-75	138	36	0,10	5025-136901-000000
80	RLK 608-80	RLK 606-80	141	36	0,15	5025-139901-000000
100	RLK 608-100	RLK 606-100	170	48	0,15	5025-168901-000000
120	RLK 608-120	RLK 606-120	197	60	0,20	5025-195901-000000
125	RLK 608-125	RLK 606-125	215	58	0,25	5025-210901-000000
140	RLK 608-140	RLK 606-140	230	65	0,40	5025-228901-000000
155	RLK 608-155	RLK 606-155	263	67	0,45	5025-261901-000000
190	RLK 608-190	RLK 606-190	320	90	0,84	5025-320901-000000

three-part design
high torque capacity

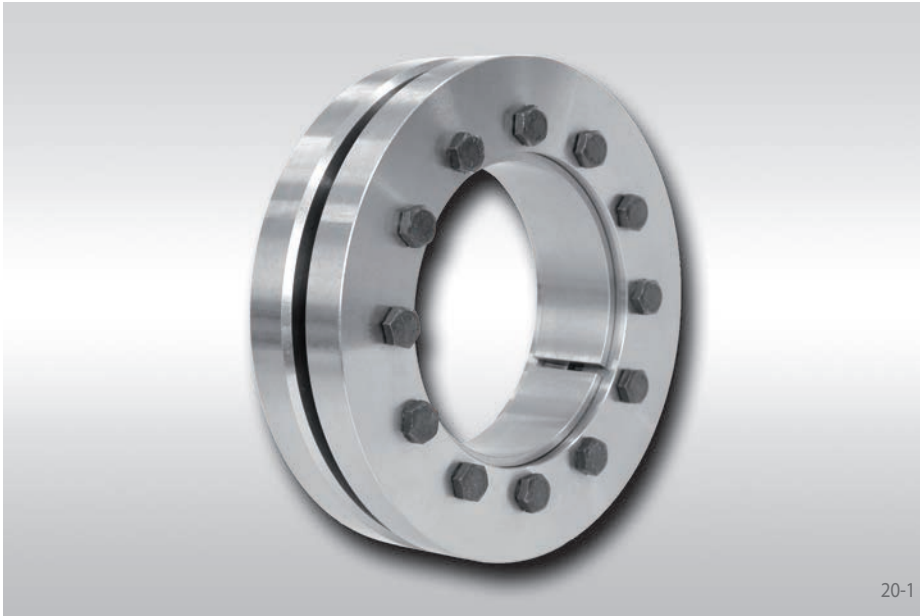

20-1

Features

- High torque capacity
- Transmissible torque of 25 Nm up to 1 460 000 Nm
- Tightening of clamping screws with a torque wrench
- Easy disassembly without jacking screws
- Centres the hollow shaft or hub to the shaft
- For hollow shafts or hubs with outer diameters of 14 mm up to 500 mm

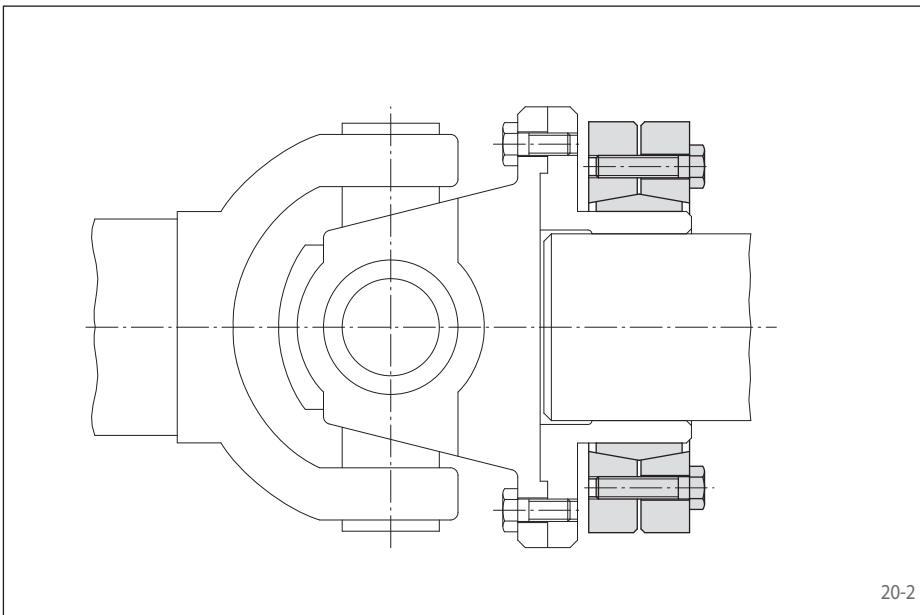

20-2

Application example

Backlash free connection of a cardan shaft flange to a machine shaft with a Shrink Disc RLK 603. The backlash free connection reduces the risk of fretting corrosion. As a result, the connection can be easily disassembled even after long periods of operation.

Transmissible torques and axial forces

The transmissible torques or axial forces listed on the following three pages are subject to the following tolerances, surface characteristics and material requirement. Please contact us in the case of deviations.

Tolerances

d _w		Hollow shaft bore ISO	Shaft ISO	Joint clearance	
> mm	≤ mm			min. mm	max. mm
6	10	H6	j6	-0,007	0,011
10	18			-0,008	0,014
18	30			-0,009	0,017
30	50	H6	h6	0	0,032
50	80	H6	g6	0,029	0,048
80	120	H7	g6	0,012	0,069
120	180			0,014	0,079
180	250			0,015	0,090
250	315			0,017	0,101
315	360			0,018	0,111

Other fits may be selected, provided the joint clearance between the shaft and the hollow shaft remains within the indicated ranges.

Surfaces

Average surface roughness at the contact surfaces between the shaft and the hollow shaft $R_z = 10 \dots 25 \mu\text{m}$.

Materials

The following apply to the shaft and the hollow shaft:

- Yield strength $R_e \geq 340 \text{ N/mm}^2$
- E-module ca. 206 kN/mm^2

Installation

Please request our installation and operating instructions for Shrink Discs RLK 603.

Simultaneous transmission of torque and axial force

The transmissible torques M which are shown in the tables apply for axial forces $F = 0 \text{ kN}$ and conversely, the indicated axial forces F apply to torques $M = 0 \text{ Nm}$. If torque and axial force are to be transmitted simultaneously, the transmissible torque and the transmissible axial force are reduced. Please refer to the technical points on page 31.

Example for ordering

Shrink Disc RLK 603 for hollow shaft with an outer diameter $d = 100 \text{ mm}$:

- RLK 603-100
Article number 4200-100301-000000

three-part design
high torque capacity

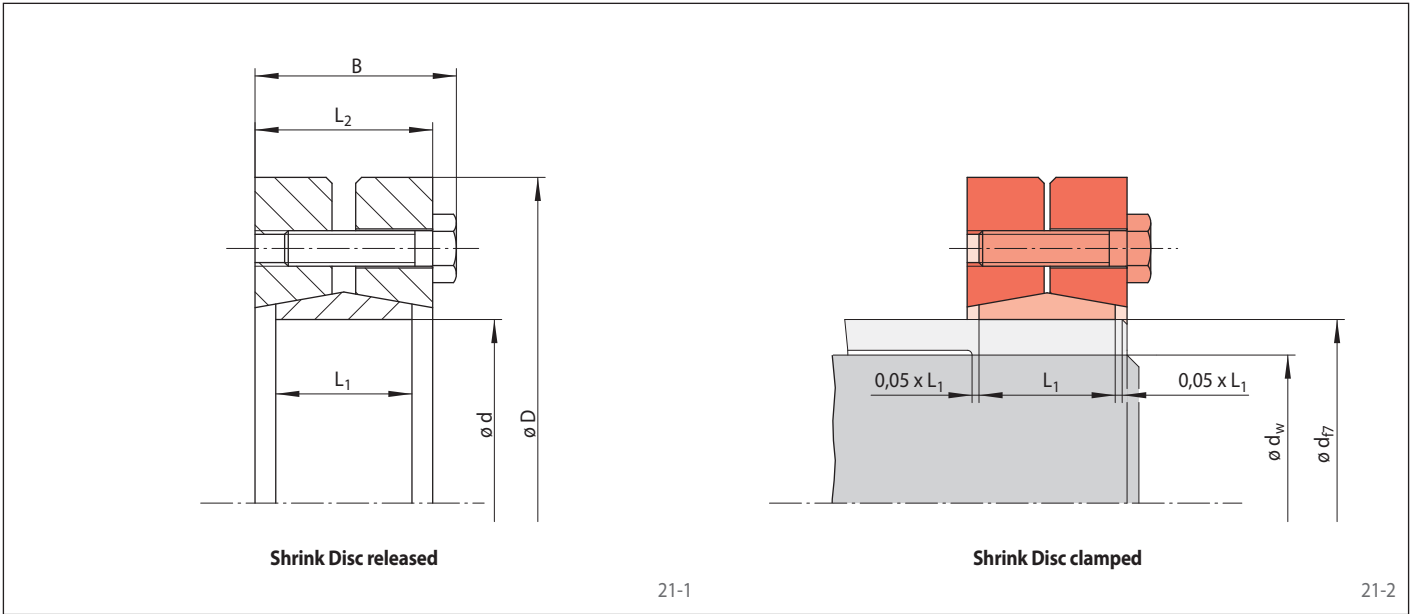

Dimensions						Technical Data							Article number
Size d mm	D mm	B mm	L ₁ mm	L ₂ mm	d _w * mm	Transmissible torque or axial force		Clamping screws				Weight kg	
						M Nm	F kN	Tightening torque M _s Nm	Number	Size	Length mm		
14	38	15	9	11	10	25	5	4	4	M 5	10	0,1	4200-014301-000000
					11	35	6						
					12	50	8						
16	41	19	11	15	12	50	8	4	5	M 5	14	0,1	4200-016301-000000
					13	70	10						
					14	90	12						
20	50	23	14	19	15	130	17	4	6	M 5	18	0,2	4200-020301-000000
					16	150	18						
					18	200	22						
24	50	23	14	19	19	180	18	4	6	M 5	18	0,2	4200-024301-000000
					20	210	21						
					21	250	23						
30	60	25	16	21	24	310	25	6	6	M 5	18	0,3	4200-030301-000000
					25	340	27						
					26	380	29						
36	72	27	18	23	28	460	32	12	5	M 6	20	0,5	4200-036301-000000
					30	590	39						
					31	630	40						
44	80	29	20	25	32	630	39	12	7	M 6	22	0,6	4200-044301-A01000
					35	780	44						
					36	860	47						
50	90	31	22	27	38	940	49	12	8	M 6	22	0,8	4200-050301-A01001
					40	1100	55						
					42	1300	61						
55	100	34	23	30	42	1200	57	12	8	M 6	25	1,1	4200-055301-000000
					45	1500	66						
					48	1900	79						
62	110	34	23	30	48	1800	75	12	10	M 6	25	1,3	4200-062301-000000
					50	2200	88						
					52	2400	92						
68	115	34	23	30	50	2000	80	12	10	M 6	25	1,4	4200-068301-000000
					55	2500	90						
					60	3100	100						
75	138	37	25	32	55	2500	90	30	7	M 8	30	2,3	4200-075301-000000
					60	3200	100						
					65	3900	120						
80	145	37	25	32	60	3200	100	30	7	M 8	30	2,5	4200-080301-000000
					65	3900	120						
					70	4600	130						
90	155	44	30	39	65	4700	140	30	10	M 8	25	3,3	4200-090301-000000
					70	6000	170						
					75	7200	190						
100	170	49	34	44	70	6300	180	30	12	M 8	35	4,4	4200-100301-000000
					75	7500	200						
					80	9000	220						
110	185	56	39	50	75	7200	190	59	9	M 10	40	6,0	4200-110301-000000
					80	9000	220						
					85	10400	240						

* The shaft diameters d_w listed in the table are selected examples. For other shaft diameters d_w see the technical specifications on page 31.

three-part design
high torque capacity

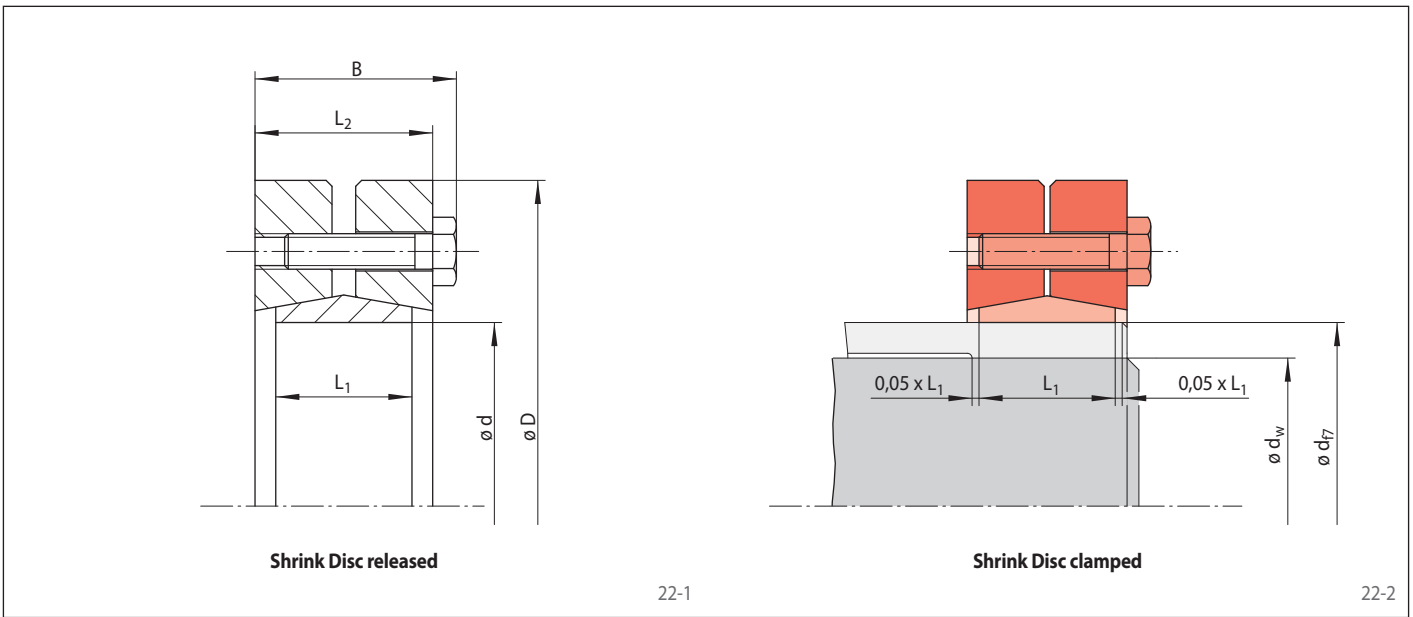

Dimensions						Technical Data							Article number
Size d mm	D mm	B mm	L ₁ mm	L ₂ mm	d _w * mm	Transmissible torque or axial force		Clamping screws				Weight kg	
						M Nm	F kN	Tightening torque M _s Nm	Number	Size	Length mm		
115	185	56	39	50	80	8 500	210	59	9	M 10	40	6,0	4200-115301-000000
					85	9 300	210						
					90	11 300	250						
120	215	58	42	52	80	10 500	260	59	12	M 10	40	9,0	4200-120301-000000
					85	12 100	280						
					90	14 400	320						
125	215	58	42	52	85	11 000	250	59	12	M 10	40	8,7	4200-125301-000000
					90	13 000	280						
					95	15 000	310						
130	215	58	42	52	90	12 000	260	59	12	M 10	40	8,3	4200-130301-000000
					95	14 400	300						
					100	17 000	340						
140	230	68	46	60	95	14 900	310	100	10	M 12	45	10,7	4200-140301-000000
					100	17 000	340						
					105	20 000	380						
155	265	72	50	64	105	20 000	380	100	12	M 12	50	16,0	4200-155301-000000
					110	23 000	410						
					115	26 000	450						
160	265	72	50	64	110	21 900	390	100	12	M 12	50	15,4	4200-160301-000000
					115	25 200	430						
					120	28 600	470						
165	290	81	56	71	115	31 500	540	250	8	M 16	60	21,7	4200-165301-000000
					120	35 600	590						
					125	39 000	620						
170	290	81	56	71	120	31 700	520	250	8	M 16	60	21,1	4200-170301-000000
					125	35 800	570						
					130	40 000	610						
175	300	81	56	71	125	34 500	550	250	8	M 16	60	22,7	4200-175301-000000
					130	38 900	590						
					135	43 400	640						
180	300	81	56	71	130	36 700	560	250	8	M 16	60	22,0	4200-180301-000000
					135	41 100	600						
					140	45 700	650						
185	330	96	71	86	135	49 200	720	250	10	M 16	65	35,0	4200-185301-000000
					140	54 600	780						
					145	60 400	830						
190	330	96	71	86	140	51 900	740	250	10	M 16	65	34,1	4200-190301-000000
					145	57 400	790						
					150	63 200	840						
195	350	96	71	86	140	61 600	880	250	12	M 16	65	39,6	4200-195301-000000
					150	74 500	990						
					155	81 300	1 040						
200	350	96	71	86	150	71 200	940	250	12	M 16	65	38,7	4200-200301-000000
					155	77 900	1 000						
					160	84 700	1 050						
220	370	114	88	104	160	90 700	1 130	250	15	M 16	80	50,0	4200-220301-000000
					165	98 600	1 190						
					170	106 000	1 240						

* The shaft diameters d_w listed in the table are selected examples. For other shaft diameters d_w see the technical specifications on page 31.

three-part design
high torque capacity

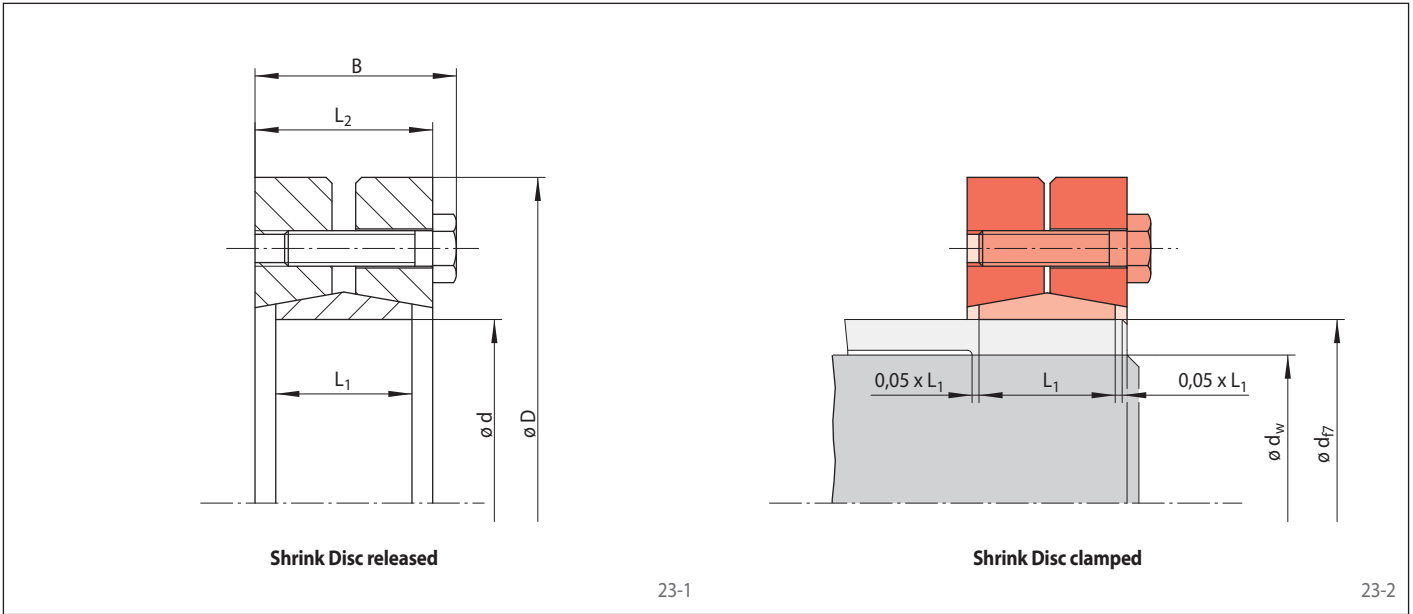

Dimensions						Technical Data							Article number
Size d mm	D mm	B mm	L ₁ mm	L ₂ mm	d _w * mm	Transmissible torque or axial force		Clamping screws				Weight kg	
						M Nm	F kN	Tightening torque M _s Nm	Number	Size	Length mm		
240	405	121	92	108	170	119 000	1 400	490	12	M 20	80	62,0	4200-240301-000000
					180	138 000	1 530						
					190	156 000	1 640						
260	430	133	103	120	190	161 000	1 690	490	14	M 20	90	77,0	4200-260301-000000
					200	184 000	1 840						
					210	204 000	1 940						
280	460	147	114	134	210	213 000	2 020	490	16	M 20	100	97,0	4200-280301-000000
					220	240 000	2 180						
					230	269 000	2 330						
300	485	155	122	142	230	274 000	2 380	490	18	M 20	100	116,0	4200-300301-000000
					240	296 000	2 460						
					245	316 000	2 570						
320	520	155	122	142	240	310 000	2 580	490	20	M 20	100	133,0	4200-320301-000000
					250	340 000	2 720						
					260	373 000	2 860						
340	570	169	134	156	250	381 000	3 040	490	24	M 20	110	183,0	4200-340301-000000
					260	412 000	3 160						
					270	453 000	3 350						
360	590	175	140	162	280	453 000	3 230	490	24	M 20	110	186,0	4200-360301-000000
					290	495 000	3 410						
					295	517 000	3 500						
380	645	183	144	168	290	570 000	3 900	840	20	M 24	120	239,0	4200-380301-000000
					300	610 000	4 070						
					310	660 000	4 260						
390	660	183	144	168	300	625 000	4 170	840	21	M 24	120	260,0	4200-390301-000000
					310	670 000	4 325						
					320	720 000	4 500						
400	680	183	144	168	315	671 000	4 270	840	21	M 24	120	280,0	4200-400301-000000
					320	695 000	4 340						
					330	745 000	4 500						
420	690	203	164	188	330	782 000	4 460	840	24	M 24	130	316,0	4200-420301-000000
					340	841 000	5 000						
					350	902 000	5 200						
440	750	217	177	202	340	805 000	4 760	840	24	M 24	140	408,0	4200-440301-000000
					350	861 000	4 930						
					360	920 000	5 120						
460	770	217	177	202	360	1 000 000	5 560	840	28	M 24	140	420,0	4200-460301-000000
					370	1 073 000	5 820						
					380	1 141 000	6 020						
480	800	228	188	213	380	1 175 000	6 200	840	30	M 24	140	505,0	4200-480301-000000
					390	1 250 000	6 450						
					400	1 312 000	6 580						
500	850	230	188	213	400	1 314 000	6 570	1 250	24	M 27	150	575,0	4200-500301-000000
					410	1 382 000	6 740						
					420	1 460 000	7 000						

* The shaft diameters d_w listed in the table are selected examples. For other shaft diameters d_w see the technical specifications on page 31.

three-part design
highest torque capacity



24-1

Features

- Highest torque capacity
- Transmissible torque of 18 Nm up to 156 100 Nm
- Tightening of clamping screws with a torque wrench
- Easy disassembly without jacking screws
- Centres the hollow shaft or hub to the shaft
- For hollow shafts or hubs with outer diameters of 14 mm up to 190 mm

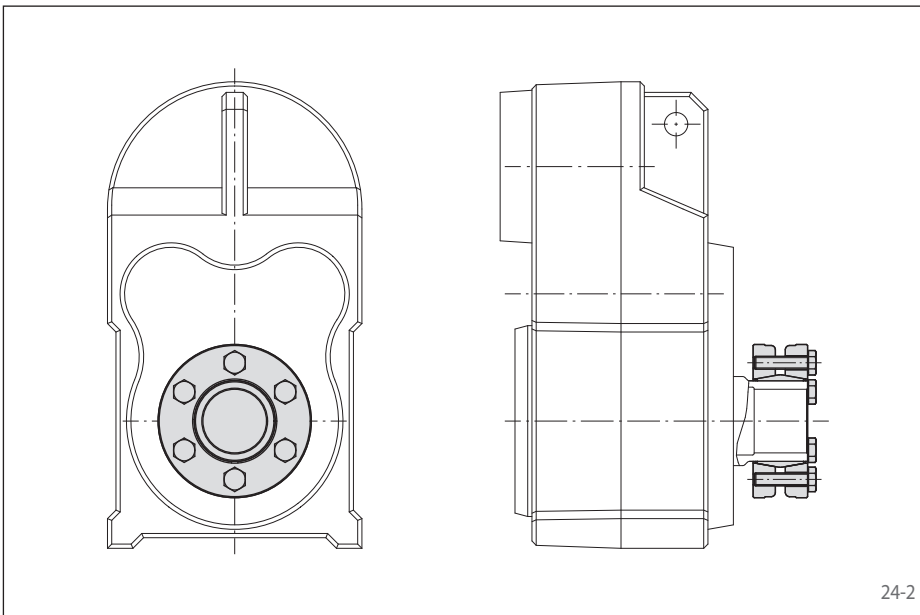

24-2

Application example

Backlash free connection of a hollow-shaft to a machine shaft on a flat gear box with a Shrink Disc RLK 603 S. The backlash free connection reduces the risk of fretting corrosion. As a result, the connection can be easily disassembled even after long periods of operation.

Transmissible torques and axial forces

The transmissible torques or axial forces listed on the following page are subject to the following tolerances, surface characteristics and material requirements. Please contact us in the case of deviations.

Tolerances

d_w		Hollow shaft bore ISO	Shaft ISO	Joint clearance	
> mm	≤ mm			min. mm	max. mm
6	10	H7	h6	0	0,024
10	18			0	0,029
18	30			0	0,034
30	50			0	0,041
50	80			0	0,049
80	120			0	0,057
120	150	H7	g6	0	0,065
150	180			0,014	0,079
180	250			0,015	0,090
250	315			0,017	0,101
315	400			0,018	0,111

Other fits may be selected, provided the joint clearance between the shaft and the hollow shaft remains within the indicated ranges.

Surfaces

Average surface roughness at the contact surfaces between the shaft and the hollow shaft $R_z = 10 \dots 25 \mu\text{m}$.

Materials

The following apply to the shaft and the hollow shaft:

- Yield strength $R_e \geq 340 \text{ N/mm}^2$
- E-module ca. 206 kN/mm^2

Installation

Please request our installation and operating instructions for Shrink Discs RLK 603 S.

Simultaneous transmission of torque and axial force

The transmissible torques M which are shown in the tables apply for axial forces $F = 0 \text{ kN}$ and conversely, the indicated axial forces F apply to torques $M = 0 \text{ Nm}$. If torque and axial force are to be transmitted simultaneously, the transmissible torque and the transmissible axial force are reduced. Please refer to the technical points on page 31.

Example for ordering

Shrink Disc RLK 603 S for hollow shaft with an outer diameter $d = 95 \text{ mm}$:

- RLK 603 S-95 x 170
Article number 4200-095301-C00000

three-part design
highest torque capacity

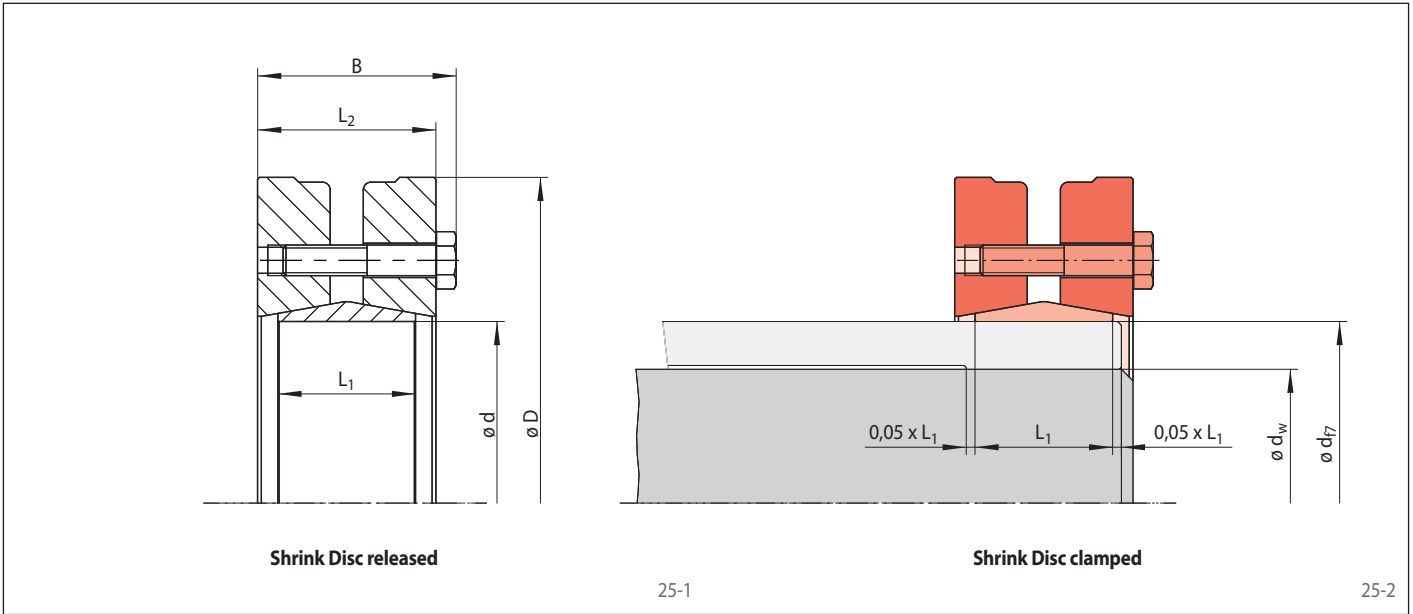

Dimensions						Technical Data							Article number
Size d mm	D mm	B mm	L ₁ mm	L ₂ mm	d _w * mm	Transmissible torque or axial force		Clamping screws				Weight kg	
						M Nm	F kN	Tightening torque M _s Nm	Number	Size	Length mm		
14	37	15	9	12	10	18	4,0	2,4	3	M 4	10	0,1	4200-014301-C00000
					11	37	7,0						
					12	59	10,5						
16	41	18,5	12	15	12	70	15	4	4	M 5	12	0,1	4200-016301-C00000
					13	90	18						
					14	110	20						
18	44	18,5	12	15	14	90	16	4	4	M 5	12	0,2	4200-018301-C00000
					15	100	18						
					16	120	20						
20	46	21	12	17,5	15	110	18	4	5	M 5	16	0,2	4200-020301-C00000
					16	140	22						
					17	160	24						
21	50	22,5	16	19	16	200	31	5	6	M 5	16	0,2	4200-021301-C00000
					17	230	34						
					18	260	37						
24	50	23	16	19	18	240	27	5	6	M 5	16	0,2	4200-024301-C00000
					19	270	28						
					20	310	31						
30	52	22	16	23	24	340	33	5	7	M 5	20	0,2	4200-030301-C00000
					25	470	42						
					26	540	46						
30	60	26	16	22	22	350	32	5	7	M 5	20	0,4	4200-030301-C00001
					24	450	38						
					25	500	40						
36	72	30	22	26	25	600	53	12	6	M 6	25	0,5	4200-036301-C00000
					28	790	58						
					30	800	61						
38	72	30	22	26	25	520	42	12	6	M 6	25	0,6	4200-038301-C00000
					28	730	52						
					30	890	59						
40	72	30	22	26	27	495	46	12	6	M 6	25	0,46	4200-040301-C00000
					30	720	61						
					32	790	70						
44	80	30	22	26	30	840	56	12	7	M 6	25	0,7	4200-044301-C00000
					32	950	59						
					35	1230	70						
48	80	30	22	26	35	1050	59	12	7	M 6	25	0,7	4200-048301-C00000
					38	1300	68						
					40	1500	75						
50	90	32	22	28	35	1350	75	12	9	M 6	25	1,0	4200-050301-C00000
					38	1620	85						
					40	1860	93						
55	100	35	23	31	42	1300	78	12	12	M 6	25	1,1	4200-055301-C00000
					45	1550	87						
					48	1800	96						
62	110	35	25	31	45	2500	111	12	12	M 6	25	1,6	4200-062301-C00000
					50	3250	130						
					55	4050	145						

*The shaft diameters d_w listed in the table are selected examples. For other shaft diameters d_w see the technical specifications on page 31.

three-part design
highest torque capacity

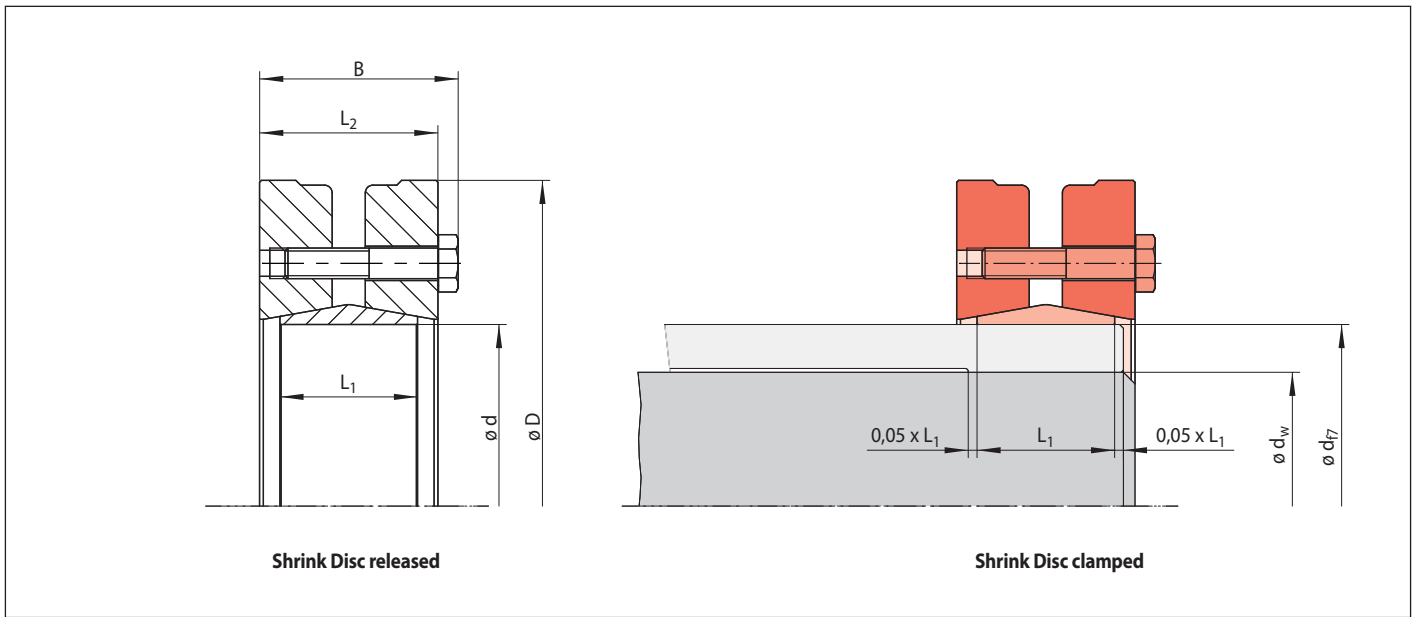

Dimensions						Technical Data							Article number
Size d mm	D mm	B mm	L ₁ mm	L ₂ mm	d _w * mm	Transmissible torque or axial force		Clamping screws				Weight kg	
						M Nm	F kN	Tightening torque M _s Nm	Number	Size	Length mm		
68	115	35,0	25	31	50	2 270	91	12	10	M 6	25	1,4	4200-068301-C00000
					55	3 210	117						
					60	3 610	120						
75	138	38,3	26	33	55	2 650	121	30	7	M 8	30	2,3	4200-075301-C00000
					60	3 300	139						
					65	4 050	158						
80	145	38,3	25	33	60	3 200	126	30	7	M 8	30	2,5	4200-080301-C00000
					65	3 900	143						
					70	4 600	160						
85	155	46,3	33	41	60	5 990	200	30	11	M 8	35	4,2	4200-085301-C00000
					65	7 290	224						
					70	9 130	261						
90	155	44,3	30	39	65	4 800	174	30	10	M 8	35	3,3	4200-090301-C00000
					70	6 050	195						
					75	7 300	215						
95	170	52,3	36	47	65	7 600	235	30	12	M 8	40	5,8	4200-095301-C00000
					70	9 400	270						
					75	11 400	304						
100	170	52,3	36	47	70	6 950	202	30	12	M 8	40	4,4	4200-100301-C00000
					75	7 600	223						
					80	9 100	245						
110	185	62	45	56	75	8 150	259	59	10	M 10	45	6,3	4200-110301-C00000
					80	10 100	285						
					85	12 200	296						
115	185	62	45	56	80	11 800	295	59	10	M 10	45	7,2	4200-115301-C00000
					85	13 600	320						
					90	15 700	349						
120	215	60	44	54	80	13 000	325	59	12	M 10	45	9,0	4200-120301-C00000
					85	15 600	367						
					90	18 300	407						
125	215	60	44	54	85	11 050	300	59	12	M 10	45	8,7	4200-125301-C00000
					90	13 100	327						
					95	15 150	355						
130	215	60	44	54	90	15 700	349	59	12	M 10	45	8,3	4200-130301-C00000
					95	18 300	385						
					100	21 200	424						
135	212	85	63	77	95	25 200	531	100	12	M 12	60	13,0	4200-135301-C00000
					100	29 000	580						
					105	33 100	630						
140	230	68	46	60	95	15 100	365	100	10	M 12	50	10,7	4200-140301-C00001
					100	17 550	395						
					105	20 000	424						
140	304	106	84	96	95	44 300	933	250	12	M 16	70	43,0	4200-140301-C00000
					105	56 700	1 080						
					110	63 600	1 156						
155	265	72	50	64	105	25 500	486	100	12	M 12	70	16,0	4200-155301-C00001
					110	29 200	531						
					115	33 100	576						

*The shaft diameters d_w listed in the table are selected examples. For other shaft diameters d_w see the technical specifications on page 31.

three-part design
highest torque capacity

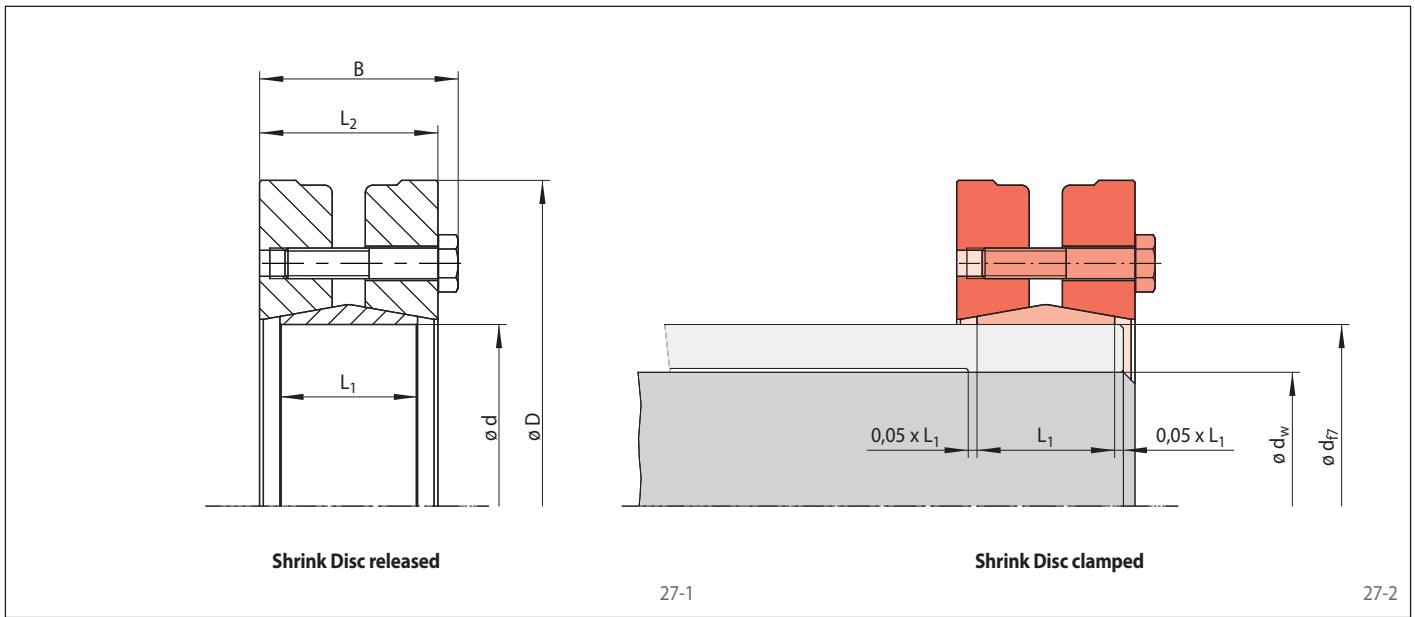

Dimensions						Technical Data							Article number
Size d mm	D mm	B mm	L ₁ mm	L ₂ mm	d _w * mm	Transmissible torque or axial force		Clamping screws				Weight kg	
						M Nm	F kN	Tightening torque M _s Nm	Number	Size	Length mm		
155	263	92	68	84	115	42 700	743	100	15	M 12	70	23,0	4200-155301-C00000
					120	47 700	795						
					125	52 900	846						
160	290	81	56	71	110	33 600	611	250	8	M 16	60	22,4	4200-160301-C00000
					115	37 900	659						
					120	42 400	707						
165	290	81	56	71	115	34 500	600	250	8	M 16	60	21,7	4200-165301-C00000
					120	39 000	650						
					125	43 300	693						
170	290	81	56	71	120	39 100	652	250	8	M 16	60	21,2	4200-170301-C00000
					125	42 700	683						
					130	47 300	728						
175	300	124	98	114	120	86 700	1 387	250	15	M 16	90	42,0	4200-175301-C00000
					125	95 600	1 471						
					130	104 900	1 554						
190	350	130	98	117	135	110 900	1 643	470	12	M 20	90	62,0	4200-190301-C00000
					145	132 600	1 829						
					155	156 100	2 014						

* The shaft diameters d_w listed in the table are selected examples. For other shaft diameters d_w see the technical specifications on page 31.

Shrink Discs RLK 603 K

three-part design
corrosion-resistant in stainless steel

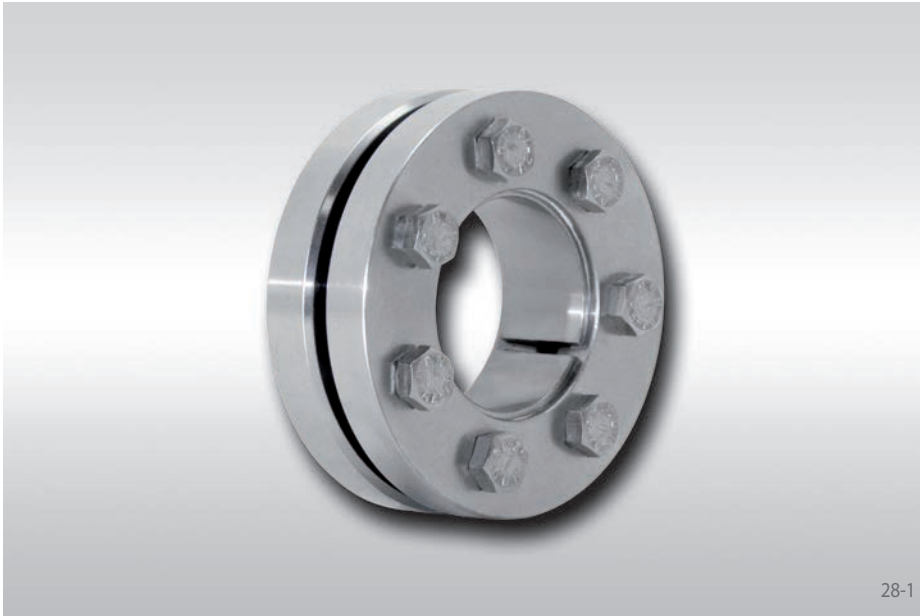

28-1

Features

- High torque capacity
- Transmissible torque of 170 Nm up to 23 000 Nm
- Tightening of clamping screws with a torque wrench
- Easy disassembly without jacking screws
- Centres the hollow shaft or hub to the shaft
- For hollow shafts or hubs with outer diameters of 24 mm up to 175 mm
- All parts in rust-free stainless steel
- High corrosion resistance
- Screws DIN 931/933 grade A2-70
- Lubricated with H1-registered grease

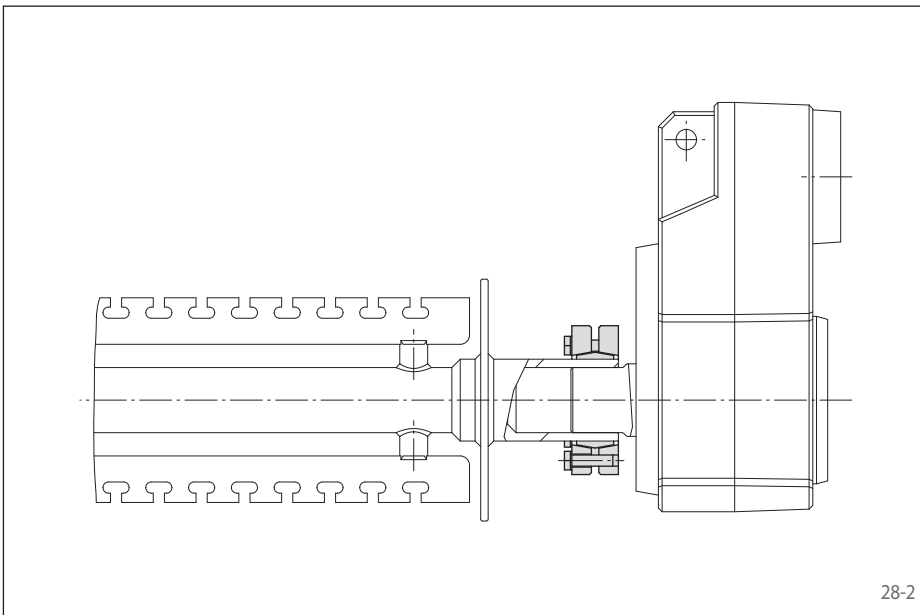

28-2

Application example

Adjustable in the direction of rotation, the Shrink Disc RLK 603 K ensures a backlash free connection of a stirring hook, which is used in a screening system for bakery products, to the gear drive. The use of a stainless steel material permits regular cleaning of the complete unit with cleaning fluids.

Transmissible torques and axial forces

The transmissible torques or axial forces listed on the following two pages are subject to the following tolerances, surface characteristics and material requirement. Please contact us in the case of deviations.

Tolerances

d _w		Hollow shaft bore ISO	Shaft ISO	Joint clearance max. mm
> mm	≤ mm			
6	10	H6	j6	0,011
11	18			0,014
19	30			0,017
31	50	H6	h6	0,032
51	80	H6	g6	0,048
81	120	H7	g6	0,069
121	180			0,079
181	250			0,090
251	315			0,101
316	400			0,111
401	500			0,123

Other fits may be selected, provided the joint clearance between the shaft and the hollow shaft remains within the indicated ranges.

Surfaces

Average surface roughness at the contact surfaces between the shaft and the hollow shaft R_z = 10 ... 25 µm.

Materials

The following apply to the shaft and the hollow shaft:

- Yield strength R_e ≥ 300 N/mm²
- E-module ca. 200 kN/mm²

Installation

Please request our installation and operating instructions for Shrink Discs RLK 603 K.

Simultaneous transmission of torque and axial force

The transmissible torques M which are shown in the tables apply for axial forces F = 0 kN and conversely, the indicated axial forces F apply to torques M = 0 Nm. If torque and axial force are to be transmitted simultaneously, the transmissible torque and the transmissible axial force are reduced. Please refer to the technical points on page 31.

Example for ordering

Shrink Disc RLK 603 K for hollow shaft with an outer diameter d = 100 mm:

- RLK 603 K-100
Article number 4200-100310-000000

three-part design
corrosion-resistant in stainless steel

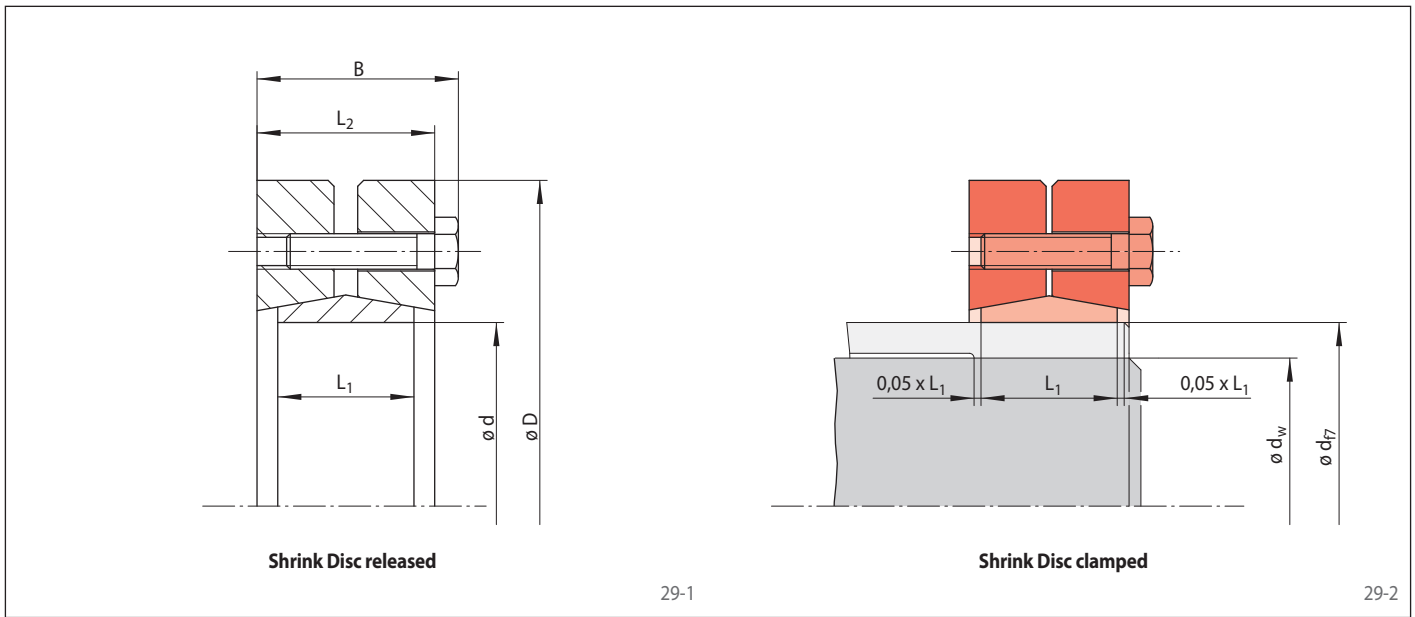

Dimensions						Technical Data							Article number
Size d mm	D mm	B mm	L ₁ mm	L ₂ mm	d _w * mm	Transmissible torque or axial force		Clamping screws				Weight kg	
						M Nm	F kN	Tightening torque M _s Nm	Number	Size	Length mm		
24	50	21,5	14	18	19	170	18	3,9	6	M 5	16	0,19	4200-024310-000000
					20	200	20						
					21	240	22						
30	60	23,5	16	20	24	200	16	3,9	7	M 5	18	0,29	4200-030310-000000
					25	220	18						
					26	240	19						
36	72	26,0	18	22	28	260	18	6,8	5	M 6	20	0,47	4200-036310-000000
					30	330	22						
					31	350	23						
44	80	28,0	20	24	34	350	22	6,8	7	M 6	20	0,6	4200-044310-000000
					35	440	25						
					36	480	27						
50	90	31,0	22	27	38	530	28	6,8	8	M 6	22	0,8	4200-050310-000000
					40	620	31						
					42	730	35						
55	100	33,0	23	29	42	680	32	6,8	8	M 6	25	1,1	4200-055310-000000
					45	850	37						
					48	1050	45						
62	110	33,0	23	29	48	1000	43	6,8	10	M 6	25	1,3	4200-062310-000000
					50	1200	50						
					52	1350	52						
68	115	33,0	23	29	50	1100	45	6,8	10	M 6	25	1,3	4200-068310-000000
					55	1400	51						
					60	1750	57						
75	138	36,3	25	31	55	1300	48	16	7	M 8	25	2,2	4200-075310-000000
					60	1700	53						
					65	2050	64						
80	145	36,3	25	31	60	1700	53	16	7	M 8	25	2,4	4200-080310-000000
					65	2050	64						
					70	2350	69						
85	155	43,3	30	38	60	2400	70	16	10	M 8	30	3,4	4200-085310-000000
					65	2450	72						
					70	2500	74						
90	155	43,3	30	38	65	2550	75	16	10	M 8	30	3,3	4200-090310-000000
					70	3200	91						
					75	3800	101						
95	170	48,3	34	43	65	2600	76	16	12	M 8	35	4,6	4200-095310-000000
					70	2800	94						
					75	3100	102						
100	170	48,3	34	43	70	3300	96	16	12	M 8	35	4,4	4200-100310-000000
					75	4000	107						
					80	4800	117						
110	185	55,4	39	49	75	3900	103	32	9	M 10	40	5,9	4200-110310-000000
					80	4800	119						
					85	5600	130						

* The shaft diameters d_w listed in the table are selected examples. For other shaft diameters d_w see the technical specifications on page 31.

three-part design
corrosion-resistant in stainless steel

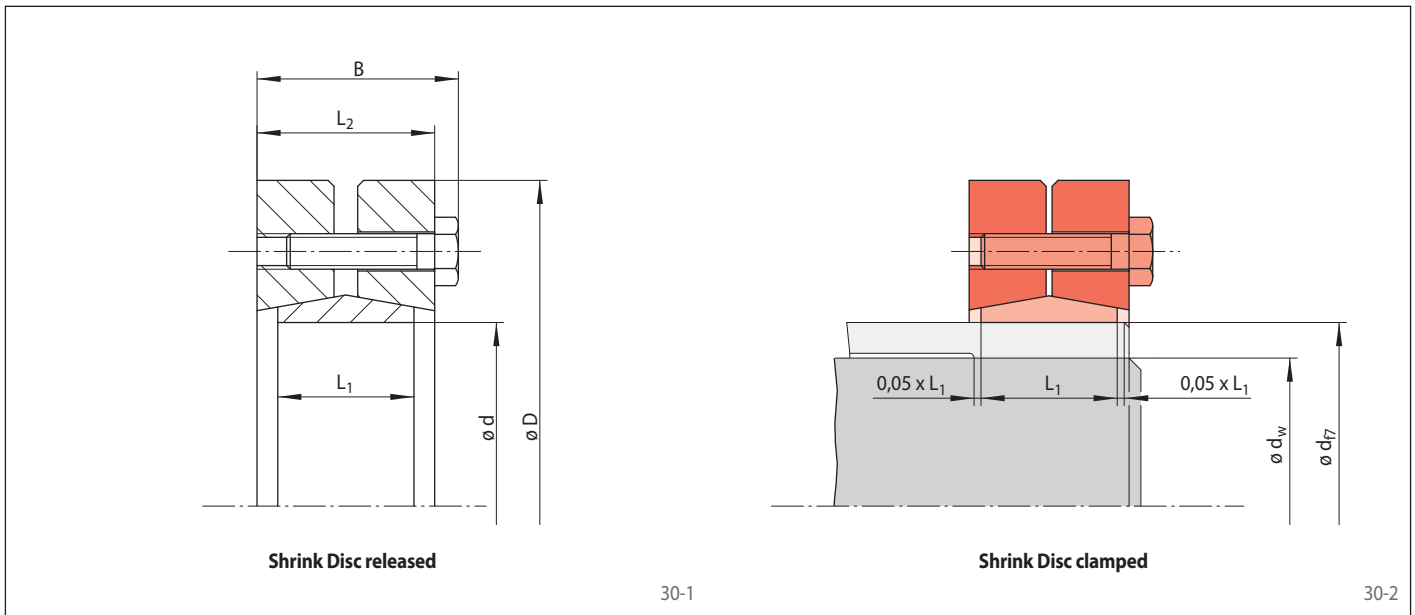

Dimensions						Technical Data							Article number
Size d mm	D mm	B mm	L ₁ mm	L ₂ mm	d _w * mm	Transmissible torque or axial force		Clamping screws				Weight kg	
						M Nm	F kN	Tightening torque M _s Nm	Number	Size	Length mm		
125	215	59,4	42	53	85	5 900	136	32	12	M 10	40	8,7	4200-125310-000000
					90	7 000	152						
					95	8 100	168						
130	215	59,4	42	53	90	6 500	141	32	12	M 10	40	8,4	4200-130310-000000
					95	7 800	163						
					100	9 200	184						
140	230	65,5	46	58	95	8 100	171	55	10	M 12	45	10,0	4200-140310-000000
					100	9 300	187						
					105	11 000	209						
165	290	78,0	56	68	115	17 000	292	135	8	M 16	55	21,0	4200-165310-000000
					120	19 000	319						
					125	21 000	346						
175	300	78,0	56	68	125	18 500	297	135	8	M 16	55	21,0	4200-175310-000000
					130	21 000	319						
					135	23 000	346						

* The shaft diameters d_w listed in the table are selected examples. For other shaft diameters d_w see the technical specifications on page 31.

Shaft diameter d_w

The values for the transmissible torques M or axial forces F given in the tables are calculated for exemplary shaft diameters d_w . Values for shaft diameter d_w that fall between the shaft

diameters d_w stated in the table can be determined with sufficient accuracy by interpolation. Please contact us for shaft diameters d_w which are smaller than those

given in the tables. We will gladly calculate the transmissible torques M or axial forces F for you.

Axial width of contact surface L_F

The transmission of torque or axial force is achieved through the contact surface between shaft and hollow shaft. The pressure created by the Shrink Disc decreases strongly in areas that go beyond the bearing axial width L_1 of the Shrink Disc. In such areas with low pressure, there may be micro movements that allow the formation of harmful fretting corrosion.

The axial width of contact surface L_F should therefore be limited to:

$$L_F \leq 1,1 \cdot L_1$$

For contact surfaces with a width that is smaller than L_1 , there is an increased pressure generated which may damage the shaft and/or hollow shaft or the hub. Please contact us.

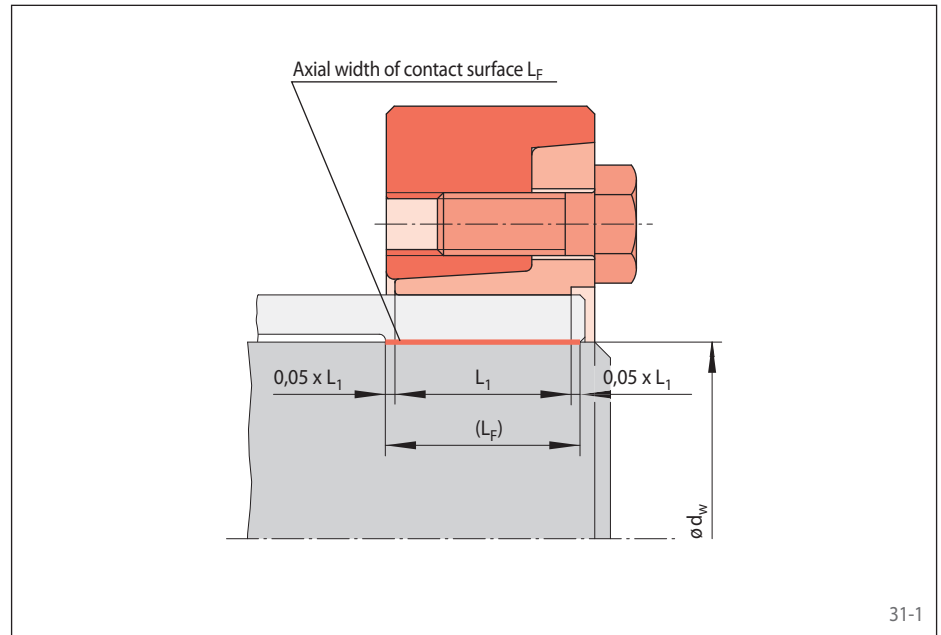

31-1

Joint clearance between shaft and hollow shaft

When the joint clearance exceeds the value given in the tables, the transmissible torque or the transmissible axial force decreases. Additionally, the equivalent stress in the hollow shaft increases in this case. Please contact us.

If the joint clearance is lower than indicated, the Shrink Disc, shaft or hollow shaft may be damaged during assembly or the torque listed in the tables can no longer be transmitted. Please contact us.

Formula symbols

d_w = Shaft diameter / inner diameter of hollow shaft according to table [mm]

F = Transmissible axial force according to table [kN]

F_A = Maximum actual application axial force [kN]

F_{red} = Reduced axial force [kN]

L_1 = Load-bearing axial width of Shrink Disc according to table [mm]

L_F = Axial width of contact surface [mm]

M = Transmissible torque according to table [Nm]

M_A = Maximum actual application torque [Nm]

M_{red} = Reduced torque [Nm]

μ = Friction value

Friction value

The values listed in the tables for transmissible torques M or axial forces F assume a friction value of $\mu=0,15$ in the contact surface between shaft and hollow shaft. This value is safely achieved in a dry and degreased steel/steel pairing.

For different friction values, the transmissible torque or axial force will change proportionally.

Simultaneous transmission of torque and axial force

The transmissible torques M which are shown in the tables apply for axial forces $F = 0$ kN and conversely, the indicated axial forces F apply to torques $M = 0$ Nm. If torque and axial force are to be transmitted simultaneously, the transmissible torque and the transmissible axial force are reduced compared to the values listed in the tables for M and F .

For a given axial force F_A or torque M_A , the reduced torque M_{red} or axial force F_{red} is calculated as:

$$M_{red} = \sqrt{M^2 - (F_A \cdot \frac{d_w}{2})^2}$$

or

$$F_{red} = \frac{2}{d_w} \sqrt{M^2 - M_A^2}$$

Cone Clamping Elements as shown in figure 32-1 consist of an outer ring with inside cone and an inner ring with outside cone as well as a number of clamping screws.

The outer ring is pulled onto the inner ring by tightening the clamping screws. Radial clamping forces are generated by the conical surfaces which are dependent on the torques of the clamping screws, the cone angle and the friction coefficients at the screws and conical surfaces.

The radial clamping forces press the outer ring into the hub bore and the inner ring onto the shaft and create a frictional connection at the respective contact surfaces. In this way, torque and/or axial force can be transmitted between the shaft and the hub.

In the configuration shown in the illustration, the connection is released by turning some of the clamping screws into the threaded bores for the jacking screws. This presses off the outer ring.

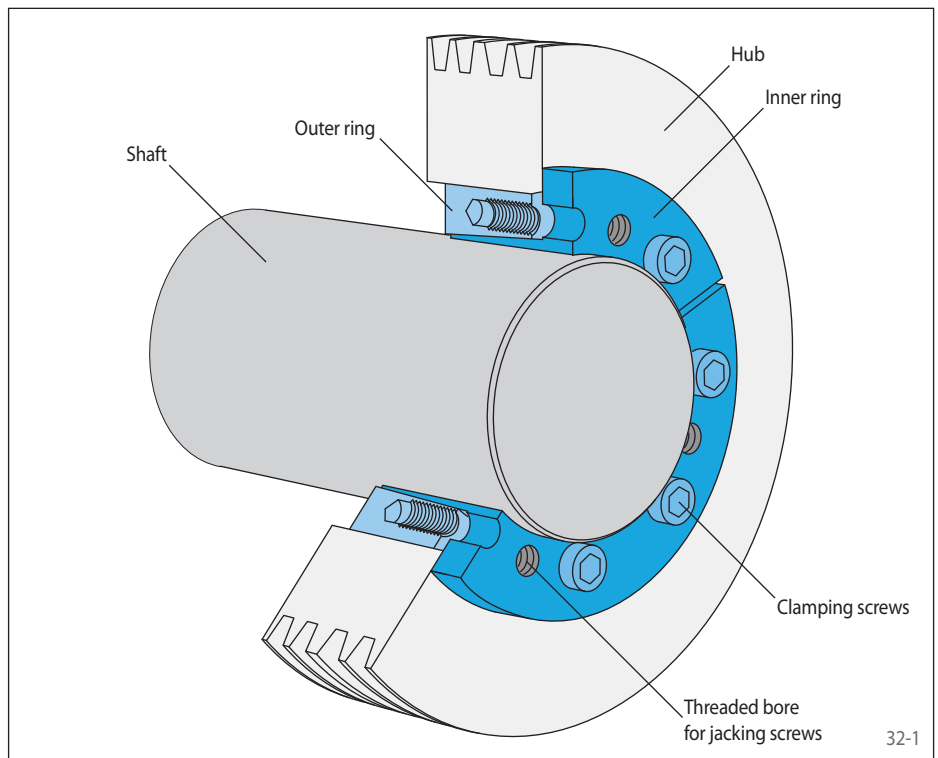

Centring the hub to the shaft

As a rule, a true running accuracy of the hub to the shaft of 0,02 to 0,04 mm can be achieved with Cone Clamping Elements. Exceptions are the Cone Clamping Elements of the series RLK 200 and RLK 300. With these series the hub must be centred to the shaft in accordance with the specific requirements of the application.

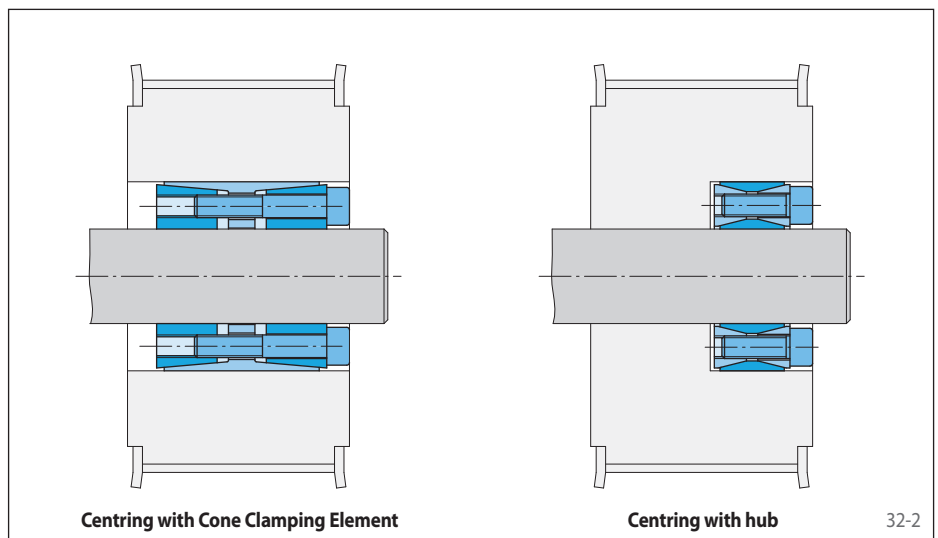

No axial displacement of the hub relative to the shaft during clamping

The overview on pages 4 and 5 shows the series for which no axial displacement of the hub relative to the shaft is created during the clamping procedure. This is ensured, for example, by a fixed hub backstop point on the collar of the inner ring. For all other series, the clamping procedure (tightening the clamping screws and pulling the outer ring onto the inner ring) involves an axial hub displacement.

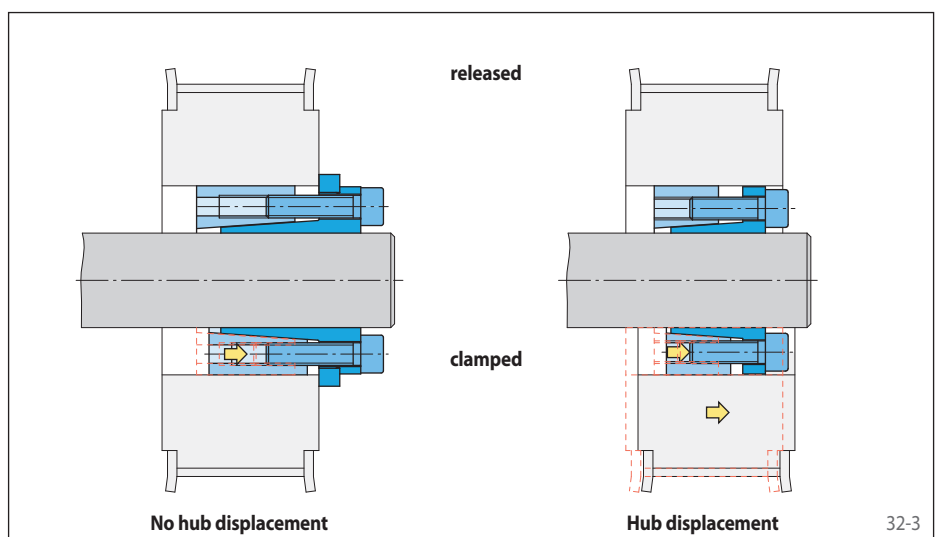

Frictional shaft-hub-connections with Cone Clamping Elements create very high radial clamping forces. This requires a hardness analysis of shaft and hub. For this, the Cone Clamping Element tables list the maximum pressures P_w in the contact surface at the shaft and the maximum pressures P_N in the contact surface at the hub.

The contact pressure P_w leads to radial stress in the shaft that is usually not critical for steel shafts. There is always a tangential stress σ_t in the hub, and for thin-walled hubs it may be a multiple of the initiated pressure P_N . The amount of the actual tangential stress depends on the hub width, the hub outer diameter and the pressure. Calculation of required hub width N_{min} takes into account the fact that hub pressure P_N is transmitted by load-bearing hub width L_1 and taken up beyond it in an angle of approximately $26,5^\circ$ (see figure 33-1).

For the different Cone Clamping Element series, the tables list the required hub width N_{min} and the required hub outer diameter K_{min} for three exemplary yield strengths R_e of the hub. Thereby, the hub is to be arranged as seen in figure 33-2 for Cone Clamping Elements with a fixed backstop point.

For any deviating hub arrangement and/or lower yield strengths R_e of the hub material, the shaft-hub-connection must be verified according to the technical points on pages 74 and 75.

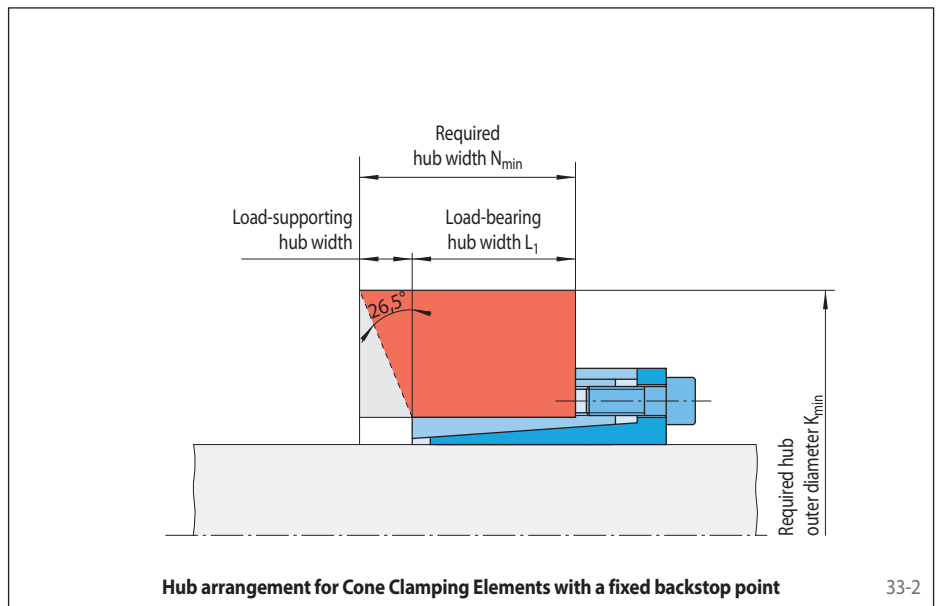
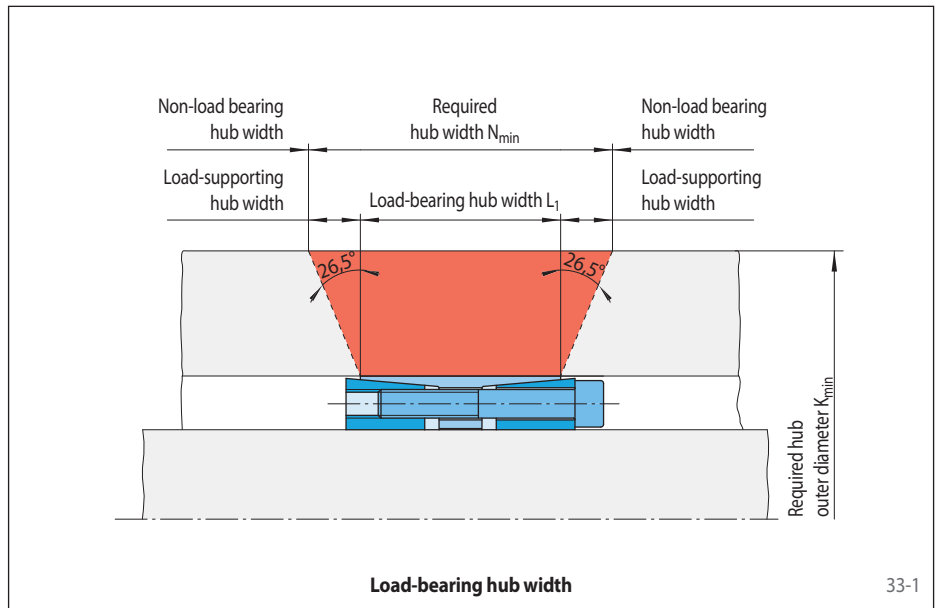

Cone Clamping Elements RLK 110

centres the hub to the shaft
radial flat height



Features

- Centres the shaft to the hub
- High transmissible torques
- Radial flat height is particularly suitable for small hub outer diameters
- No axial displacement between hub and shaft during clamping procedure due to fixed backstop point
- Transmissible torque of 17 Nm up to 18000 Nm
- For shaft diameters between 6 mm and 120 mm

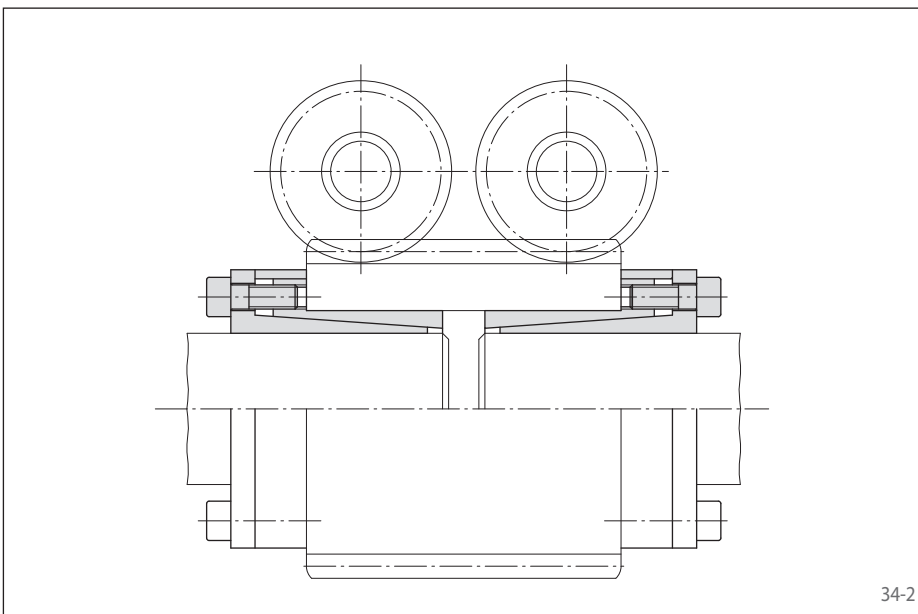

Application example

Backlash free connection of a screw gear and simultaneous coupling of the divided drive shaft of a continuous heating furnace with two Cone Clamping Elements RLK 110. A simple and cost-effective solution, because clamping the screw gear and coupling the shaft ends is achieved simultaneously by the Cone Clamping Elements.

Transmissible torques and axial forces

The transmissible torques or axial forces listed on the following page are subject to the following tolerances, surface characteristics and material requirements. Please contact us in the case of deviations.

Tolerances

- h8 for shaft diameter d
- H8 for hub bore D

Surfaces

Average surface roughness at the contact surfaces between the shaft and the hub bore:
 $R_z = 10 \dots 25 \mu\text{m}$.

Materials

The following apply to the shaft and the hub:

- E-module $\geq 170 \text{ kN/mm}^2$

Installation

Please request our installation and operating instructions for Cone Clamping Elements RLK 110.

Simultaneous transmission of torque and axial force

The transmissible torques M which are shown in the tables apply for axial forces $F = 0 \text{ kN}$ and conversely, the indicated axial forces F apply to torques $M = 0 \text{ Nm}$. If torque and axial force are to be transmitted simultaneously, the transmissible torque and the transmissible axial force are reduced. Please refer to the technical points on pages 74 and 75.

Example for ordering

Cone Clamping Element RLK 110 for shaft diameter $d = 100 \text{ mm}$:

- RLK 110, size 100 x 125
Article number 4206-100001-000000

centres the hub to the shaft
radial flat height

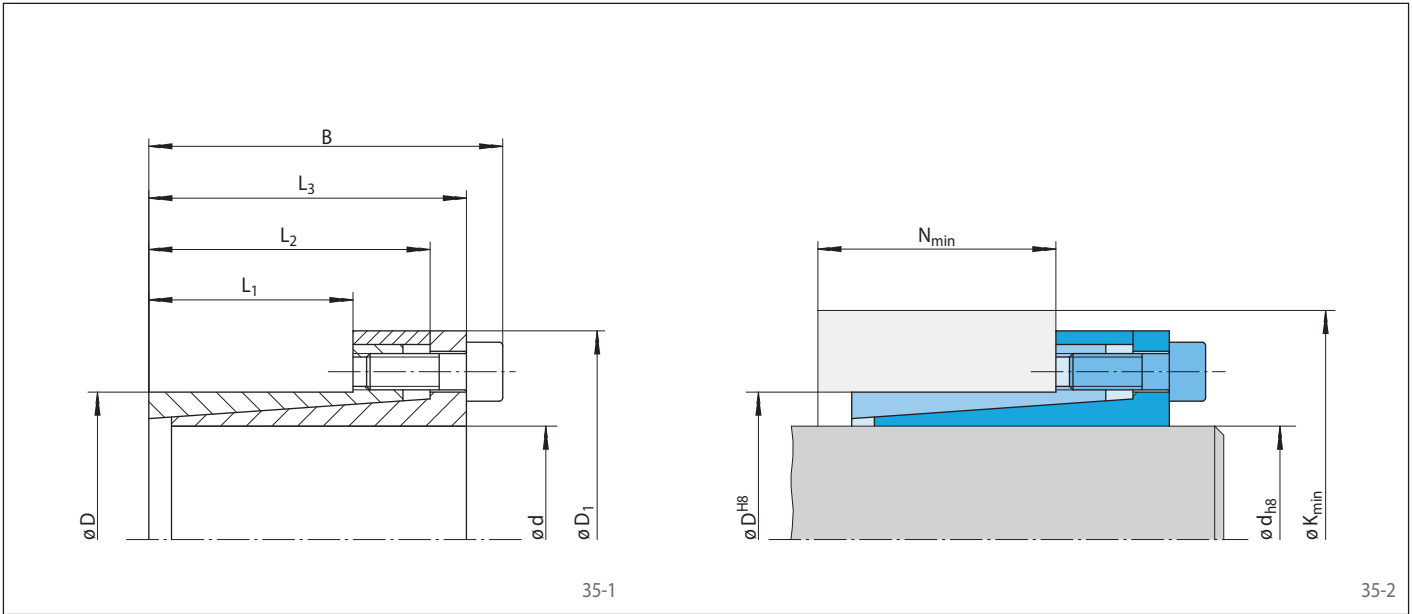

Dimensions														Technical Data								Article number
Size		Yield strength R_e of the hub material [N/mm ²]												Transmissible torque or axial force		Contact pressure at		Clamping screws			Weight	
d mm	D mm	200			320			500			M	F	Shaft P_W	Hub P_N	Tightening torque M_5	Number	Size	Length	kg			
mm	mm	D_1	B	L_1	L_2	L_3	K_{min}	N_{min}	K_{min}	N_{min}	K_{min}	N_{min}	Nm	kN	N/mm ²	N/mm ²	Nm		mm			
6	14	25	24	10	19	21	33	15	23	13	19	12	17	5,8	255	110	2,1	4	M 3	10	0,1	4206-006001-000000
8	15	27	29	12	22	25	38	18	26	15	21	14	31	7,8	216	115	5,1	3	M 4	10	0,1	4206-008001-000000
9	16	28	30	14	23	26	45	22	29	18	23	16	47	10	219	123	5,1	4	M 4	10	0,1	4206-009001-000000
10	16	29	30	14	23	26	45	22	29	18	23	16	52	10	197	123	5,1	4	M 4	10	0,2	4206-010001-000000
11	18	32	30	14	23	26	43	21	30	17	25	16	57	10	179	110	5,1	4	M 4	10	0,2	4206-011001-000000
12	18	32	30	14	23	26	43	21	30	17	25	16	62	10	164	110	5,1	4	M 4	10	0,2	4206-012001-000000
14	23	38	30	14	23	26	42	19	33	17	29	16	73	10	141	86	5,1	4	M 4	10	0,2	4206-014001-000000
15	24	44	42	16	29	36	84	31	52	23	38	20	180	24	261	164	17,4	4	M 6	18	0,2	4206-015001-000000
16	24	44	42	16	29	36	84	31	52	23	38	20	190	24	245	164	17,4	4	M 6	18	0,3	4206-016001-000000
17	26	47	44	18	31	38	75	31	49	24	38	21	200	24	205	134	17,4	4	M 6	18	0,3	4206-017001-000000
18	26	47	44	18	31	38	75	31	49	24	38	21	210	24	194	134	17,4	4	M 6	18	0,3	4206-018001-000000
19	27	48	44	18	31	38	73	30	49	24	39	21	220	24	184	129	17,4	4	M 6	18	0,3	4206-019001-000000
20	28	49	44	18	31	38	72	29	49	24	40	21	240	24	174	125	17,4	4	M 6	18	0,3	4206-020001-000000
22	32	54	51	25	38	45	58	32	45	29	40	27	260	24	114	79	17,4	4	M 6	18	0,3	4206-022001-000000
24	34	56	51	25	38	45	59	32	47	29	42	27	280	24	105	74	17,4	4	M 6	18	0,3	4206-024001-000000
25	34	56	51	25	38	45	59	32	47	29	42	27	300	24	101	74	17,4	4	M 6	18	0,3	4206-025001-000000
28	39	61	51	25	38	45	80	36	60	31	51	28	500	35	135	97	17,4	6	M 6	18	0,4	4206-028001-000000
30	41	62	51	25	38	45	80	35	61	30	53	28	530	35	126	92	17,4	6	M 6	18	0,4	4206-030001-000000
32	43	65	51	25	38	45	100	40	71	32	59	29	760	47	157	117	17,4	8	M 6	18	0,5	4206-032001-000000
35	47	69	56	30	43	50	90	41	69	36	60	34	830	47	120	89	17,4	8	M 6	18	0,5	4206-035001-000000
38	50	72	56	30	43	50	91	41	71	36	63	34	900	47	110	84	17,4	8	M 6	18	0,6	4206-038001-000000
40	53	75	56	30	43	50	92	40	74	36	65	33	940	47	105	79	17,4	8	M 6	18	0,6	4206-040001-000000
42	55	78	65	32	50	57	142	54	97	43	78	38	1800	86	171	130	42,2	8	M 8	22	0,9	4206-042001-000000
45	59	85	73	40	57	65	122	56	90	48	77	45	1950	86	128	97	42,2	8	M 8	22	1,0	4206-045001-000000
48	62	87	78	45	62	70	114	58	89	52	78	49	2050	86	106	82	42,2	8	M 8	22	1,0	4206-048001-000000
50	65	92	78	45	62	70	136	63	100	54	85	50	2700	110	128	98	42,2	10	M 8	22	1,3	4206-050001-000000
55	71	98	83	50	67	75	129	65	101	58	88	55	3000	110	104	81	42,2	10	M 8	22	1,5	4206-055001-000000
60	77	104	83	50	67	75	131	64	106	58	94	55	3200	110	96	75	42,2	10	M 8	22	1,7	4206-060001-000000
65	84	111	83	50	67	75	135	63	112	57	101	55	3500	110	88	69	42,2	10	M 8	22	1,9	4206-065001-000000
70	90	119	101	60	80	91	166	79	129	70	113	66	5900	170	108	84	83,0	10	M 10	25	2,9	4206-070001-000000
75	95	126	101	60	80	91	168	79	133	70	117	66	6400	170	101	80	83,0	10	M 10	25	2,3	4206-075001-000000
80	100	131	106	65	85	96	184	86	143	76	125	72	8200	200	104	84	83,0	12	M 10	25	3,3	4206-080001-000000
85	106	137	106	65	85	96	186	85	148	76	131	72	8700	200	98	79	83,0	12	M 10	25	3,6	4206-085001-000000
90	112	143	106	65	85	96	218	92	167	79	143	73	11500	250	116	93	83,0	15	M 10	25	4,0	4206-090001-000000
95	120	153	106	65	85	96	219	90	173	79	151	73	12100	250	110	87	83,0	15	M 10	25	4,5	4206-095001-000000
100	125	162	114	65	89	102	245	95	188	81	161	74	15000	300	123	98	144,0	12	M 12	30	5,5	4206-100001-000000
110	140	180	140	90	114	128	217	110	182	101	165	97	16500	300	81	64	144,0	12	M 12	30	8,0	4206-110001-000000
120	155	198	140	90	114	128	228	109	196	101	180	97	18000	300	74	57	144,0	12	M 12	30	10,5	4206-120001-000000

Cone Clamping Elements RLK 110 K

centres the hub to the shaft
corrosion protected



36-1

Features

- Centres the shaft to the hub
- All parts 35 µm chemically nickel-coated for high corrosion resistance pursuant to DIN 50021 (neutral salt spray test)
- High transmissible torques
- Radial flat height is particularly suitable for small hub outer diameters
- No axial displacement between hub and shaft during clamping procedure due to fixed backstop point
- Transmissible torque of 190 Nm up to 2800 Nm
- For shaft diameters between 19 mm and 60 mm

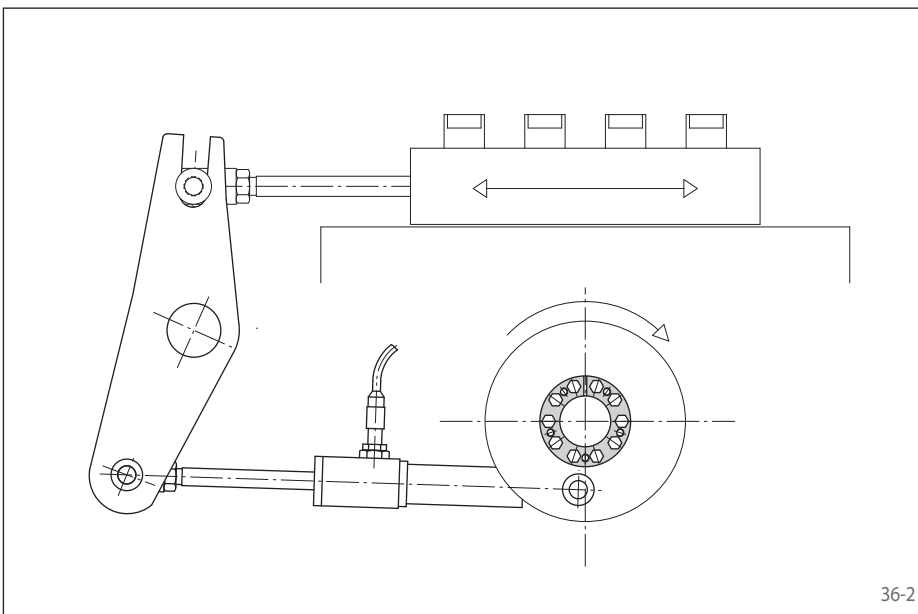

36-2

Application example

Backlash free connection of an eccentric wheel to the drive shaft of a packaging machine with a Cone Clamping Element RLK 110 K. The turning motion is transmitted into translatory motion by a driving rod that is protected from overload by a RINGSPANN force limiter.

Transmissible torques and axial forces

The transmissible torques or axial forces listed on the following page are subject to the following tolerances, surface characteristics and material requirements. Please contact us in the case of deviations.

Tolerances

- h8 for shaft diameter d
- H8 for hub bore D

Surfaces

Average surface roughness at the contact surfaces between the shaft and the hub bore:
 $R_z = 10 \dots 25 \mu\text{m}$.

Materials

The following apply to the shaft and the hub:

- E-module $\geq 170 \text{ kN/mm}^2$

Installation

Please request our installation and operating instructions for Cone Clamping Elements RLK 110 K.

Simultaneous transmission of torque and axial force

The transmissible torques M which are shown in the tables apply for axial forces $F = 0 \text{ kN}$ and conversely, the indicated axial forces F apply to torques $M = 0 \text{ Nm}$. If torque and axial force are to be transmitted simultaneously, the transmissible torque and the transmissible axial force are reduced. Please refer to the technical points on pages 74 and 75.

Example for ordering

Cone Clamping Element RLK 110 K for shaft diameter $d = 50 \text{ mm}$:

- RLK 110 K, size 50 x 65
Article number 4206-050001-A08101

centres the hub to the shaft
corrosion protected

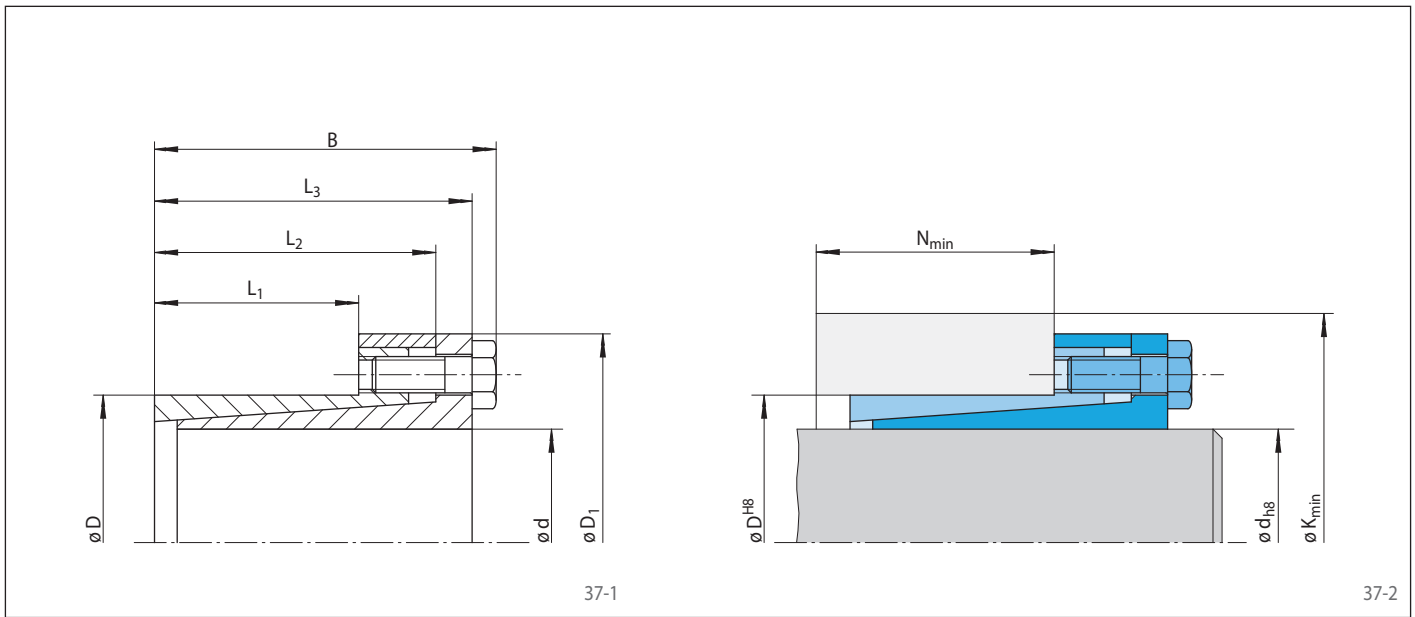

Dimensions							Technical Data														Article number	
Size		D ₁ mm	B mm	L ₁ mm	L ₂ mm	L ₃ mm	Yield strength R _e of the hub material [N/mm ²]				Transmissible torque or axial force		Contact pressure at		Clamping screws			Weight kg				
d mm	D mm						200	320	500	M	F	Shaft P _w N/mm ²	Hub P _N N/mm ²	Tightening torque M ₅ Nm	Num- ber	Size	Length mm					
19	27	49	41	18	31	38	62	27	44	23	37	21	190	20	157	111	14,9	4	M 6	18	0,3	4206-019001-A08101
20	28	49	41	18	31	38	62	27	45	23	38	21	200	20	149	107	14,9	4	M 6	18	0,3	4206-020001-A08101
22	32	54	48	25	38	45	52	30	43	28	39	27	220	20	98	67	14,9	4	M 6	18	0,3	4206-022001-A08101
25	34	56	48	25	38	45	54	30	45	28	41	27	250	20	86	63	14,9	4	M 6	18	0,4	4206-025001-A08101
28	39	61	49	25	38	45	71	33	56	30	49	28	420	30	115	83	14,9	6	M 6	18	0,5	4206-028001-A08101
30	41	62	49	25	38	45	71	33	57	29	51	28	450	30	108	79	14,9	6	M 6	18	0,5	4206-030001-A08101
32	43	65	56	30	43	50	79	39	62	35	54	33	650	40	112	83	14,9	8	M 6	18	0,5	4206-032001-A08101
35	47	69	56	30	43	50	81	39	65	35	58	33	710	40	102	76	14,9	8	M 6	18	0,6	4206-035001-A08101
38	50	72	56	30	43	50	82	38	68	35	61	33	770	40	94	72	14,9	8	M 6	18	0,6	4206-038001-A08101
40	53	75	56	30	43	50	84	38	70	35	63	33	810	40	90	68	14,9	8	M 6	18	0,7	4206-040001-A08101
45	59	85	71	40	57	65	108	53	84	47	74	44	1650	74	109	83	36,1	8	M 8	22	1,2	4206-045001-A08101
50	65	92	76	45	62	70	120	59	93	52	82	50	2300	92	109	84	36,1	10	M 8	22	1,3	4206-050001-A08101
55	71	98	81	50	67	75	117	62	95	56	85	54	2500	92	89	69	36,1	10	M 8	22	1,5	4206-055001-A08101
60	77	104	81	50	67	75	120	61	101	56	91	54	2800	92	82	64	36,1	10	M 8	22	1,7	4206-060001-A08101

Cone Clamping Elements RLK 130

centres the hub to the shaft
very high transmissible torques

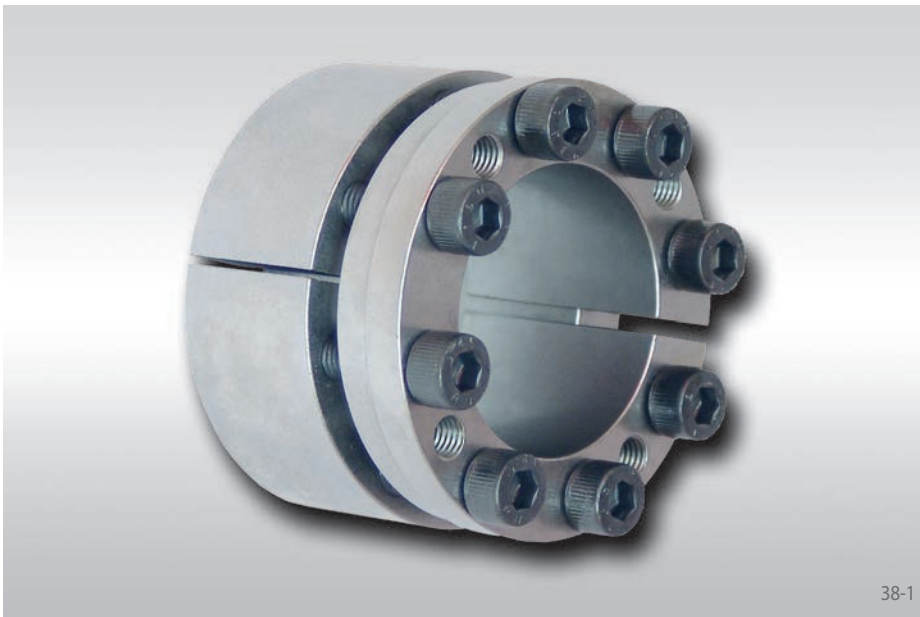

38-1

Features

- Centres the shaft to the hub
- Very high transmissible torques
- Transmissible torque of 580 Nm up to 70 000 Nm
- For shaft diameters between 20 mm and 180 mm

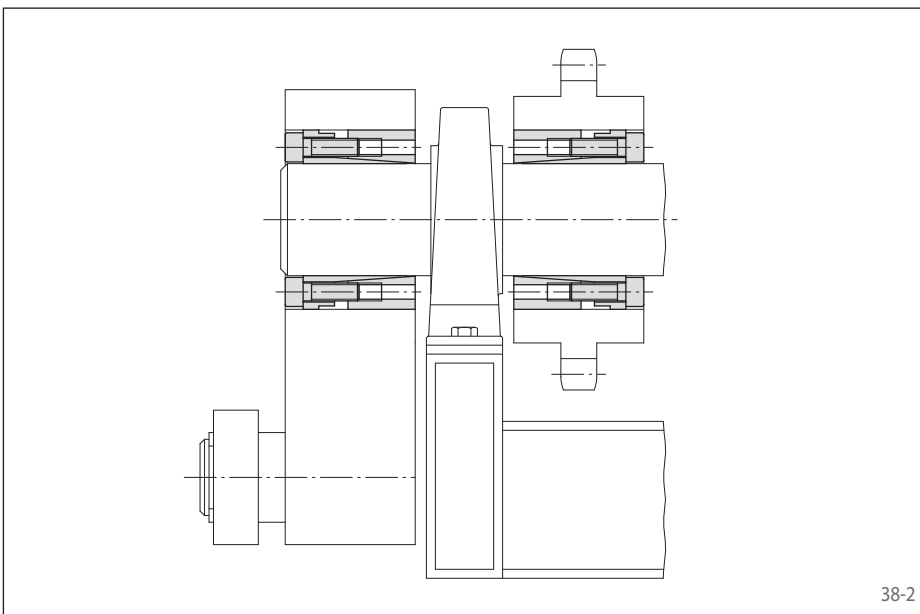

38-2

Application example

Backlash free connection of an eccentric lift unit and a sprocket to the drive shaft of a hoisting device using Cone Clamping Elements RLK 130. The eccentric force applied to the eccentric lift unit results in the Cone Clamping Element transmitting not only torque, but also forces and bending moments.

Transmissible torques and axial forces

The transmissible torques or axial forces listed on the following page are subject to the following tolerances, surface characteristics and material requirements. Please contact us in the case of deviations.

Tolerances

- h8 for shaft diameter d
- H8 for hub bore D

Surfaces

Average surface roughness at the contact surfaces between the shaft and the hub bore:
 $R_z = 10 \dots 25 \mu\text{m}$.

Materials

The following apply to the shaft and the hub:

- E-module $\geq 170 \text{ kN/mm}^2$

Installation

Please request our installation and operating instructions for Cone Clamping Elements RLK 130.

Simultaneous transmission of torque and axial force

The transmissible torques M which are shown in the tables apply for axial forces $F = 0 \text{ kN}$ and conversely, the indicated axial forces F apply to torques $M = 0 \text{ Nm}$. If torque and axial force are to be transmitted simultaneously, the transmissible torque and the transmissible axial force are reduced. Please refer to the technical points on pages 74 and 75.

Example for ordering

Cone Clamping Element RLK 130 for shaft diameter $d = 100 \text{ mm}$:

- RLK 130, size 100 x 145
Article number 4204-100001-000000

centres the hub to the shaft
very high transmissible torques

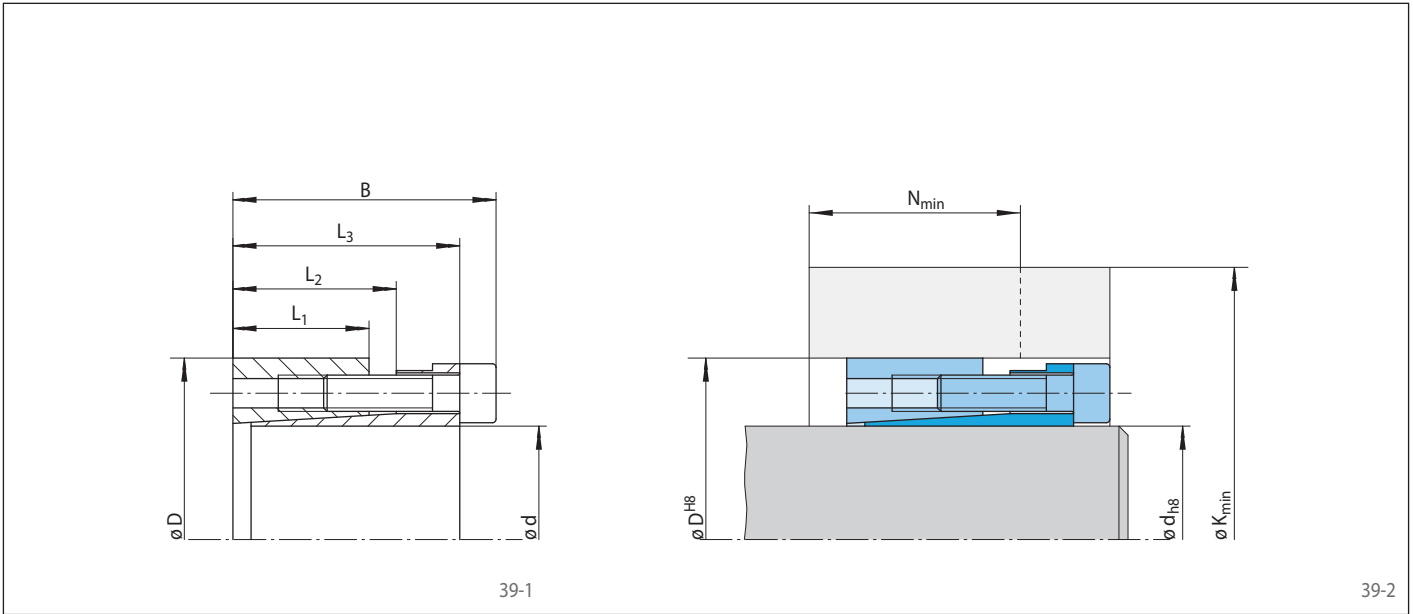

Dimensions												Technical Data										Article number
Size		B mm	L ₁ mm	L ₂ mm	L ₃ mm	Yield strength R _e of the hub material [N/mm ²]						Transmissible torque or axial force		Contact pressure at		Clamping screws			Weight kg			
d mm	D mm					200	320	500	M	F	P _w N/mm ²	P _N N/mm ²	Tightening torque M ₅ Nm	Num- ber	Size	Length mm						
20	47	48	26	31	42	92	49	73	39	63	34	580	58	294	126	17,4	6	M 6	25	0,4	4204-020001-000000	
22	47	48	26	31	42	92	49	73	39	63	34	630	58	268	126	17,4	6	M 6	25	0,4	4204-022001-000000	
24	50	48	26	31	42	93	48	76	39	66	34	690	58	245	118	17,4	6	M 6	25	0,4	4204-024001-000000	
25	50	48	26	31	42	93	48	76	39	66	34	720	58	236	118	17,4	6	M 6	25	0,4	4204-025001-000000	
28	55	48	26	31	42	96	47	80	39	71	34	810	58	210	107	17,4	6	M 6	25	0,5	4204-028001-000000	
30	55	48	26	31	42	96	47	80	39	71	34	860	58	196	107	17,4	6	M 6	25	0,5	4204-030001-000000	
32	60	48	26	31	42	113	53	92	42	80	36	1250	77	245	131	17,4	8	M 6	25	0,5	4204-032001-000000	
35	60	48	26	31	42	113	53	92	42	80	36	1350	77	224	131	17,4	8	M 6	25	0,5	4204-035001-000000	
38	65	48	26	31	42	116	52	96	42	85	36	1450	77	207	121	17,4	8	M 6	25	0,6	4204-038001-000000	
40	65	48	26	31	42	116	52	96	42	85	36	1550	77	196	121	17,4	8	M 6	25	0,6	4204-040001-000000	
42	75	59	30	35	51	135	60	112	49	98	42	2200	110	222	125	42,2	6	M 8	30	1,0	4204-042001-000000	
45	75	59	30	35	51	135	60	112	49	98	42	2350	110	207	125	42,2	6	M 8	30	0,9	4204-045001-000000	
48	80	59	30	35	51	158	69	128	54	111	46	3400	140	259	156	42,2	8	M 8	30	1,1	4204-048001-000000	
50	80	59	30	35	51	158	69	128	54	111	46	3500	140	249	156	42,2	8	M 8	30	1,0	4204-050001-000000	
55	85	59	30	35	51	160	68	132	54	115	45	3900	140	226	146	42,2	8	M 8	30	1,1	4204-055001-000000	
60	90	59	30	35	51	163	67	135	53	119	45	4200	140	207	138	42,2	8	M 8	30	1,2	4204-060001-000000	
65	95	59	30	35	51	166	66	139	52	124	45	4600	140	191	131	42,2	8	M 8	30	1,2	4204-065001-000000	
70	110	70	40	45	60	201	86	166	68	146	58	7700	220	210	134	83,0	8	M 10	30	2,3	4204-070001-000000	
75	115	70	40	45	60	203	84	170	68	150	58	8300	220	196	128	83,0	8	M 10	30	2,5	4204-075001-000000	
80	120	70	40	45	60	206	83	174	67	155	58	8800	220	184	123	83,0	8	M 10	30	2,6	4204-080001-000000	
85	125	70	40	45	60	231	93	191	73	168	62	11700	280	216	147	83,0	10	M 10	30	2,7	4204-085001-000000	
90	130	70	40	45	60	233	92	195	73	172	61	12400	280	204	141	83,0	10	M 10	30	2,8	4204-090001-000000	
95	135	70	40	45	60	236	91	199	72	177	61	13000	280	193	136	83,0	10	M 10	30	3,2	4204-095001-000000	
100	145	80	45	52	68	253	99	213	79	189	67	16000	320	192	133	144,0	8	M 12	35	3,9	4204-100001-000000	
110	155	80	45	52	68	259	97	221	78	198	67	18000	320	175	124	144,0	8	M 12	35	4,8	4204-110001-000000	
120	165	80	45	52	68	290	108	245	85	218	72	24500	410	200	146	144,0	10	M 12	35	5,0	4204-120001-000000	
130	180	80	45	52	68	322	116	271	91	241	76	31500	490	221	160	144,0	12	M 12	35	6,0	4204-130001-000000	
140	190	90	50	58	76	341	126	286	98	254	82	39000	560	211	156	229,0	10	M 14	40	8,2	4204-140001-000000	
150	200	90	50	58	76	375	138	312	106	274	87	50000	670	236	177	229,0	12	M 14	40	8,7	4204-150001-000000	
160	210	90	50	58	76	380	135	320	105	283	87	53500	670	222	169	229,0	12	M 14	40	9,0	4204-160001-000000	
170	225	90	50	58	76	414	145	348	112	307	91	66000	780	243	184	229,0	14	M 14	40	10,0	4204-170001-000000	
180	235	90	50	58	76	420	143	356	111	316	91	70000	780	230	176	229,0	14	M 14	40	11,0	4204-180001-000000	

Cone Clamping Elements RLK 131

**centres the hub to the shaft
no axial displacement**

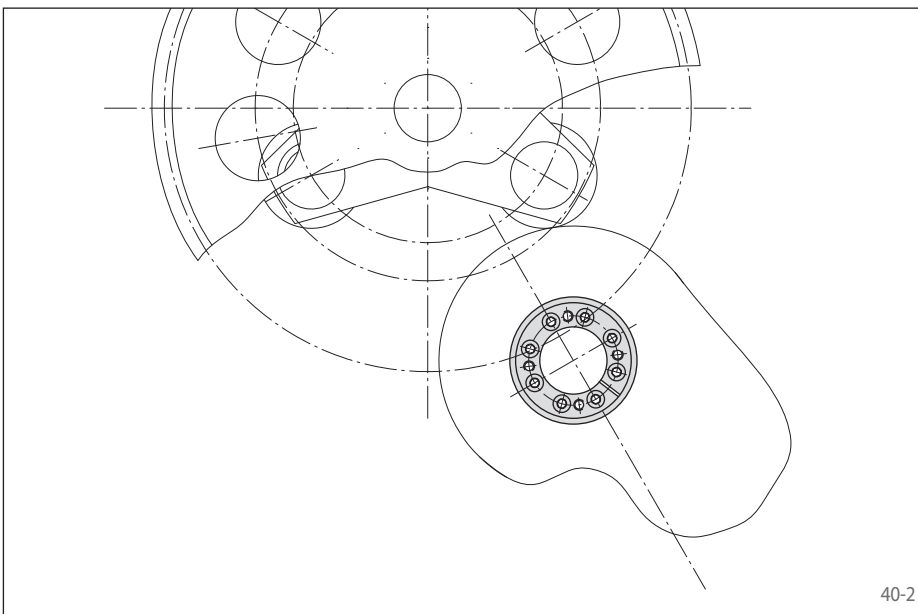
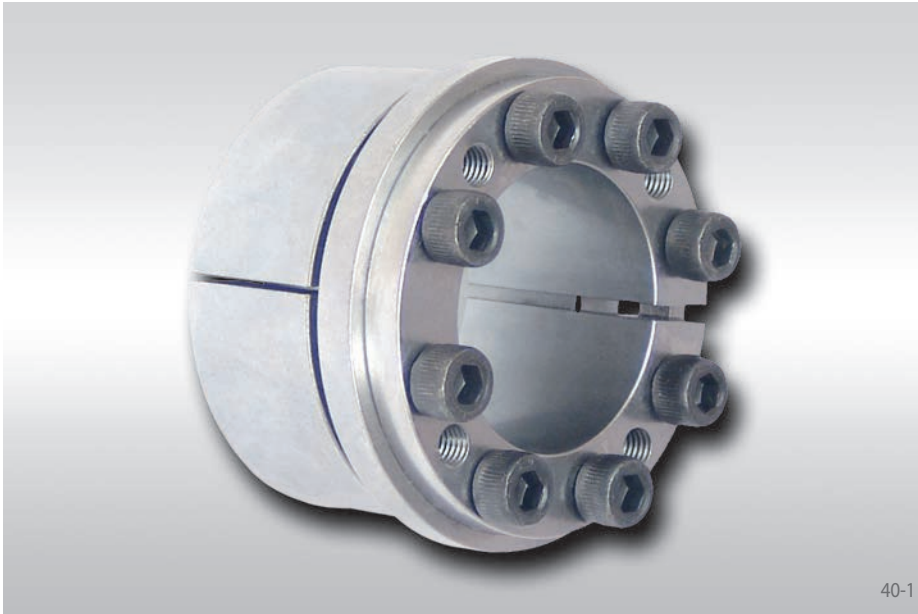

Features

- Centres the shaft to the hub
- No axial displacement between hub and shaft during clamping procedure due to fixed backstop point
- Transmissible torque of 350 Nm up to 43 000 Nm
- For shaft diameters between 20 mm and 180 mm

Application example

Backlash free connection of a cam disc to the drive shaft in a stepping gear in the material feed mechanism of a paper processing machine with a Cone Clamping Element RLK 131.

Transmissible torques and axial forces

The transmissible torques or axial forces listed on the following page are subject to the following tolerances, surface characteristics and material requirements. Please contact us in the case of deviations.

Tolerances

- h8 for shaft diameter d
- H8 for hub bore D

Surfaces

Average surface roughness at the contact surfaces between the shaft and the hub bore:
 $R_z = 10 \dots 25 \mu\text{m}$.

Materials

The following apply to the shaft and the hub:

- E-module $\geq 170 \text{ kN/mm}^2$

Installation

Please request our installation and operating instructions for Cone Clamping Elements RLK 131.

Simultaneous transmission of torque and axial force

The transmissible torques M which are shown in the tables apply for axial forces $F = 0 \text{ kN}$ and conversely, the indicated axial forces F apply to torques $M = 0 \text{ Nm}$. If torque and axial force are to be transmitted simultaneously, the transmissible torque and the transmissible axial force are reduced. Please refer to the technical points on pages 74 and 75.

Example for ordering

Cone Clamping Element RLK 131 for shaft diameter $d = 100 \text{ mm}$:

- RLK 131, size 100 x 145
Article number 4204-100101-000000

Cone Clamping Elements RLK 131

centres the hub to the shaft
no axial displacement

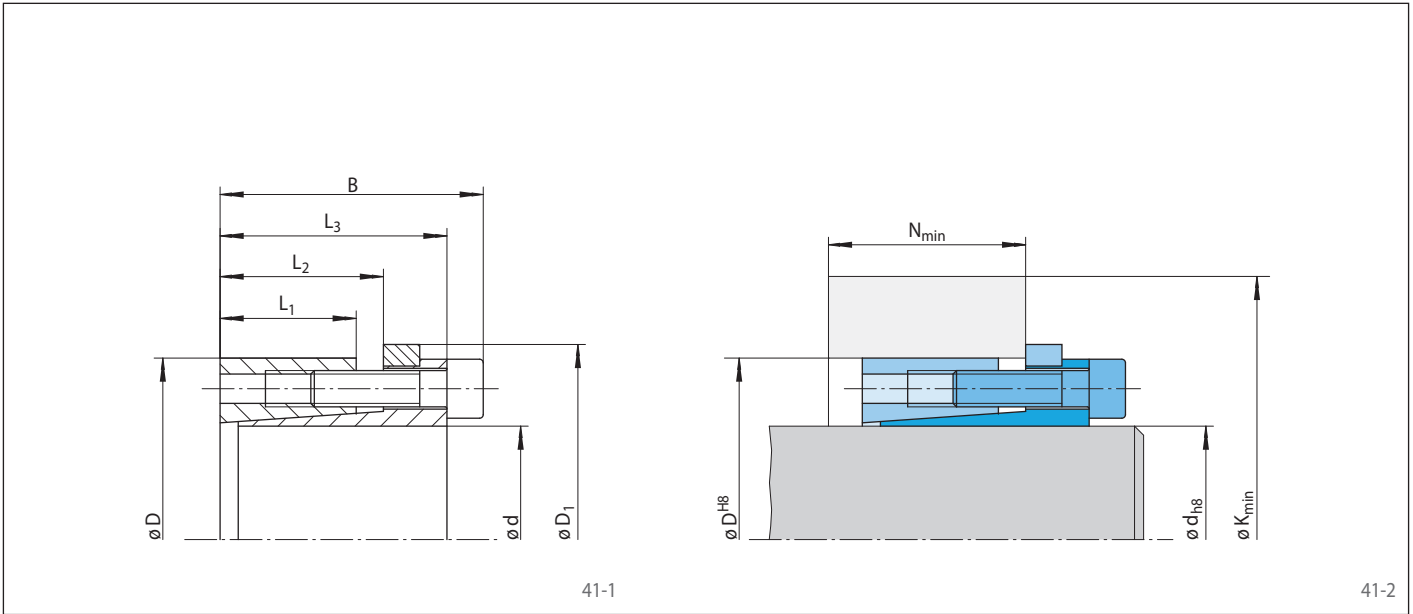

Dimensions													Technical Data										Article number
Size		Yield strength R_e of the hub material [N/mm ²]							Transmissible torque or axial force		Contact pressure at		Clamping screws			Weight							
d mm	D mm	200		320		500			M	F	Shaft P_W N/mm ²	Hub P_N N/mm ²	Tightening torque M_5 Nm	Number	Size		Length mm	kg					
20	47	53	48	26	31	42	80	35	65	31	58	29	350	35	181	77	17,4	6	M 6	25	0,4	4204-020101-000000	
22	47	53	48	26	31	42	80	35	65	31	58	29	390	35	165	77	17,4	6	M 6	25	0,4	4204-022101-000000	
24	50	56	48	26	31	42	82	34	68	31	61	29	430	35	151	73	17,4	6	M 6	25	0,4	4204-024101-000000	
25	50	56	48	26	31	42	82	34	68	31	61	29	440	35	145	73	17,4	6	M 6	25	0,4	4204-025101-000000	
28	55	61	48	26	31	42	85	34	72	31	65	29	500	35	130	66	17,4	6	M 6	25	0,5	4204-028101-000000	
30	55	61	48	26	31	42	85	34	72	31	65	29	530	35	121	66	17,4	6	M 6	25	0,5	4204-030101-000000	
32	60	66	48	26	31	42	101	37	83	32	74	30	760	47	151	81	17,4	8	M 6	25	0,6	4204-032101-000000	
35	60	66	48	26	31	42	101	37	83	32	74	30	830	47	138	81	17,4	8	M 6	25	0,5	4204-035101-000000	
38	65	71	48	26	31	42	104	36	87	32	79	30	900	47	127	75	17,4	8	M 6	25	0,6	4204-038101-000000	
40	65	71	48	26	31	42	104	36	87	32	79	30	940	47	121	75	17,4	8	M 6	25	0,6	4204-040101-000000	
42	75	81	59	30	35	51	121	42	101	37	91	34	1350	65	137	77	42,2	6	M 8	30	1,1	4204-042101-000000	
45	75	81	59	30	35	51	121	42	101	37	91	34	1450	65	128	77	42,2	6	M 8	30	1,1	4204-045101-000000	
48	80	86	59	30	35	51	144	46	116	39	102	36	2050	86	159	96	42,2	8	M 8	30	1,1	4204-048101-000000	
50	80	86	59	30	35	51	144	46	116	39	102	36	2150	86	153	96	42,2	8	M 8	30	1,1	4204-050101-000000	
55	85	91	59	30	35	51	146	46	120	39	106	36	2350	86	139	90	42,2	8	M 8	30	1,2	4204-055101-000000	
60	90	96	59	30	35	51	149	45	124	39	111	36	2600	86	128	85	42,2	8	M 8	30	1,3	4204-060101-000000	
65	95	101	59	30	35	51	152	45	129	39	116	36	2800	86	118	81	42,2	8	M 8	30	1,3	4204-065101-000000	
70	110	119	70	40	45	60	182	58	151	51	135	47	4800	140	129	82	83,0	8	M 10	30	2,4	4204-070101-000000	
75	115	124	70	40	45	60	185	58	156	51	140	47	5100	140	121	79	83,0	8	M 10	30	2,6	4204-075101-000000	
80	120	129	70	40	45	60	189	58	160	50	145	47	5400	140	113	76	83,0	8	M 10	30	2,7	4204-080101-000000	
85	125	134	70	40	45	60	213	62	176	53	156	48	7200	170	133	91	83,0	10	M 10	30	2,8	4204-085101-000000	
90	130	139	70	40	45	60	216	62	180	53	161	48	7600	170	126	87	83,0	10	M 10	30	3,0	4204-090101-000000	
95	135	144	70	40	45	60	219	61	184	53	166	48	8100	170	119	84	83,0	10	M 10	30	3,2	4204-095101-000000	
100	145	155	80	45	52	68	233	67	196	58	177	53	10000	200	118	82	144,0	8	M 12	35	4,1	4204-100101-000000	
110	155	165	80	45	52	68	240	67	205	58	186	53	11000	200	108	76	144,0	8	M 12	35	4,4	4204-110101-000000	
120	165	175	80	45	52	68	271	72	228	61	204	55	15000	250	123	90	144,0	10	M 12	35	4,7	4204-120101-000000	
130	180	188	80	45	52	68	304	76	254	64	226	57	19500	300	136	99	144,0	12	M 12	35	5,7	4204-130101-000000	
140	190	199	90	50	58	76	320	83	267	70	238	62	24000	340	130	96	229,0	10	M 14	40	6,9	4204-140101-000000	
150	200	209	90	50	58	76	355	89	292	73	257	65	31000	410	146	109	229,0	12	M 14	40	7,2	4204-150101-000000	
160	210	219	90	50	58	76	360	88	300	73	266	64	33000	410	136	104	229,0	12	M 14	40	7,8	4204-160101-000000	
170	225	234	90	50	58	76	396	93	328	76	290	67	40500	480	150	113	229,0	14	M 14	40	8,9	4204-170101-000000	
180	235	244	90	50	58	76	402	92	336	76	299	66	43000	480	142	109	229,0	14	M 14	40	9,5	4204-180101-000000	

Cone Clamping Elements RLK 132

centres the hub to the shaft
short axial width



42-1

Features

- Centres the shaft to the hub
- High transmissible torques
- Short axial width
- Transmissible torque of 580 Nm up to 83 500 Nm
- For shaft diameters between 20 mm and 200 mm

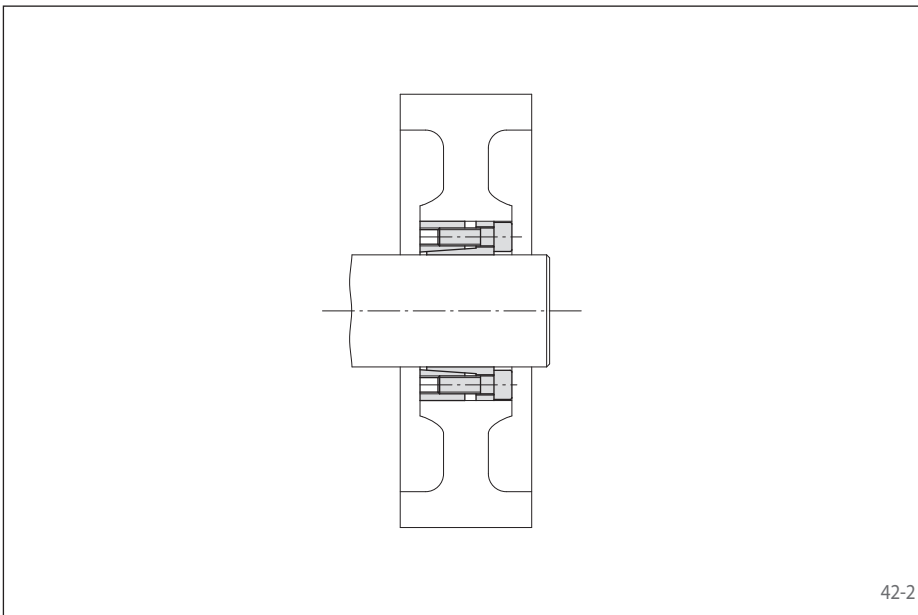

42-2

Application example

Backlash free connection of a belt pulley to the drive shaft with a Cone Clamping Element RLK 132. The Cone Clamping Element also centres the pulley to the shaft. The compact Cone Clamping Element is a cost-efficient solution especially for applications with low space requirements.

Transmissible torques and axial forces

The transmissible torques or axial forces listed on the following page are subject to the following tolerances, surface characteristics and material requirements. Please contact us in the case of deviations.

Tolerances

- h8 for shaft diameter d
- H8 for hub bore D

Surfaces

Average surface roughness at the contact surfaces between the shaft and the hub bore:
 $R_z = 10 \dots 25 \mu\text{m}$.

Materials

The following apply to the shaft and the hub:

- E-module $\geq 170 \text{ kN/mm}^2$

Installation

Please request our installation and operating instructions for Cone Clamping Elements RLK 132.

Simultaneous transmission of torque and axial force

The transmissible torques M which are shown in the tables apply for axial forces $F = 0 \text{ kN}$ and conversely, the indicated axial forces F apply to torques $M = 0 \text{ Nm}$. If torque and axial force are to be transmitted simultaneously, the transmissible torque and the transmissible axial force are reduced. Please refer to the technical points on pages 74 and 75.

Example for ordering

Cone Clamping Element RLK 132 for shaft diameter $d = 100 \text{ mm}$:

- RLK 132, size 100 x 145
Article number 4204-100201-000000

centres the hub to the shaft
short axial width

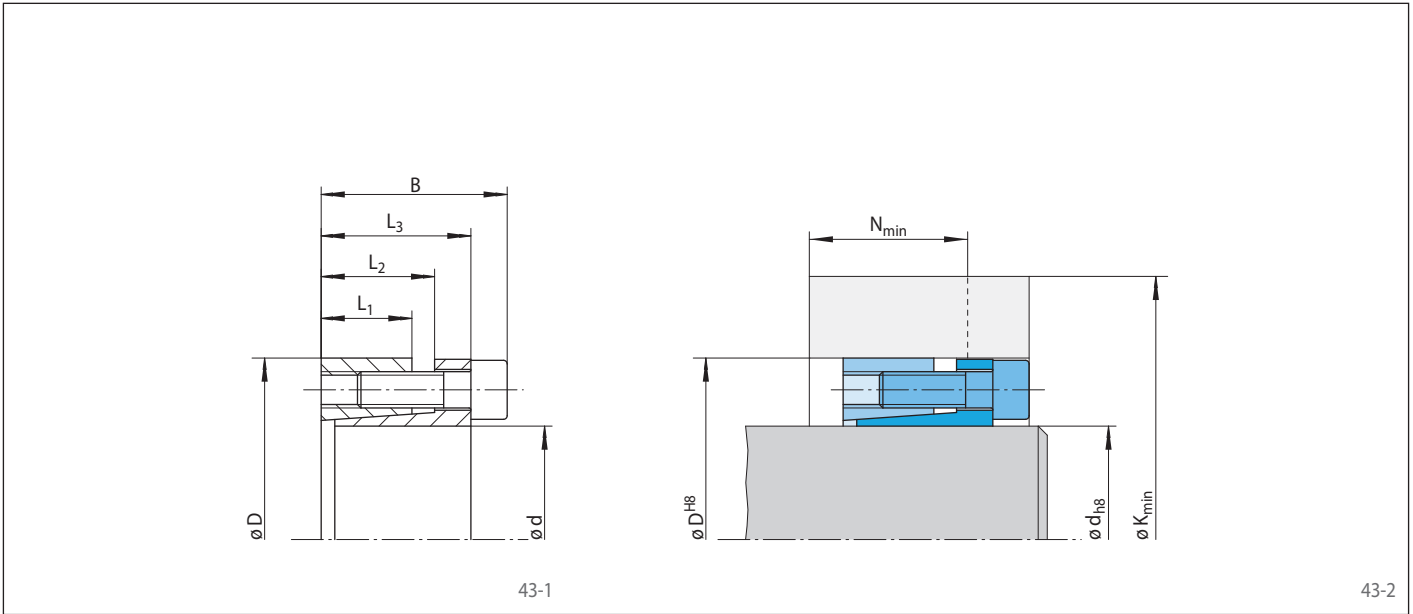

Dimensions													Technical Data							Article number	
Size		Yield strength R_e of the hub material [N/mm ²]					Transmissible torque or axial force		Contact pressure at		Clamping screws			Weight							
d mm	D mm	B mm	L ₁ mm	L ₂ mm	L ₃ mm	K_{min} mm	N_{min} mm	K_{min} mm	N_{min} mm	K_{min} mm	N_{min} mm	M Nm	F kN		Shaft P_W N/mm ²	Hub P_N N/mm ²	Tightening torque M_5 Nm	Number	Size		Length mm
20	47	34	17	22	28	104	46	81	34	69	28	580	58	450	192	17,4	6	M 6	20	0,3	4204-020201-000000
22	47	34	17	22	28	104	46	81	34	69	28	630	58	409	192	17,4	6	M 6	20	0,3	4204-022201-000000
24	50	34	17	22	28	104	44	83	34	71	28	690	58	375	180	17,4	6	M 6	20	0,3	4204-024201-000000
25	50	34	17	22	28	104	44	83	34	71	28	720	58	360	180	17,4	6	M 6	20	0,3	4204-025201-000000
28	55	34	17	22	28	106	43	87	33	76	28	810	58	322	164	17,4	6	M 6	20	0,3	4204-028201-000000
30	55	34	17	22	28	106	43	87	33	76	28	860	58	300	164	17,4	6	M 6	20	0,3	4204-030201-000000
32	60	34	17	22	28	124	49	100	37	86	30	1250	77	375	200	17,4	8	M 6	20	0,4	4204-032201-000000
35	60	34	17	22	28	124	49	100	37	86	30	1350	77	343	200	17,4	8	M 6	20	0,3	4204-035201-000000
38	65	34	17	22	28	126	48	104	37	91	30	1450	77	316	185	17,4	8	M 6	20	0,4	4204-038201-000000
40	65	34	17	22	28	126	48	104	37	91	30	1550	77	300	185	17,4	8	M 6	20	0,4	4204-040201-000000
42	75	41	20	25	33	152	59	124	45	107	36	2350	110	358	200	34,0	8	M 8	25	0,6	4204-042201-000000
45	75	41	20	25	33	152	59	124	45	107	36	2500	110	334	200	34,0	8	M 8	25	0,6	4204-045201-000000
48	80	41	20	24	33	158	59	130	45	113	37	2900	120	334	200	36,0	8	M 8	25	0,7	4204-048201-000000
50	80	41	20	24	33	158	59	130	45	113	37	3000	120	320	200	36,0	8	M 8	25	0,7	4204-050201-000000
55	85	41	20	24	33	167	61	137	46	120	38	3600	130	310	200	39,0	8	M 8	25	0,7	4204-055201-000000
60	90	41	20	24	33	173	62	144	47	126	38	4100	140	300	200	41,0	8	M 8	25	0,8	4204-060201-000000
65	95	41	20	24	33	177	61	149	47	131	38	4600	140	287	196	42,2	8	M 8	25	0,8	4204-065201-000000
70	110	50	24	29	40	210	74	175	57	154	46	7000	200	315	200	75,0	8	M 10	30	1,5	4204-070201-000000
75	115	50	24	29	40	216	75	181	57	160	47	7800	210	307	200	78,0	8	M 10	30	1,6	4204-075201-000000
80	120	50	24	29	40	224	76	188	58	166	47	8700	220	300	200	82,0	8	M 10	30	1,7	4204-080201-000000
85	125	50	24	29	40	230	77	194	59	172	48	9600	230	295	200	68,0	10	M 10	30	1,8	4204-085201-000000
90	130	50	24	29	40	237	78	201	60	178	48	10600	240	289	200	71,0	10	M 10	30	1,9	4204-090201-000000
95	135	50	24	29	40	242	78	206	60	184	49	11500	240	285	200	73,0	10	M 10	30	2,0	4204-095201-000000
100	145	56	26	31	44	261	84	222	65	197	52	14000	280	290	200	126,0	8	M 12	30	2,6	4204-100201-000000
110	155	56	26	31	44	274	86	234	66	209	53	16500	300	282	200	135,0	8	M 12	30	2,8	4204-110201-000000
120	165	56	26	31	44	286	87	246	67	221	54	19500	320	275	200	127,0	9	M 12	30	3,6	4204-120201-000000
130	180	64	34	39	52	328	108	277	83	246	67	30000	460	277	200	136,0	12	M 12	30	4,4	4204-130201-000000
140	190	68	34	39	54	341	110	290	84	258	68	34000	490	272	200	223,0	9	M 14	40	4,9	4204-140201-000000
150	200	68	34	39	54	354	111	303	86	270	69	38500	510	267	200	211,0	10	M 14	40	5,2	4204-150201-000000
160	210	68	34	39	54	367	113	315	87	283	71	43000	540	263	200	185,0	12	M 14	40	5,6	4204-160201-000000
170	225	78	44	49	64	396	130	337	100	301	82	56500	670	237	179	229,0	12	M 14	40	6,9	4204-170201-000000
180	235	78	44	49	64	402	128	346	100	310	82	60000	670	224	172	229,0	12	M 14	40	8,5	4204-180201-000000
190	250	78	44	49	64	447	143	381	110	339	89	79000	830	264	200	228,0	15	M 14	40	9,0	4204-190201-000000
200	260	78	44	49	64	454	141	389	109	349	89	83500	830	252	194	229,0	15	M 14	40	9,6	4204-200201-000000

Cone Clamping Elements RLK 133

centres the hub to the shaft
short axial width with fixed backstop point



Features

- Centres the shaft to the hub
- Short axial width
- No axial displacement between hub and shaft during clamping procedure due to fixed backstop point
- Transmissible torque of 350 Nm up to 51 500 Nm
- For shaft diameters between 20 mm and 200 mm

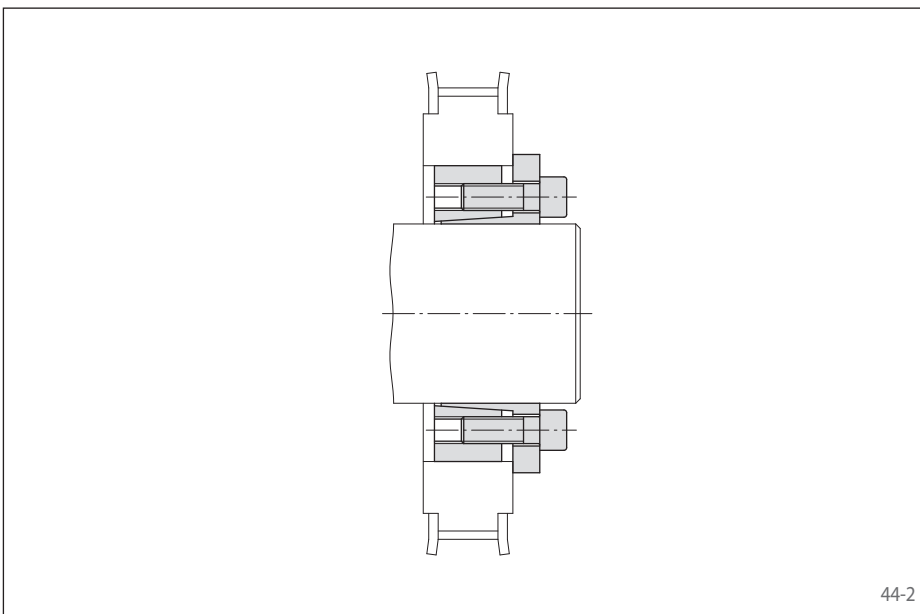

Application example

Backlash free connection of a timing belt pulley to the drive shaft with a Cone Clamping Element RLK 133. Due to the fixed backstop point, the timing belt pulley is not displaced axially during clamping. The Cone Clamping Element also centres the timing belt pulley to the shaft. The compact Cone Clamping Element is a cost-efficient solution especially for applications with low space requirements.

Transmissible torques and axial forces

The transmissible torques or axial forces listed on the following page are subject to the following tolerances, surface characteristics and material requirements. Please contact us in the case of deviations.

Tolerances

- h8 for shaft diameter d
- H8 for hub bore D

Surfaces

Average surface roughness at the contact surfaces between the shaft and the hub bore:
 $R_z = 10 \dots 25 \mu\text{m}$.

Materials

The following apply to the shaft and the hub:

- E-module $\geq 170 \text{ kN/mm}^2$

Installation

Please request our installation and operating instructions for Cone Clamping Elements RLK 133.

Simultaneous transmission of torque and axial force

The transmissible torques M which are shown in the tables apply for axial forces $F = 0 \text{ kN}$ and conversely, the indicated axial forces F apply to torques $M = 0 \text{ Nm}$. If torque and axial force are to be transmitted simultaneously, the transmissible torque and the transmissible axial force are reduced. Please refer to the technical points on pages 74 and 75.

Example for ordering

Cone Clamping Element RLK 133 for shaft diameter $d = 100 \text{ mm}$:

- RLK 133, size 100 x 145
Article number 4204-100301-000000

Cone Clamping Elements RLK 133

centres the hub to the shaft
short axial width with fixed backstop point

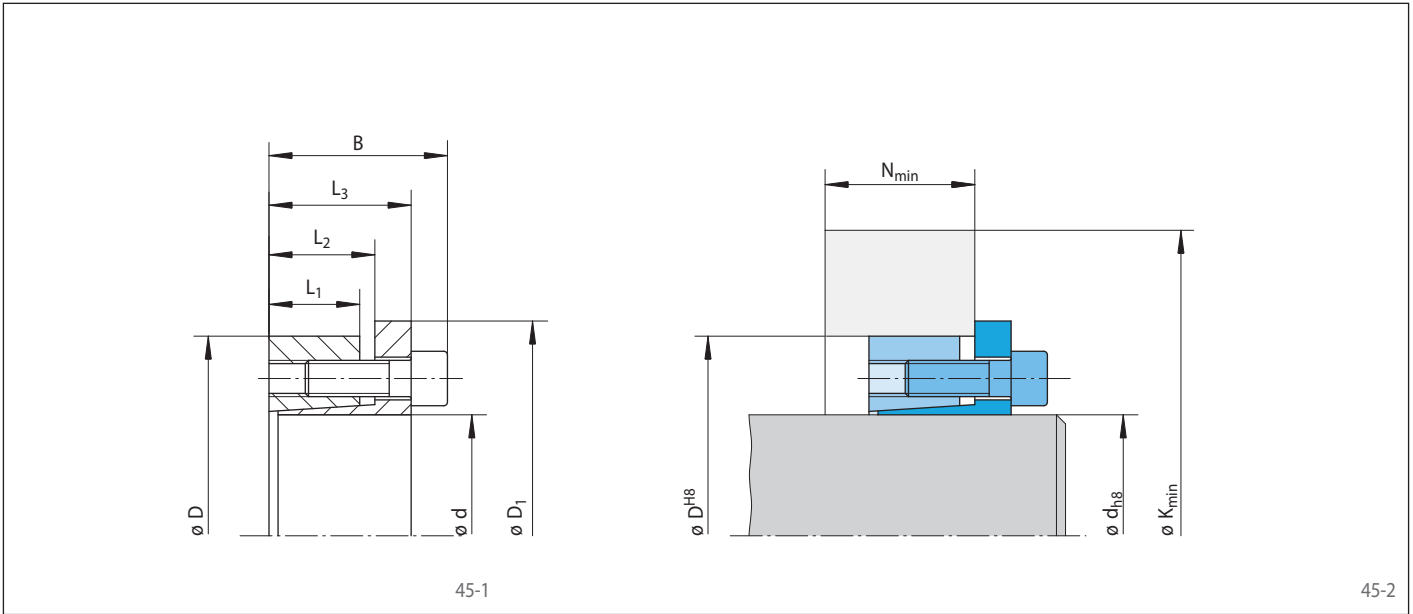

Dimensions													Technical Data										Article number
Size		D ₁ mm	B mm	L ₁ mm	L ₂ mm	L ₃ mm	Yield strength R _e of the hub material [N/mm ²]						Transmissible torque or axial force		Contact pressure at		Clamping screws			Weight kg			
d mm	D mm						200	320	500	M	F	Shaft P _W N/mm ²	Hub P _N N/mm ²	Tightening torque M ₅ Nm	Number	Size	Length mm						
20	47	53	34	17	22	28	96	30	74	24	63	21	350	35	277	118	17,4	6	M 6	20	0,3	4204-020301-000000	
22	47	53	34	17	22	28	96	30	74	24	63	21	390	35	252	118	17,4	6	M 6	20	0,3	4204-022301-000000	
24	50	56	34	17	22	28	96	29	76	24	66	21	430	35	231	111	17,4	6	M 6	20	0,3	4204-024301-000000	
25	50	56	34	17	22	28	96	29	76	24	66	21	440	35	222	111	17,4	6	M 6	20	0,3	4204-025301-000000	
28	55	62	34	17	22	28	98	28	80	24	70	21	500	35	198	101	17,4	6	M 6	20	0,4	4204-028301-000000	
30	55	62	34	17	22	28	98	28	80	24	70	21	530	35	185	101	17,4	6	M 6	20	0,4	4204-030301-000000	
32	60	69	34	17	22	28	117	32	93	26	80	22	760	47	231	123	17,4	8	M 6	20	0,4	4204-032301-000000	
35	60	69	34	17	22	28	117	32	93	26	80	22	830	47	211	123	17,4	8	M 6	20	0,4	4204-035301-000000	
38	65	72	34	17	22	28	119	31	97	25	85	22	900	47	194	114	17,4	8	M 6	20	0,5	4204-038301-000000	
40	65	72	34	17	22	28	119	31	97	25	85	22	940	47	185	114	17,4	8	M 6	20	0,4	4204-040301-000000	
42	75	84	41	20	25	33	165	43	127	33	106	28	1800	86	273	153	42,2	8	M 8	25	0,8	4204-042301-000000	
45	75	84	41	20	25	33	165	43	127	33	106	28	1950	86	255	153	42,2	8	M 8	25	0,7	4204-045301-000000	
48	80	89	41	20	24	33	165	42	130	33	111	28	2050	86	239	143	42,2	8	M 8	25	0,8	4204-048301-000000	
50	80	89	41	20	24	33	165	42	130	33	111	28	2150	86	229	143	42,2	8	M 8	25	0,8	4204-050301-000000	
55	85	91	41	20	24	33	166	41	133	32	115	28	2350	86	208	135	42,2	8	M 8	25	0,8	4204-055301-000000	
60	90	99	41	20	24	33	168	40	137	32	120	28	2600	86	191	128	42,2	8	M 8	25	0,9	4204-060301-000000	
65	95	104	41	20	24	33	171	39	141	32	124	28	2800	86	176	121	42,2	8	M 8	25	0,9	4204-065301-000000	
70	110	119	50	24	29	40	213	50	172	40	149	34	4800	140	215	137	83,0	8	M 10	30	1,7	4204-070301-000000	
75	115	124	50	24	29	40	215	49	176	40	153	34	5100	140	201	131	83,0	8	M 10	30	1,8	4204-075301-000000	
80	120	129	50	24	29	40	218	49	179	39	158	34	5400	140	188	126	83,0	8	M 10	30	1,9	4204-080301-000000	
85	125	134	50	24	29	40	246	55	198	43	172	36	7200	170	221	151	83,0	10	M 10	30	2,0	4204-085301-000000	
90	130	139	50	24	29	40	248	54	202	42	176	36	7600	170	209	145	83,0	10	M 10	30	2,1	4204-090301-000000	
95	135	144	50	24	29	40	250	53	206	42	180	36	8100	170	198	140	83,0	10	M 10	30	2,2	4204-095301-000000	
100	145	154	56	26	31	44	269	57	221	45	194	39	10000	200	204	141	144,0	8	M 12	30	2,8	4204-100301-000000	
110	155	164	56	26	31	44	274	56	229	45	203	38	11000	200	186	132	144,0	8	M 12	30	3,0	4204-110301-000000	
120	165	174	56	26	31	44	295	59	246	47	218	40	13500	220	191	139	144,0	9	M 12	30	3,4	4204-120301-000000	
130	180	189	64	34	39	52	326	71	269	57	237	49	19500	300	180	130	144,0	12	M 12	30	5,1	4204-130301-000000	
140	190	199	68	34	39	54	336	71	280	57	248	49	21500	310	172	127	229,0	9	M 14	40	5,3	4204-140301-000000	
150	200	209	68	34	39	54	358	74	298	59	263	50	25500	340	178	134	229,0	10	M 14	40	5,6	4204-150301-000000	
160	210	219	68	34	39	54	395	81	325	63	284	53	33000	410	200	153	229,0	12	M 14	40	6,0	4204-160301-000000	
170	225	234	78	44	49	64	381	83	321	68	286	60	35000	410	146	110	229,0	12	M 14	40	8,2	4204-170301-000000	
180	235	244	78	44	49	64	387	82	329	68	295	59	37000	410	138	106	229,0	12	M 14	40	8,6	4204-180301-000000	
190	250	259	78	44	49	64	435	91	365	73	324	63	48500	510	163	124	229,0	15	M 14	40	10,0	4204-190301-000000	
200	260	269	78	44	49	64	441	90	373	73	333	63	51500	510	155	119	229,0	15	M 14	40	10,4	4204-200301-000000	

Cone Clamping Elements RLK 133 TC

Premium quality for high centering accuracy
Can be assembled multiple times



46-1

Features

- Centres the shaft to the hub. Double slot for high centering accuracy.
- Can be assembled multiple times
- Highest transmissible torque
- Short axial width
- No axial displacement between hub and shaft during clamping procedure due to fixed backstop point
- Highest machining quality
- Transmissible torque of 4800 Nm up to 567 500 Nm
- For shaft diameters between 70 mm and 520 mm

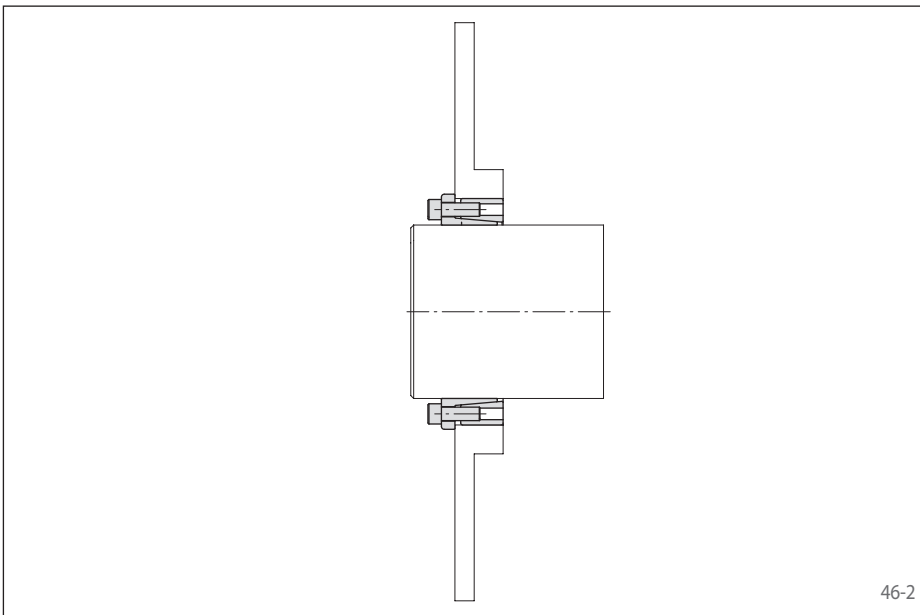

46-2

Application example

Backlash free connection of a brake disc to the drive shaft with a Cone Clamping Element RLK 133 TC. Due to the fixed backstop point, the brake disc is not displaced axially during clamping. The Cone Clamping Element also centres the brake disc to the shaft. The compact Cone Clamping Element is a cost-efficient solution especially for applications with low space requirements.

Transmissible torques and axial forces

The transmissible torques or axial forces listed on the following page are subject to the following tolerances, surface characteristics and material requirements. Please contact us in the case of deviations.

Tolerances

- h8 for shaft diameter d
- H8 for hub bore D

Surfaces

Average surface roughness at the contact surfaces between the shaft and the hub bore:
 $R_z = 10 \dots 25 \mu\text{m}$.

Materials

The following apply to the shaft and the hub:

- E-module $\geq 170 \text{ kN/mm}^2$

Installation

Please request our installation and operating instructions for Cone Clamping Elements RLK 133 TC.

Simultaneous transmission of torque and axial force

The transmissible torques M which are shown in the tables apply for axial forces $F = 0 \text{ kN}$ and conversely, the indicated axial forces F apply to torques $M = 0 \text{ Nm}$. If torque and axial force are to be transmitted simultaneously, the transmissible torque and the transmissible axial force are reduced. Please refer to the technical points on pages 74 and 75.

Example for ordering

Cone Clamping Element RLK 133 TC for shaft diameter $d = 100 \text{ mm}$:

- RLK 133 TC, size 100 x 145
Article number 4204-100301-TC0000

Premium quality for high centering accuracy
Can be assembled multiple times

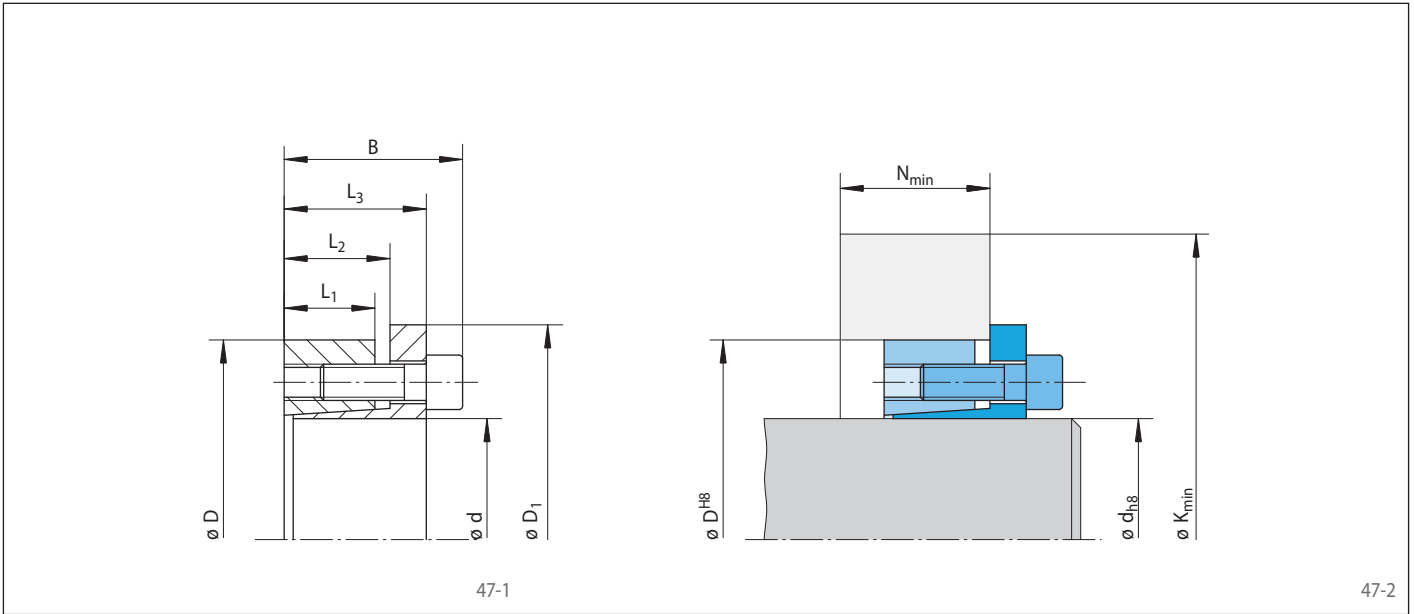

Dimensions										Technical Data										Article number		
Size		Yield strength R_e of the hub material [N/mm ²]						Transmissible torque or axial force		Contact pressure at Shaft		Clamping screws			Weight							
d	D	200		320		500		M	F	P_W	P_N	Tightening torque M_5	Number	Size		Length	kg					
mm	mm	D_1	B	L_1	L_2	L_3	K_{min}	N_{min}	K_{min}	N_{min}	K_{min}	N_{min}	N/mm ²	N/mm ²	Nm		mm					
70	110	119	50	24	30	40	213	50	172	40	149	34	4800	140	215	137	83	8	M 10	30	1,7	4204-070301-TC0000
75	115	124	50	24	30	40	215	49	176	40	153	34	5100	140	201	131	83	8	M 10	30	1,8	4204-075301-TC0000
80	120	129	50	24	30	40	218	49	179	39	158	34	5400	140	188	126	83	8	M 10	30	1,9	4204-080301-TC0000
85	125	134	50	24	30	40	233	51	191	41	167	35	6500	150	199	136	83	9	M 10	30	2,0	4204-085301-TC0000
90	130	139	50	24	30	40	235	51	195	41	171	35	6900	150	188	130	83	9	M 10	30	2,1	4204-090301-TC0000
95	135	144	50	24	30	40	250	53	206	42	180	36	8100	170	198	140	83	10	M 10	30	2,2	4204-095301-TC0000
100	145	154	56	26	32	44	269	57	221	45	194	39	10000	200	204	141	144	8	M 12	30	2,8	4204-100301-TC0000
110	155	164	56	26	32	44	274	56	229	45	203	38	11000	200	186	132	144	8	M 12	30	3,0	4204-110301-TC0000
120	165	174	56	26	32	44	295	59	246	47	218	40	13500	220	191	139	144	9	M 12	30	3,4	4204-120301-TC0000
130	180	189	64	34	40	52	326	71	269	57	237	49	19500	300	180	130	144	12	M 12	30	5,1	4204-130301-TC0000
140	190	199	68	34	40	54	336	71	280	57	248	49	21500	310	172	127	229	9	M 14	40	5,3	4204-140301-TC0000
150	200	209	68	34	40	54	358	74	298	59	263	50	25500	340	178	134	229	10	M 14	40	5,6	4204-150301-TC0000
160	210	219	68	34	40	54	379	77	315	61	278	51	30000	380	184	140	229	11	M 14	40	6,0	4204-160301-TC0000
170	225	234	78	44	50	64	381	83	321	68	286	60	35000	410	146	110	229	12	M 14	40	8,2	4204-170301-TC0000
180	235	244	78	44	50	64	387	82	329	68	295	59	37000	410	138	106	229	12	M 14	40	8,6	4204-180301-TC0000
190	250	259	78	44	50	64	435	91	365	73	324	63	48500	510	163	124	229	15	M 14	40	10,0	4204-190301-TC0000
200	260	269	78	44	50	64	441	90	373	73	333	63	51500	510	155	119	229	15	M 14	40	10,4	4204-200301-TC0000
220	285	294	88	50	56	72	463	95	396	78	356	68	61500	560	136	105	354	12	M 16	40	13,9	4204-220301-TC0000
240	305	314	88	50	56	72	520	104	440	84	392	72	84000	700	155	122	354	15	M 16	40	14,8	4204-240301-TC0000
260	325	334	88	50	56	72	575	113	482	90	427	76	109500	840	172	138	354	18	M 16	40	16,1	4204-260301-TC0000
280	355	364	102	60	66	84	592	120	503	97	451	84	127500	910	144	114	492	16	M 18	50	23,6	4204-280301-TC0000
300	375	384	102	60	66	84	635	125	538	101	481	87	154000	1050	152	121	492	18	M 18	50	25,7	4204-300301-TC0000
320	405	414	121	74	81	101	692	146	582	119	519	103	210500	1300	148	117	692	18	M 20	50	36,1	4204-320301-TC0000
340	425	434	121	74	81	101	753	156	628	125	556	107	261000	1550	162	130	692	21	M 20	50	38,3	4204-340301-TC0000
360	455	464	138	86	94	116	769	165	648	135	578	117	294500	1650	141	111	945	18	M 22	60	52,5	4204-360301-TC0000
380	475	484	138	86	94	116	835	176	697	142	617	122	363000	1900	155	124	945	21	M 22	60	55,0	4204-380301-TC0000
400	495	504	138	86	94	116	846	174	713	141	636	122	382000	1900	148	119	945	21	M 22	60	60,3	4204-400301-TC0000
420	515	524	138	86	94	116	876	176	740	143	661	123	420000	2000	147	120	945	22	M 22	60	62,9	4204-420301-TC0000
440	535	544	138	86	94	116	888	174	757	142	679	122	440000	2000	141	116	945	22	M 22	60	65,6	4204-440301-TC0000
460	555	564	138	86	94	116	902	173	774	141	698	122	460000	2000	135	112	945	22	M 22	60	68,3	4204-460301-TC0000
480	575	584	138	86	94	116	947	179	810	145	729	125	523500	2200	141	118	945	24	M 22	60	71,0	4204-480301-TC0000
500	595	604	138	86	94	116	960	177	828	145	748	125	545500	2200	135	114	945	24	M 22	60	73,7	4204-500301-TC0000
520	615	624	138	86	94	116	975	176	845	144	766	124	567500	2200	130	110	945	24	M 22	60	75,9	4204-520301-TC0000

Cone Clamping Elements RLK 136 TC

Premium quality for high centering accuracy
Can be assembled multiple times



Features

- Centres the shaft to the hub. Double slot for high centering accuracy.
- Can be assembled multiple times
- Highest transmissible torque
- Short axial width
- No axial displacement between hub and shaft during clamping procedure due to fixed backstop point
- Highest machining quality
- Transmissible torque of 6 700 Nm up to 994 500 Nm
- For shaft diameters between 70 mm and 600 mm

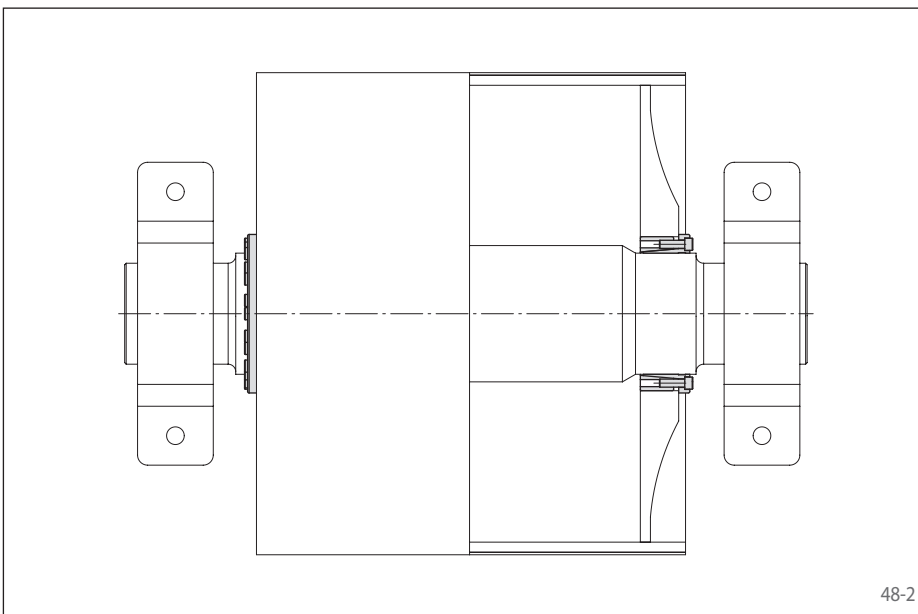

Application example

Backlash free attachment of a belt drum to the drive shaft of a conveyor belt with an Cone Clamping Element RLK 136 TC. The Cone Clamping Element centres the belt drum on the drive shaft. As no axial shift occurs during the clamping process, the axial position of the belt drum in relation to the drive shaft remains unchanged.

Transmissible torques and axial forces

The transmissible torques or axial forces listed on the following page are subject to the following tolerances, surface characteristics and material requirements. Please contact us in the case of deviations.

Tolerances

- h8 for shaft diameter d
- H8 for hub bore D

Surfaces

Average surface roughness at the contact surfaces between the shaft and the hub bore:
 $R_z = 10 \dots 25 \mu\text{m}$.

Materials

The following apply to the shaft and the hub:

- E-module $\geq 170 \text{ kN/mm}^2$

Installation

Please request our installation and operating instructions for Cone Clamping Elements RLK 136 TC.

Simultaneous transmission of torque and axial force

The transmissible torques M which are shown in the tables apply for axial forces $F = 0 \text{ kN}$ and conversely, the indicated axial forces F apply to torques $M = 0 \text{ Nm}$. If torque and axial force are to be transmitted simultaneously, the transmissible torque and the transmissible axial force are reduced. Please refer to the technical points on pages 74 and 75.

Example for ordering

Cone Clamping Element RLK 136 TC for shaft diameter $d = 100 \text{ mm}$:

- RLK 136 TC, size 100 x 150
Article number 4204-100601-TC0000

Cone Clamping Elements RLK 136 TC

Premium quality for high centering accuracy
Can be assembled multiple times

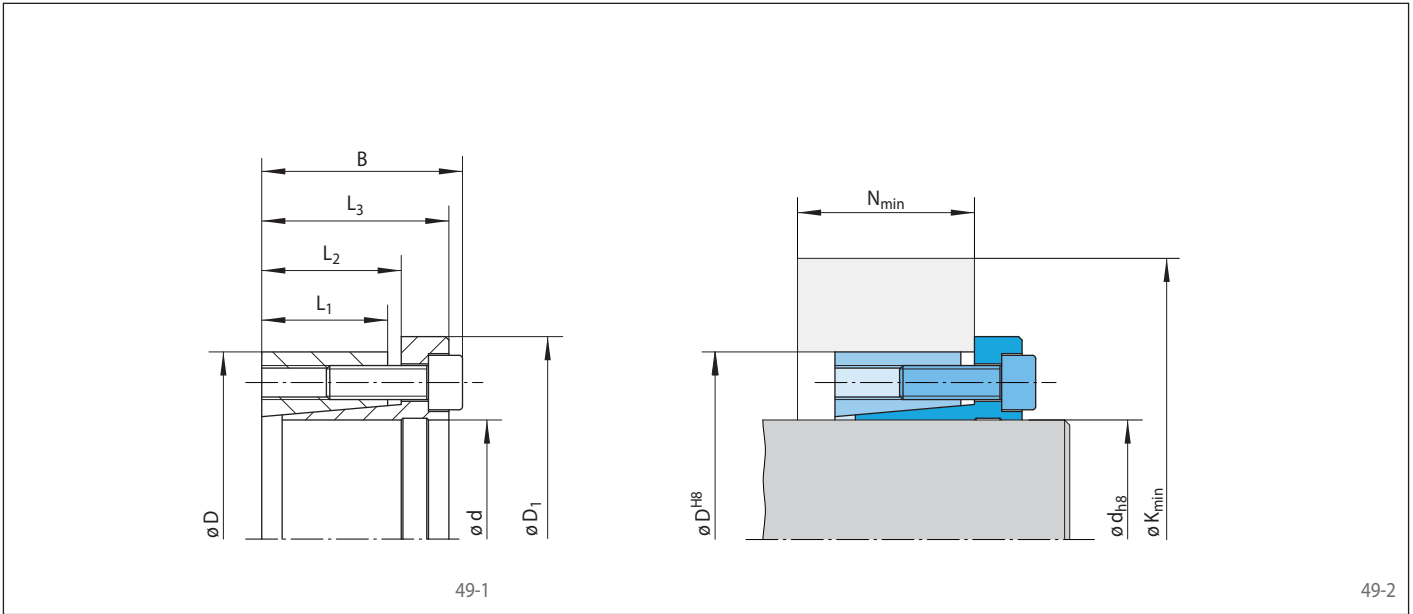

Dimensions										Technical Data										Article number		
Size		Yield strength R_e of the hub material [N/mm ²]						Transmissible torque or axial force		Contact pressure at		Clamping screws				Weight						
d	D	200		320		500		M	F	Shaft	Hub	Tightening torque	Number	Size	Length		kg					
mm	mm	D_1	B	L_1	L_2	L_3	K_{min}	N_{min}	K_{min}	N_{min}	K_{min}	N_{min}	N/mm ²	N/mm ²	M_5		mm					
70	110	119	61	37	43	57	230	67	177	54	150	47	6700	190	198	126	83	12	M 10	30	2,5	4204-070601-TC0000
75	115	124	61	37	43	57	231	66	180	54	154	47	7200	190	185	121	83	12	M 10	30	2,6	4204-075601-TC0000
80	120	129	61	37	43	57	255	71	196	56	166	49	9000	220	202	135	83	14	M 10	30	2,8	4204-080601-TC0000
90	130	139	61	37	43	57	257	69	203	56	174	48	10100	220	179	124	83	14	M 10	30	3,0	4204-090601-TC0000
100	150	159	68,5	40	46	64	320	83	248	65	209	55	16500	330	219	146	144	14	M 12	40	4,7	4204-100601-TC0000
110	160	169	68,5	40	46	64	321	81	254	64	218	55	18000	330	200	137	144	14	M 12	40	5,1	4204-110601-TC0000
120	170	179	68,5	40	46	64	350	85	276	67	235	57	22500	380	209	148	144	16	M 12	40	5,4	4204-120601-TC0000
130	185	194	81,5	48	55	75	405	103	312	80	262	68	33500	520	220	155	229	16	M 14	40	7,5	4204-130601-TC0000
140	195	204	81,5	48	55	75	406	101	318	79	271	67	36000	520	204	147	229	16	M 14	40	8,8	4204-140601-TC0000
150	205	214	81,5	48	55	75	438	107	342	83	289	69	43500	580	215	157	229	18	M 14	40	8,6	4204-150601-TC0000
160	215	224	81,5	48	55	75	439	104	348	82	298	69	46500	580	201	150	229	18	M 14	40	8,9	4204-160601-TC0000
170	230	239	99	64	71	93	492	130	380	102	320	87	67500	800	194	144	354	18	M 16	50	12,7	4204-170601-TC0000
180	240	249	99	64	71	93	493	128	386	101	329	87	71500	800	184	138	354	18	M 16	50	13,3	4204-180601-TC0000
190	250	259	99	64	71	93	528	134	411	105	348	89	84000	880	193	147	354	20	M 16	50	13,9	4204-190601-TC0000
200	260	269	99	64	71	93	529	132	417	104	357	89	88500	880	184	141	354	20	M 16	50	14,6	4204-200601-TC0000
220	285	294	102	66	74	96	532	128	432	103	377	89	97000	880	162	125	354	20	M 16	50	17,8	4204-220601-TC0000
240	305	314	102	66	74	96	595	139	478	110	413	93	127000	1050	178	140	354	24	M 16	50	19,2	4204-240601-TC0000
260	325	334	102	66	74	96	628	142	508	112	440	95	149500	1150	178	143	354	26	M 16	50	19,5	4204-260601-TC0000
280	355	364	120	77	87	112	656	153	535	122	468	106	181000	1300	159	126	492	24	M 18	60	19,7	4204-280601-TC0000
300	375	384	120	77	87	112	692	157	566	125	496	108	210000	1400	161	129	492	26	M 18	60	30,6	4204-300601-TC0000
320	405	414	130	84	94	122	749	170	613	136	536	117	265500	1650	164	130	692	24	M 20	60	42,7	4204-320601-TC0000
340	425	434	130	84	94	122	819	183	664	144	576	122	329000	1950	180	144	692	28	M 20	60	44,9	4204-340601-TC0000
360	445	454	141	91	101	133	841	190	684	151	595	129	373000	2050	168	136	692	30	M 20	60	52,4	4204-360601-TC0000
380	465	474	141	91	101	133	877	194	715	154	623	131	420000	2200	170	139	692	32	M 20	60	54,0	4204-380601-TC0000
400	485	494	141	90	101	133	915	198	748	156	652	132	469500	2350	174	143	692	34	M 20	60	56,2	4204-400601-TC0000
420	505	514	141	90	101	133	924	195	763	155	670	132	493000	2350	165	138	692	34	M 20	60	59,2	4204-420601-TC0000
440	525	534	155	103	115	147	931	205	773	165	682	143	547000	2500	146	122	692	36	M 20	60	70,6	4204-440601-TC0000
460	545	554	155	103	115	147	966	208	803	168	709	144	603500	2600	147	125	692	38	M 20	60	71,2	4204-460601-TC0000
480	565	574	155	103	115	147	977	206	819	167	728	144	630000	2600	141	120	692	38	M 20	60	75,1	4204-480601-TC0000
500	585	594	160	107	120	152	1003	212	843	172	750	149	691000	2800	137	118	692	40	M 20	60	79,9	4204-500601-TC0000
520	605	614	160	107	120	152	1015	210	859	171	769	148	718500	2800	132	114	692	40	M 20	60	80,5	4204-520601-TC0000
540	625	634	160	107	120	152	1049	213	889	173	795	150	783500	2900	134	116	692	42	M 20	60	82,8	4204-540601-TC0000
560	645	654	160	107	120	152	1082	216	918	176	822	152	851000	3000	135	117	692	44	M 20	60	85,7	4204-560601-TC0000
580	665	674	160	107	120	152	1115	220	947	178	848	153	921500	3200	136	119	692	46	M 20	60	89,0	4204-580601-TC0000
600	685	694	160	107	120	152	1147	223	976	180	874	155	994500	3300	137	120	692	48	M 20	60	91,3	4204-600601-TC0000

easy to release
compact design

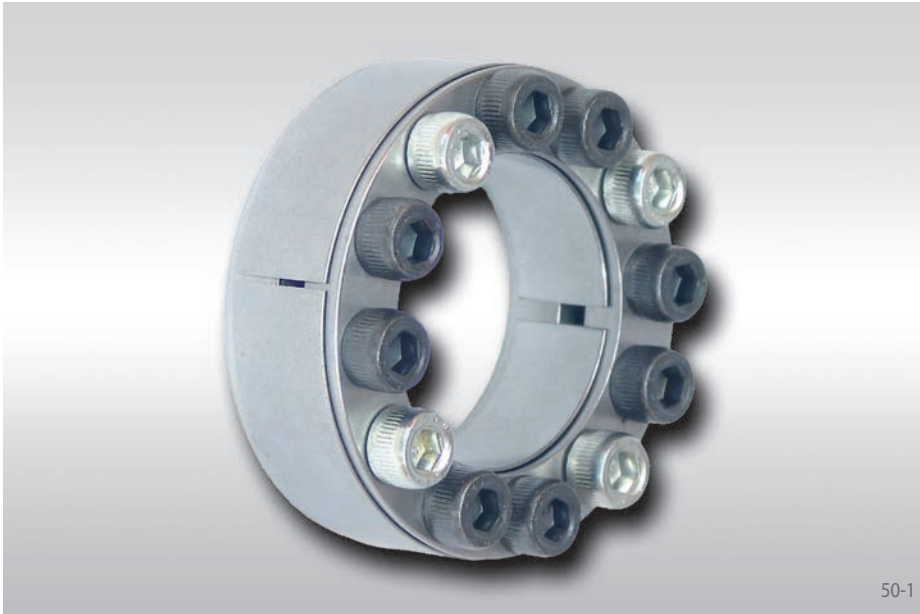

50-1

Features

- Easy to release
- Compact design
- No axial displacement between hub and shaft during clamping procedure
- Extended tolerances for hub and shaft
- Transmissible torque of 300 Nm up to 428 500 Nm
- For shaft diameters between 20 mm and 400 mm

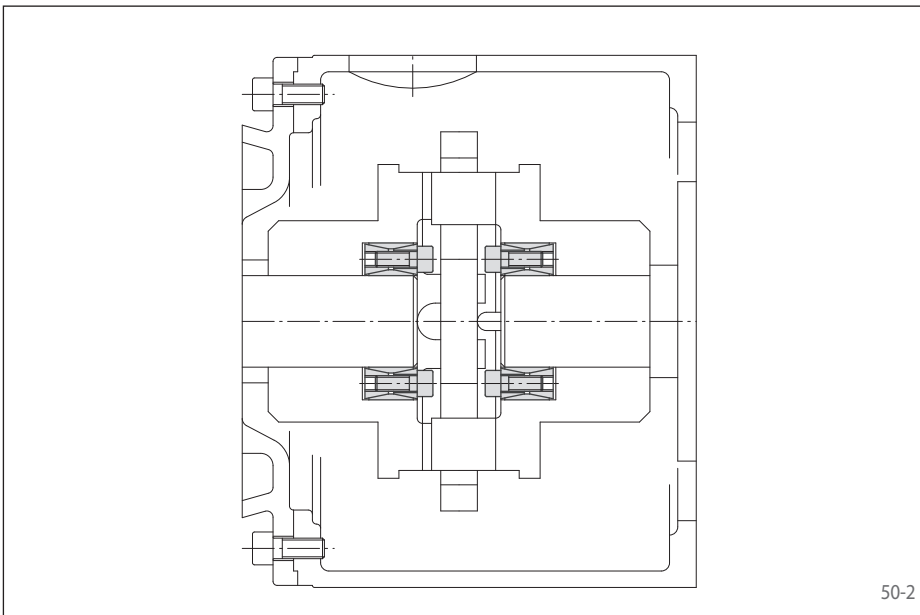

50-2

Application example

Backlash free connection of the two hubs of a Flexible Coupling L42 from RINGSPANN with a Cone Clamping Element RLK 200. The Flexible Coupling is situated in the lantern of a geared motor driving a roller conveyor.

Transmissible torques and axial forces

The transmissible torques or axial forces listed on the following page are subject to the following tolerances, surface characteristics and material requirements. Please contact us in the case of deviations.

Tolerances

- h9 for shaft diameter d
- H9 for hub bore D

Surfaces

Average surface roughness at the contact surfaces between the shaft and the hub bore:
 $R_z = 10 \dots 25 \mu\text{m}$.

Materials

The following apply to the shaft and the hub:

- E-module $\geq 170 \text{ kN/mm}^2$

Installation

Please request our installation and operating instructions for Cone Clamping Elements RLK 200.

Simultaneous transmission of torque and axial force

The transmissible torques M which are shown in the tables apply for axial forces $F = 0 \text{ kN}$ and conversely, the indicated axial forces F apply to torques $M = 0 \text{ Nm}$. If torque and axial force are to be transmitted simultaneously, the transmissible torque and the transmissible axial force are reduced. Please refer to the technical points on pages 74 and 75.

Example for ordering

Cone Clamping Element RLK 200 for shaft diameter $d = 100 \text{ mm}$:

- RLK 200, size 100 x 145
Article number 4201-100001-000000

easy to release
compact design

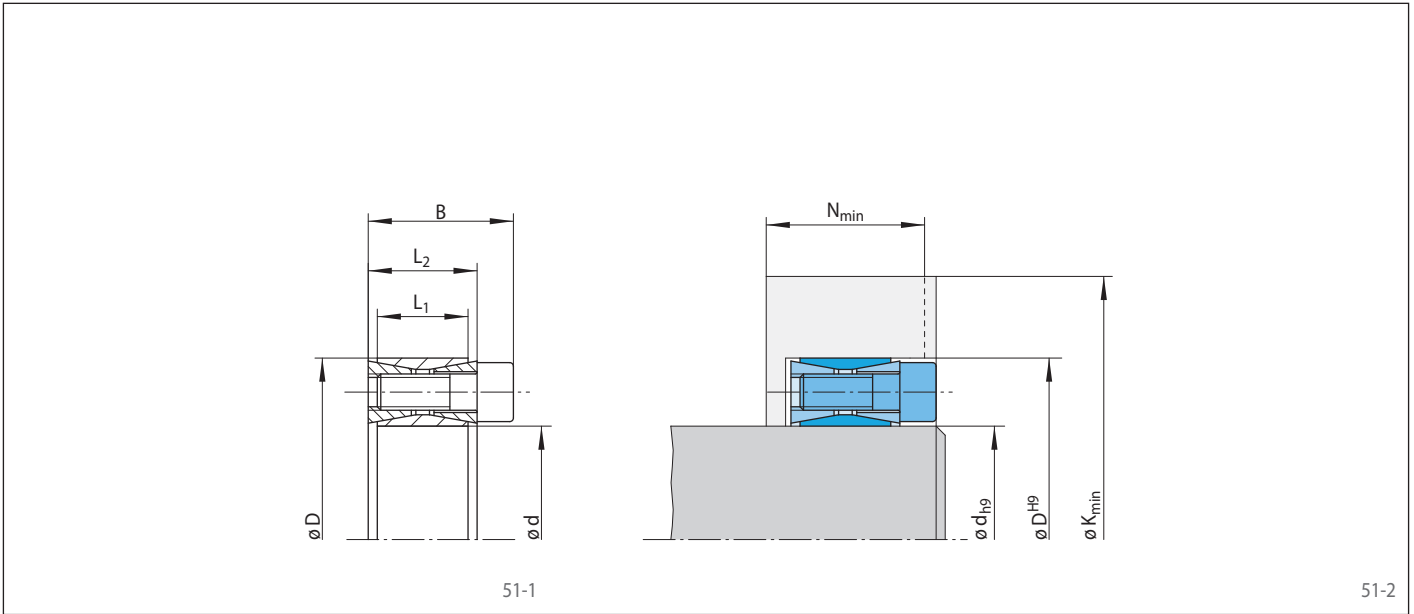

Dimensions												Technical Data								Article number
Size		Yield strength R_e of the hub material [N/mm ²]										Transmissible torque or axial force		Contact pressure at		Clamping screws			Weight	
d mm	D mm	B mm	L ₁ mm	L ₂ mm	200		320		500		M Nm	F kN	Shaft P _w N/mm ²	Hub P _N N/mm ²	Tightening torque M _s Nm	Number	Size	Length mm		
20	47	26	17	20	76	32	65	26	59	23	300	30	236	101	17,4	8	M 6	18	0,2	4201-020001-000000
22	47	26	17	20	76	32	65	26	59	23	330	30	214	101	17,4	8	M 6	18	0,2	4201-022001-000000
24	50	26	17	20	78	31	68	26	62	23	360	30	196	95	17,4	8	M 6	18	0,3	4201-024001-000000
25	50	26	17	20	78	31	68	26	62	23	380	30	189	95	17,4	8	M 6	18	0,3	4201-025001-000000
28	55	26	17	20	95	37	80	30	72	26	630	45	252	129	17,4	12	M 6	18	0,3	4201-028001-000000
30	55	26	17	20	95	37	80	30	72	26	680	45	236	129	17,4	12	M 6	18	0,3	4201-030001-000000
32	60	26	17	20	98	36	84	29	76	25	720	45	221	118	17,4	12	M 6	18	0,3	4201-032001-000000
35	60	26	17	20	98	36	84	29	76	25	790	45	202	118	17,4	12	M 6	18	0,3	4201-035001-000000
38	65	26	17	20	110	40	94	32	84	27	1050	57	233	136	17,4	15	M 6	18	0,4	4201-038001-000000
40	65	26	17	20	110	40	94	32	84	27	1150	57	221	136	17,4	15	M 6	18	0,4	4201-040001-000000
42	75	32	20	24	132	49	111	38	99	32	1750	83	261	146	42,2	12	M 8	22	0,6	4201-042001-000000
45	75	32	20	24	132	49	111	38	99	32	1850	83	244	146	42,2	12	M 8	22	0,5	4201-045001-000000
48	80	32	20	24	135	48	116	38	104	32	2000	83	229	137	42,2	12	M 8	22	0,6	4201-048001-000000
50	80	32	20	24	135	48	116	38	104	32	2050	83	219	137	42,2	12	M 8	22	0,6	4201-050001-000000
55	85	32	20	24	151	53	128	42	114	35	2800	100	249	162	42,2	15	M 8	22	0,6	4201-055001-000000
60	90	32	20	24	154	52	132	41	118	34	3100	100	229	153	42,2	15	M 8	22	0,7	4201-060001-000000
65	95	32	20	24	157	51	136	41	123	34	3400	100	211	145	42,2	15	M 8	22	0,8	4201-065001-000000
70	110	38	24	28	194	66	165	52	147	43	5800	160	261	166	83	15	M 10	25	1,3	4201-070001-000000
75	115	38	24	28	197	65	169	51	151	42	6200	160	243	159	83	15	M 10	25	1,2	4201-075001-000000
80	120	38	24	28	200	64	173	51	156	42	6600	160	228	152	83	15	M 10	25	1,4	4201-080001-000000
85	125	38	24	28	204	64	177	50	161	42	7000	160	215	146	83	15	M 10	25	1,4	4201-085001-000000
90	130	38	24	28	208	63	182	50	165	42	7400	160	203	141	83	15	M 10	25	1,5	4201-090001-000000
95	135	38	24	28	225	69	195	54	176	45	9400	200	230	162	83	18	M 10	25	1,6	4201-095001-000000
100	145	44	26	32	245	76	212	60	191	49	12100	240	247	171	144	15	M 12	30	2,2	4201-100001-000000
110	155	44	26	32	252	75	220	59	200	49	13500	240	225	160	144	15	M 12	30	2,3	4201-110001-000000
120	165	44	26	32	265	76	233	60	212	50	15500	260	220	160	144	16	M 12	30	2,4	4201-120001-000000
130	180	50	34	38	288	88	252	70	229	59	21000	320	194	140	144	20	M 12	35	3,5	4201-130001-000000
140	190	50	34	38	304	91	266	72	242	60	25000	350	198	146	144	22	M 12	35	3,8	4201-140001-000000
150	200	50	34	38	321	95	281	75	256	62	29000	390	202	152	144	24	M 12	35	4,0	4201-150001-000000
160	210	50	34	38	337	98	295	77	269	64	33500	420	205	156	144	26	M 12	35	4,4	4201-160001-000000
170	225	58	38	44	360	106	316	84	287	69	41500	490	200	151	229	22	M 14	40	5,7	4201-170001-000000
180	235	58	38	44	378	110	331	86	301	71	47500	530	206	158	229	24	M 14	40	6,0	4201-180001-000000
190	250	66	46	52	400	121	350	96	318	80	59000	620	188	143	229	28	M 14	45	8,0	4201-190001-000000
200	260	66	46	52	417	125	365	99	332	82	66500	660	192	147	229	30	M 14	45	8,2	4201-200001-000000
220	285	72	50	56	457	136	400	108	364	90	87500	800	192	149	354	26	M 16	50	11,0	4201-220001-000000
240	305	72	50	56	494	145	432	114	393	94	110000	920	203	160	354	30	M 16	50	12,2	4201-240001-000000
260	325	72	50	56	530	153	463	119	421	98	135000	1050	213	170	354	34	M 16	50	13,2	4201-260001-000000
280	355	84	60	66	566	166	497	131	452	109	167000	1200	189	149	492	32	M 18	60	19,2	4201-280001-000000
300	375	84	60	66	604	175	529	137	481	113	201500	1350	198	159	492	36	M 18	60	20,5	4201-300001-000000
320	405	98	72	78	663	201	577	158	523	131	275500	1700	199	157	692	36	M 20	70	29,6	4201-320001-000000
340	425	98	72	78	678	199	595	157	542	131	293000	1700	187	150	692	36	M 20	70	31,1	4201-340001-000000
360	455	112	84	90	739	226	644	179	584	149	385500	2150	188	149	945	36	M 22	80	42,2	4201-360001-000000
380	475	112	84	90	754	224	661	177	603	148	407000	2150	179	143	945	36	M 22	80	44,0	4201-380001-000000
400	495	112	84	90	769	221	679	176	621	147	428500	2150	170	137	945	36	M 22	80	46,0	4201-400001-000000

Larger elements available on request.

Cone Clamping Elements RLK 250

centres the hub to the shaft
quick assembly, easy to release



Features

- Centres the hub to the shaft
- Radial flat height is particularly suitable for small hub outer diameters
- Quick assembly by central groove nut
- Easy to release
- Transmissible torque of 38 Nm up to 1 050 Nm
- For shaft diameters between 15 mm and 70 mm

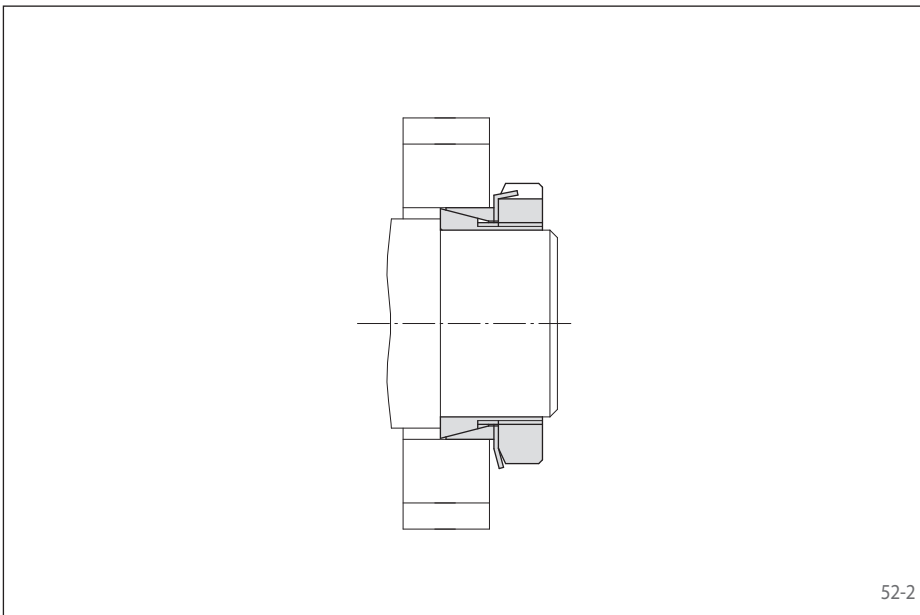

Application example

Backlash free connection of a drive wheel to a shaft with a Cone Clamping Element RLK 250. The central groove nut leads to a uniform displacement of the cone ring during clamping and thus achieves a centring that is sufficient for lower requirements. The central groove nut and the self-releasing cone ensure quick disassembly. Thus, a worn drive wheel can be replaced with the shortest of downtimes.

Transmissible torques and axial forces

The transmissible torques or axial forces listed on the following page are subject to the following tolerances, surface characteristics and material requirements. Please contact us in the case of deviations.

Tolerances

- h8 for shaft diameter d
- H8 for hub bore D

Surfaces

Average surface roughness at the contact surfaces between the shaft and the hub bore:
 $R_z = 10 \dots 25 \mu\text{m}$.

Materials

The following apply to the shaft and the hub:

- E-module $\geq 170 \text{ kN/mm}^2$

Installation

Please request our installation and operating instructions for Cone Clamping Elements RLK 250.

Simultaneous transmission of torque and axial force

The transmissible torques M which are shown in the tables apply for axial forces $F = 0 \text{ kN}$ and conversely, the indicated axial forces F apply to torques $M = 0 \text{ Nm}$. If torque and axial force are to be transmitted simultaneously, the transmissible torque and the transmissible axial force are reduced. Please refer to the technical points on pages 74 and 75.

Example for ordering

Cone Clamping Element RLK 250 for shaft diameter $d = 50 \text{ mm}$:

- RLK 250, size 50 x 62
Article number 4202-050001-000000

centres the hub to the shaft
quick assembly, easy to release

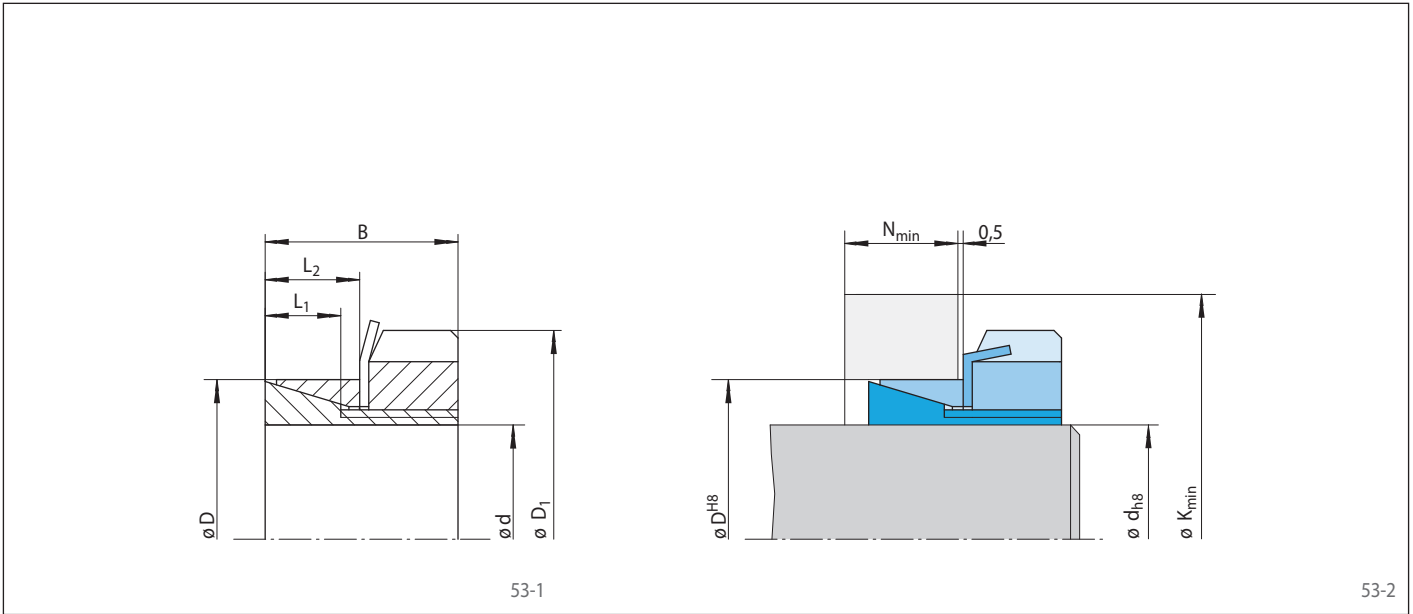

Dimensions												Technical Data						Article number	
Size		D ₁ mm	B mm	L ₁ mm	L ₂ mm	Yield strength R _e of the hub material [N/mm ²]						Transmissible torque or axial force		Contact pressure at		Groove nut Tightening torque M _S Nm	Size		Weight kg
d mm	D mm					200	320	500	M	F	P _W	P _N	M _S						
15	25	32	16,5	6,5	9,5	39	13	34	11	31	10	38	5	159	95	48	KM 4	0,050	4202-015001-000000
16	25	32	16,5	6,5	9,5	40	13	34	11	31	10	42	5	160	102	50	KM 4	0,048	4202-016001-000000
19	30	38	18,0	6,5	10,0	46	14	40	12	37	10	60	6	160	101	74	KM 5	0,080	4202-019001-000000
20	30	38	18,0	6,5	10,0	47	14	41	12	37	10	65	6	160	106	78	KM 5	0,070	4202-020001-000000
24	35	45	18,0	6,5	10,0	55	15	47	13	43	11	95	8	160	109	110	KM 6	0,100	4202-024001-000000
25	35	45	18,0	6,5	10,0	55	15	47	13	44	11	105	8	160	114	120	KM 6	0,090	4202-025001-000000
30	40	52	19,5	7,0	10,5	64	16	55	14	50	12	160	10	160	120	170	KM 7	0,130	4202-030001-000000
35	45	58	21,5	8,0	10,5	76	18	64	15	57	13	250	14	160	124	250	KM 8	0,170	4202-035001-000000
36	45	58	21,5	8,0	10,5	77	18	65	15	58	13	260	14	160	128	260	KM 8	0,150	4202-036001-000000
40	52	65	24,5	10,0	12,5	88	19	74	16	67	14	350	17	138	106	460	KM 9	0,240	4202-040001-000000
45	57	70	25,5	10,0	12,5	91	21	78	17	70	15	420	18	132	104	550	KM 10	0,270	4202-045001-000000
48	62	75	25,5	10,0	12,5	100	22	85	18	77	16	500	22	144	112	700	KM 11	0,320	4202-048001-000000
50	62	75	25,5	10,0	12,5	100	22	85	18	77	16	560	22	138	112	700	KM 11	0,280	4202-050001-000000
55	68	80	27,5	12,0	15,0	99	22	88	20	81	18	600	21	103	83	770	KM 12	0,360	4202-055001-000000
56	68	80	27,5	12,0	15,0	99	22	88	20	81	18	610	21	101	83	770	KM 12	0,340	4202-056001-000000
60	73	85	28,5	12,0	16,5	104	24	92	21	86	19	710	24	102	83	880	KM 13	0,390	4202-060001-000000
63	79	92	30,5	14,0	17,0	114	25	101	22	93	20	870	28	97	77	1100	KM 14	0,560	4202-063001-000000
65	79	92	30,5	14,0	17,0	114	25	101	22	93	20	900	28	94	77	1100	KM 14	0,520	4202-065001-000000
70	84	98	31,5	14,0	17,0	121	26	107	22	99	20	1050	30	95	79	1250	KM 15	0,600	4202-070001-000000

If the hub cannot be freely moved to the left, e.g. due to a shaft shoulder, the values for M, F, P_W and P_N are reduced by 37%. In this case, the required hub outer diameter K_{min} and the required hub width N_{min} may be lower than indicated.

centres the hub to the shaft
quick assembly



Features

- Centres the hub to the shaft
- Radial flat height is particularly suitable for small hub outer diameters
- Quick assembly by central groove nut
- Transmissible torque of 74 Nm up to 1 500 Nm
- For shaft diameters between 15 mm and 60 mm

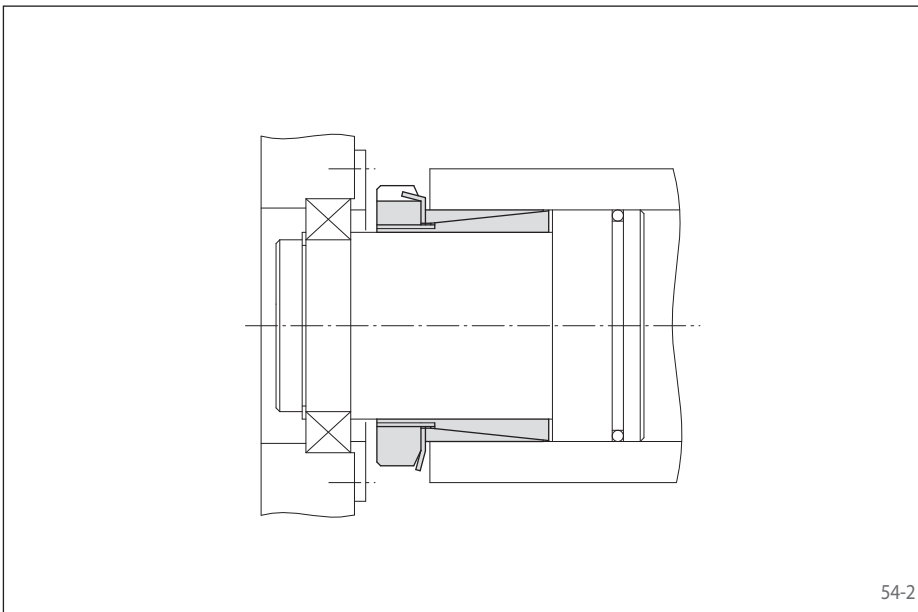

Application example

Backlash free connection of a hollow shaft with a Cone Clamping Element RLK 250 L. The Cone Clamping Element centres the hollow shaft on the shaft. Due to the flat radial height of the Cone Clamping Element, the hollow shaft can be designed thin walled.

Transmissible torques and axial forces

The transmissible torques or axial forces listed on the following page are subject to the following tolerances, surface characteristics and material requirements. Please contact us in the case of deviations.

Tolerances

- h8 for shaft diameter d
- H8 for hub bore D

Surfaces

Average surface roughness at the contact surfaces between the shaft and the hub bore:
 $R_z = 10 \dots 25 \mu\text{m}$.

Materials

The following apply to the shaft and the hub:

- E-module $\geq 170 \text{ kN/mm}^2$

Installation

Please request our installation and operating instructions for Cone Clamping Elements RLK 250 L.

Simultaneous transmission of torque and axial force

The transmissible torques M which are shown in the tables apply for axial forces $F = 0 \text{ kN}$ and conversely, the indicated axial forces F apply to torques $M = 0 \text{ Nm}$. If torque and axial force are to be transmitted simultaneously, the transmissible torque and the transmissible axial force are reduced. Please refer to the technical points on pages 74 and 75.

Example for ordering

Cone Clamping Element RLK 250 L for shaft diameter $d = 50 \text{ mm}$:

- RLK 250 L, size 50 x 60
Article number 4202-050002-000000

centres the hub to the shaft
quick assembly

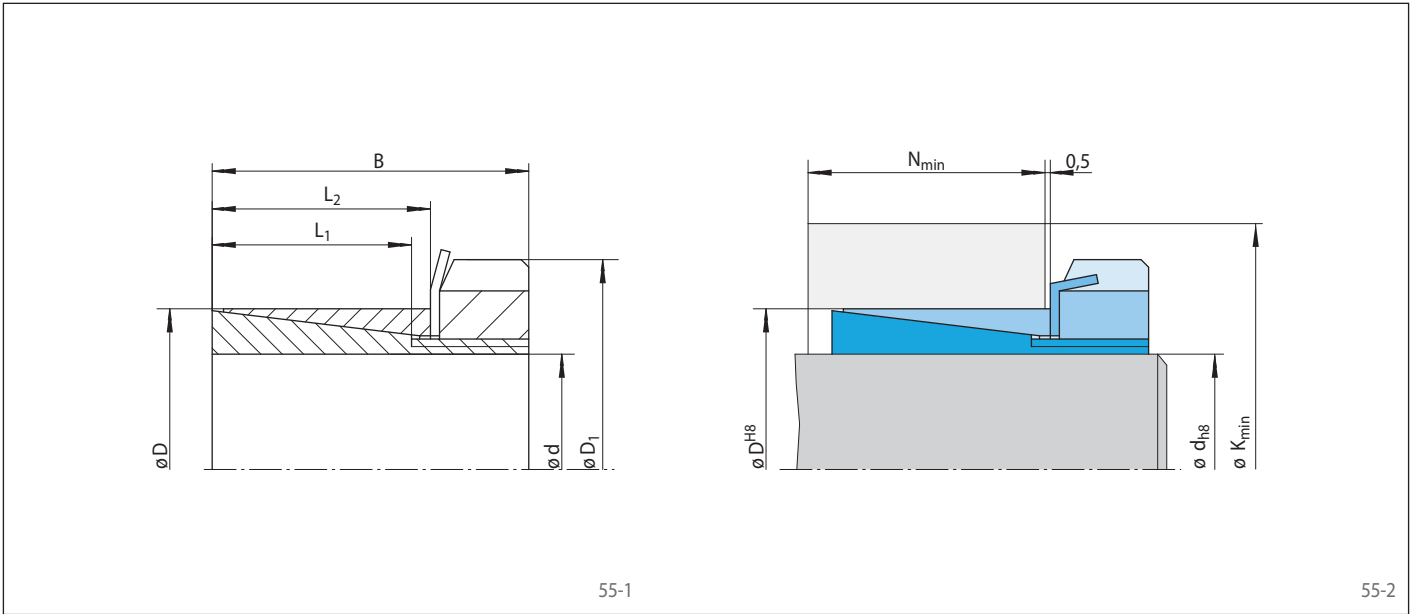

Dimensions												Technical Data						Article number	
Size		D ₁ mm	B mm	L ₁ mm	L ₂ mm	Yield strength R _e of the hub material [N/mm ²]						Transmissible torque or axial force		Contact pressure at		Groove nut			Weight kg
d mm	D mm					200	320	500	M	F	P _W	P _N	Tightening torque M _S Nm	Size					
15	25	32	29	17	23	40	25	34	23	30	23	74	9,8	120	72	53	KM 4	0,08	4202-015001-A00000
16	25	32	29	17	23	41	25	34	23	31	23	80	10	120	76	56	KM 4	0,07	4202-016001-A00000
17	25	38	31	18	24	42	27	35	24	31	24	100	11	120	81	72	KM 5	0,13	4202-017001-A00000
18	30	38	31	18	24	47	27	40	24	36	24	110	12	120	72	83	KM 5	0,12	4202-018002-000000
19	30	38	31	18	24	48	27	41	24	37	24	120	12	120	76	90	KM 5	0,12	4202-019001-A00000
20	30	38	31	18	24	49	28	41	24	37	24	130	13	120	80	100	KM 5	0,11	4202-020001-A00000
22	35	45	35	21	26	57	30	47	27	43	26	180	16	120	75	130	KM 6	0,18	4202-022001-A00000
24	35	45	35	21	26	60	31	48	28	43	26	230	19	119	82	160	KM 6	0,16	4202-024001-A00000
25	35	45	35	21	26	61	31	49	28	44	26	250	16	120	85	160	KM 6	0,15	4202-025001-A00000
28	40	52	35	22	27	69	33	55	29	50	27	330	23	120	84	220	KM 7	0,24	4202-028001-A00000
30	40	52	35	22	27	72	34	57	30	50	27	380	20	120	90	230	KM 7	0,21	4202-030004-000000
35	45	58	42	28	31,5	90	39	68	34	58	32	460	26	120	93	320	KM 8	0,26	4202-035001-A00000
40	50	65	44	28	34	99	40	75	34	65	34	640	32	120	96	440	KM 9	0,33	4202-040002-000000
45	55	70	45	28	34	105	41	82	35	71	34	760	33	120	98	550	KM 10	0,39	4202-045001-A00000
50	60	75	46	28	34	117	42	91	36	78	34	930	37	120	100	660	KM 11	0,40	4202-050002-000000
55	65	80	47	28	34	118	41	94	35	82	34	1100	40	120	97	770	KM 12	0,44	4202-055002-000000
60	70	85	52	28	38,5	125	42	101	39	88	39	1500	50	120	97	890	KM 13	0,55	4202-060001-A00000

If the hub cannot be freely moved to the left, e.g. due to a shaft shoulder, the values for M, F, P_W and P_N are reduced by 37%. In this case, the required hub outer diameter K_{min} and the required hub width N_{min} may be lower than indicated.



56-1

Features

- For individual clamping connections
- Compact design
- Transmissible torque of 7,3 Nm up to 27 393 Nm
- For shaft diameters between 10 mm and 200 mm

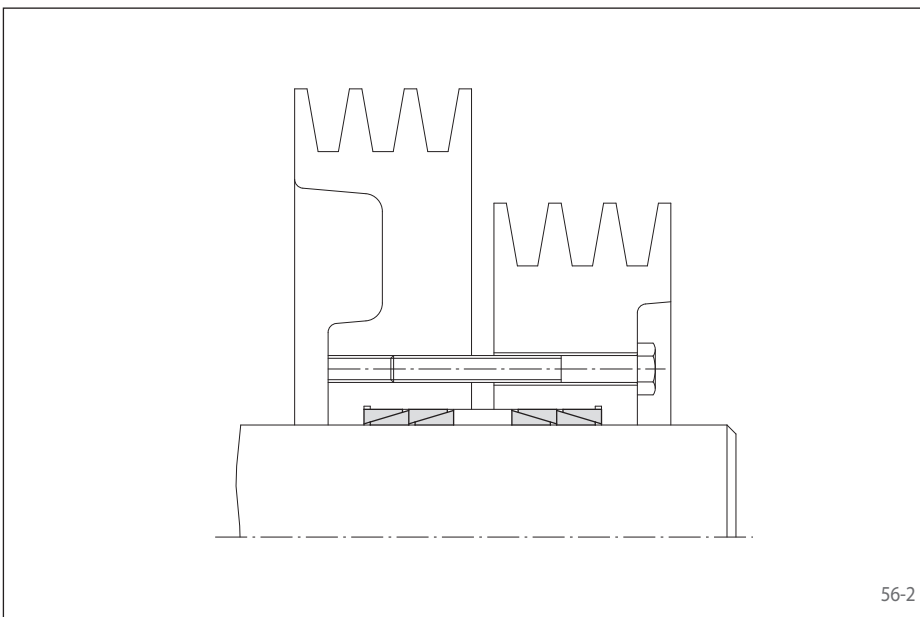

56-2

Application example

Backlash free connection of two V-belt pulleys with two Cone Clamping Elements RLK 300 each. In this assembly, the screw force is used on both sides. By this, both packages with two Cone Clamping Elements each are charged with the preload force. Due to the double arrangement of the Cone Clamping Elements, the transmissible torque is increased. Because of the recessed hub, separate pressure flanges are not required. This makes the solution very cost-effective.

Transmissible torques and axial forces

The transmissible torques or axial forces listed on pages 58 and 59 are subject to the following tolerances, surface characteristics, materials and preload force requirement. Please contact us in the case of deviations.

Tolerances

d		Hub bore ISO	Shaft ISO
> mm	≤ mm		
10	40	H7	h6
40	200	H8	h8

Surfaces

Average surface roughness at the contact surfaces between the shaft and the hollow shaft $R_z = 4 \dots 10 \mu\text{m}$.

Materials

The following apply to the shaft and the hub:

- E-module $\geq 170 \text{ kN/mm}^2$

Preload force

The preload force is achieved by the clamping screws provided by the customer. The preload force E_1 or E_2 stated in the table may be increased or decreased according to the technical notes on page 74.

Installation

Please request our installation and operating instructions for Cone Clamping Elements RLK 300.

Simultaneous transmission of torque and axial force

The transmissible torques M which are shown in the tables apply for axial forces $F = 0 \text{ kN}$ and conversely, the indicated axial forces F apply to torques $M = 0 \text{ Nm}$. If torque and axial force are to be transmitted simultaneously, the transmissible torque and the transmissible axial force are reduced. Please refer to the technical points on pages 74 and 75.

Example for ordering

Cone Clamping Element RLK 300 for shaft diameter $d = 50 \text{ mm}$:

- RLK 300, size 50 x 57
Article number 4203-050001-000000

for individual clamping connections

Installation case 1

The adjusted axial position of the hub is not changed during clamping. The preload force E_1 must be provided for.

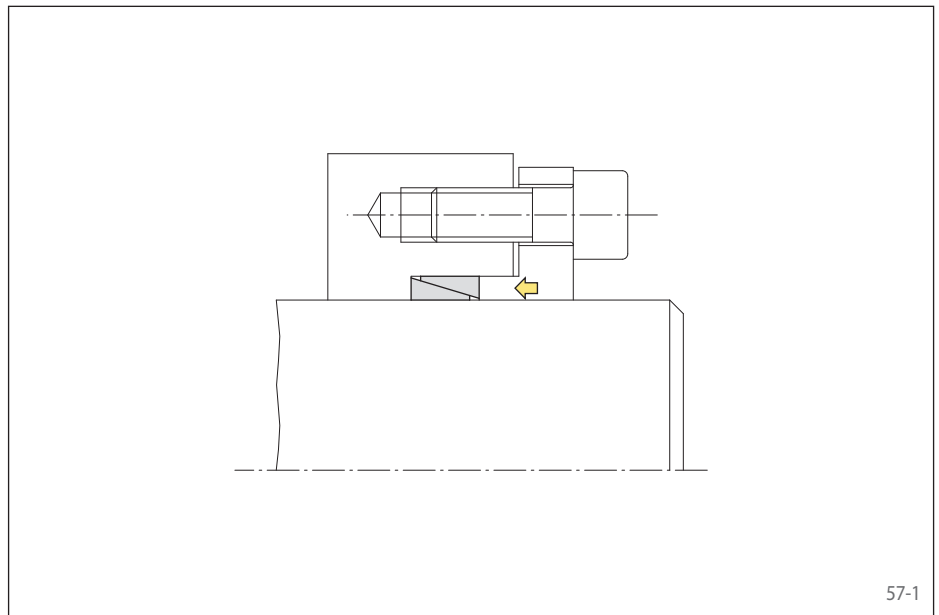

Installation case 2

During clamping, the hub is displaced slightly to the right compared to the shaft. The preload force E_2 must be provided for. The connection can easily be released when the Cone Clamping Element is assembled according to figure 57-2.

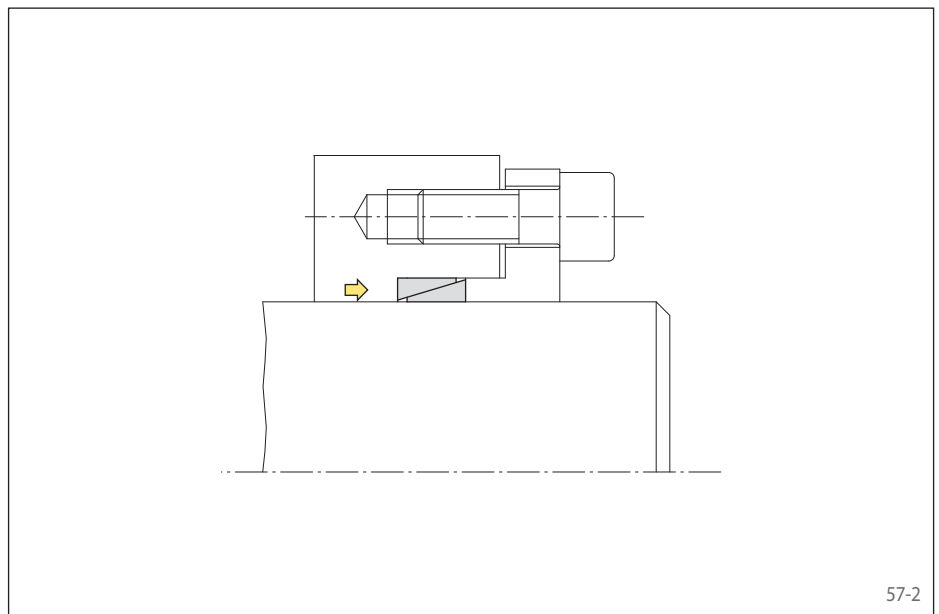

Double Arrangement

A double arrangement of two Cone Clamping Elements must be built according to installation case 2. The transmissible torque or axial force are not doubled compared to the values for M or F listed in the tables but are increased by 55%. The preload force E_1 must be provided for. The hub stress σ_V must be verified (page 75).

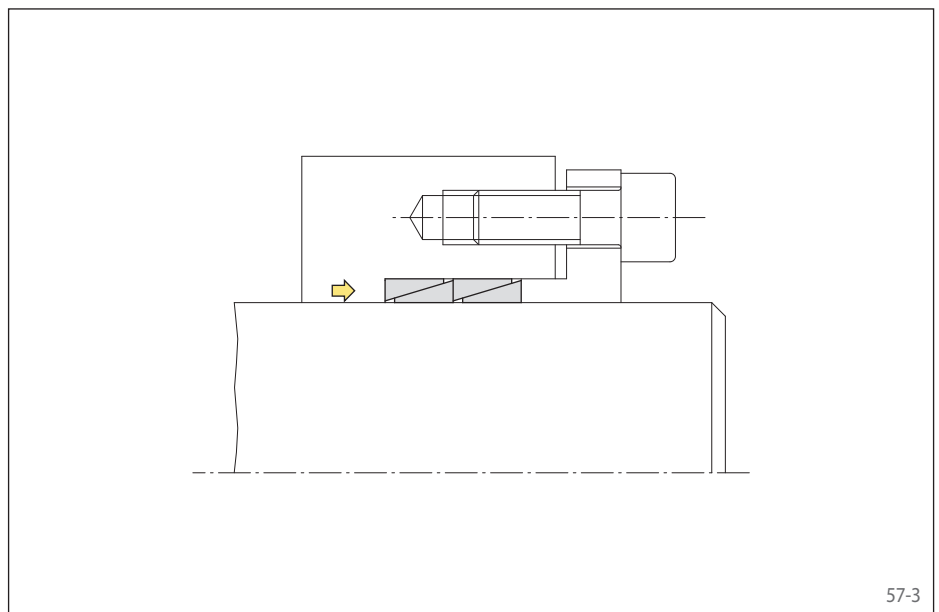

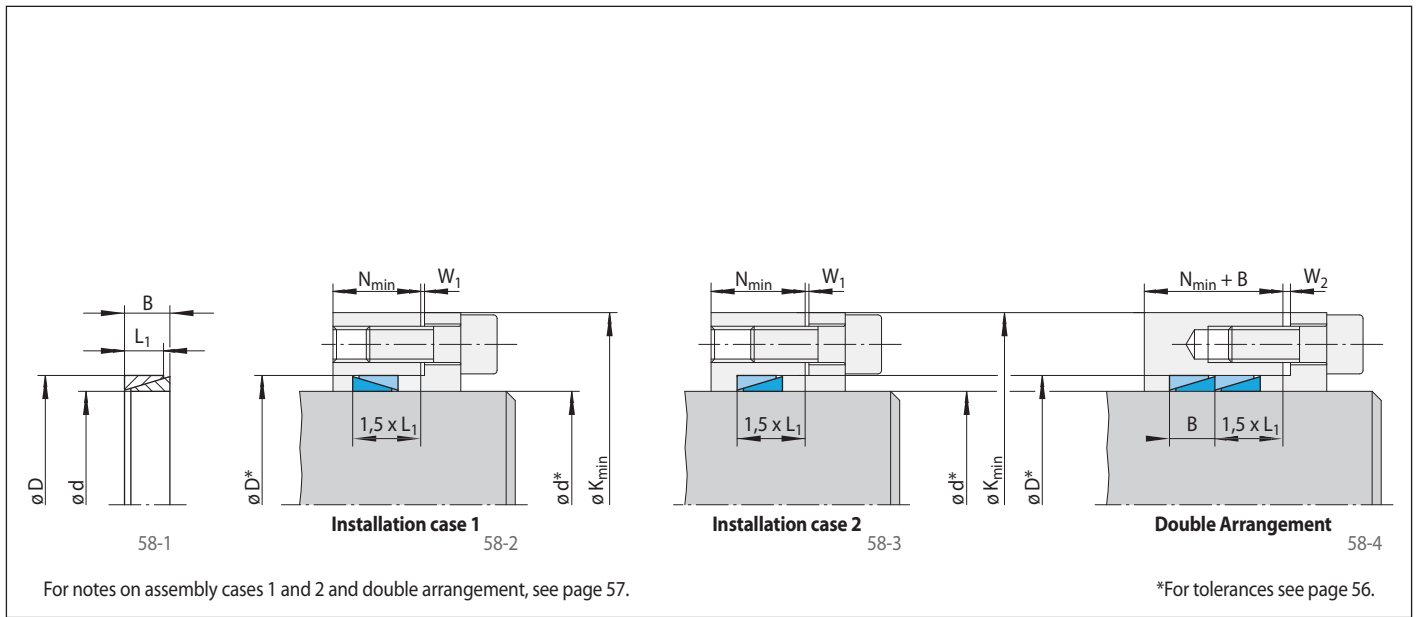

Size		Dimensions										Technical Data				Preload force		Weight	Article number
d	D	B	L ₁	W ₁	W ₂	Yield strength R _e of the hub material [N/mm ²]						Transmissible torque or axial force		Contact pressure at		E ₁	E ₂	kg	
mm	mm	mm	mm	mm	mm	200		320		500		M	F	Shaft	Hub	kN	kN		
						K _{min}	N _{min}	K _{min}	N _{min}	K _{min}	N _{min}	Nm	kN	N/mm ²	N/mm ²				
10	13	4,5	3,7	3	3	19	7,4	17	7,0	16	6,5	7,3	1,4	120	92	10,1	8,4	0,002	4203-010001-000000
12	15	4,5	3,7	3	3	22	7,4	19	7,0	18	6,5	10,5	1,7	120	96	11,6	9,5	0,002	4203-012001-000000
13	16	4,5	3,7	3	3	23	7,4	21	7,0	19	6,5	12,3	1,8	120	98	12,4	10,1	0,002	4203-013001-000000
14	18	6,3	5,3	3	4	26	10,6	23	10,1	22	9,3	20,4	2,9	120	93	20,0	16,5	0,005	4203-014001-000000
15	19	6,3	5,3	3	4	28	10,6	25	10,1	23	9,3	23,5	3,1	120	95	21,1	17,4	0,005	4203-015001-000000
16	20	6,3	5,3	3	4	29	10,6	26	10,1	24	9,3	26,0	3,3	120	96	22,2	18,2	0,005	4203-016001-000000
17	21	6,3	5,3	3	4	31	10,6	27	10,1	25	9,3	30,0	3,5	120	97	23,3	19,1	0,006	4203-017001-000000
18	22	6,3	5,3	3	4	32	10,6	28	10,1	26	9,3	33,0	3,7	120	98	24,4	19,9	0,006	4203-018001-000000
19	24	6,3	5,3	3	4	34	10,6	31	10,1	29	9,3	37,7	3,9	120	95	26,7	21,9	0,007	4203-019001-000000
20	25	6,3	5,3	3	4	36	10,6	32	10,1	30	9,3	41,7	4,1	120	96	27,7	22,8	0,008	4203-020001-000000
22	26	6,3	5,3	3	4	38	10,6	33	10,1	31	9,3	50,0	4,5	120	102	28,8	23,4	0,008	4203-022001-000000
24	28	6,3	5,3	3	4	40	10,6	36	10,1	33	9,3	60,1	5,0	120	103	31,0	25,1	0,008	4203-024001-000000
25	30	6,3	5,3	3	4	43	10,6	38	10,1	35	9,3	65,2	5,2	120	100	33,2	27,1	0,009	4203-025001-000000
28	32	6,3	5,3	3	4	46	10,6	41	10,1	38	9,3	81,8	5,8	120	105	35,4	28,6	0,010	4203-028001-000000
30	35	6,3	5,3	3	4	49	10,6	44	10,1	41	9,3	93,9	6,2	120	103	38,7	31,4	0,010	4203-030001-000000
32	36	6,3	5,3	3	4	51	10,6	45	10,1	42	9,3	107	6,6	120	107	39,8	32,0	0,012	4203-032001-000000
35	40	7	6,0	3	4	56	12,0	50	11,4	47	10,5	145	8,2	120	105	50,0	40,4	0,017	4203-035001-000000
36	42	7	6,0	4	5	58	12,0	52	11,4	49	10,5	153	8,5	120	103	52,6	42,7	0,020	4203-036001-000000
38	44	7	6,0	4	5	61	12,0	55	11,4	51	10,5	171	8,9	120	104	55,1	44,6	0,020	4203-038001-000000
40	45	8	6,6	4	5	64	13,2	57	12,5	53	11,6	208	10,3	120	107	61,9	49,9	0,020	4203-040001-000000
42	48	8	6,6	4	5	67	13,2	60	12,5	56	11,6	229	10,9	120	105	66,1	53,4	0,028	4203-042001-000000
45	52	10	8,6	4	5	73	17,2	65	16,3	61	15,1	343	15,2	120	104	93,3	75,5	0,042	4203-045001-000000
48	55	10	8,6	4	5	77	17,2	69	16,3	65	15,1	390	16,2	120	105	98,6	79,7	0,045	4203-048001-000000
50	57	10	8,6	4	5	80	17,2	71	16,3	67	15,1	423	16,9	120	105	102	82,6	0,047	4203-050001-000000
55	62	10	8,6	4	5	86	17,2	77	16,3	72	15,1	512	18,6	120	106	111	89,6	0,050	4203-055001-000000
60	68	12	10,4	4	5	95	20,8	85	19,8	80	18,2	737	24,5	120	106	148	119	0,072	4203-060001-000000
65	73	12	10,4	4	5	102	20,8	91	19,8	85	18,2	865	26,6	120	107	158	128	0,079	4203-065001-000000
70	79	14	12,2	4	5	111	24,4	99	23,2	93	21,4	1176	33,6	120	106	201	162	0,111	4203-070001-000000
75	84	14	12,2	4	5	117	24,4	105	23,2	98	21,4	1351	36,0	120	107	214	172	0,120	4203-075001-000000
80	91	17	15,0	5	6	128	30,0	114	28,5	107	26,3	1889	47,2	120	105	285	230	0,190	4203-080001-000000
85	96	17	15,0	5	6	134	30,0	120	28,5	112	26,3	2133	50,1	120	106	300	242	0,200	4203-085001-000000
90	101	17	15,0	5	6	141	30,0	126	28,5	118	26,3	2391	53,1	120	107	316	254	0,220	4203-090001-000000
95	106	17	15,0	5	6	147	30,0	132	28,5	124	26,3	2664	56,0	120	108	332	267	0,230	4203-095001-000000
100	114	21	18,7	5	6	159	37,4	142	35,5	133	32,7	3680	73,6	120	105	445	359	0,380	4203-100001-000000

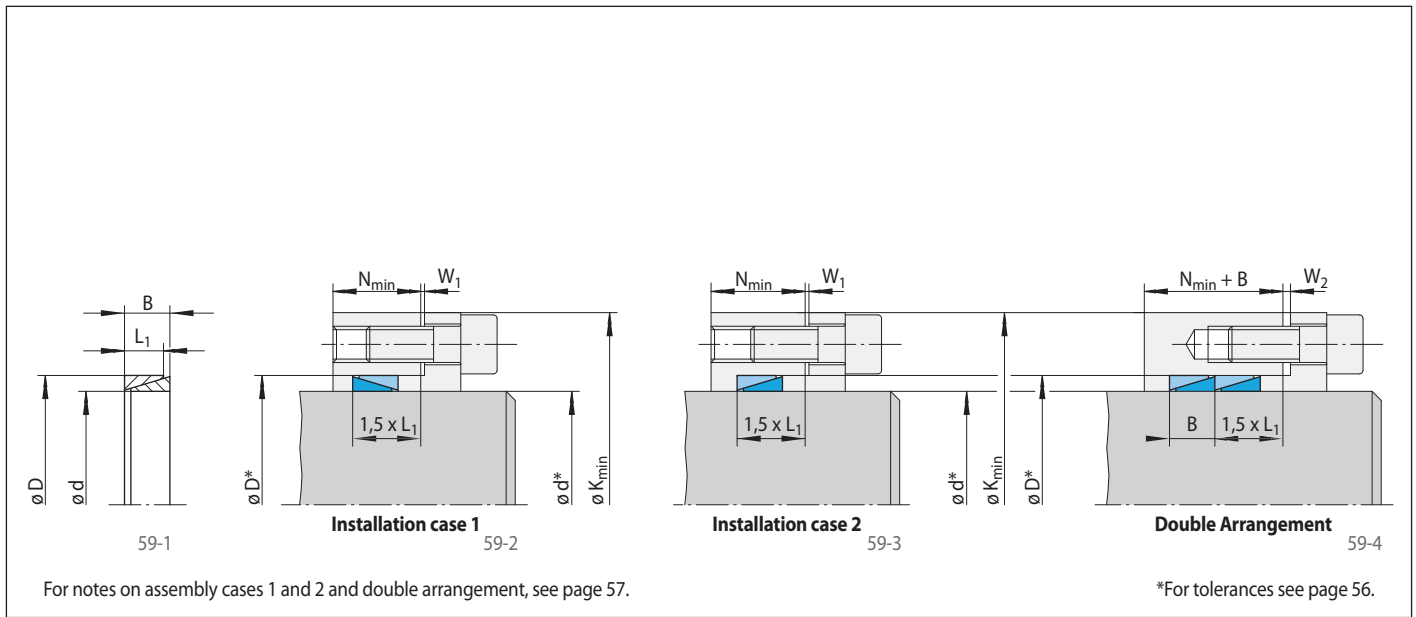

Size		Dimensions										Technical Data				Article number			
d mm	D mm	B mm	L ₁ mm	W ₁ mm	W ₂ mm	Yield strength R _e of the hub material [N/mm ²]						Transmissible torque or axial force		Contact pressure at			Preload force		Weight
						200		320		500		M Nm	F kN	Shaft P _W N/mm ²	Hub P _N N/mm ²	E ₁ kN	E ₂ kN	kg	
110	124	21	18,7	5	6	172	37,4	154	35,5	145	32,7	4453	80,9	120	106	483	389	0,410	4203-110001-000000
120	134	21	18,7	5	6	185	37,4	166	35,5	156	32,7	5299	88,3	120	107	516	415	0,452	4203-120001-000000
130	148	28	25,3	6	7	205	50,6	184	48,1	173	44,3	8414	129	120	105	762	616	0,847	4203-130001-000000
140	158	28	25,3	6	7	218	50,6	196	48,1	184	44,3	9758	139	120	106	808	652	0,910	4203-140001-000000
150	168	28	25,3	6	7	231	50,6	207	48,1	195	44,3	11202	149	120	107	855	689	0,967	4203-150001-000000
160	178	28	25,3	6	7	243	50,6	219	48,1	206	44,3	12746	159	120	108	902	726	1,020	4203-160001-000000
170	191	33	30,0	7	8	262	60,0	236	57,0	222	52,5	17062	200	120	107	1138	917	1,500	4203-170001-000000
180	201	33	30,0	7	8	274	60,0	247	57,0	233	52,5	19128	212	120	107	1195	962	1,580	4203-180001-000000
190	211	33	30,0	7	9	287	60,0	259	57,0	244	52,5	21312	224	120	108	1252	1007	1,690	4203-190001-000000
200	224	38	34,8	7	9	305	69,6	276	66,1	260	60,9	27393	273	120	107	1530	1233	2,320	4203-200001-000000

centres the hub to the shaft
for small shaft diameters

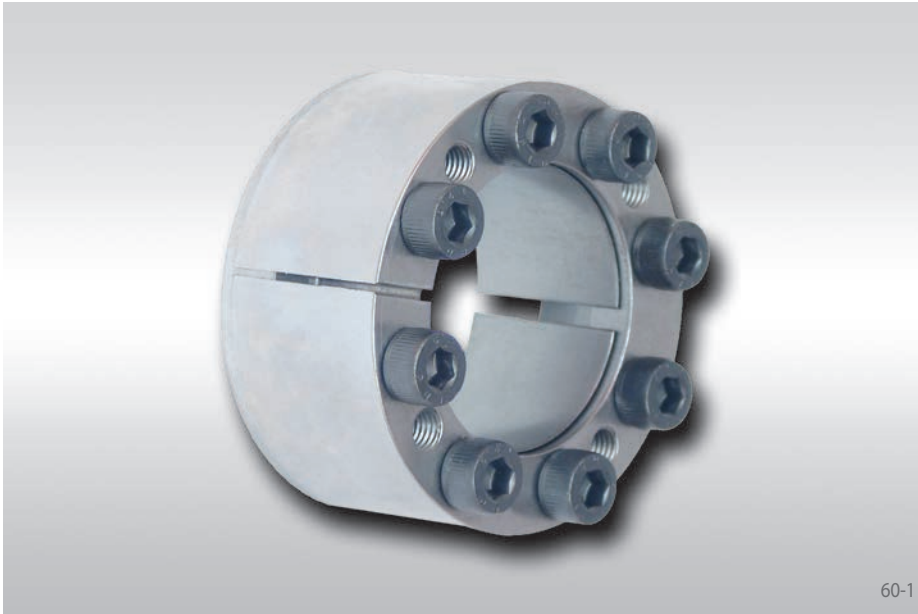

60-1

Features

- Centres the hub to the shaft
- Transmissible torque of 7,2 Nm up to 2200 Nm
- For shaft diameters between 5 mm and 50 mm

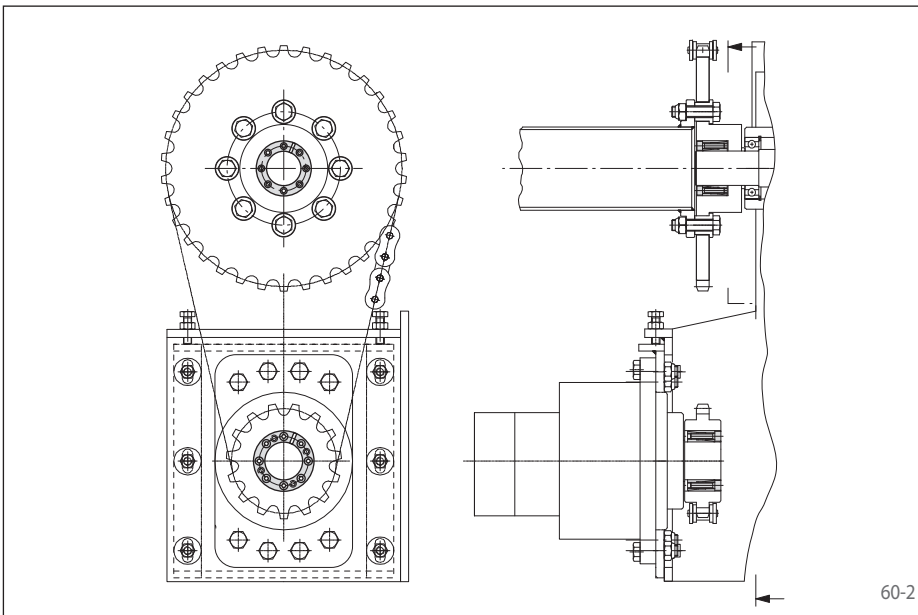

60-2

Application example

Backlash free connection of sprocket wheels to shafts in the drive of an industrial door with Cone Clamping Elements RLK 350. The Cone Clamping Elements centre the sprocket wheels on the shaft. The sprocket wheels can be easily aligned in axial and circumferential directions during assembly.

Transmissible torques and axial forces

The transmissible torques or axial forces listed on the following page are subject to the following tolerances, surface characteristics and material requirements. Please contact us in the case of deviations.

Tolerances

- h8 for shaft diameter d
- H8 for hub bore D

Surfaces

Average surface roughness at the contact surfaces between the shaft and the hub bore:
 $R_z = 10 \dots 25 \mu\text{m}$.

Materials

The following apply to the shaft and the hub:

- E-module $\geq 170 \text{ kN/mm}^2$

Installation

If the hub cannot be freely moved the values for M, F, P_W and P_N are reduced by 37%. K_{min} can be decreased. See the technical notes on page 75.

Please request our installation and operating instructions for Cone Clamping Elements RLK 350.

Simultaneous transmission of torque and axial force

The transmissible torques M which are shown in the tables apply for axial forces $F = 0 \text{ kN}$ and conversely, the indicated axial forces F apply to torques $M = 0 \text{ Nm}$. If torque and axial force are to be transmitted simultaneously, the transmissible torque and the transmissible axial force are reduced. Please refer to the technical points on pages 74 and 75.

Example for ordering

Cone Clamping Element RLK 350 for shaft diameter $d = 50 \text{ mm}$:

- RLK 350, size 50 x 80
Article number 4208-050001-000000

centres the hub to the shaft
for small shaft diameters

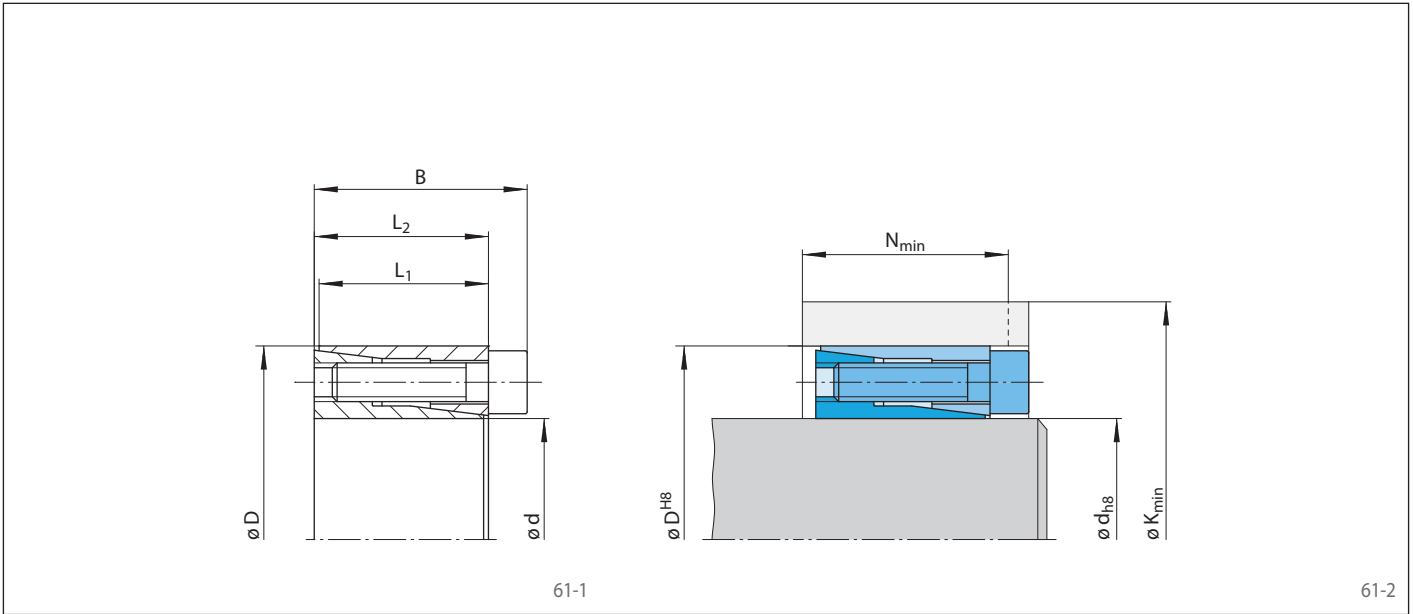

Dimensions												Technical Data							Article number	
Size		B mm	L ₁ mm	L ₂ mm	Yield strength R _e of the hub material [N/mm ²]						Transmissible torque or axial force		Contact pressure at		Clamping screws			Weight kg		
d mm	D mm				200		320		500		M Nm	F kN	Shaft P _w N/mm ²	Hub P _N N/mm ²	Tightening torque M _s Nm	Num- ber	Size			Length mm
5	16	13,5	10	11	22	13	20	12	19	12	7,2	2,9	153	48	1,1	3	M 2,5	10	0,010	4208-005001-000000
6	16	13,5	10	11	22	13	20	12	19	12	8,6	2,9	127	48	1,1	3	M 2,5	10	0,012	4208-006001-000000
6,35	16	13,5	10	11	22	13	20	12	19	12	9,1	2,9	120	48	1,1	3	M 2,5	10	0,012	4208-006002-000000
7	17	13,5	10,5	11	23	14	21	13	20	12	10	2,9	104	43	1,1	3	M 2,5	10	0,013	4208-007001-000000
8	18	13,5	10,5	11	24	14	22	13	21	12	11	2,9	91	41	1,1	3	M 2,5	10	0,015	4208-008001-000000
9	20	15,5	12,5	13	26	16	24	15	23	14	17	3,8	91	41	1,1	4	M 2,5	12	0,020	4208-009001-000000
9,53	20	15,5	12,5	13	26	16	24	15	23	14	18	3,8	86	41	1,1	4	M 2,5	12	0,019	4208-009002-000000
10	20	15,5	12,5	13	26	16	24	15	23	14	19	3,8	82	41	1,1	4	M 2,5	12	0,019	4208-010001-000000
11	22	15,5	12,5	13	28	16	26	15	25	14	21	3,8	74	37	1,1	4	M 2,5	12	0,024	4208-011001-000000
12	22	15,5	12,5	13	28	16	26	15	25	14	23	3,8	68	37	1,1	4	M 2,5	12	0,022	4208-012001-000000
14	26	20	16,5	17	33	20	30	19	30	19	42	5,9	69	37	2,1	4	M 3	16	0,039	4208-014001-000000
15	28	20	16,5	17	35	20	32	19	32	19	45	5,9	64	35	2,1	4	M 3	16	0,044	4208-015001-000000
16	32	21	16,5	17	44	23	39	20	37	19	85	11	108	54	5,1	4	M 4	16	0,067	4208-016001-000000
17	35	25	20,5	21	45	26	41	24	40	23	91	11	82	40	5,1	4	M 4	20	0,090	4208-017001-000000
18	35	25	20,5	21	45	26	41	24	40	23	96	11	77	40	5,1	4	M 4	20	0,087	4208-018001-000000
19	35	25	20,5	21	45	26	41	24	40	23	100	11	73	40	5,1	4	M 4	20	0,083	4208-019001-000000
20	38	26	20,5	21	54	29	48	26	44	24	170	17	110	58	10,0	4	M 5	20	0,100	4208-020001-000000
22	40	26	20,5	21	55	28	49	25	46	24	190	17	100	55	10,0	4	M 5	20	0,110	4208-022001-000000
24	47	32	25	26	65	34	58	31	54	29	290	24	108	55	17,4	4	M 6	25	0,200	4208-024001-000000
25	47	32	25	26	65	34	58	31	54	29	300	24	104	55	17,4	4	M 6	25	0,190	4208-025001-000000
28	50	32	25	26	77	39	66	33	60	30	510	36	139	78	17,4	6	M 6	25	0,180	4208-028001-000000
30	55	32	25	26	81	38	71	33	65	30	550	36	129	71	17,4	6	M 6	25	0,220	4208-030001-000000
32	55	32	25	26	81	38	71	33	65	30	580	36	121	71	17,4	6	M 6	25	0,270	4208-032001-000000
35	60	37	30	31	82	41	73	37	69	35	640	36	93	54	17,4	6	M 6	30	0,250	4208-035001-000000
38	65	37	30	31	93	44	83	39	76	36	920	49	114	67	17,4	8	M 6	30	0,360	4208-038001-000000
40	65	37	30	31	93	44	83	39	76	36	970	49	108	67	17,4	8	M 6	30	0,430	4208-040001-000000
45	75	44	35	36	121	58	103	49	93	44	2000	89	150	90	42,2	8	M 8	35	0,630	4208-045001-000000
50	80	44	35	36	124	57	107	49	97	44	2200	89	135	85	42,2	8	M 8	35	0,700	4208-050001-000000

Cone Clamping Elements RLK 402

centres the hub to the shaft
highest transmissible torques

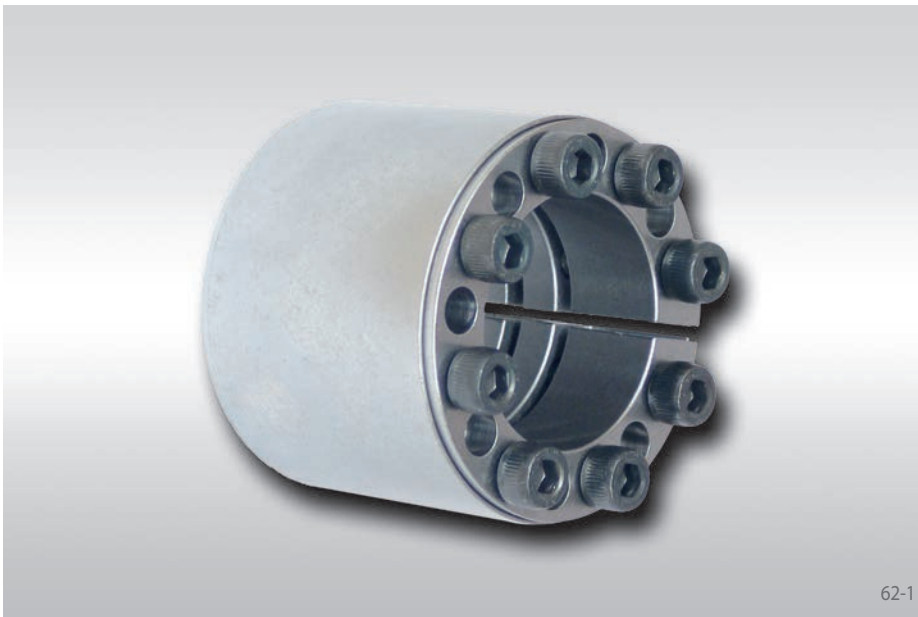

Features

- Centres the hub to the shaft
- Highest transmissible torques
- For heavy duty applications
- No axial displacement between hub and shaft during clamping procedure
- Transmissible torque of 840 Nm up to 414 500 Nm
- For shaft diameters between 25 mm and 300 mm

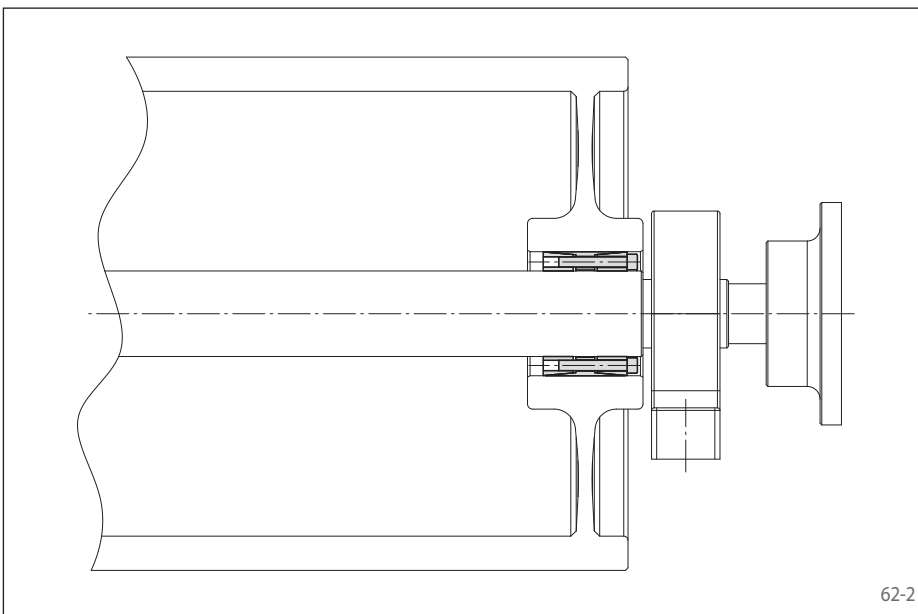

Application example

Backlash free attachment of a belt drum to the drive shaft of a conveyor belt with a Cone Clamping Element RLK 402. The Cone Clamping Element can be used to transmit all acting loads of a driven belt drum. It centres the belt drum on the drive shaft. As no axial shift occurs during the clamping process, the axial position of the belt drum in relation to the drive shaft remains unchanged.

Transmissible torques and axial forces

The transmissible torques or axial forces listed on the following page are subject to the following tolerances, surface characteristics and material requirements. Please contact us in the case of deviations.

Tolerances

- h8 for shaft diameter d
- H8 for hub bore D

Surfaces

Average surface roughness at the contact surfaces between the shaft and the hub bore:
 $R_z = 10 \dots 25 \mu\text{m}$.

Materials

The following apply to the shaft and the hub:

- E-module $\geq 170 \text{ kN/mm}^2$

Installation

Please request our installation and operating instructions for Cone Clamping Elements RLK 402.

Simultaneous transmission of torque and axial force

The transmissible torques M which are shown in the tables apply for axial forces $F = 0 \text{ kN}$ and conversely, the indicated axial forces F apply to torques $M = 0 \text{ Nm}$. If torque and axial force are to be transmitted simultaneously, the transmissible torque and the transmissible axial force are reduced. Please refer to the technical points on pages 74 and 75.

Example for ordering

Cone Clamping Element RLK 402 for shaft diameter $d = 100 \text{ mm}$:

- RLK 402, size 100 x 145
Article number 4205-100201-000000

centres the hub to the shaft
highest transmissible torques

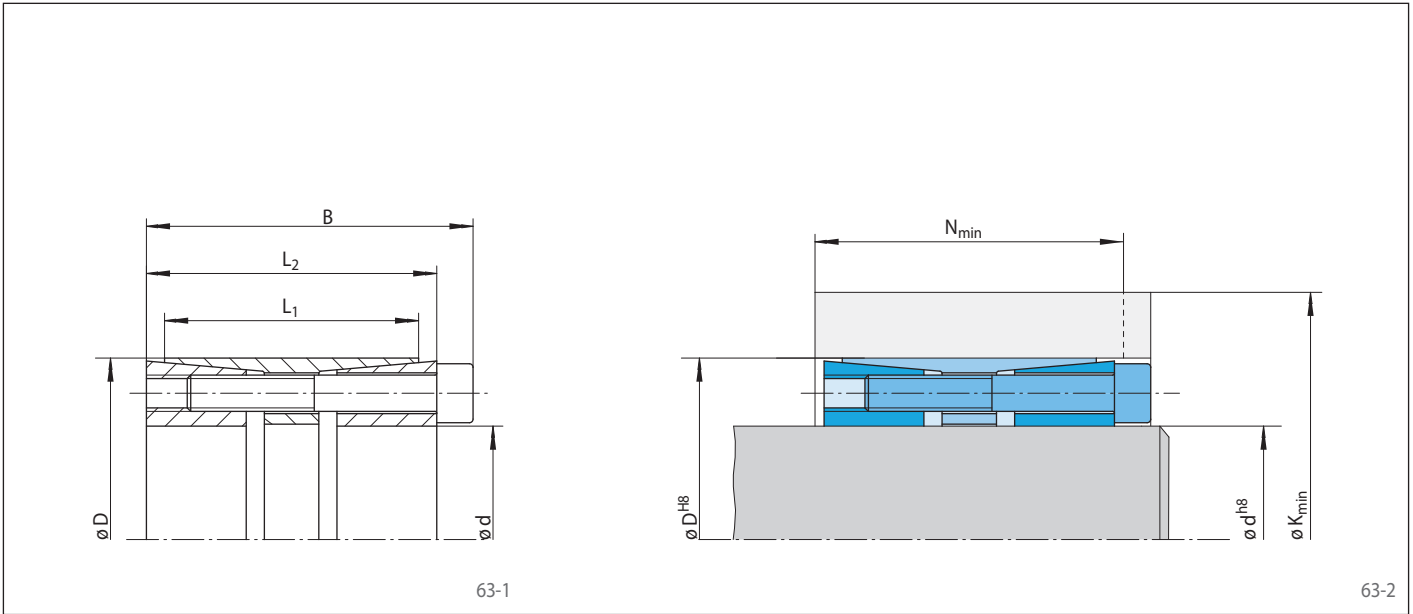

Dimensions												Technical Data								Article number
Size		Yield strength R_e of the hub material [N/mm ²]				Transmissible torque or axial force		Contact pressure at		Clamping screws				Weight						
d mm	D mm	B mm	L ₁ mm	L ₂ mm	200		320		500		Shaft	Hub	Tightening torque		Number	Size	Length	kg		
					K_{min} mm	N_{min} mm	K_{min} mm	N_{min} mm	K_{min} mm	N_{min} mm	M Nm	F kN	P_W N/mm ²	P_N N/mm ²	M_S Nm		mm			
25	50	51	41	45	115	49	82	40	68	37	840	67	222	111	17,4	6	M 6	35	0,5	4205-025201-000000
28	55	51	41	45	147	55	100	44	79	38	1 250	89	265	135	17,4	8	M 6	35	0,5	4205-028201-000000
30	55	51	41	45	147	55	100	44	79	38	1 350	89	247	135	17,4	8	M 6	35	0,5	4205-030201-000000
32	60	51	41	45	143	53	102	43	83	38	1 450	89	232	124	17,4	8	M 6	35	0,8	4205-032201-000000
35	60	51	41	45	143	53	102	43	83	38	1 550	89	212	124	17,4	8	M 6	35	0,7	4205-035201-000000
38	65	51	41	45	173	58	120	45	96	39	2 100	110	252	147	17,4	10	M 6	35	1,1	4205-038201-000000
40	65	51	41	45	173	58	120	45	96	39	2 250	110	239	147	17,4	10	M 6	35	1,1	4205-040201-000000
42	75	51	41	45	236	71	159	51	122	42	3 400	160	344	193	42,2	8	M 8	35	1,2	4205-042201-000000
45	75	51	41	45	236	71	159	51	122	42	3 700	160	321	193	42,2	8	M 8	35	1,1	4205-045201-000000
48	80	70	58	62	192	72	136	58	111	52	3 900	160	205	123	42,2	8	M 8	55	1,5	4205-048201-000000
50	80	70	58	62	192	72	136	58	111	52	4 100	160	197	123	42,2	8	M 8	55	1,4	4205-050201-000000
55	85	70	58	62	194	70	141	56	117	50	4 500	160	188	122	42,2	8	M 8	55	1,5	4205-055201-000000
60	90	70	58	62	232	78	163	61	131	53	6 100	200	215	143	42,2	10	M 8	55	1,6	4205-060201-000000
65	95	70	58	62	229	76	165	60	135	52	6 600	200	198	136	42,2	10	M 8	55	1,7	4205-065201-000000
70	110	86	70	76	287	101	199	79	159	69	11 200	320	218	139	83	10	M 10	60	3,0	4205-070201-000000
75	115	86	70	76	283	98	201	78	163	68	12 000	320	203	133	83	10	M 10	60	3,2	4205-075201-000000
80	120	86	70	76	330	109	226	83	179	71	15 500	390	229	153	83	12	M 10	60	3,1	4205-080201-000000
85	125	86	70	76	330	106	231	81	185	69	16 500	390	223	152	83	12	M 10	60	3,5	4205-085201-000000
90	130	86	70	76	327	104	233	80	189	69	17 500	390	211	146	83	12	M 10	60	3,6	4205-090201-000000
95	135	86	70	76	324	102	235	79	193	69	18 500	390	200	141	83	12	M 10	60	3,9	4205-095201-000000
100	145	110	92	98	380	133	262	104	210	91	28 500	570	203	140	144	12	M 12	80	5,9	4205-100201-000000
110	155	110	92	98	373	129	266	102	218	90	31 000	570	185	131	144	12	M 12	80	6,4	4205-110201-000000
120	165	110	92	98	419	138	296	107	239	93	39 500	660	198	144	144	14	M 12	80	6,9	4205-120201-000000
130	180	128	108	114	439	151	312	119	254	105	50 500	780	184	133	229	12	M 14	90	9,7	4205-130201-000000
140	190	128	108	114	495	163	347	126	278	108	63 500	900	200	147	229	14	M 14	90	10,2	4205-140201-000000
150	200	128	108	114	549	174	380	131	301	112	77 500	1 050	213	160	229	16	M 14	90	10,2	4205-150201-000000
160	210	128	108	114	543	169	385	129	309	110	82 500	1 050	202	154	229	16	M 14	90	11,4	4205-160201-000000
170	225	162	136	146	553	192	391	152	318	134	105 000	1 250	176	133	354	14	M 16	110	17,1	4205-170201-000000
180	235	162	136	146	615	205	428	159	343	137	127 000	1 400	190	146	354	16	M 16	110	18,0	4205-180201-000000
190	250	162	136	146	605	199	434	156	354	136	134 500	1 400	180	137	354	16	M 16	110	20,8	4205-190201-000000
200	260	162	136	146	601	196	439	155	363	136	141 500	1 400	171	132	354	16	M 16	110	21,9	4205-200201-000000
220	285	162	136	146	713	215	513	165	416	141	194 500	1 750	198	153	354	20	M 16	110	25,5	4205-220201-000000
240	305	162	136	146	759	222	550	170	447	144	233 000	1 950	199	157	354	22	M 16	110	27,9	4205-240201-000000
260	325	162	136	146	757	214	563	166	465	141	252 500	1 950	188	150	354	22	M 16	110	30,3	4205-260201-000000
280	355	197	165	177	832	249	613	195	504	168	348 000	2 500	182	143	692	18	M 20	130	45,6	4205-280201-000000
300	375	197	165	177	895	260	658	201	540	172	414 500	2 800	188	151	692	20	M 20	130	50,7	4205-300201-000000

Larger elements available on request.

Cone Clamping Elements RLK 402 TC

Premium quality for high centering accuracy
Can be assembled multiple times

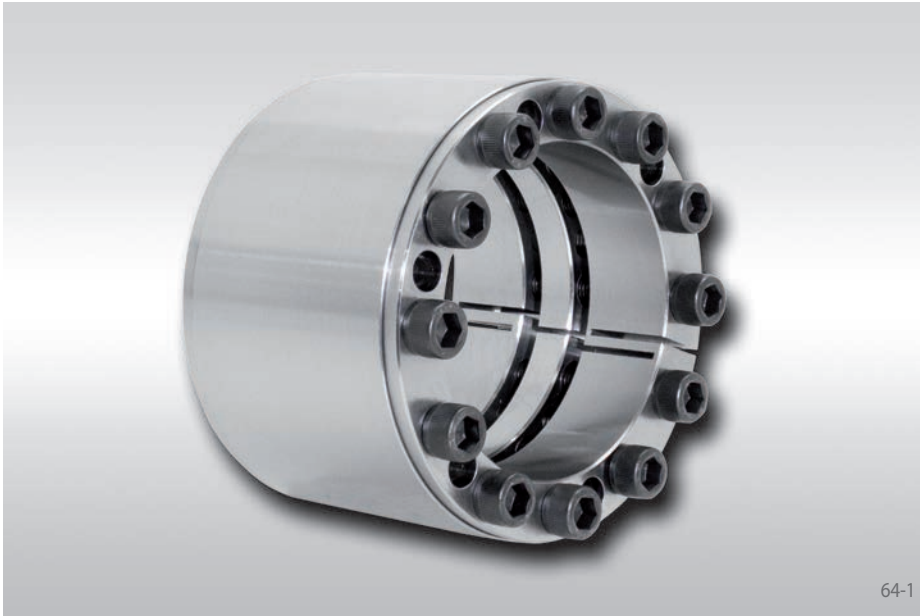

Features

- Centres the shaft to the hub. Double slot for high centering accuracy.
- Can be assembled multiple times
- Highest transmissible torque
- For heavy duty applications
- No axial displacement between hub and shaft during clamping procedure
- Highest machining quality
- Transmissible torque of 11 200 Nm up to 1 701 000 Nm
- For shaft diameters between 70 mm and 600 mm

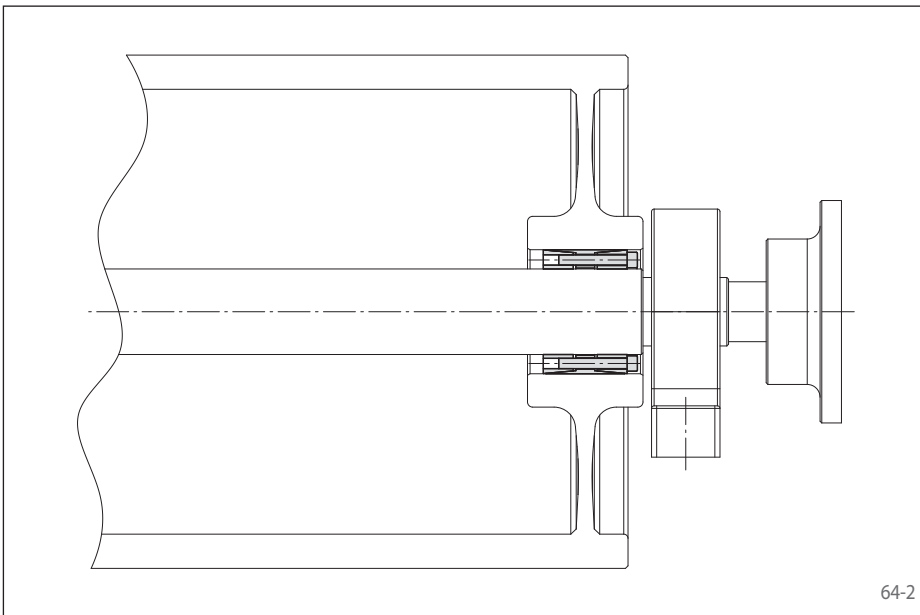

Application example

Backlash free attachment of a belt drum to the drive shaft of a conveyor belt with a Cone Clamping Element RLK 402 TC. The Cone Clamping Element can be used to transmit all acting loads of a driven belt drum. It centres the belt drum on the drive shaft. As no axial shift occurs during the clamping process, the axial position of the belt drum in relation to the drive shaft remains unchanged.

Transmissible torques and axial forces

The transmissible torques or axial forces listed on the following page are subject to the following tolerances, surface characteristics and material requirements. Please contact us in the case of deviations.

Tolerances

- h8 for shaft diameter d
- H8 for hub bore D

Surfaces

Average surface roughness at the contact surfaces between the shaft and the hub bore:
 $R_z = 10 \dots 25 \mu\text{m}$.

Materials

The following apply to the shaft and the hub:

- E-module $\geq 170 \text{ kN/mm}^2$

Installation

Please request our installation and operating instructions for Cone Clamping Elements RLK 402 TC.

Simultaneous transmission of torque and axial force

The transmissible torques M which are shown in the tables apply for axial forces $F = 0 \text{ kN}$ and conversely, the indicated axial forces F apply to torques $M = 0 \text{ Nm}$. If torque and axial force are to be transmitted simultaneously, the transmissible torque and the transmissible axial force are reduced. Please refer to the technical points on pages 74 and 75.

Example for ordering

Cone Clamping Element RLK 402 TC for shaft diameter $d = 100 \text{ mm}$:

- RLK 402 TC, size 100 x 145
Article number 4205-100201-TC0000

Cone Clamping Elements RLK 402 TC

Premium quality for high centering accuracy
Can be assembled multiple times

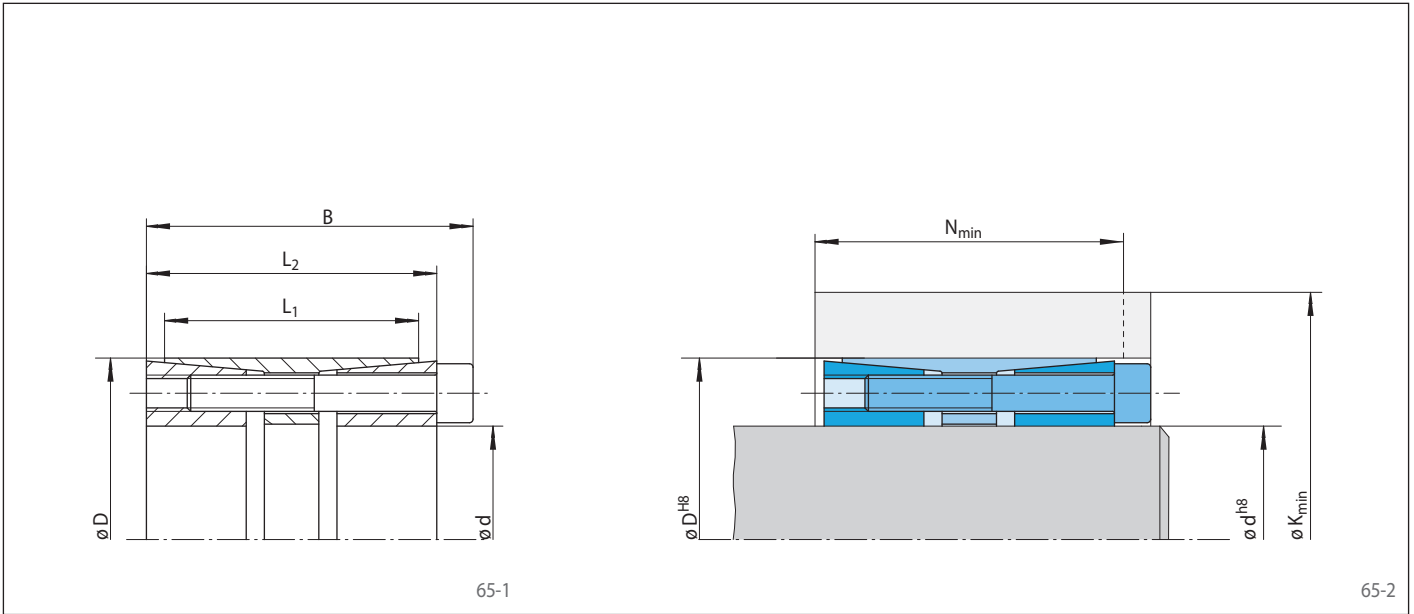

Dimensions						Technical Data														Article number
Size		Yield strength R_e of the hub material [N/mm ²]				Transmissible torque or axial force		Contact pressure at		Clamping screws				Weight	Article number					
d	D	B	L ₁	L ₂	200		320		500		M	F	Shaft	Hub		Tightening torque	Number	Size	Length	kg
mm	mm	mm	mm	mm	K _{min}	N _{min}	K _{min}	N _{min}	K _{min}	N _{min}	Nm	kN	N/mm ²	N/mm ²	M _s		mm	mm		
70	110	88	70	78	287	101	199	79	159	69	11 200	320	218	139	83	10	M 10	60	3,0	4205-070201-TC0000
80	120	88	70	78	305	103	214	80	173	70	14 000	350	210	140	83	11	M 10	60	3,1	4205-080201-TC0000
90	130	88	70	78	327	104	233	80	189	69	17 500	390	211	146	83	12	M 10	60	3,6	4205-090201-TC0000
100	145	112	90	100	351	126	249	100	203	89	26 000	520	186	129	144	11	M 12	80	5,9	4205-100201-TC0000
110	155	112	90	100	373	129	266	102	218	90	31 000	570	185	131	144	12	M 12	80	6,4	4205-110201-TC0000
120	165	112	90	100	419	138	296	107	239	93	39 500	660	198	144	144	14	M 12	80	6,9	4205-120201-TC0000
130	180	130	104	116	439	151	312	119	254	105	50 500	780	184	133	229	12	M 14	90	9,7	4205-130201-TC0000
140	190	130	104	116	495	163	347	126	278	108	63 500	900	200	147	229	14	M 14	90	10,2	4205-140201-TC0000
150	200	130	104	116	518	166	365	128	293	110	72 500	970	200	150	229	15	M 14	90	10,2	4205-150201-TC0000
160	210	130	104	116	543	169	385	129	309	110	82 500	1050	202	154	229	16	M 14	90	11,4	4205-160201-TC0000
170	225	162	134	146	553	192	391	152	318	134	105 000	1 250	176	133	354	14	M 16	110	17,1	4205-170201-TC0000
180	235	162	134	146	581	197	412	155	334	135	119 500	1 350	178	136	354	15	M 16	110	18,0	4205-180201-TC0000
190	250	162	134	146	605	199	434	156	354	136	134 500	1 400	180	137	354	16	M 16	110	20,8	4205-190201-TC0000
200	260	162	134	146	601	196	439	155	363	136	141 500	1 400	171	132	354	16	M 16	110	21,9	4205-200201-TC0000
220	285	162	134	146	656	201	484	158	401	137	175 000	1 600	178	138	354	18	M 16	110	25,5	4205-220201-TC0000
240	305	162	134	146	705	208	523	163	432	140	212 000	1 750	181	143	354	20	M 16	110	27,9	4205-240201-TC0000
260	325	162	134	146	707	202	537	159	451	138	229 500	1 750	171	137	354	20	M 16	110	30,3	4205-260201-TC0000
280	355	197	165	177	832	249	613	195	504	168	348 000	2 500	182	143	692	18	M 20	140	45,6	4205-280201-TC0000
300	375	197	165	177	895	260	658	201	540	172	414 500	2 800	188	151	692	20	M 20	140	50,7	4205-300201-TC0000
320	405	197	165	177	920	259	691	202	574	173	464 000	2 900	185	147	692	21	M 20	140	66,5	4205-320201-TC0000
340	425	197	165	177	948	261	718	204	599	174	516 500	3 000	183	146	692	22	M 20	140	63,8	4205-340201-TC0000
360	455	224	190	202	1016	290	765	228	638	196	649 500	3 600	178	141	945	21	M 22	160	79,8	4205-360201-TC0000
380	475	224	190	202	1048	293	794	230	665	198	718 000	3 800	176	141	945	22	M 22	160	79,8	4205-380201-TC0000
400	495	224	190	202	1111	304	841	237	701	202	824 500	4 100	183	148	945	24	M 22	160	91,0	4205-400201-TC0000
420	515	224	190	202	1110	299	852	235	717	201	866 000	4 100	174	142	945	24	M 22	160	92,1	4205-420201-TC0000
440	535	224	190	202	1112	294	865	233	735	200	907 000	4 100	166	137	945	24	M 22	160	96,6	4205-440201-TC0000
460	555	224	190	202	1115	290	878	231	752	200	948 500	4 100	159	132	945	24	M 22	160	103,2	4205-460201-TC0000
480	575	224	190	202	1230	314	953	245	805	208	1 154 500	4 800	178	148	945	28	M 22	160	108,4	4205-480201-TC0000
500	595	224	190	202	1232	309	965	243	822	207	1 202 500	4 800	171	143	945	28	M 22	160	112,5	4205-500201-TC0000
520	615	224	190	202	1288	318	1 008	248	856	211	1 340 000	5 200	176	149	945	30	M 22	160	117,3	4205-520201-TC0000
540	635	224	190	202	1292	314	1 021	247	873	210	1 391 500	5 200	169	144	945	30	M 22	160	121,1	4205-540201-TC0000
560	655	224	190	202	1346	323	1 063	252	907	213	1 539 500	5 500	174	149	945	32	M 22	160	125,6	4205-560201-TC0000
580	675	224	190	202	1375	325	1 090	254	933	215	1 644 500	5 700	173	149	945	33	M 22	160	134,1	4205-580201-TC0000
600	695	224	190	202	1380	321	1 103	252	950	214	1 701 000	5 700	168	145	945	33	M 22	160	132,9	4205-600201-TC0000

Cone Clamping Elements RLK 404

centres the hub to the shaft
high transmissible torques

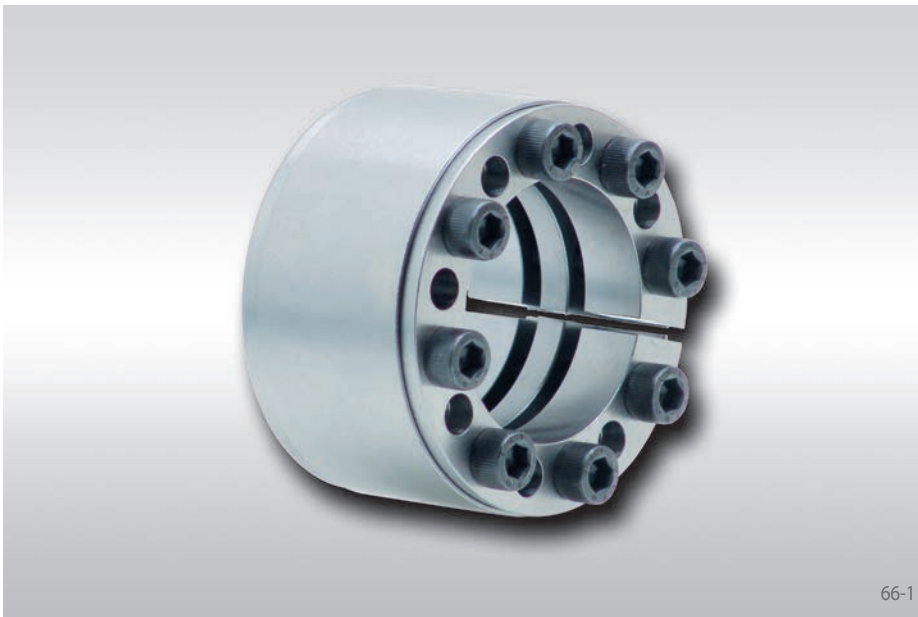

66-1

Features

- Centres the hub to the shaft
- High transmissible torques
- No axial displacement between hub and shaft during clamping procedure
- Transmissible torque of 7000 Nm up to 1206000 Nm
- For shaft diameters between 70 mm and 600 mm

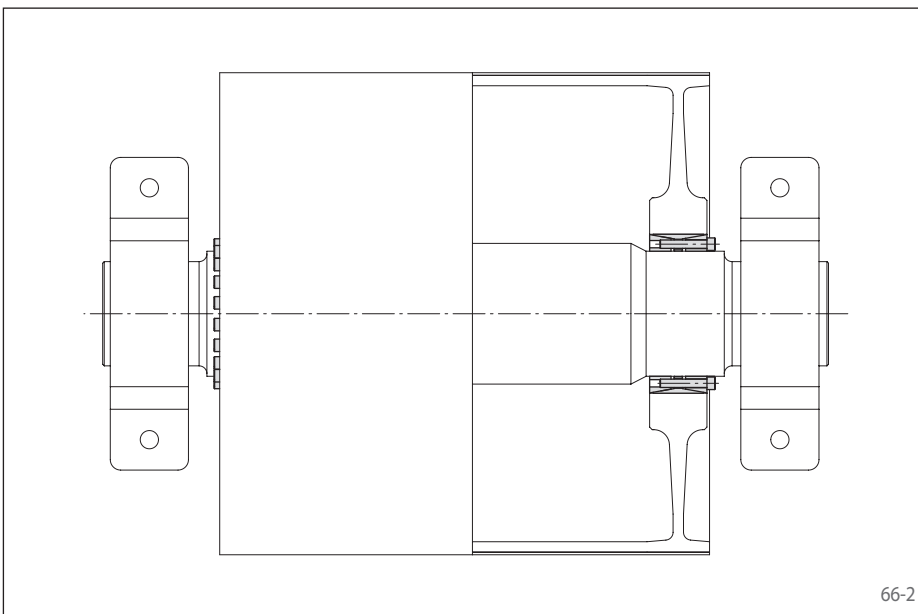

66-2

Application example

Backlash free attachment of a belt drum to the drive shaft of a conveyor belt with an Cone Clamping Element RLK 404. The Cone Clamping Element centres the belt drum on the drive shaft. As no axial shift occurs during the clamping process, the axial position of the belt drum in relation to the drive shaft remains unchanged.

Transmissible torques and axial forces

The transmissible torques or axial forces listed on the following page are subject to the following tolerances, surface characteristics and material requirements. Please contact us in the case of deviations.

Tolerances

- h8 for shaft diameter d
- H8 for hub bore D

Surfaces

Average surface roughness at the contact surfaces between the shaft and the hub bore:
 $R_z = 10 \dots 25 \mu\text{m}$.

Materials

The following apply to the shaft and the hub:

- E-module $\geq 170 \text{ kN/mm}^2$

Installation

Please request our installation and operating instructions for Cone Clamping Elements RLK 404.

Simultaneous transmission of torque and axial force

The transmissible torques M which are shown in the tables apply for axial forces $F = 0 \text{ kN}$ and conversely, the indicated axial forces F apply to torques $M = 0 \text{ Nm}$. If torque and axial force are to be transmitted simultaneously, the transmissible torque and the transmissible axial force are reduced. Please refer to the technical points on pages 74 and 75.

Example for ordering

Cone Clamping Element RLK 404 for shaft diameter $d = 100 \text{ mm}$:

- RLK 404, size 100 x 145
Article number 4205-100401-000000

centres the hub to the shaft
high transmissible torques

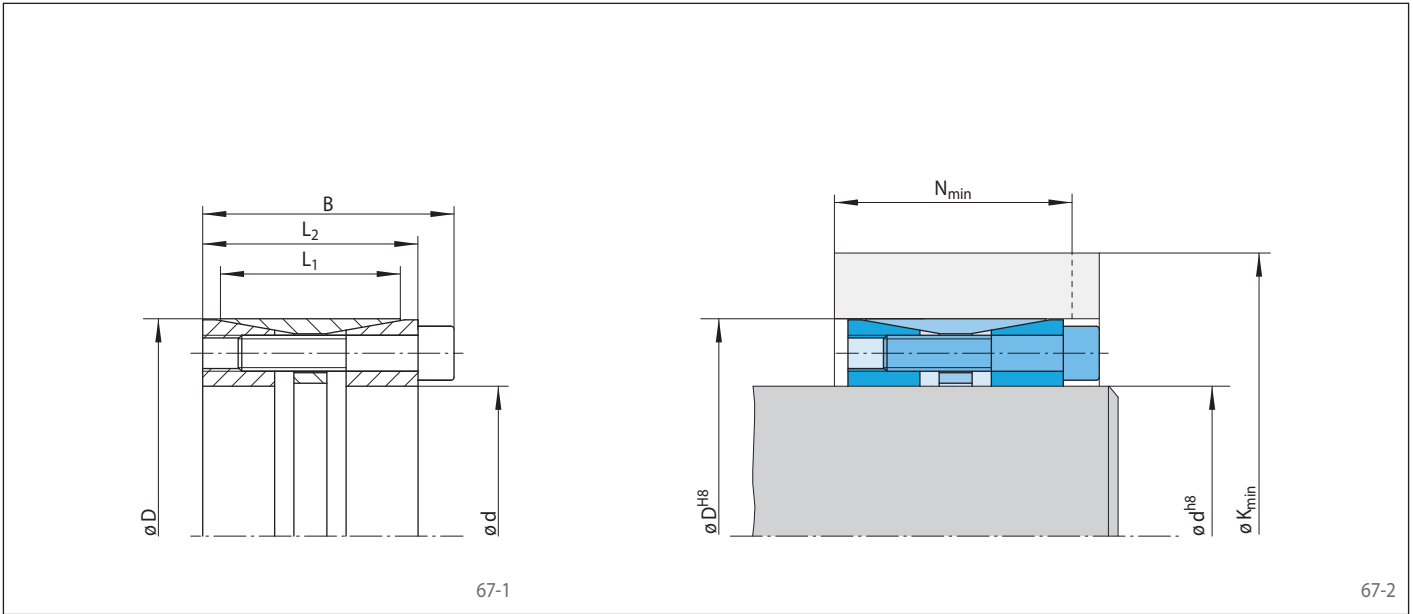

Dimensions												Technical Data										Article number
Size		Yield strength R_e of the hub material [N/mm ²]					Transmissible torque or axial force		Contact pressure at		Clamping screws			Weight								
d mm	D mm	B mm	L ₁ mm	L ₂ mm	K_{min} mm	N_{min} mm	K_{min} mm	N_{min} mm	K_{min} mm	N_{min} mm	M Nm	F kN	Shaft P_W N/mm ²		Hub P_N N/mm ²	Tightening torque M_S Nm	Number	Size	Length mm	kg		
70	110	72	50	62	231	70	177	56	150	49	7000	200	195	124	83	8	M 10	50	2,5	4205-070401-000000		
75	115	72	50	62	232	69	180	56	154	49	7500	200	182	119	83	8	M 10	50	2,5	4205-075401-000000		
80	120	72	50	62	270	77	203	60	169	52	10000	250	213	142	83	10	M 10	50	2,6	4205-080401-000000		
85	125	72	50	62	270	76	206	60	173	51	10600	250	201	137	83	10	M 10	50	2,8	4205-085401-000000		
90	130	72	50	62	287	79	219	62	183	53	12400	280	209	145	83	11	M 10	50	2,9	4205-090401-000000		
95	135	72	50	62	287	77	222	61	187	52	13000	280	198	139	83	11	M 10	50	3,3	4205-095401-000000		
100	145	84	60	72	331	92	249	71	207	61	18500	370	217	150	144	10	M 12	60	4,1	4205-100401-000000		
110	155	84	60	72	330	89	255	70	215	60	20000	370	198	140	144	10	M 12	60	4,5	4205-110401-000000		
120	165	84	60	72	352	92	272	72	230	62	24500	400	199	145	144	11	M 12	60	5,0	4205-120401-000000		
130	180	94	65	82	396	105	303	82	254	70	33500	520	207	149	144	14	M 12	70	6,6	4205-130401-000000		
140	190	94	65	82	415	108	319	84	268	71	38500	550	206	152	144	15	M 12	70	7,1	4205-140401-000000		
150	200	94	65	82	416	105	325	83	277	71	41500	550	192	144	144	15	M 12	70	7,5	4205-150401-000000		
160	210	94	65	82	434	107	341	84	291	72	47000	590	192	146	144	16	M 12	70	7,8	4205-160401-000000		
170	225	107	78	93	490	125	378	97	318	82	64000	760	204	154	229	15	M 14	80	10,8	4205-170401-000000		
180	235	107	78	93	491	122	384	96	327	81	68000	760	192	148	229	15	M 14	80	11,3	4205-180401-000000		
190	250	119	88	105	485	129	385	104	333	91	76500	810	161	123	229	16	M 14	80	14,8	4205-190401-000000		
200	260	119	88	105	523	136	412	108	353	94	90500	910	172	133	229	18	M 14	80	15,7	4205-200401-000000		
220	285	127	96	111	557	144	443	116	382	101	113500	1050	164	127	354	15	M 16	90	19,9	4205-220401-000000		
240	305	127	96	111	668	167	516	129	434	109	165500	1400	201	158	354	20	M 16	90	21,5	4205-240401-000000		
260	325	127	96	111	690	167	539	130	457	109	188000	1450	195	156	354	21	M 16	90	22,8	4205-260401-000000		
280	355	131	96	111	757	171	596	131	507	108	226500	1600	219	173	692	15	M 20	90	29,0	4205-280401-000000		
300	375	131	96	111	789	174	626	133	534	110	258500	1700	218	175	692	16	M 20	90	31,2	4205-300401-000000		
320	405	156	124	136	835	204	657	159	561	135	345000	2150	187	148	692	20	M 20	110	45,9	4205-320401-000000		
340	425	156	124	136	840	200	671	158	578	135	366500	2150	176	141	692	20	M 20	110	48,3	4205-340401-000000		
360	455	177	140	155	931	227	735	178	628	152	482500	2700	183	145	945	20	M 22	130	67,9	4205-360401-000000		
380	475	177	140	155	936	223	748	177	645	151	509000	2700	174	139	945	20	M 22	130	71,4	4205-380401-000000		
400	495	177	140	155	994	233	792	183	680	155	589500	2900	182	147	945	22	M 22	130	74,5	4205-400401-000000		
420	515	177	140	155	1049	242	834	188	715	158	675500	3200	189	154	945	24	M 22	130	77,8	4205-420401-000000		
440	535	177	140	155	1055	238	848	187	732	158	707500	3200	180	148	945	24	M 22	130	81,4	4205-440401-000000		
460	555	177	140	155	1062	235	863	185	750	157	739500	3200	172	143	945	24	M 22	130	84,1	4205-460401-000000		
480	575	177	140	155	1092	237	891	187	775	158	804000	3400	172	144	945	25	M 22	130	88,0	4205-480401-000000		
500	595	177	140	155	1101	235	906	186	793	158	837500	3400	165	139	945	25	M 22	130	91,6	4205-500401-000000		
520	615	177	140	155	1174	248	958	194	835	163	975500	3800	178	150	945	28	M 22	130	94,1	4205-520401-000000		
540	635	177	140	155	1182	245	973	193	852	163	1013000	3800	171	146	945	28	M 22	130	97,5	4205-540401-000000		
560	655	182	140	160	1236	251	1016	196	888	165	1125500	4000	180	154	945	30	M 22	130	100,7	4205-560401-000000		
580	675	182	140	160	1246	249	1031	195	906	164	1166000	4000	174	150	945	30	M 22	130	104,2	4205-580401-000000		
600	695	182	140	160	1256	246	1047	194	924	164	1206000	4000	168	145	945	30	M 22	130	107,6	4205-600401-000000		

Cone Clamping Elements RLK 404 TC

Premium quality for high centering accuracy
Can be assembled multiple times

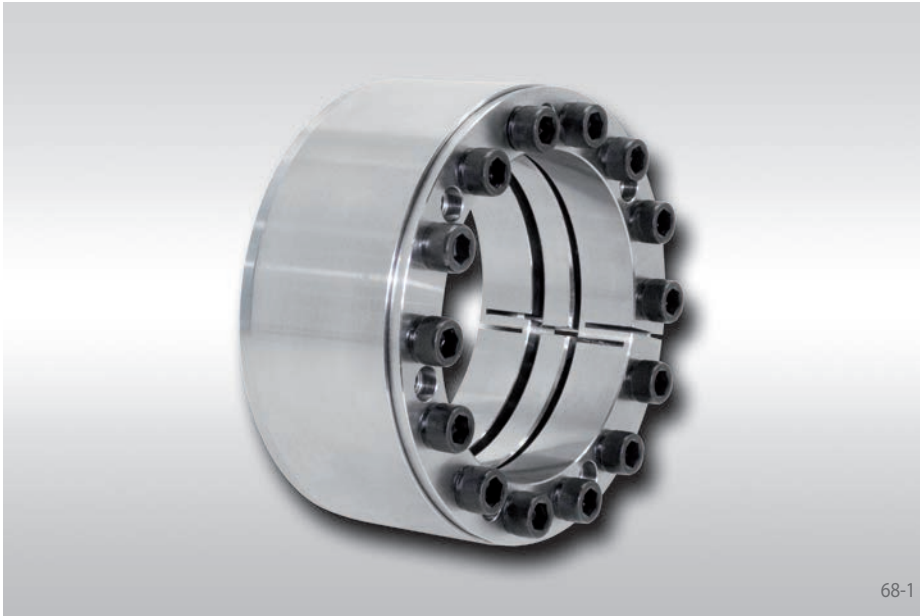

Features

- Centres the shaft to the hub. Double slot for high centering accuracy.
- Can be assembled multiple times
- High transmissible torque
- No axial displacement between hub and shaft during clamping procedure
- Highest machining quality
- Transmissible torque of 7 000 Nm up to 1 206 000 Nm
- For shaft diameters between 70 mm and 600 mm

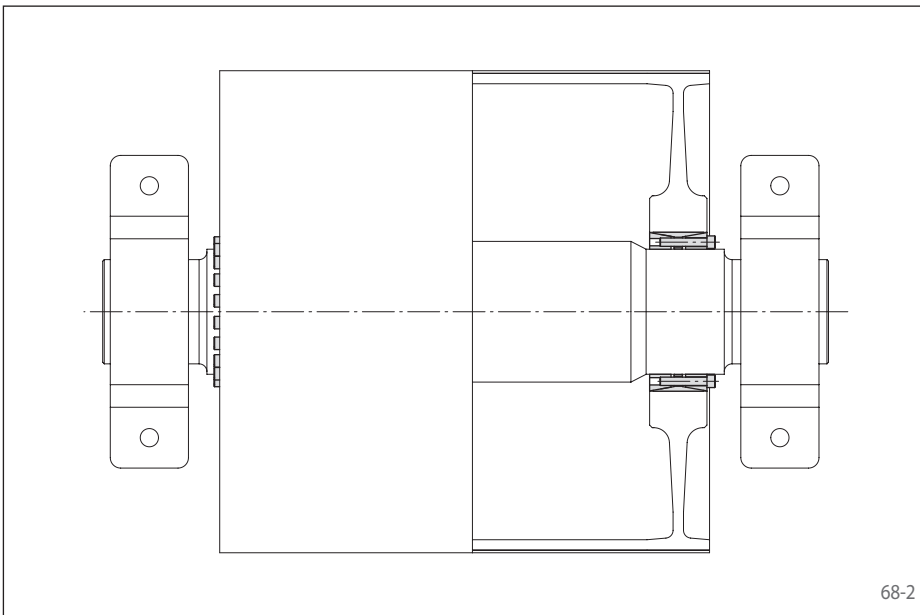

Application example

Backlash free attachment of a belt drum to the drive shaft of a conveyor belt with an Cone Clamping Element RLK 404 TC. The Cone Clamping Element centres the belt drum on the drive shaft. As no axial shift occurs during the clamping process, the axial position of the belt drum in relation to the drive shaft remains unchanged.

Transmissible torques and axial forces

The transmissible torques or axial forces listed on the following page are subject to the following tolerances, surface characteristics and material requirements. Please contact us in the case of deviations.

Tolerances

- h8 for shaft diameter d
- H8 for hub bore D

Surfaces

Average surface roughness at the contact surfaces between the shaft and the hub bore:
 $R_z = 10 \dots 25 \mu\text{m}$.

Materials

The following apply to the shaft and the hub:

- E-module $\geq 170 \text{ kN/mm}^2$

Installation

Please request our installation and operating instructions for Cone Clamping Elements RLK 404 TC.

Simultaneous transmission of torque and axial force

The transmissible torques M which are shown in the tables apply for axial forces $F = 0 \text{ kN}$ and conversely, the indicated axial forces F apply to torques $M = 0 \text{ Nm}$. If torque and axial force are to be transmitted simultaneously, the transmissible torque and the transmissible axial force are reduced. Please refer to the technical points on pages 74 and 75.

Example for ordering

Cone Clamping Element RLK 404 TC for shaft diameter $d = 100 \text{ mm}$:

- RLK 404 TC, size 100 x 145
Article number 4205-100401-TC0000

Premium quality for high centering accuracy
Can be assembled multiple times

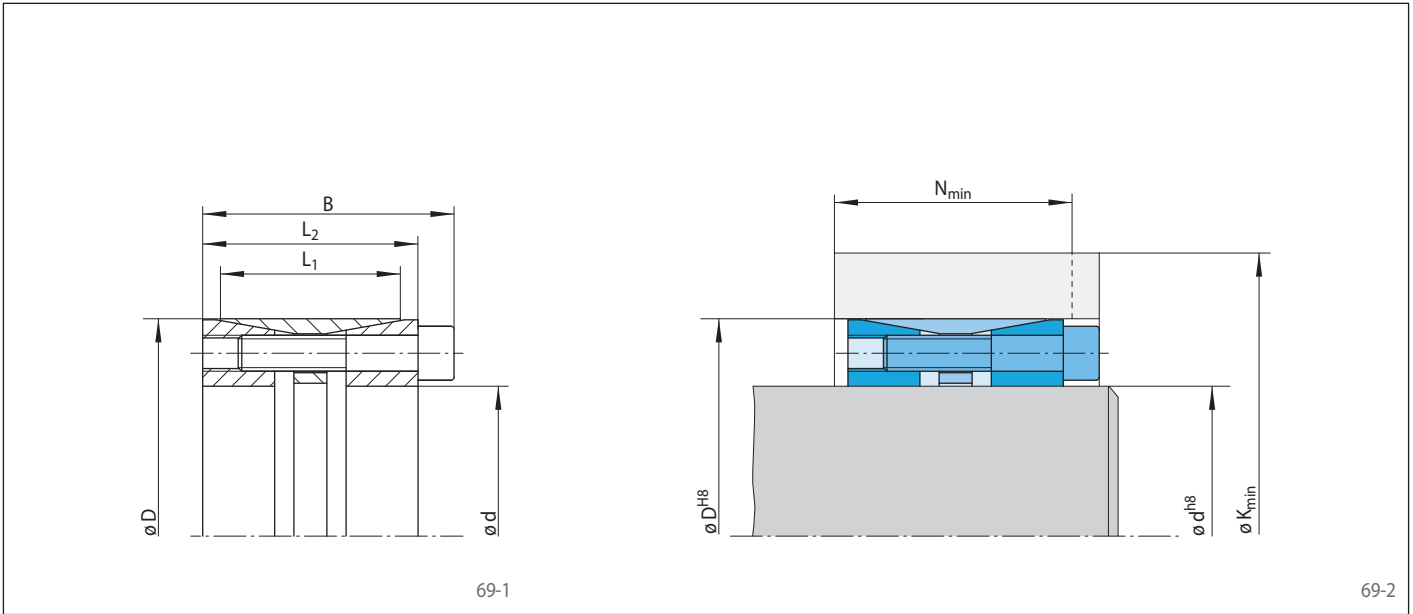

Dimensions												Technical Data										Article number
Size		B mm	L ₁ mm	L ₂ mm	Yield strength R _e of the hub material [N/mm ²]						Transmissible torque or axial force		Contact pressure at		Clamping screws			Weight kg				
d mm	D mm				200	320	500	M	F	Shaft	Hub	Tightening torque	Num- ber	Size	Length							
		K _{min} mm	N _{min} mm	K _{min} mm	N _{min} mm	K _{min} mm	N _{min} mm	M	kN	P _w N/mm ²	P _N N/mm ²	M _S Nm		mm								
70	110	70	50	60	229	70	175	57	149	50	7000	200	190	121	83	8	M 10	50	2,5	4205-070401-TC0000		
80	120	70	50	60	267	77	202	61	168	52	10000	250	208	139	83	10	M 10	50	2,6	4205-080401-TC0000		
90	130	70	50	60	285	79	217	62	182	53	12400	280	203	141	83	11	M 10	50	2,9	4205-090401-TC0000		
100	145	82	60	70	323	93	244	73	203	63	18500	370	204	141	144	10	M 12	60	4,1	4205-100401-TC0000		
110	155	82	60	70	323	90	250	72	212	63	20000	370	185	132	144	10	M 12	60	4,5	4205-110401-TC0000		
120	165	82	60	70	345	93	267	74	227	64	24500	400	187	136	144	11	M 12	60	5,0	4205-120401-TC0000		
130	180	91	65	79	394	106	301	83	253	71	33500	520	203	146	144	14	M 12	65	6,6	4205-130401-TC0000		
140	190	91	65	79	412	108	317	84	267	72	38500	550	202	149	144	15	M 12	65	7,1	4205-140401-TC0000		
150	200	91	65	79	413	106	323	83	275	71	41500	550	188	141	144	15	M 12	65	7,5	4205-150401-TC0000		
160	210	91	65	79	431	108	339	85	289	72	47000	590	188	143	144	16	M 12	65	7,8	4205-160401-TC0000		
170	225	106	78	92	479	126	370	99	313	85	64000	760	189	143	229	15	M 14	75	10,8	4205-170401-TC0000		
180	235	106	78	92	480	124	377	98	322	85	68000	760	179	137	229	15	M 14	75	11,3	4205-180401-TC0000		
190	250	116	88	102	484	129	385	105	332	91	76500	810	160	122	229	16	M 14	80	14,8	4205-190401-TC0000		
200	260	116	88	102	522	136	411	109	352	94	90500	910	171	132	229	18	M 14	80	15,7	4205-200401-TC0000		
220	285	124	96	108	556	145	442	116	381	101	113500	1050	163	126	354	15	M 16	90	19,9	4205-220401-TC0000		
240	305	124	96	108	666	167	514	129	433	109	165500	1400	199	157	354	20	M 16	90	21,5	4205-240401-TC0000		
260	325	124	96	108	688	168	538	130	456	110	188000	1450	193	154	354	21	M 16	90	22,8	4205-260401-TC0000		
280	355	130	96	110	739	173	583	134	497	113	226500	1600	200	158	692	15	M 20	90	29,0	4205-280401-TC0000		
300	375	130	96	110	744	169	597	133	514	112	242500	1600	187	149	692	15	M 20	90	31,2	4205-300401-TC0000		
320	405	156	124	136	827	205	652	161	557	138	345000	2150	181	143	692	20	M 20	110	45,9	4205-320401-TC0000		
340	425	156	124	136	832	201	665	160	574	137	366500	2150	170	136	692	20	M 20	110	48,3	4205-340401-TC0000		
360	455	177	140	155	922	229	728	181	623	154	482500	2700	177	140	945	20	M 22	130	67,9	4205-360401-TC0000		
380	475	177	140	155	927	225	742	179	640	154	509000	2700	168	134	945	20	M 22	130	71,4	4205-380401-TC0000		
400	495	177	140	155	984	234	785	185	675	157	589500	2900	175	142	945	22	M 22	130	74,5	4205-400401-TC0000		
420	515	177	140	155	1039	243	827	190	710	161	675500	3200	182	148	945	24	M 22	130	77,8	4205-420401-TC0000		
440	535	177	140	155	1045	240	841	189	727	160	707500	3200	174	143	945	24	M 22	130	81,4	4205-440401-TC0000		
460	555	177	140	155	1053	237	856	188	745	160	739500	3200	166	138	945	24	M 22	130	84,1	4205-460401-TC0000		
480	575	177	140	155	1083	239	884	190	770	161	804000	3400	166	138	945	25	M 22	130	88,0	4205-480401-TC0000		
500	595	177	140	155	1092	236	899	188	788	161	837500	3400	159	134	945	25	M 22	130	91,6	4205-500401-TC0000		
520	615	177	140	155	1164	249	951	196	829	166	975500	3800	171	145	945	28	M 22	130	94,1	4205-520401-TC0000		
540	635	177	140	155	1173	247	966	195	847	165	1013000	3800	165	140	945	28	M 22	130	97,5	4205-540401-TC0000		
560	655	177	140	155	1222	254	1005	200	880	169	1125500	4000	171	146	945	30	M 22	130	100,7	4205-560401-TC0000		
580	675	177	140	155	1232	251	1021	199	898	168	1166000	4000	165	142	945	30	M 22	130	104,2	4205-580401-TC0000		
600	695	177	140	155	1242	249	1037	198	916	168	1206000	4000	159	137	945	30	M 22	130	107,6	4205-600401-TC0000		

for smallest shaft diameters
excellent concentricity



Features

- For smallest shaft diameters between 3 mm and 16 mm
- Transmissible torque of 10 Nm up to 140 Nm
- Excellent concentricity and transmission of bending moments

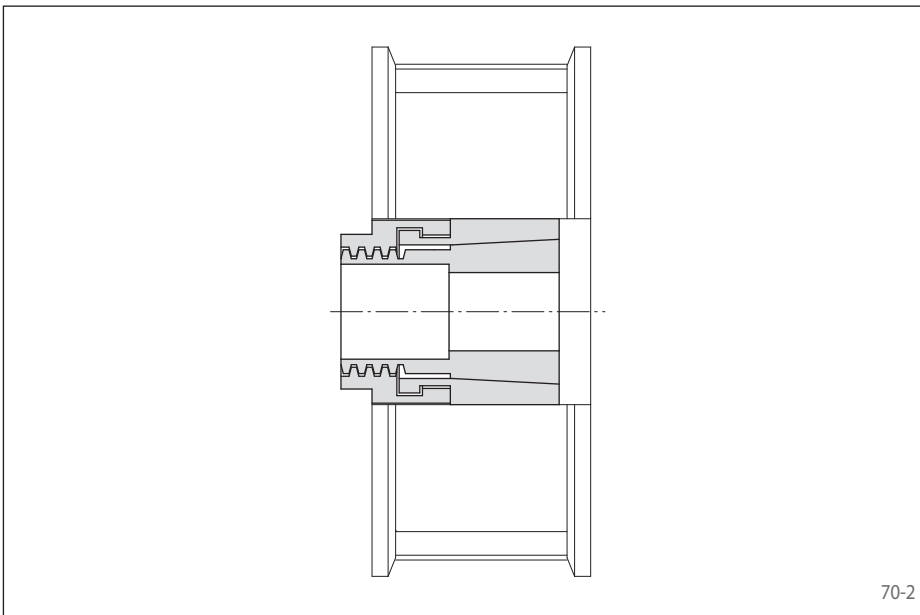

Application example

Cone Clamping Element Trantorque Mini provides a solution for mounting components in tight spaces on very small shafts, such as for a belt pulley.

Transmissible torques and axial forces

The transmissible torques or axial forces listed on the following page are subject to the following tolerances, surface characteristics and material requirements. Please contact us in the case of deviations.

Tolerances

- for shaft diameter $d \pm 0,04$ mm
- for hub bore $D \pm 0,04$ mm

Surfaces

Average surface roughness at the contact surfaces between the shaft and the hub bore:
 $R_z = 10 \dots 25 \mu\text{m}$.

Materials

The following apply to the shaft and the hub:

- E-module $\geq 170 \text{ kN/mm}^2$

During selection of the shaft material the contact pressure P_w of the particular size has to be observed.

Installation

Please request our installation and operating instructions for Cone Clamping Elements Trantorque Mini.

Simultaneous transmission of torque and axial force

The transmissible torques M which are shown in the tables apply for axial forces $F = 0$ kN and conversely, the indicated axial forces F apply to torques $M = 0$ Nm. If torque and axial force are to be transmitted simultaneously, the transmissible torque and the transmissible axial force are reduced. Please refer to the technical points on pages 74 and 75.

Example for ordering

Cone Clamping Element Trantorque Mini for shaft diameter $d = 15$ mm:

- Trantorque Mini, size 15 x 26
Article number 4202-015100-000000

Cone Clamping Elements Trantorque Mini - metric

for smallest shaft diameters
excellent concentricity

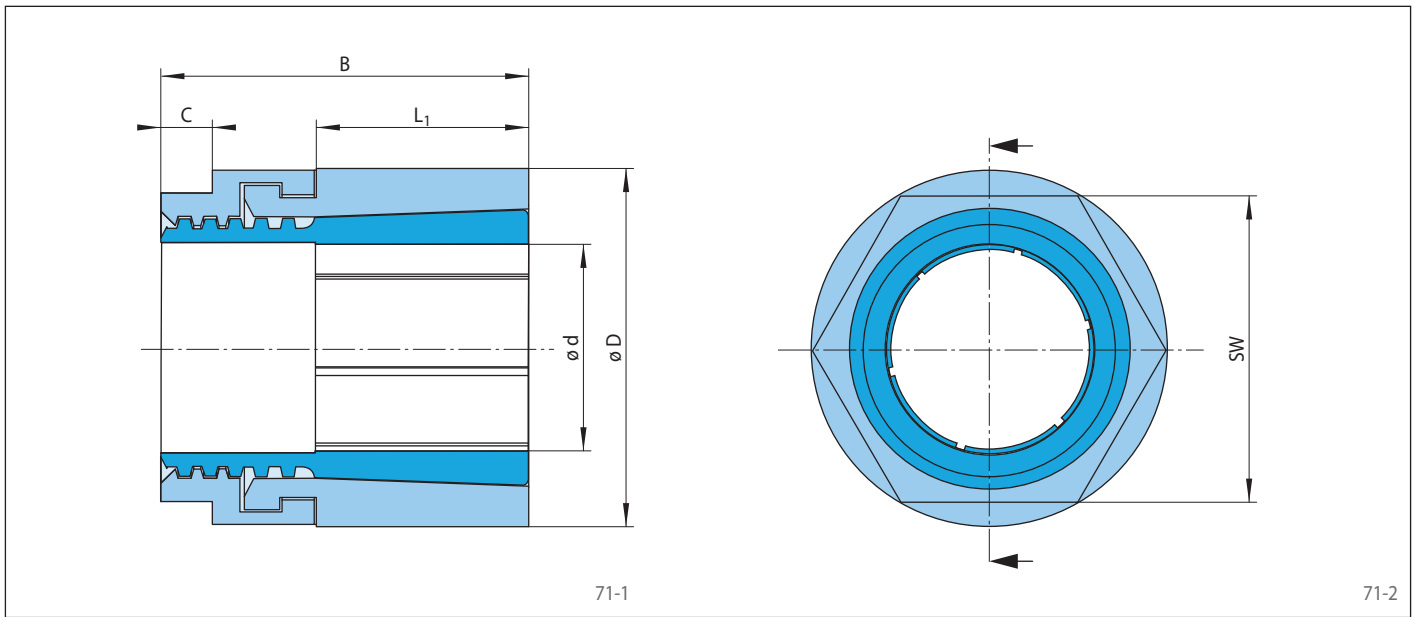

Dimensions						Technical Data						Article number
Size		B mm	C mm	L ₁ mm	SW mm	Max. transmissible torque or axial force		Tightening torque of clamping nut M _S Nm	Contact pressure at		Weight kg	
d mm	D mm					M Nm	F kN		Shaft P _W N/mm ²	Hub P _N N/mm ²		
3	16	19	3	10	13	10	6	14	597	112	0,02	4202-003100-000000
4	16	19	3	10	13	13	6	14	448	112	0,02	4202-004100-000000
5	16	19	3	10	13	16	6	14	358	112	0,02	4202-005100-000000
6	16	19	3	10	13	19	6	14	298	112	0,02	4202-006100-000000
7	20	22	3	11	16	36	10	28	351	123	0,03	4202-007100-000000
8	20	22	3	11	16	41	10	28	307	123	0,03	4202-008100-000000
9	20	22	3	11	16	47	10	28	273	123	0,03	4202-009100-000000
10	23	26	5	13	19	68	14	44	282	123	0,05	4202-010100-000000
11	23	26	5	13	19	75	14	44	257	123	0,05	4202-011100-000000
12	23	26	5	13	19	81	14	44	235	123	0,05	4202-012100-000000
14	26	29	5	16	22	123	18	66	209	113	0,06	4202-014100-000000
15	26	29	5	16	22	132	18	66	195	113	0,06	4202-015100-000000
16	26	29	5	16	22	140	18	66	183	113	0,06	4202-016100-000000

for small shaft diameters
excellent concentricity

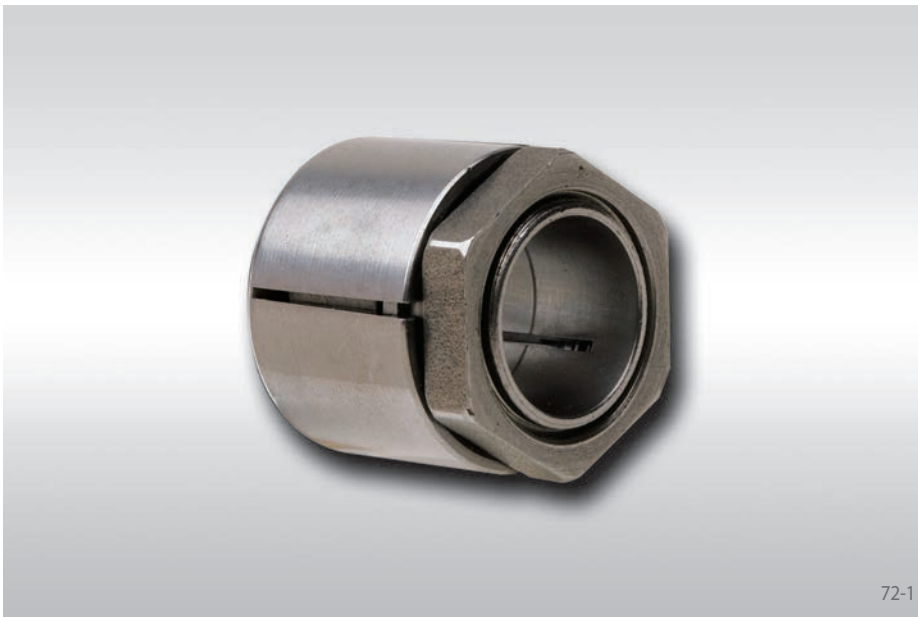

Features

- For small shaft diameters between 17 mm and 35 mm
- Transmissible torque of 211 Nm up to 658 Nm
- Excellent concentricity and transmission of bending moments
- Radial flat height

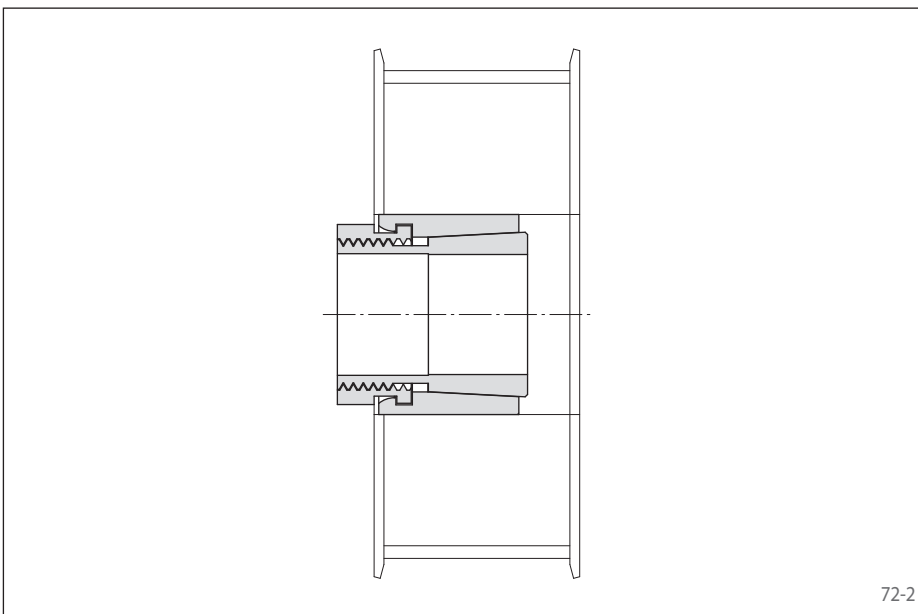

Application example

Backlash free mounting of a belt pulley with a Cone Clamping Element Trantorque OE.

Transmissible torques and axial forces

The transmissible torques or axial forces listed on the following page are subject to the following tolerances, surface characteristics and material requirements. Please contact us in the case of deviations.

Tolerances

- for shaft diameter $d \pm 0,08$ mm
- for hub bore $D \pm 0,08$ mm

Surfaces

Average surface roughness at the contact surfaces between the shaft and the hub bore:
 $R_z = 10 \dots 25 \mu\text{m}$.

Materials

The following apply to the shaft and the hub:

- E-module $\geq 170 \text{ kN/mm}^2$

Installation

Please request our installation and operating instructions for Cone Clamping Elements Trantorque OE.

Simultaneous transmission of torque and axial force

The transmissible torques M which are shown in the tables apply for axial forces $F = 0$ kN and conversely, the indicated axial forces F apply to torques $M = 0$ Nm. If torque and axial force are to be transmitted simultaneously, the transmissible torque and the transmissible axial force are reduced. Please refer to the technical points on pages 74 and 75.

Example for ordering

Cone Clamping Element Trantorque OE for shaft diameter $d = 32$ mm:

- Trantorque OE, size 32 x 50
Article number 4202-032110-000000

for small shaft diameters
excellent concentricity

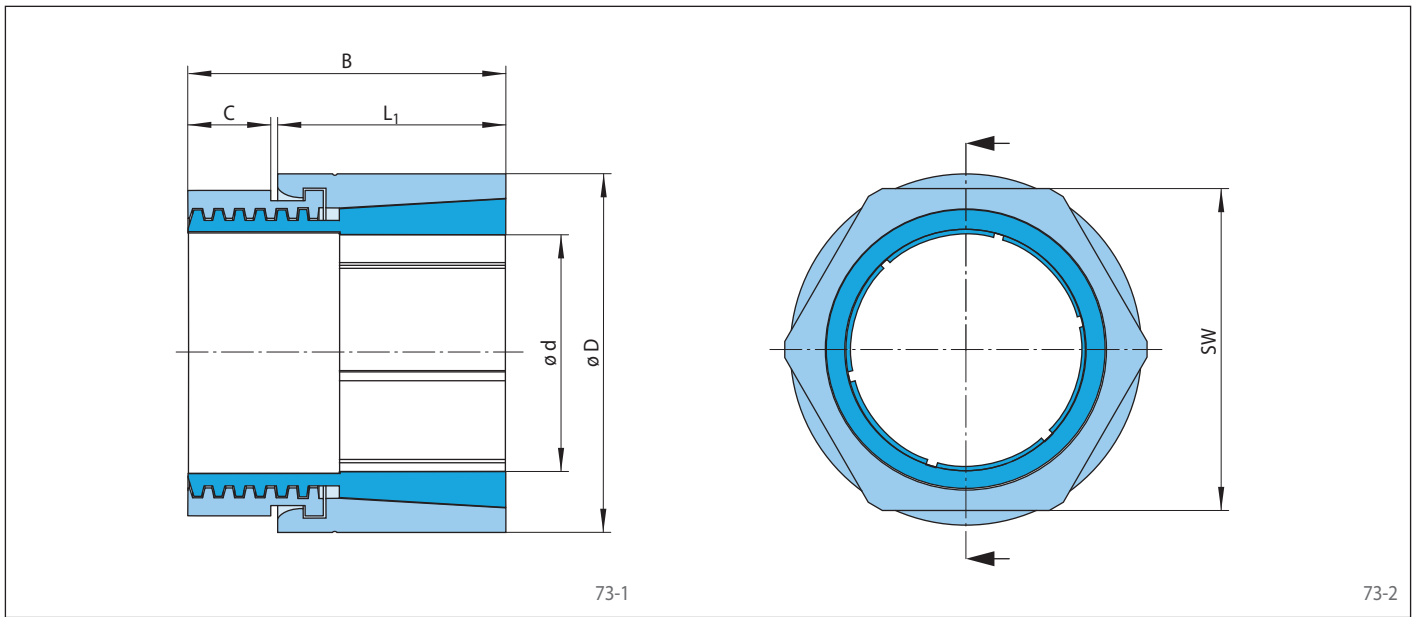

Dimensions						Technical Data						Article number
Size		B mm	C mm	L ₁ mm	SW mm	Max. transmissible torque or axial force		Tightening torque of clamping nut M _S Nm	Contact pressure at		Weight kg	
d mm	D mm					M Nm	F kN		Shaft P _W N/mm ²	Hub P _N N/mm ²		
17	32	29	6	22	30	211	25	110	257	137	0,1	4202-017110-000000
18	32	29	6	22	30	223	25	110	243	137	0,1	4202-018110-000000
19	32	29	6	22	30	236	25	110	230	137	0,1	4202-019110-000000
20	35	32	7	24	32	303	30	150	241	138	0,1	4202-020110-000000
22	35	32	7	24	32	333	30	150	219	138	0,1	4202-022110-000000
24	38	34	7	25	36	405	34	185	204	129	0,2	4202-024110-000000
25	38	34	7	25	36	422	34	185	196	129	0,2	4202-025110-000000
28	45	41	11	29	46	515	37	240	162	101	0,3	4202-028110-000000
30	45	41	11	29	46	551	37	240	151	101	0,3	4202-030110-000000
32	50	43	11	30	50	601	38	265	135	87	0,4	4202-032110-000000
35	50	43	11	30	50	658	38	265	124	87	0,3	4202-035110-000000

Technical Points for Cone Clamping Elements

Clamping screw tightening torque

The tightening torque M_S listed in the tables must be achieved during assembly and must not be exceeded by more than 10%. If the indicated tightening torque M_S is not achieved,

the transmissible torque or axial force, as well as the contact pressures at the shaft and at the hub will be proportionally reduced compared to the values listed in the tables for M or F as well as for

P_W and P_N . When the indicated tightening torque M_S is undercut by more than 30%, please contact us.

Preload force for RLK 300

The preload force is achieved by clamping screws to be provided by the customer, with the tightening torque M_S and the preload force for metric screws E_S to be taken from the table to the right.

The preload forces indicated in the table are corrected for friction value deviations.

Size	Preload Force E_S [kN]			Tightening torque for $\mu_k=0,1$ M_S [Nm]		
	8,8	10,9	12,9	8,8	10,9	12,9
M 4	3,8	5,5	6,7	2,6	3,9	4,5
M 5	6,3	9,4	11,0	5,2	7,6	8,9
M 6	9,1	13,2	15,5	9,0	13,2	15,4
M 8	16,3	24,0	28,2	21,6	31,8	37,2
M 10	26,5	38,5	44,7	43	63	73
M 12	37,4	55,5	64,8	73	108	126
M 14	52,0	76,5	89,1	117	172	201
M 16	70,7	103,9	121,3	180	264	309
M 18	89,6	127,1	149,3	259	369	432
M 20	113,7	162,4	189,7	363	517	605
M 22	141,4	201,5	236,3	495	704	824
M 24	164,6	233,7	273,8	625	890	1041

Number z and size of the clamping screws are to be chosen so that

$$z \cdot E_S = E_1 \text{ or } E_2$$

For RLK 300, the preload force E_1 or E_2 may be increased or decreased as compared to the value indicated in the table. M, F, P_W and P_N change approximately proportionally. When the preload force is exceeded by more than double the value or lower by more than half the value indicated in the table, please contact us.

Design security

On page 8, the RINGSPANN calculation method for determination of the preload forces according to common friction-coefficient fluctuations is explained. As already shown there, the transmissible torques M and axial forces F listed in the tables are calculated based on the minimum preload force F_S , whereas the required hub outer diameters K_{min} are calculated based on the maximum preload force F_S . This assumes that the screw tightening torques M_S assumed in the table are exceeded by 10%.

The calculation for the elements RLK 300, assumes that the preload force of the clamping screws provided by the customer is distributed accordingly.

In the interest of the best design security, the following assumptions were made for the calculation of the Cone Clamping Elements:

For calculating	Assumed preload force	
	for all series except RLK 300	for series RLK 300
M and F	Lower limit value F_S	87% of the table value E_1 or E_2
P_W and P_N	Middle limit value F	table value E_1 or E_2
K_{min}	Upper limit value F_S	128% of the table value E_1 or E_2

Simultaneous transmission of torque and axial force

The transmissible torques M which are shown in the tables apply for axial forces $F = 0$ kN and conversely, the indicated axial forces F apply to torques $M = 0$ Nm. If torque and axial force are to be transmitted simultaneously, the transmissible torque and the transmissible axial force are reduced compared to the values listed in the tables for M and F.

For a given axial force F_A , the reduced torque M_{red} is calculated as:

$$M_{red} = \sqrt{M^2 - (F_A \cdot \frac{d}{2})^2}$$

For a given torque M_A , the reduced axial force F_{red} is calculated as:

$$F_{red} = \frac{2}{d} \sqrt{M^2 - M_A^2}$$

Bending moments

Where there are bending moments in addition to the torque M_A or the axial force F_A , the transmissible torque or transmissible axial force is reduced compared to the values for M or F as listed in the tables. Please contact us.

Hollow shafts

When clamping Cone Clamping Elements on hollow shafts, the tangential stress σ_{tWi} must not exceed the yield strength R_e of the hollow shaft material. For double arrangements of Cone Clamping Elements RLK 300, assume twice the value for L_1 .

$$\sigma_{tWi} = 1,27 \cdot P_W \cdot \frac{2}{1 - C_W^2} \text{ with}$$

$$C_W = \frac{d_{Wi}}{d}$$

Hub Design

For the different Cone Clamping Element series, the tables list the required hub width N_{min} and the required hub outer diameter K_{min} for three exemplary yield strengths R_e of the hub. Thereby, the hub is to be arranged as seen in figure 75-1 for Cone Clamping Elements with a fixed backstop point. For Cone Clamping Elements without a fixed backstop point, the hub is to be arranged according to figure 75-2. For this, we practically assume that the screw heads of the Cone Clamping Element are flush with the hub on one side.

When the hub width in the application N_A is smaller than the required hub width N_{min} and the yield strengths R_e of the hub material is known, the required hub outer diameter K_{min} can be calculated approximately as follows:

$$K_{min} = 1,2 \cdot D \cdot \frac{H - 1,25}{H - 3} \quad \text{with}$$

$$H = \left(\frac{R_e}{1,27 \cdot P_N} \cdot \frac{N_A}{L_T} \right)^2$$

When the hub width N_A is known and the hub outer diameter K_A is known, the hub material yield strength R_e must be higher than the equivalent stress σ_v in the hub.

$$\sigma_v = 1,27 \cdot P_N \cdot \frac{L_T}{N_A} \cdot \frac{\sqrt{3 + C_N^4}}{1 - C_N^2} \quad \text{with}$$

$$C_N = \frac{D}{K_A}$$

The load-bearing hub width N_A in the application must not be smaller than the load-bearing hub width L_1 .

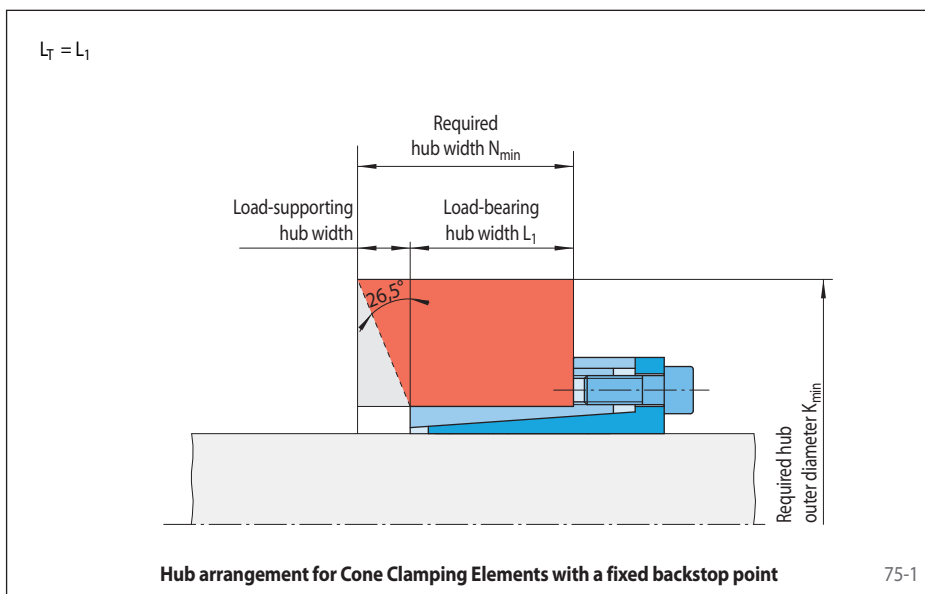

75-1

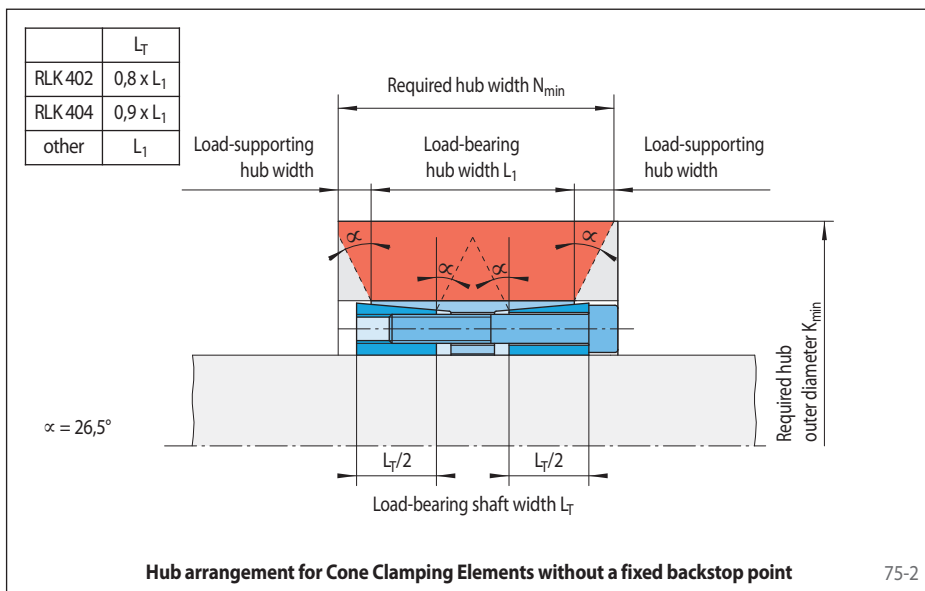

75-2

Formula symbols

d = Shaft diameter [mm]

d_{Wi} = Inner hollow shaft diameter [mm]

D = Hub bore [mm]

E_1, E_2 = Preload force according to table [kN]

E_S = Preload force for metric screws according to table [kN]

F = Transmissible axial force according to table [kN]

F_A = Maximum actual application axial force [kN]

F_{red} = Reduced axial force [kN]

F_S = Preload force [kN]

K_A = Hub outer diameter in the application [mm]

K_{min} = Required hub outer diameter according to table or calculation [mm]

L_1 = Load-bearing axial hub width according to table [mm]

L_T = Load-bearing shaft width [mm]

M = Transmissible torque according to table [Nm]

M_A = Maximum actual application torque [Nm]

M_{red} = Reduced torque [Nm]

M_S = Screw tightening torque [Nm]

N_A = Hub width in the application [mm]

N_{min} = Required hub width according to table [mm]

P_N = Contact pressure at the hub according to table [N/mm²]

P_W = Contact pressure at the shaft according to table [N/mm²]

R_e = Hub material yield strength [N/mm²]

σ_{tWi} = Tangential stress in the hollow shaft [N/mm²]

σ_v = Equivalent stress in the hub [N/mm²]

C_N, C_W and H are reference values without units.

The RINGSPANN Star Disc is a flat conical ring made of special hardened spring steel. The characteristic slot pattern, alternating from the outside to the inside edge, gives the Star Disc its very high elasticity. The outer circumference of the Star Disc is supported in the bore of the hub to be connected. The axial actuating force applied to the inner circumference of the Star Disc causes an elastic change in the conical angle and thus reduces the inner circumference of the Star Disc (see figure 76-1). A particular advantage of this configuration is that the axial actuating force is converted virtually without friction loss into a much higher radial force. This facilitates simple actuating devices, such as clamping with the aid of a central clamping screw or a manually adjusted knurled nut, for example.

Depending upon the torque required, Star Discs are used singly or in multiple arrangements as disc packs, generally consisting of a maximum of 16 discs. This arrangement provides for space-saving, clamping connections.

Clamping connections with Star Discs are easy to release even after frequent clamping. This makes the Star Disc the ideal clamping element, e.g. in adjustment devices.

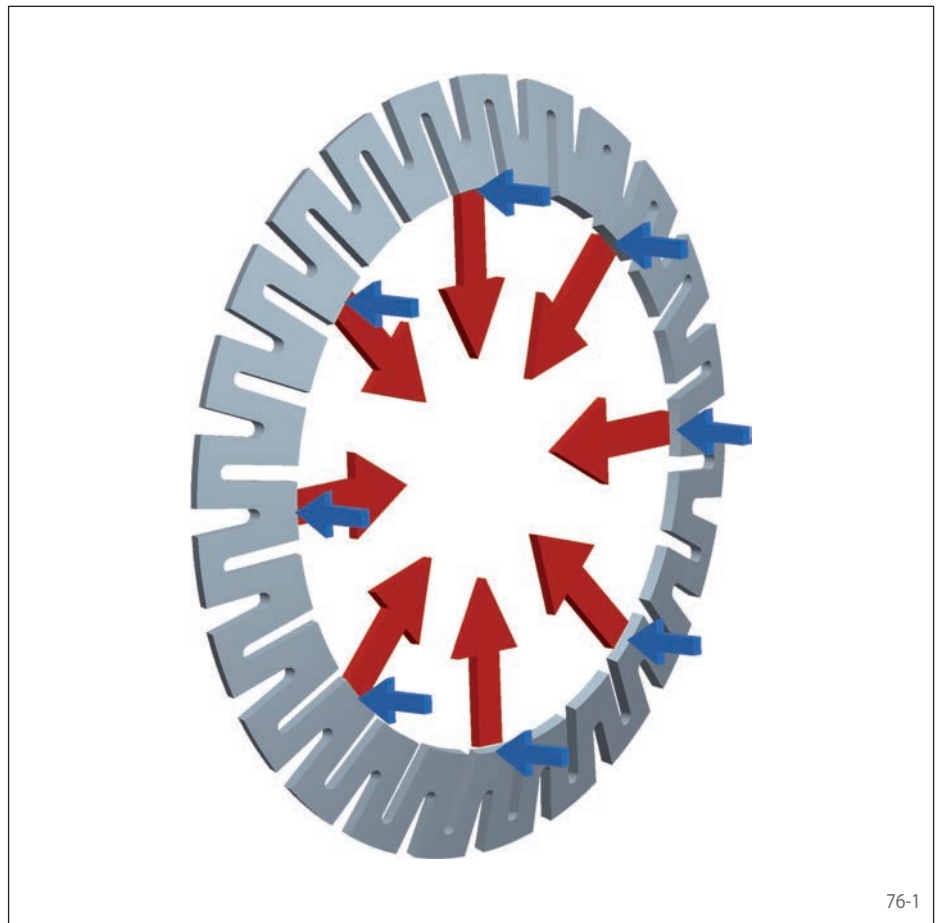

76-1

Features

- For frequent clamping and release
- Short axial width
- Adjustable to the required torque by multiple arrangements in the form of disc packs
- Low actuating force required, thus ideal for manual actuation

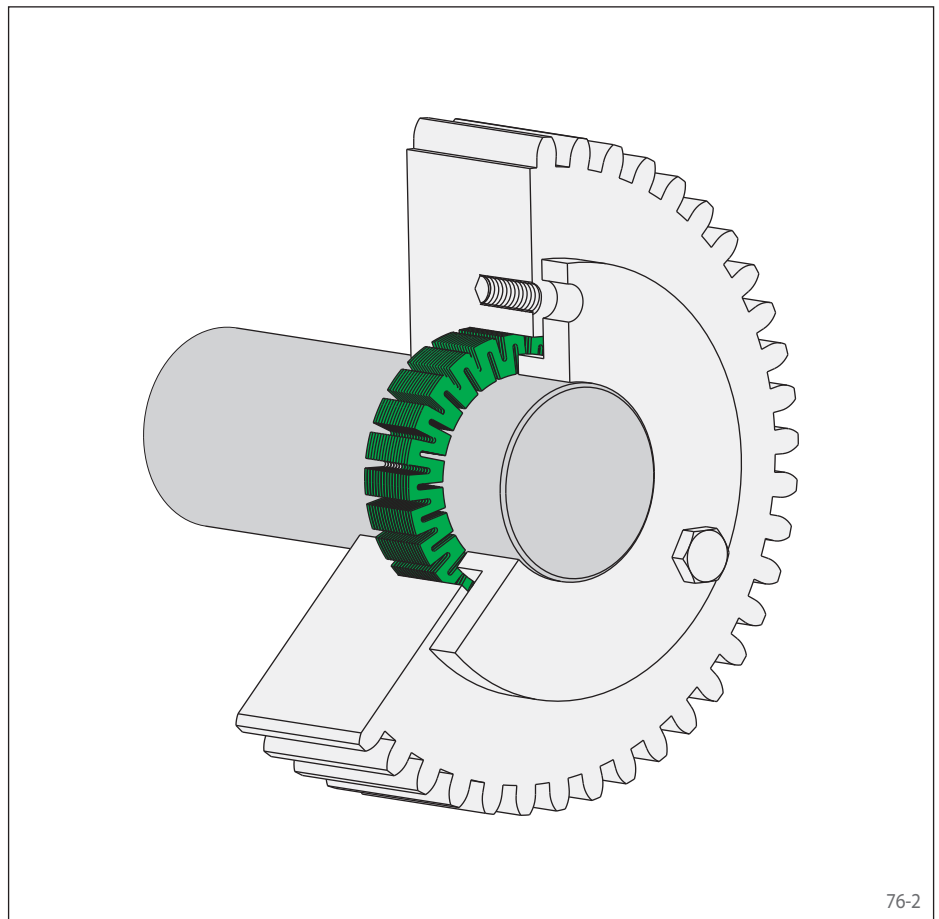

76-2

Clamping connection at the shaft end

Figure 77-1 shows a clamping connection with a disc pack that consists of five Star Discs. The preload force of the clamping nut is transmitted to the disc pack by the opposite shaft shoulder.

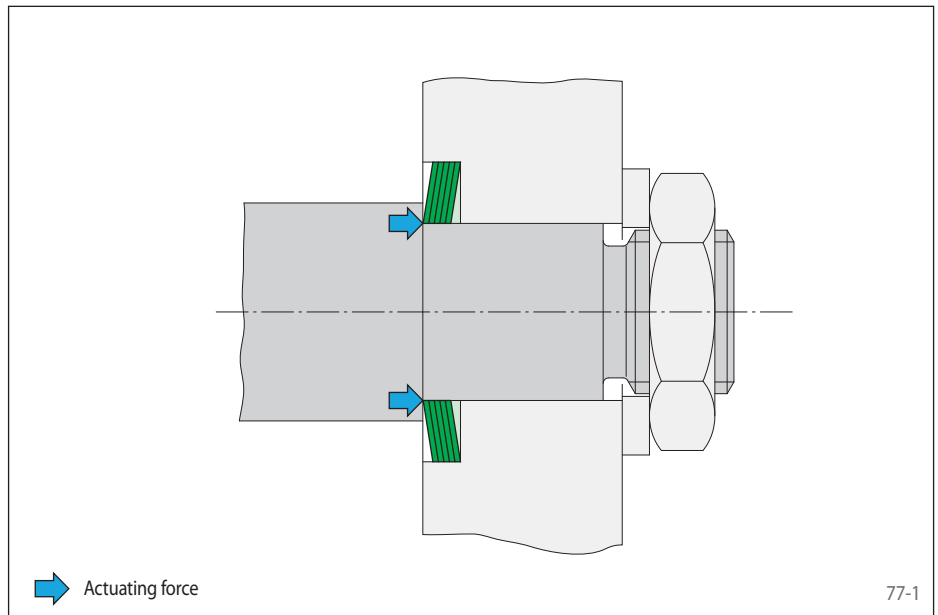

Clamping connection on a continuous shaft

Figure 77-2 shows a clamping connection with a disc pack consisting of ten Star Discs. The preload force of the screws acts on the disc set through a clamping flange.

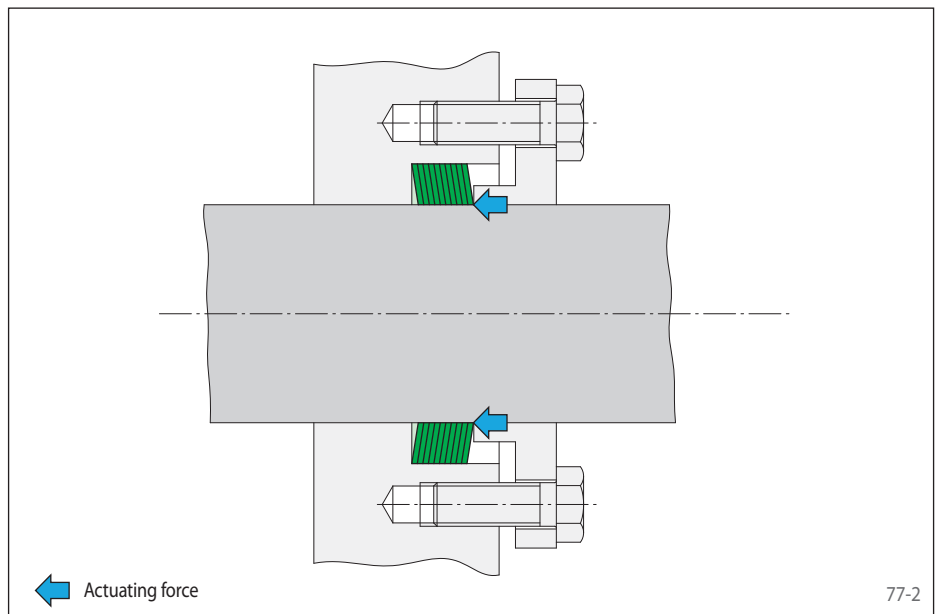

Clamping connection with a threaded ring

Figure 77-3 shows a clamping connection with a disc pack consisting of four Star Discs and a manually adjusted threaded ring. Between the disc pack and the threaded ring, there is a pressure disc. It transmits the axial actuation force to the disc pack inner diameter and thereby prevents the disc pack from turning as well when the threaded ring is tightened.

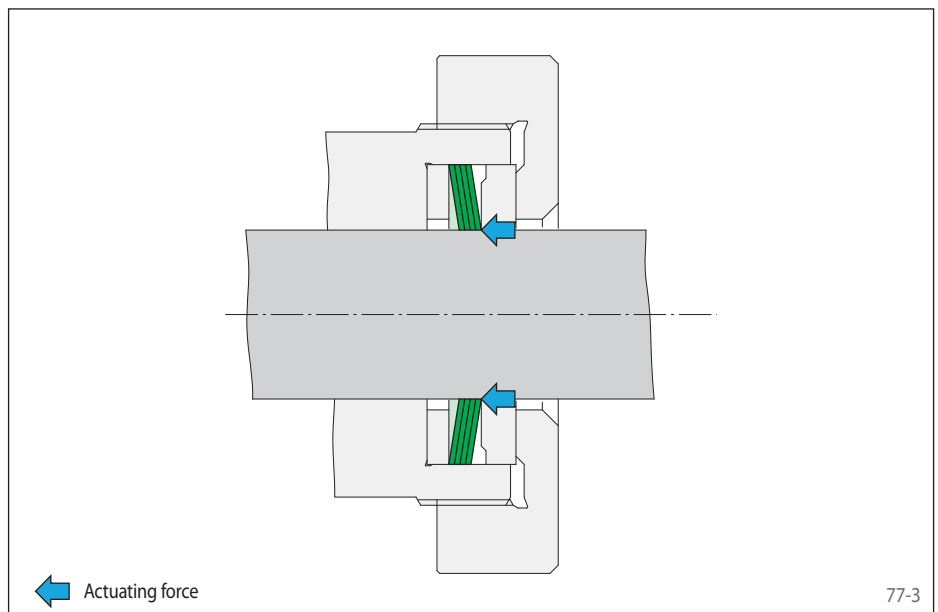

for frequent clamping and loosening
short axial width



78-1

Features

- For frequent clamping and release
- Short axial width
- Adjustable to the required torque by multiple arrangements in the form of disc packs
- Low actuating force required, thus ideal for manual actuation

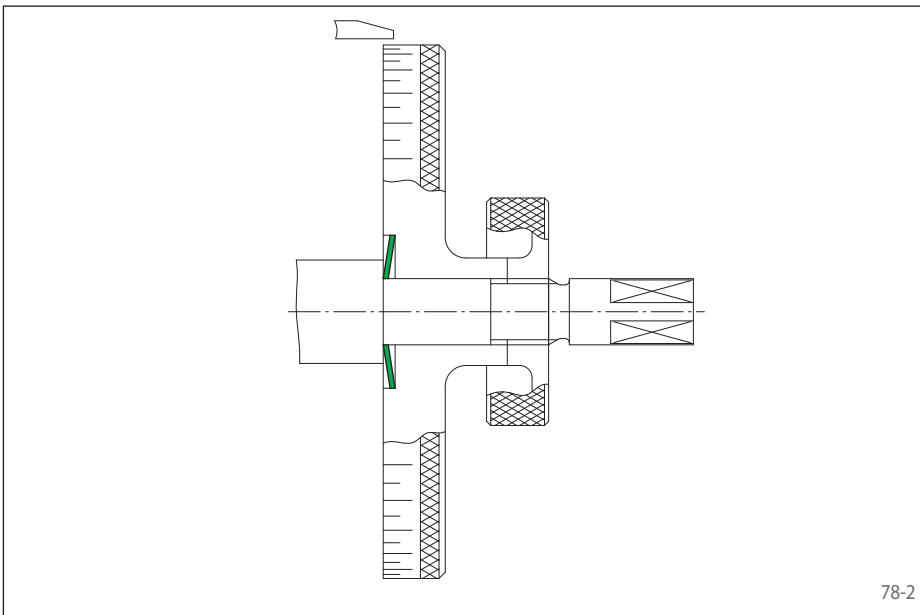

78-2

Application example

Backlash free attachment of a graduated dial in a feed unit with a Star Disc. After release of the right knurled nut, the dial can be adjusted in circumferential direction.

Transmissible torques

The transmissible torques or axial forces listed on the following page are subject to the following information about disc pack, tolerances, surface characteristics and material requirements. Please contact us in the case of deviations.

Disc Pack

The torque M stated in the table applies for one star disc. In case of multiple arrangements of star discs in disc packs of up to 16 star discs, the following applies:

Torque	$M_n = n \cdot M$
Preload force	$E_n = n \cdot E$
Load-bearing axial width	$L_1 \approx n \cdot s$

Tolerances

- h9 for shaft diameter d
- H9 for hub bore D

Surfaces

Average surface roughness at the contact surfaces between the shaft and the hub bore:
 $R_z = 10 \dots 25 \mu\text{m}$.

Materials

The following apply to the shaft and the hub:

- Yield strength $R_e \geq 300 \text{ N/mm}^2$
- E-module $\geq 170 \text{ kN/mm}^2$

Example for ordering

100 Star Discs for shaft diameter $d = 20 \text{ mm}$:

- 100 pcs. A 20 SS 37
Article number 1032-037004-000000

for frequent clamping and loosening
short axial width

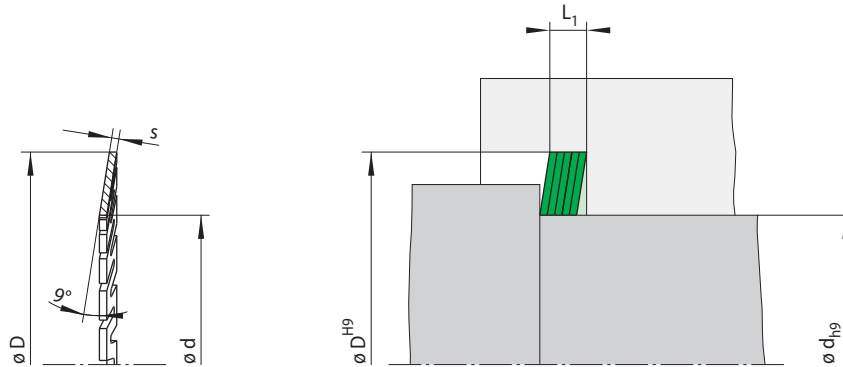

79-1

79-2

Dimensions			Technical Data					Type	Article number
d mm	Size D mm	s mm	Transmissible torque M Nm	Contact pressure at Shaft P_W N/mm ²	Hub P_N N/mm ²	Preload force E N	Weight kg/100 pieces		
4	14	0,50	0,16	100	29	140	0,3	A 4 SS 14	1032-014002-000000
5	14	0,50	0,29	116	41	210	0,3	A 5 SS 14	1032-014003-000000
6	18	0,50	0,34	94	31	180	0,5	A 6 SS 18	1032-018001-000000
8	18	0,50	0,72	113	50	310	0,5	A 8 SS 18	1032-018003-000000
10	22	0,60	1,26	105	48	430	0,9	A 10 SS 22	1032-022002-000000
11	22	0,60	1,53	105	53	500	0,8	A 11 SS 22	1032-022003-000000
12	27	0,65	1,95	104	46	520	1,4	A 12 SS 27	1032-027001-000000
14	27	0,65	2,80	110	57	680	1,3	A 14 SS 27	1032-027003-000000
15	27	0,65	3,30	113	63	770	1,2	A 15 SS 27	1032-027004-000000
16	37	0,90	5,10	111	48	1030	3,7	A 16 SS 37	1032-037001-000000
17	37	0,90	5,90	113	52	1150	3,6	A 17 SS 37	1032-037002-000000
18	37	0,90	6,80	117	57	1270	3,5	A 18 SS 37	1032-037003-000000
20	37	0,90	8,70	121	65	1540	3,2	A 20 SS 37	1032-037004-000000
22	42	0,90	9,90	114	60	1490	4,3	A 22 SS 42	1032-042001-000000
24	42	0,90	12,2	118	67	1760	4,0	A 24 SS 42	1032-042002-000000
25	42	0,90	13,5	120	71	1900	3,8	A 25 SS 42	1032-042003-000000
28	52	1,15	21,0	116	63	2550	8,2	A 28 SS 52	1032-052001-000000
30	52	1,15	25,0	121	70	2900	7,7	A 30 SS 52	1032-052002-000000
35	52	1,15	33,5	119	80	3750	6,3	A 35 SS 52	1032-052004-000000
38	62	1,15	40,5	122	75	3600	10,2	A 38 SS 62	1032-062001-000000
40	62	1,15	45,5	124	80	4000	9,5	A 40 SS 62	1032-062002-000000
42	62	1,15	51,0	126	85	4450	8,8	A 42 SS 62	1032-062003-000000
45	62	1,15	60,0	129	94	5200	7,7	A 45 SS 62	1032-062004-000000
48	70	1,15	68,0	128	88	5000	11,0	A 48 SS 70	1032-070001-000000
50	70	1,15	75,0	130	93	5500	10,2	A 50 SS 70	1032-070002-000000
55	70	1,15	93,0	134	105	7000	8,0	A 55 SS 70	1032-070003-000000
60	80	1,15	112	135	101	6800	11,9	A 080 060 IV	1032-080001-000000
65	90	1,15	131	135	97	6700	16,5	A 090 065 IV	1032-090001-000000
70	90	1,15	154	137	106	8000	13,6	A 090 070 IV	1032-090002-000000
75	100	1,15	176	136	102	7800	18,6	A 100 075 IV	1032-100001-000000
80	100	1,15	205	139	111	9300	15,3	A 100 080 IV	1032-100002-000000
85	110	1,15	230	138	107	9000	20,7	A 110 085 IV	1032-110001-000000
100	120	1,15	325	141	118	11900	18,7	A 120 100 IV	1032-120001-000000

Technical Points for Star Discs

Design points

The outer diameter D of the Star Disc is supported in the bore of the hub to be connected. The Star Disc seats with the concave face of the cone against the fixed backstop point of the hub. The axial actuation force must be applied opposite at the front side of the inner diameter d .

The passages from shaft diameter d and supporting diameter D to the respective plane surfaces must be sharp-edged, without corner arc or undercut.

The shaft must be centred according to the requirements.

If a torque M_A and an axial force F_A are to be transmitted at the same time, please contact us.

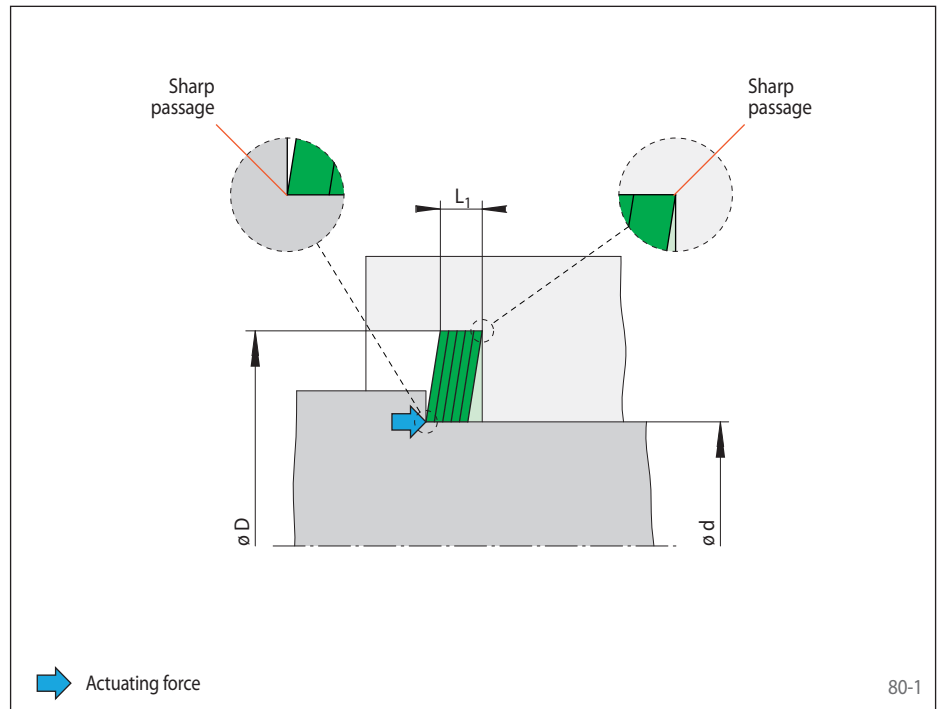

Frequent clamping and release

Clamping connections with Star Discs can be easily released repeatedly. They can be clamped and released up to 5 000 times. Star Discs from

size A 080 060 IV are durable and not subject to this limitation.

For loosening the clamping connection, displace the hub against the shaft

Preload force

The preload force is achieved by clamping screws to be provided by the customer, with the tightening torque M_S and the preload force for metric screws E_S to be taken from the table to the right.

The preload forces indicated in the table are corrected for friction value deviations.

Size	Preload force E_S [kN]			Tightening torque for $\mu_k=0,1$ M_S [Nm]		
	8,8	10,9	12,9	8,8	10,9	12,9
M 4	3,8	5,5	6,7	2,6	3,9	4,5
M 5	6,3	9,4	11,0	5,2	7,6	8,9
M 6	9,1	13,2	15,5	9,0	13,2	15,4
M 8	16,3	24,0	28,2	21,6	31,8	37,2

Number z and size of the clamping screws are to be chosen so that

$$E \text{ or } E_n = z \cdot E_S \cdot 1000$$

If the preload force E or E_n is exceeded, the Star Disc will be overstressed or the permissible contact pressure will be exceeded.

Disc Pack

Star Discs are used separately or combined to disc packs according to the required torque. For multiple arrangements in a disc pack of $n = 16$ Star Discs, the following applies:

Torque $M_n = n \cdot M$

Preload force $E_n = n \cdot E$

Load-bearing axial width $L_1 \approx n \cdot s$

For disc packs with more than 16 Star Discs, any Star Discs exceeding 16 will only transmit approx. 50% of the torque M . The maximum number of Star Discs in a pack is limited to 25.

Hollow Shafts

When clamping Star Discs on hollow shafts, the tangential stress σ_{tWi} must not exceed the yield strength R_e of the hub material.

$$\sigma_{tWi} = 1,27 \cdot P_W \cdot \frac{2}{1 - C_W^2} \text{ with}$$

$$C_W = \frac{d_{Wi}}{d}$$

Hub Design

The contact pressure P_W leads to radial stress in the shaft that is usually not critical for solid steel shafts.

There is always a tangential stress σ_t in the hub, and for thin-walled hubs it may be a multiple of the initiated pressure P_N . The amount of the applicable tangential stress depends on the load-bearing hub width N_{min} , the hub outer diameter K_{min} and the pressure P_N . For the load-bearing hub width N_{min} is taken into account, that the hub pressure P_N is carried by the load-bearing width L_1 , and in an angle of ca. $26,5^\circ$ beyond it (see figure 81-1).

When the load-bearing hub width N_A and the yield strength R_e of the hub material are given, the required hub outer diameter K_{min} can be calculated approximately as follows:

$$K_{min} = 1,2 \cdot D \cdot \frac{H - 1,25}{H - 3} \text{ with}$$

$$H = \left(\frac{R_e}{1,27 \cdot P_N} \cdot \frac{N_A}{L_1} \right)^2$$

When the hub width N_A and the hub outer diameter K_A are given, the hub material yield strength R_e must be higher than the equivalent stress σ_v in the hub.

$$\sigma_v = 1,27 \cdot P_N \cdot \frac{L_1}{N_A} \cdot \sqrt{\frac{3 + C_N^4}{1 - C_N^2}} \text{ with}$$

$$C_N = \frac{D}{K_A}$$

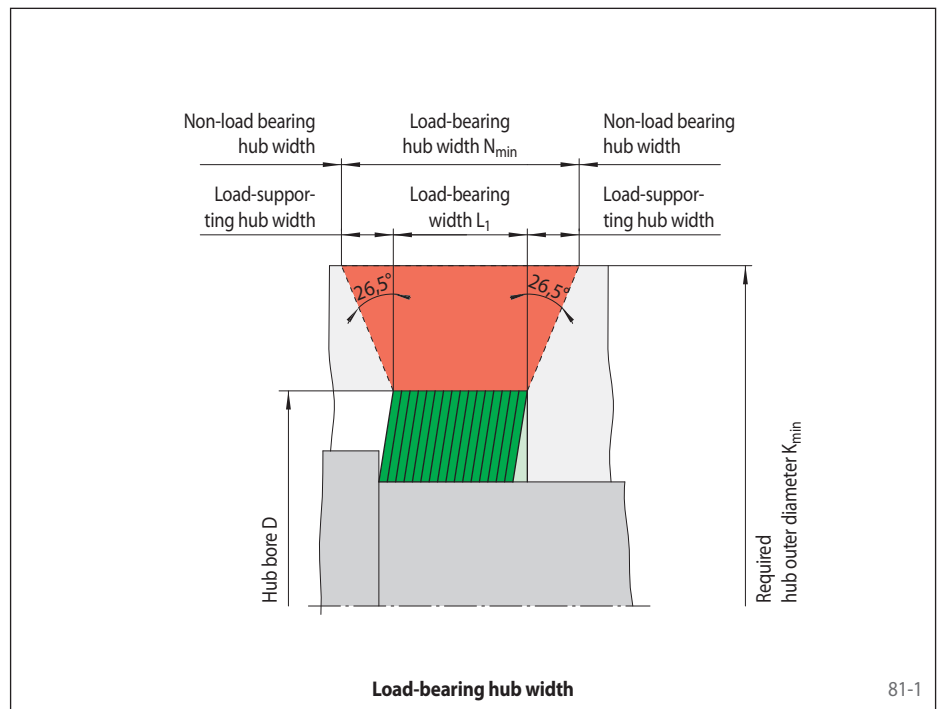

Formula symbols

d = Shaft diameter [mm]	L_1 = Load-bearing axial width [mm]	P_W = Contact pressure at the shaft according to table [N/mm ²]
d_{Wi} = Inner hollow shaft diameter [mm]	M = Transmissible torque according to table [Nm]	R_e = Hub material yield strength [N/mm ²]
D = Hub bore [mm]	M_A = Maximum actual application torque [Nm]	s = Axial width according to table [mm]
E = Preload force according to table [N]	M_n = Max. transmissible torque of the Star Disc pack [Nm]	z = Number of clamping screws
E_n = Preload force disc pack [N]	M_5 = Screw tightening torque [Nm]	σ_t = Tangential stress in the hub [N/mm ²]
E_S = Preload force for metric screws according to table [kN]	n = Number of star discs in the pack	σ_{tWi} = Tangential stress in the hollow shaft [N/mm ²]
F_A = Maximum actual application axial force [kN]	N_A = Load-bearing hub width in the application [mm]	σ_v = Equivalent stress in the hub [N/mm ²]
K_A = Hub outer diameter in the application [mm]	P_N = Contact pressure at the hub according to table [N/mm ²]	C_N, C_W and H are reference values without units.
K_{min} = Required hub outer diameter according to table or calculation [mm]		

The advantage of torque motors can be fully exploited only if the torque motor is connected to the machine shaft in an appropriate manner for the application in question. RINGSPANN has developed Clamping Systems that meet the specific requirements of both torque motors and machine shafts which are often configured as thin-walled hollow shafts.

Both complete torque motors and integrated torque motors can be connected by friction to machine shafts with RINGSPANN torque motor clamping systems. In addition to secure, backlash free torque transmission, these systems also ensure precise centring of the torque motor on the machine shaft.

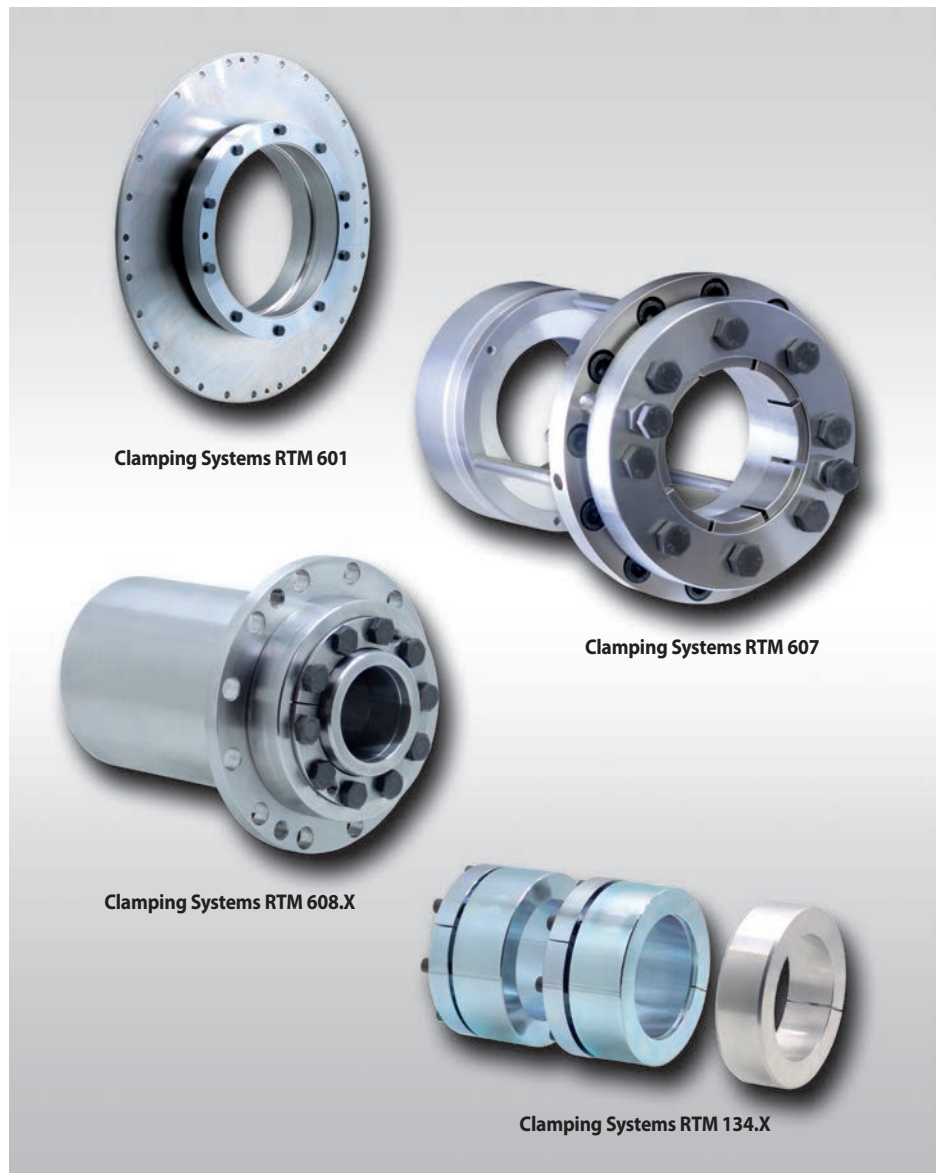

Torque motors

Torque motors are rotation angle controlled, permanent magnet excited synchronous servomotors with large numbers of magnetic pole pairs which produce correspondingly high torques in the lower rpm range (0 - approximately 250 rpm, depending on the number of pole pairs). Thanks to modern high performance electronics, torque motors, as direct drive motors, are capable of meeting such system requirements as high repetition and control accuracy, low energy consumption, low noise levels, high dynamics, ease of maintenance and reduced space requirements.

Torque motors are designed as „integrated torque motors“ (Fig. 82-1) with rotors and stators or as self-enclosed „complete torque motors“ with bearings“ (Fig. 82-2).

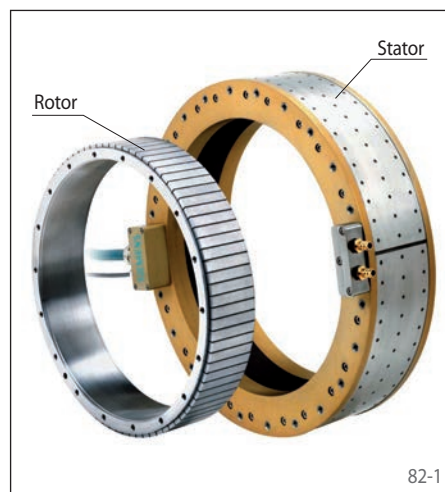

Source: Siemens AG

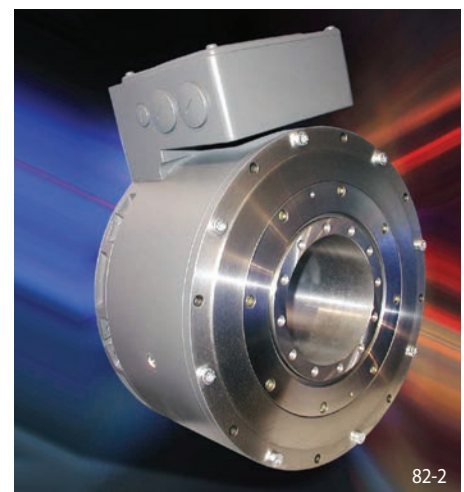

Source: Siemens AG

Clamping Systems RTM 601

for integrated torque motors
for mounting and centring rotors on shafts or hollow shafts

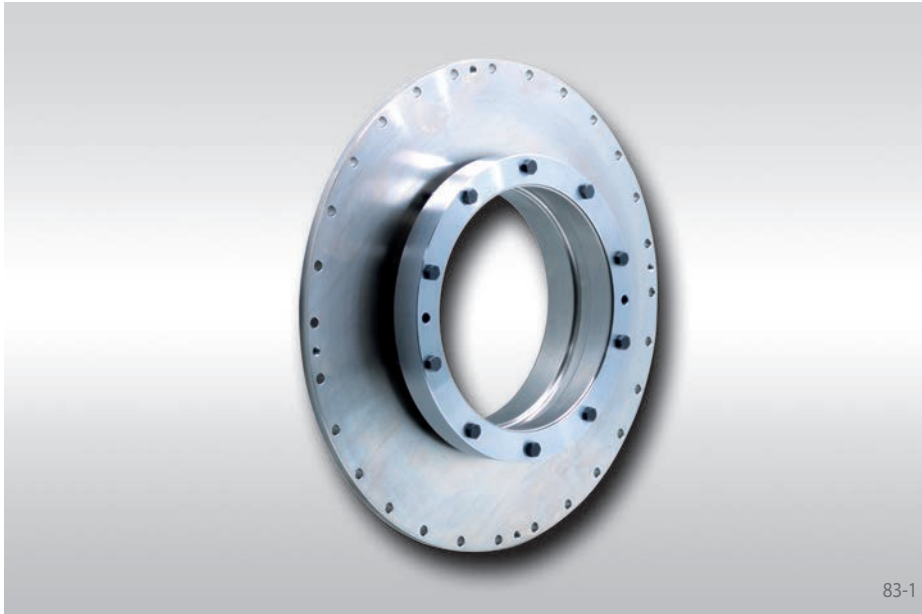

Features

- Provides a mechanical connection and centring between rotor and machine shaft
- Backlash free, torsion-proof transmission of torque generated by the torque motor
- High true run accuracy between rotor and a stator mounted on the machine
- Low contact pressures exerted on machine shafts or hollow shafts
- Taper Collet chemically nickel-coated to prevent fretting corrosion
- Easily removable clamping element, even after long periods of operation

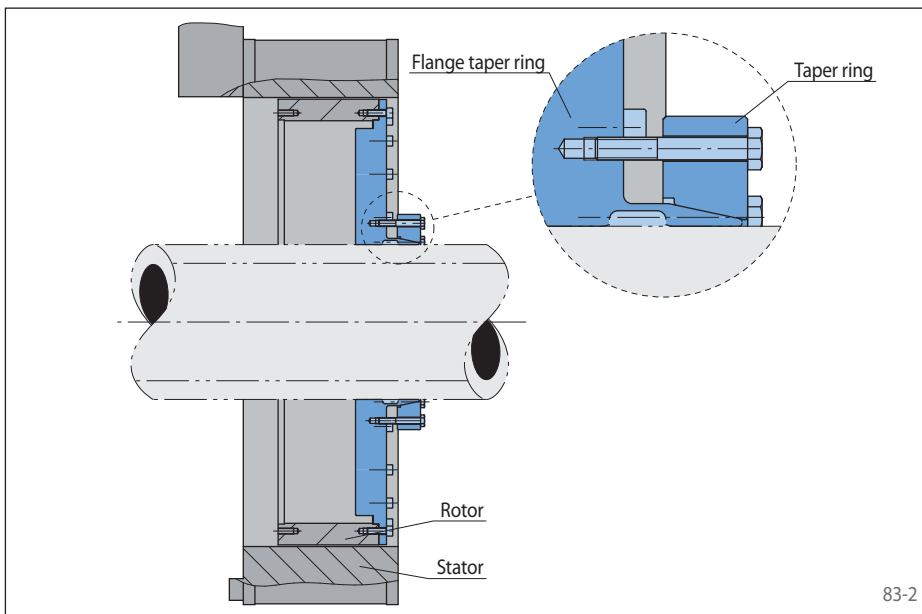

Configuration

The Clamping System RTM 601 consists of a flange taper ring and taper ring. The taper ring clamps the flange taper ring to the machine shaft with the aid of clamping screws in such a way that the torque generated between the stator and rotor of the integrated torque motor is transmitted to the machine shaft via a frictional, backlash free connection.

If you have an application for which the Clamping System RTM 601 is suited, please submit your enquiry, including the designation of the torque motor to be used as well as the shaft dimensions.

Clamping Systems RTM 607

for SIEMENS complete torque motors 1FW3

for mounting and centring complete torque motors on shafts or hollow shafts

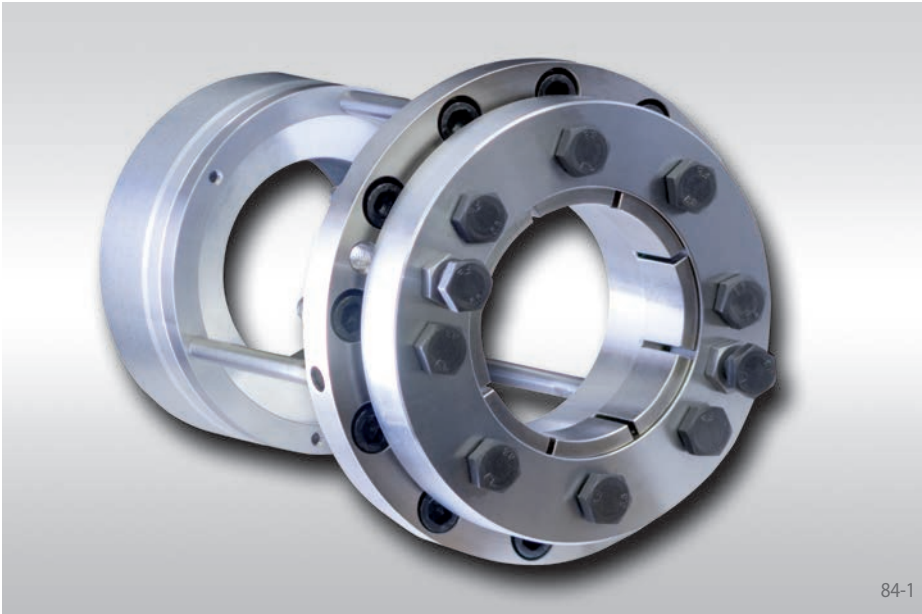

Features

- Provides a mechanical connection, support and centring between rotor and machine shaft
- Backlash free, torsion-proof transmission of torque generated by the torque motor
- High true running accuracy
- Optimally configured contact pressure prevents undesirable deformation of hollow machine shafts
- Taper Collet chemically nickel-coated to prevent fretting corrosion
- Easily removable Cone Clamping Element, even after long periods of operation
- Centring bush can be mounted from the B-side of the torque motor

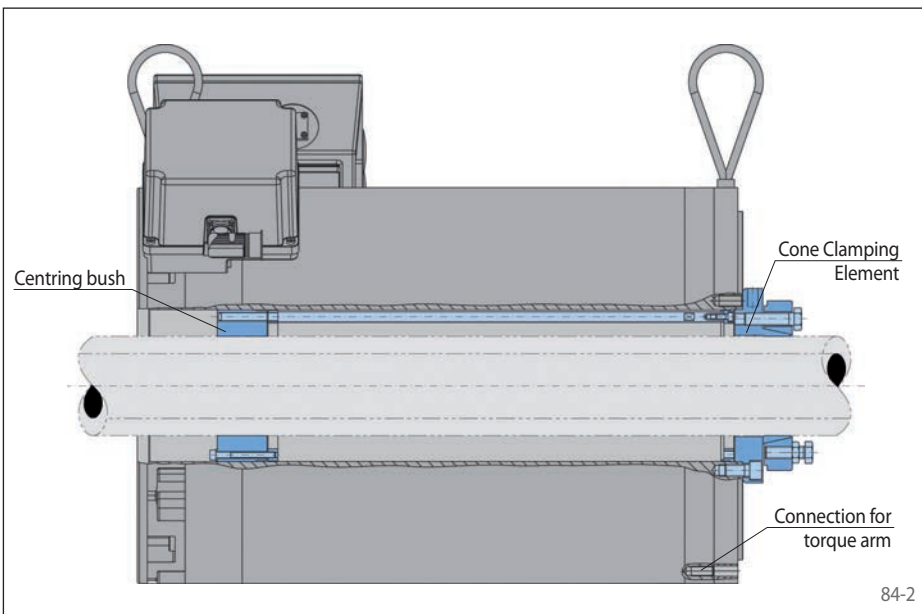

Configuration

The Clamping System RTM 607 consists of a Cone Clamping Element and a centring bush. The Cone Clamping Element ensures that motor torque is transmitted reliably to the machine shaft and centres the torque motor on the drive side. A second centring unit consisting of an aluminium centring bush ensures good overall alignment of the torque motor with the machine shaft.

The centring bush is secured in its axial position with the aid of rods and a stop ring.

for SIEMENS complete torque motors 1FW3

for mounting and centring complete torque motors on shafts or hollow shafts

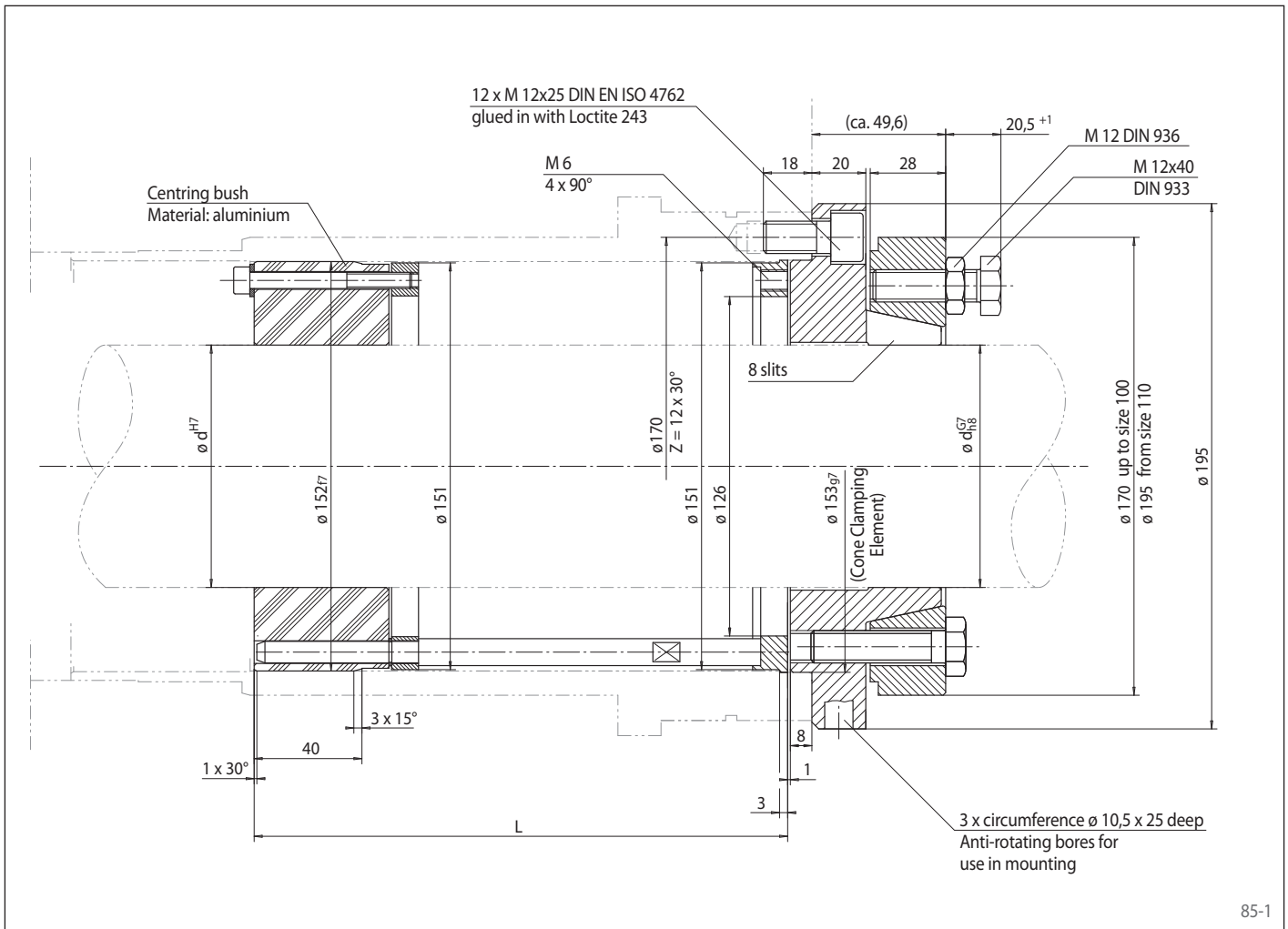

85-1

Dimensions

Size	for SIEMENS complete torque motors										
	1FW3150	1FW3152	1FW3154	1FW3155	1FW3156	1FW3201	1FW3202	1FW3203	1FW3204	1FW3206	1FW3208
d mm	L mm	L mm	L mm	L mm	L mm	L mm	L mm	L mm	L mm	L mm	L mm
60											
75											
80											
90	173	230	279	331	384	152	198	244	313	406	521
100											
110											
125											

Example for ordering

Clamping System RTM 607 for SIEMENS complete torque motors 1FW3 204 for shaft 90 mm:

- RTM 607-090, L = 313 mm

Clamping Systems RTM 608.1 and RTM 608.2

for complete torque motors

for mounting and centring complete torque motors on shafts or hollow shafts

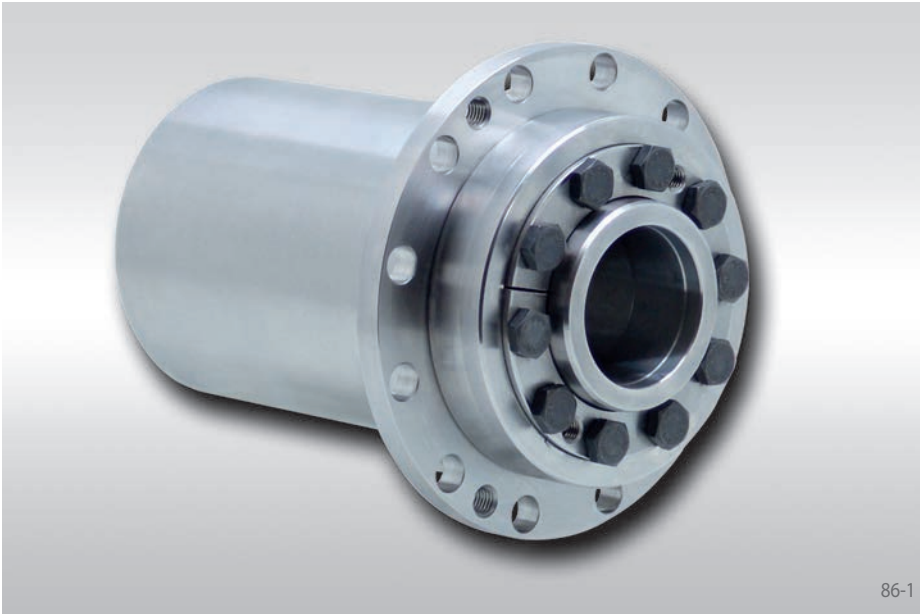

86-1

Features

- Provides a mechanical connection, support and centring between rotor and machine shaft
- Backlash free, torsion-proof transmission of torque generated by the torque motor
- High true running accuracy
- For inexpensive clamping on solid shafts
- Easily removable Cone Clamping Element, even after long periods of operation

Configuration

The Clamping System RTM 608 consists of a flange ring and a Shrink Disc RLK 608. The flange ring connects the torque motor to the machine shaft.

In contrast to the Clamping System RTM 607, the torque motor is centred on the Clamping System in a "flying" configuration. The Clamping System RTM 608 can be compared to a flange shaft, but offers the added advantage that a cylindrical shaft end remains following removal of the Clamping System RTM 608, facilitating trouble-free replacement of machine gaskets and bearings.

The Clamping System RTM 608 performs two functions in the area in contact with the machine shaft. Torque transmission is effected with the aid of a two-part Shrink Disc RLK 608. The second support point is configured with a glide bush, which helps prevent fretting corrosion resulting from microslippage (Fig. 86-2). In the case of short shaft ends, a Cone Clamping Element RLK 200 is used instead of the glide bush as a second support point in order to ensure the required true run accuracy of the torque motor in relation to the machine shaft (Fig. 86-3).

If you have an application for which the Clamping System RTM 608 is suited, please submit your enquiry, including the designation of the torque motor to be used as well as the shaft dimensions.

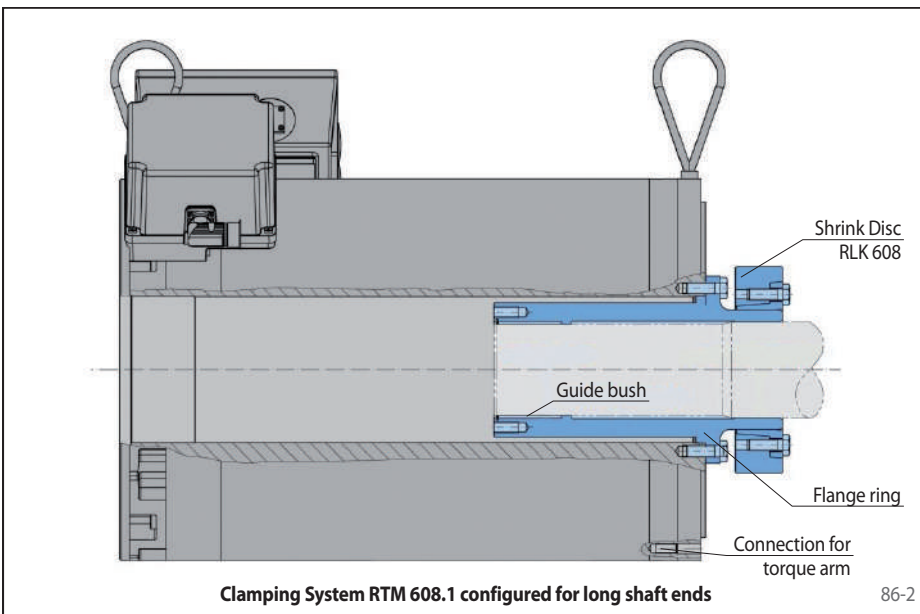

Clamping System RTM 608.1 configured for long shaft ends

86-2

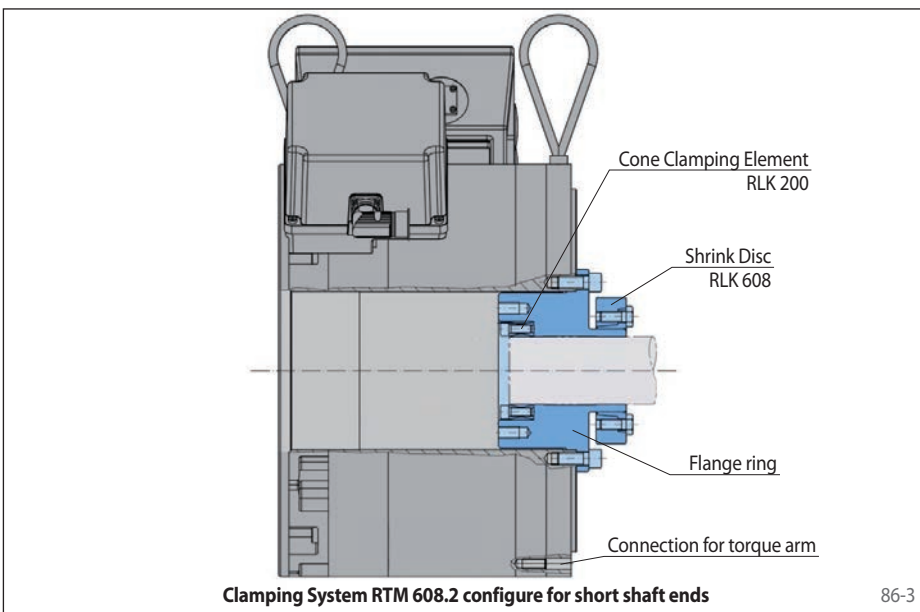

Clamping System RTM 608.2 configure for short shaft ends

86-3

Clamping Systems RTM 134.1 and RTM 134.2

for complete torque motors

for mounting and centring complete torque motors on shafts or hollow shafts

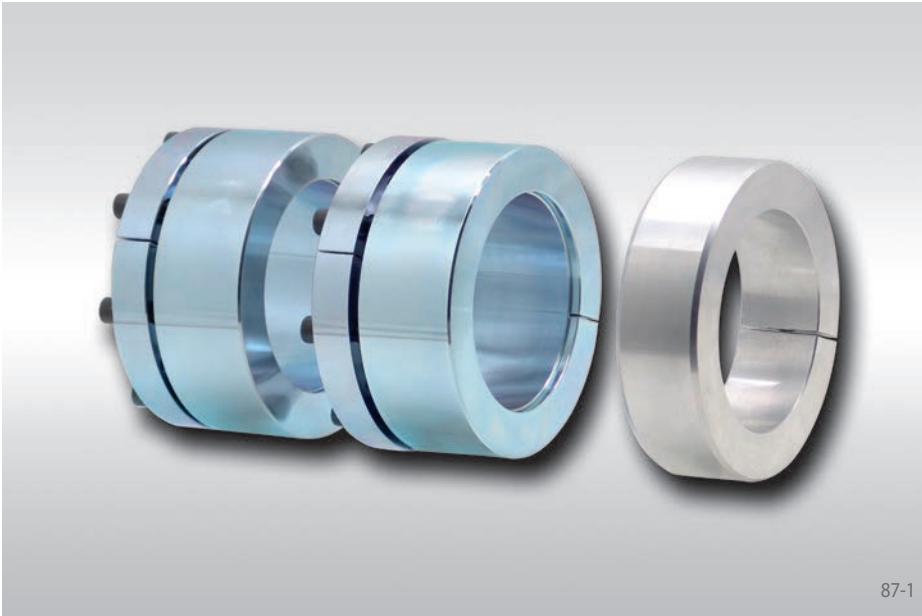

87-1

Features

- Provides a mechanical connection and centring between rotor and machine shaft. Support is provided by additional centring ring
- Backlash free, torsion-proof transmission of torque generated by the torque motor
- High true running accuracy
- Optimally configured contact pressure prevents undesirable deformation of the hollow rotor shaft of the torque motor and the hollow machine shaft
- Taper Collet galvanized and blue-chromed to prevent fretting corrosion
- Easily removable Cone Clamping Elements, even after long periods of operation
- Cone Clamping Elements can be mounted from the B-side of the torque motor

Configuration

Depending on the amount of torque to be transmitted between the machine shaft or hollow shaft and the torque motor, either one or two Cone Clamping Elements are used for torque transmission and a centring ring as a second support point are used. The Cone Clamping Elements have been developed in keeping the specific requirements of torque motors. The taper angle is designed in such a way that the Cone Clamping Elements can be removed easily, even after extended periods of operation, and no undesirable contact pressures cause indentations on the torque motor rotor shaft, which is ordinarily a thin-walled element.

The torque motor manufacturer should be consulted prior to installing this Clamping System. Therefore, we request submission of your enquiry in the event that a Clamping System this kind is considered suitable for your application.

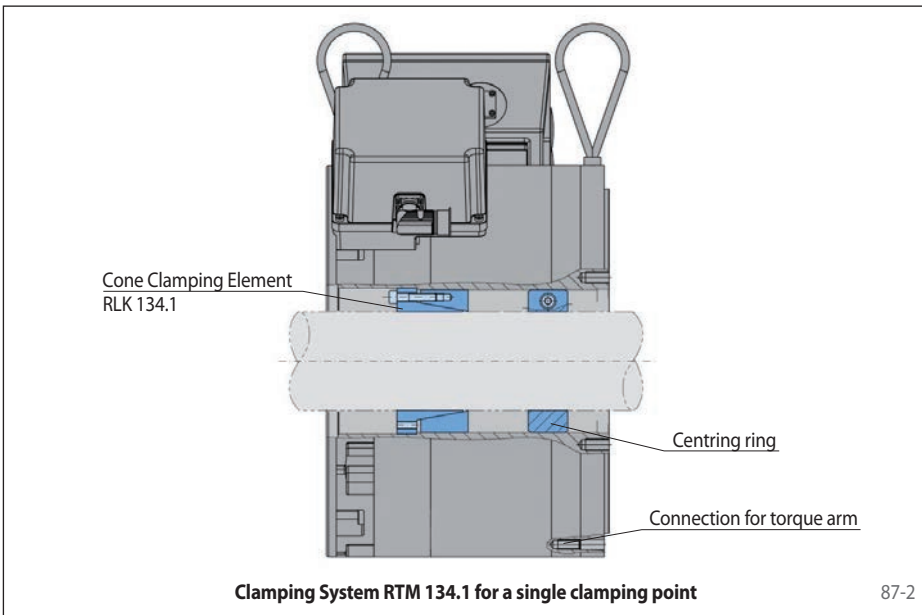

87-2

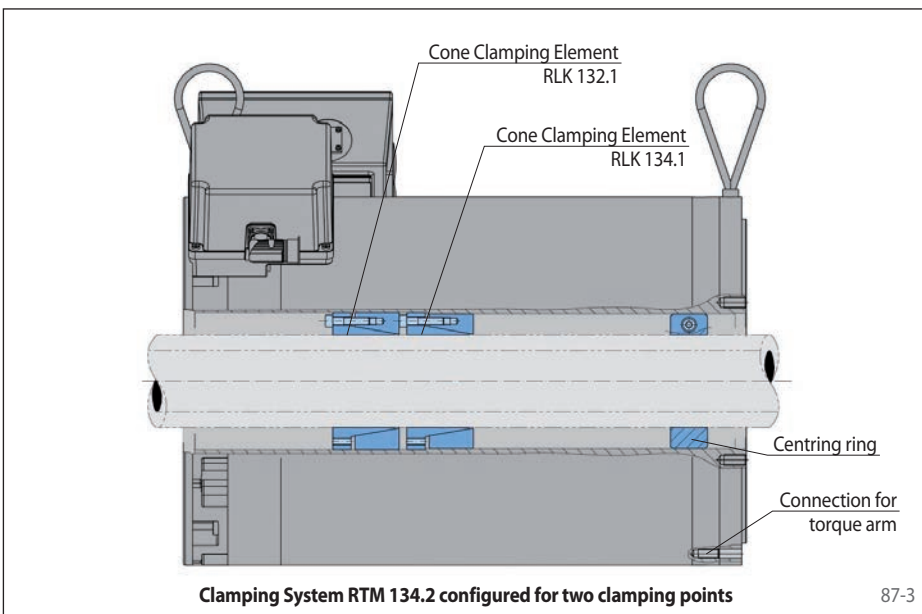

87-3



88-1

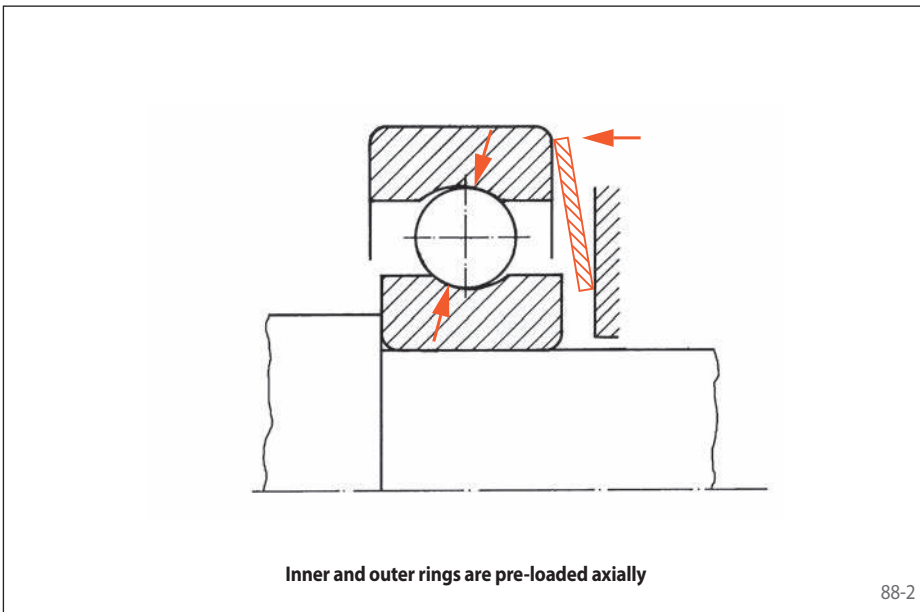

88-2

Conditions for most favourable effect

The effect of axial pre-loading depends on certain conditions:

- The axial pressure must be applied to the whole outer race.
- Axial variations and length tolerances within the components of the machine should have only the very slightest effect on the applied spring force.
- The axial pre-loading must be done with a load suitably adapted to the size of the bearing.

Protection of Bearings subject to vibration when non-rotating

The spring axial location also eliminates damage as a result of vibration in non-rotating bearings. This type of damage is well known in electric motors for auxiliary drives in ships and vehicles. If the auxiliary drives is stationary, the rotor can vibrate in the bearing, due to the vibration of the ship or vehicle. In these conditions the balls beat in the races of the bearing rings and cause wear. This is why leading manufacturers use only ball bearings, the radial play of which is removed by Star Spring Washers, so preventing any vibration of the rotor. The reason for damage is then completely eliminated.

Features

- RINGSPANN Star Spring Washers are particularly light spring elements with linear or not-linear spring characteristic. They are suitable for application as pressure elements in precision machines and as pressure springs for taking up free movement, and for reducing noise in ball bearings.
- The very large axial movement of the spring guarantees that considerable axial variations and length tolerances can be accommodated without much deviation from the nominal value of the axial force of the Star Spring Washer.
- Because of the large axial variations of the spring it is often possible to achieve the desired effect with a single Star Spring Washer.
- Their spring load corresponds with the optimum values of the relevant bearing sizes.

Service Life

Ball bearings give longer service if the inner and outer rings are pre-loaded axially (figure 88-2). This fact has been known for a long time. This axial preloading by RINGSPANN Star Spring Washers eliminates radial play in the ball bearings. This effects a better distribution of the radial load to be transmitted onto the bearing rings and therefore increases the length of service life of the bearing.

Silent Running

High speed machines, particularly small electric motors, create special problems for the designer regarding silent running. Extensive trials in this field have shown, that in the main, noise originates in the ball bearings, and that the application of the exact amount of axial pressure suitable for each job reducing noise effectively.

as ball bearing compensating discs for taking up free movement in bearings

Bearing of an internal grinding spindle

Spindle ball bearings are used as bearing support for grinding spindles. Bearings of this kind exhibit maximum tracking accuracy at high rotation speeds.

The specific properties of these bearings can be fully exploited only if the bearings are pre-clamped with a precisely defined force.

RINGSPANN Star Springs Washers enable you to realise the required pre-clamping force of the spindle bearings with a high degree of precision.

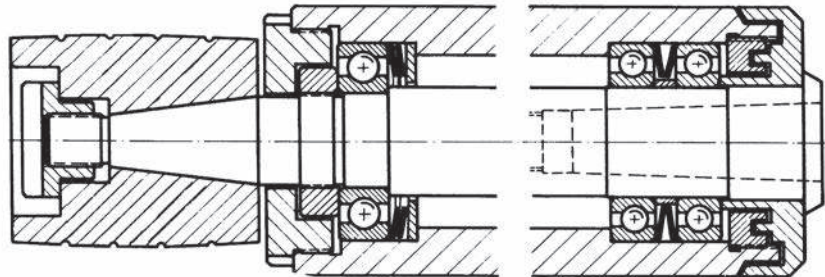

Bearing of an internal grinding spindle

89-1

Pressure spring for ball bearing

Silent running is a particular requirement for electric motors. For this purpose a RINGSPANN Star Spring Washer acts to pre-load the outer race of the bearing as illustrated.

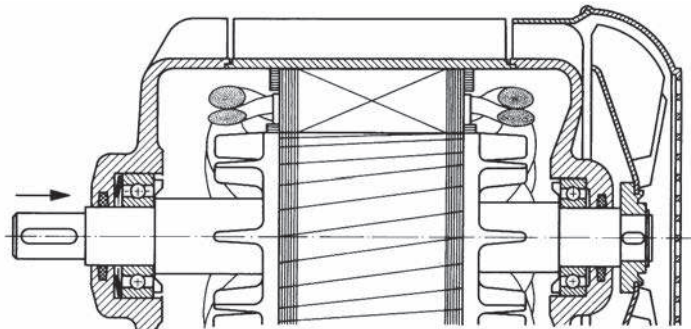

Pressure spring for ball bearing

89-2

Accommodating length tolerances

As shown in this example the RINGSPANN Star Spring Washer fitted between output shaft and NILOS sealing ring makes it possible to accommodate wide axial tolerances.

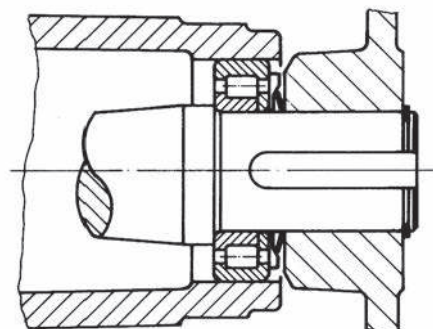

Accommodating length tolerances

89-3

as ball bearing compensating discs for taking up free movement in bearings

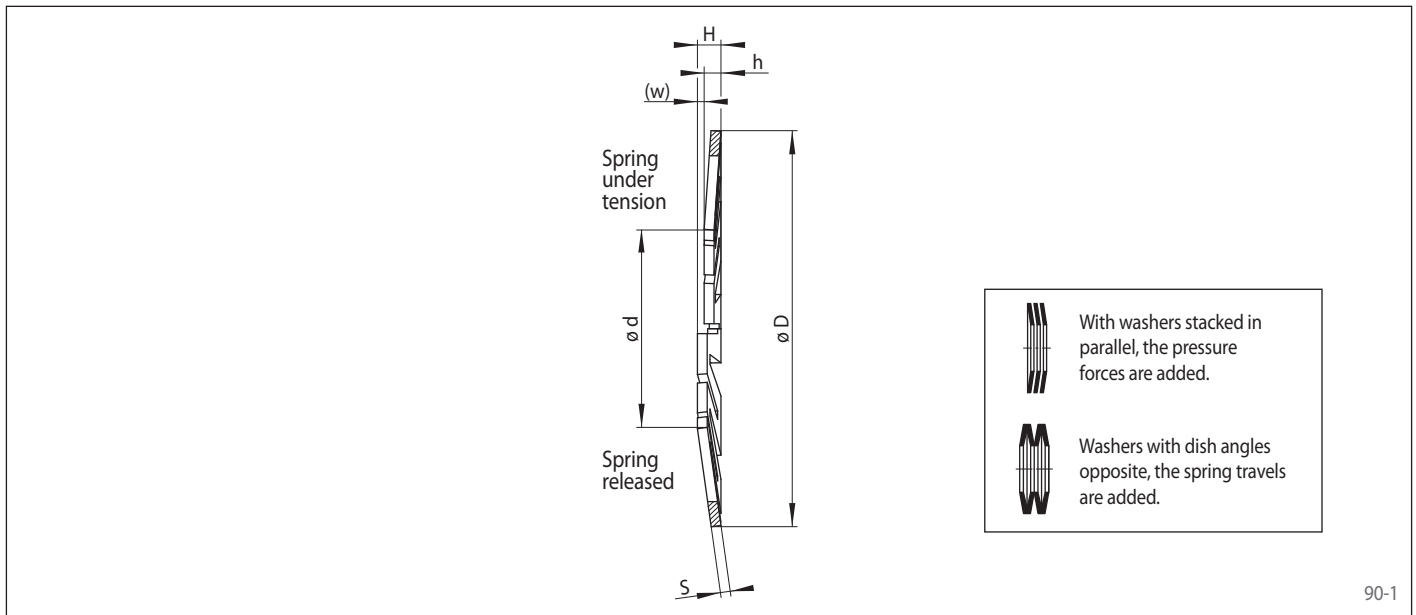

90-1

For ball bearing					Dimension			Height		Tolerance for h	Spring travel	Pressure	Spring const.	Article number
					D mm	d mm	s mm	released H mm	under pressure h mm					
				624	12,7	5,3	0,3	1,1	0,7	± 0,15	0,4	14	35	012001
634	E 3	E 4	E 5	625	15,7	7,5	0,3	1,1	0,7	± 0,15	0,4	9	23	015001
635			626	607	18,7	7,5	0,3	1,4	0,7	± 0,15	0,7	10	14	018001
635			626	607	18,7	9,2	0,3	1,2	0,7	± 0,15	0,5	11	22	018002
	E 6				20,7	10,5	0,3	1,3	0,7	± 0,15	0,6	7	12	020001
627	E 7			608	21,7	11	0,5	1,6	0,9	± 0,15	0,7	34	49	021001
	E 8			609	23,7	11	0,5	1,8	1,0	± 0,2	0,8	33	41	023001
629			6000		25,7	11	0,5	2,0	1,0	± 0,2	1,0	31	31	025001
629			6000		25,7	13,5	0,5	1,7	1,0	± 0,2	0,7	30	43	025002
16100	E 9	E 10	6001		27,7	15	0,65	1,9	1,1	± 0,2	0,8	52	65	027001
16101	E 13			6200	29,7	15	0,66	2,1	1,1	± 0,21	1,0	38	38	029001
	E 11	E 12		6201	31,7	15	0,65	2,3	1,1	± 0,2	1,2	46	38	031001
16002			6002	6201	31,7	18	0,65	2,0	1,1	± 0,21	0,9	36	40	031002
16003	E 14	E 15	6003	6202	34,7	20	0,9	2,4	1,4	± 0,2	1,0	89	89	034001
					36,7	20	0,9	2,6	1,4	± 0,21	1,2	92	77	036001
	E 16				37,7	20	0,9	2,7	1,4	± 0,2	1,3	84	65	037001
	E 19	L 17a	Bo 15	6203	39,7	20	0,9	2,9	1,4	± 0,2	1,5	81	54	039001
	E 19			6203	39,7	23	0,9	2,6	1,4	± 0,2	1,2	103	86	039002
16004			6004	6302	41,7	27	0,9	2,4	1,4	± 0,2	1,0	76	76	041001
		EA 17	Bo 17		43,5	27	0,9	2,6	1,4	± 0,2	1,2	68	57	043001
16005	E 20	L 20	6005	6204	46,5	27	0,9	2,9	1,4	± 0,2	1,5	74	49	046001
16005			6005		46,5	30	0,9	2,6	1,4	± 0,2	1,2	72	60	046002
	M 20	L 25	6205	6304	51,5	35	0,9	2,6	1,4	± 0,2	1,2	61	51	051001
16006			6006		54,5	35	1,15	3,1	1,7	± 0,25	1,4	98	70	054001
16007	L 30	6007	6206	6305	6403	61	40	1,15	3,3	± 0,25	1,6	110	69	061001
16008		6008			67	45	1,15	3,4	1,7	± 0,25	1,7	90	53	067001
			6207	6306	6404	71	45	1,15	3,8	± 0,25	2,1	110	52	071001
16009		6009			74	50	1,15	3,6	1,7	± 0,25	1,9	130	68	074001

Mounting

Generally it will be found most suitable for the Star Spring Washer to work on the outer ring of the ball bearing. The Star Spring Washer outside diameters given in the following table correspond therefore with the ball bearing outside diameters. The RINGSPANN design with slots and dished shape guarantees even axial pressure on the whole outer race. If an axial pressure

is applied to the shaft in one direction only, the Star Spring Washer must be mounted in such a way that there is no axial pressure on it (figure 89-2). If the axial pressures vary or are in both directions, a Star Spring Washer has to be mounted both sides of the ball bearings. In this case and in any doubtful cases we will be pleased to submit an installation proposal.

as ball bearing compensating discs for taking up free movement in bearings

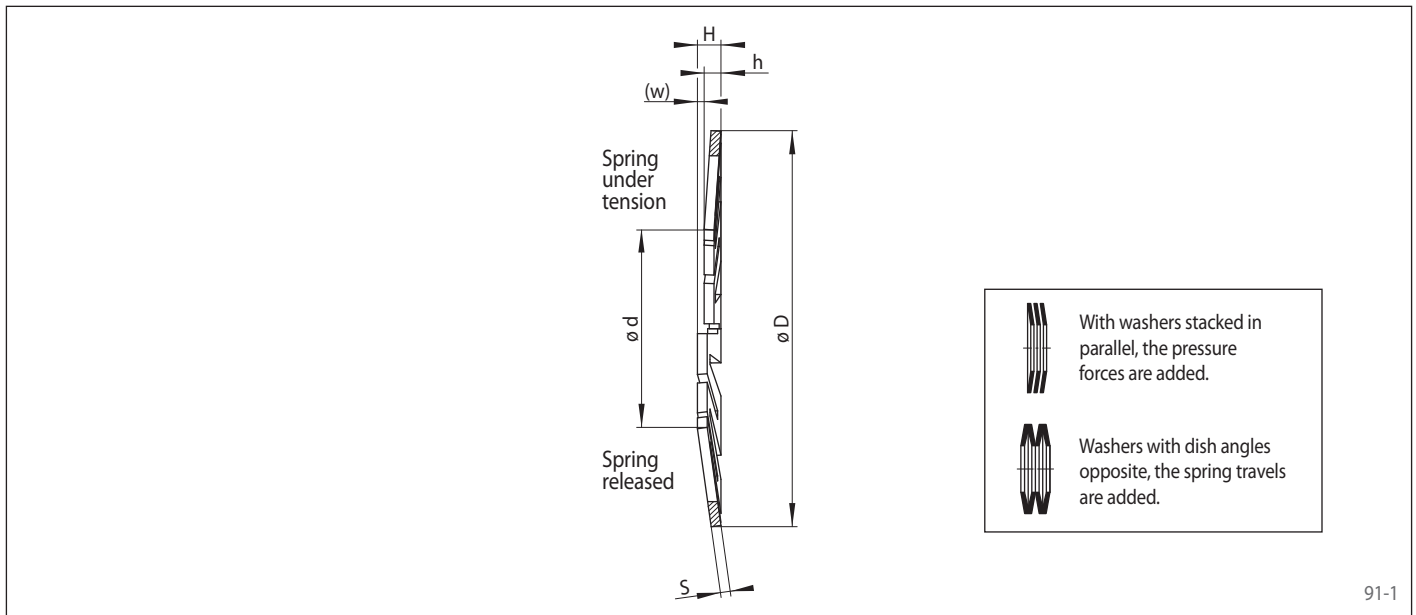

91-1

For ball bearing					Dimension			Height		Tolerance for h	Spring travel	Pressure	Spring const.	Article number
					D mm	d mm	s mm	released H mm	under pressure h mm					
16010	6010	6208	6307	6405	79	58	1,15	3,3	1,7	± 0,25	1,6	290	Diminishing spring characteristic	079001
		6209			84	63	1,15	3,3	1,7	± 0,25	1,6	320		084001
16011	6011	6210	6308	6406	89	63	1,15	3,8	1,7	± 0,25	2,1	290		089001
16012	6012				94	68	1,15	3,8	1,9	± 0,4	1,9	260		094001
16013	6013	6211	6309	6407	99	73	1,15	3,8	1,9	± 0,4	1,9	280		099001
16014	6014	6212	6310	6408	109	78	1,15	4,2	2,0	± 0,4	2,2	180		109001
16015	6015				114	83	1,15	4,2	2,0	± 0,4	2,2	200		114001
		6213	6311	6409	119	88	1,15	4,2	2,0	± 0,4	2,2	270		119001
16016	6016	6214			124	93	1,15	4,2	2,0	± 0,4	2,2	250		124001
16017	6017	6215	6312	6410	129	98	1,15	4,2	2,0	± 0,4	2,2	250		129001
16018	6018	6216	6313	6411	139	98	1,25	5,3	2,3	± 0,5	3,0	330		139001
16019	6019				144	103	1,25	5,3	2,3	± 0,5	3,0	330		144001
16020	6020	6217	6314	6412	149	108	1,25	5,3	2,3	± 0,5	3,0	370		149001
16021	6021	6218	6315	6413	158	118	1,5	5,5	2,5	± 0,5	3,0	410		158001
16022	6022	6219	6316		168	123	1,5	6	2,7	± 0,5	3,3	470		168001
16024	6024	6220	6317	6414	178	133	1,5	6	2,7	± 0,5	3,3	600		178001
		6221	6318	6415	188	138	2,1	7	3,3	± 0,5	3,7	520		188001
16026	6026	6222	6319	6416	198	143	2	7,5	3,3	± 0,5	4,2	660		198001
16028	6028			6417	208	163	2	6,2	3,0	± 0,5	3,2	1160		208001
		6224	6320		213	168	2	6,4	3,1	± 0,5	3,3	1120		213001
16030	6030		6321	6418	223	183	2	6,1	3,0	± 0,5	3,1	1200		223001
		6226			228	188	2	6,2	3,0	± 0,5	3,2	1160		228001
16032	6032		6322		238	198	2	6,4	3,1	± 0,5	3,3	1120		238001
		6228			248	211	2	6,2	3,0	± 0,5	3,2	1160		248001
16034	6034		6324		258	223	2	6,2	3,0	± 0,5	3,2	1180		258001

Explanation concerning the table

Apart from the listed ball bearing series the Star Spring Washers can also be used for series 32, 33, 42, 72 and 73. Pressure F is attained at height h. The spring constant c, i.e. the pressure increase per mm spring travel can only be given up to size 74 x 50 x 1,15.

With larger Star Spring Washers the spring characteristic is not linear but diminishing. With tolerances of the installation height h the pressure F therefore changes even less than with smaller washers. Up to size 129 x 98 x 1,15 the springs can be supplied plated against corrosion.

Example for ordering

Star Spring Washer for ball bearings of series 16011:

- Article number 1052-089001

Germany**RINGSPANN GmbH**

Schaberweg 30 - 38, 61348 Bad Homburg, Germany
+49 61 72 2750
info@ringspann.de • www.ringspann.de

RINGSPANN RCS GmbH

Hans-Mess-Straße 7, 61440 Oberursel, Germany
+49 61 72 67 6850
info@ringspann-rcs.de • www.ringspann-rcs.de

France**SIAM - RINGSPANN S.A.**

23 rue Saint-Simon, 69009 Lyon, France
+33 4 78 83 5901
info@siam-ringspann.fr • www.ringspann.fr

Great Britain, Ireland**RINGSPANN (U.K.) LTD.**

3, Napier Road, Bedford MK41 0QS, Great Britain
+44 12 34 34 25 11
info@ringspann.co.uk • www.ringspann.co.uk

Italy**RINGSPANN Italia S.r.l.**

Via A.D. Sacharov, 13, 20812 Limbiate (MB), Italy
+39 02 93 57 12 97
info@ringspann.it • www.ringspann.it

Netherlands, Belgium, Luxembourg**RINGSPANN Benelux B.V.**

Nieuwenkampsmaten 6- 15, 7472 DE Goor,
Netherlands • +31 547 26 13 55
info@ringspann.nl • www.ringspann.nl

Austria, Hungary, Slovenia**RINGSPANN Austria GmbH**

Kleegasse 9, 2624 Breitenau, Austria
+43 26 35 62446
info@ringspann.at • www.ringspann.at

Poland

Radius-Radpol Wiecheć Sp.J.
ul. Kolejowa 16 b, 60-185 Skórzewo, Poland
+48 61 814 39 28 • info@radius-radpol.com.pl
www.radius-radpol.com.pl

Romania, Bulgaria, Moldova

S.C. Industrial Seals and Rolls S.R.L.
Str. Depozitelor, No. 29, 110078 Pitesti, Romania
+4 0751 22 82 28
mihai@isar.com.ro • www.isar.com.ro

Russia, Belarus, Kazakhstan

RINGSPANN Office
Pod'jermnaja Street 12, Building 1, Floor 4,
Office 426, 109052 Moscow, Russia
+7 495 911 86 48
Denis.Kalashnikov@ringspann.com
www.ringspann.com.ru

Sweden, Finland, Denmark, Norway,**Baltic states****RINGSPANN Nordic AB**

Industrigatan 7, 61933 Trosa, Sweden
+46 156 190 98
info@ringspann.se • www.ringspann.se

Switzerland**RINGSPANN AG**

Sumpfstrasse 7, P.O. Box 3320, 6303 Zug,
Switzerland • +41 41 748 0900
info@ringspann.ch • www.ringspann.ch

Spain, Portugal**RINGSPANN IBERICA S.A.**

C/Uzbina, 24-Nave E1, 01015 Vitoria, Spain
+34 945 22 77 50
info@ringspann.es • www.ringspann.es

Czech Republic, Slovakia

Ing. Petr Schejbal
Mezivří 1444/27, 14700 Prag, Czech Republic
+420 222 96 90 22
Petr.Schejbal@ringspann.cz • www.ringspann.com

Ukraine

"START-UP" LLC.
Saltivske Hwy, 43, letter G-3, office 101,
Kharkiv 61038, Ukraine • +38 057 717 03 04
start-up@start-up.kh.ua • www.start-up.kh.ua

Asia

Australia, New Zealand**RINGSPANN Australia Pty Ltd**

Unit 5, 13A Elite Way, Carrum Downs Vic 3201,
Australia • +61 3 9069 0566
info@ringspann.com.au • www.ringspann.com.au

China, Taiwan**RINGSPANN Power Transmission (Tianjin) Co., Ltd.**

No. 21 Gaoyan Rd., Binhai Science and Technology
Park, Binhai Hi-Tech Industrial, Development Area,
Tianjin, 300458, P.R. China • +86 22 5980 31 60
info.cn@ringspann.cn • www.ringspann.cn

India, Bangladesh, Nepal**RINGSPANN Power Transmission India Pvt. Ltd.**

GAT No: 679/2/1, Village Kuruli, Taluka Khed, Chakan-
Alandi Road, Pune - 410501, Maharashtra, India
+91 21 35 67 75 00 • info@ringspann-india.com
www.ringspann-india.com

Singapore, ASEAN**RINGSPANN Singapore Pte. Ltd.**

143 Cecil Street, #17-03 GB Building,
Singapore 069542 • +65 9633 6692
info@ringspann.sg • www.ringspann.sg

South Korea**J & N TECH**

Gangnam Teheran-Lo 82 Ghil 15, 2nd Fl. #8,
Seoul 06178, South Korea • +82 10 54 961 368
schinng@outlook.com • www.ringspann.kr

America

Brazil

Antares Acoplamentos Ltda.
Rua Evaristo de Antoni, 1222, Caxias do Sul, RS,
CEP 95041-000, Brazil • +55 54 32 18 68 00
vendas@antaresacoplamentos.com.br
www.antaresacoplamentos.com.br

USA, Canada, Mexico, Chile, Peru**RINGSPANN Corporation**

10550 Anderson Place, Franklin Park, IL 60131, U.S.A
+1 847 678 35 81
info@ringspanncorp.com • www.ringspanncorp.com

Africa and Middle East

Egypt

Shofree Trading Co.
218 Emtedad Ramsis 2, 2775 Nasr City, Cairo, Egypt
+20 2 20 81 20 57
info@shofree.com • www.ringspann.com

Israel

G.G. Yarom Rolling and Conveying Ltd.
6, Hamaktesh Str., 58810 Holon, Israel
+972 3 557 01 15
noam_a@gg.co.il • www.ringspann.com

South Africa, Sub-Saharan**RINGSPANN South Africa (Pty) Ltd.**

96 Plane Road Spartan, Kempton Park,
P.O. Box 8111 Edenglen 1613, South Africa
+27 11 394 18 30
info@ringspann.co.za • www.ringspann.co.za

Iran

Persia Robot Machine Co. Ltd.
4th Floor, No 71, Mansour St, Motahari Avenue,
Tehran 15957, Iran • +98 21 88 70 91 58-62
info@persiarobot.com • www.ringspann.com

Maghreb, West Africa**SIAM - RINGSPANN S.A.**

23 rue Saint-Simon, 69009 Lyon, France
+33 4 78 83 59 01
info@siam-ringspann.fr • www.ringspann.fr