

Shaft Couplings

Flange Couplings • Cone Clamping Couplings • Gear Couplings • Disc Couplings
Flexible Couplings • Grid Couplings • Pin and Bush Couplings • Jaw Couplings



Edition 2019/2020

Table of Contents

Shaft Coupling Introduction

Introduction

Rigid Shaft Couplings	Nominal torques T_{KN} [Nm]	Torque load			Transmission of torque	
		uniform	not uniform	shocks, very rough operation	backlash free	overload holding / fail safe

Tru-Line Flange-Couplings

RFK ... TBO with backlash free cone clamping connection	2500 - 625 000	●●	●●	●●	●●	
---	----------------	----	----	----	----	--

Cone Clamping Couplings

RWK ... EEO with backlash free connection of two shaft ends	130 - 7600	●●	●●	●●	●●	
---	------------	----	----	----	----	--

Torsionally Rigid Shaft Couplings

Torsionally Rigid Shaft Couplings	Nominal torques T_{KN} [Nm]	Torque load			Transmission of torque	
		uniform	not uniform	shocks, very rough operation	backlash free	overload holding / fail safe

Gear Couplings

RDZ ... DTO with double engagement gearing	1330 - 391 500	●●	●●	●●	●	●●
RDZ ... DFO with single engagement gearing	1330 - 391 500	●●	●●	●●	●	●●
RDZ ... EEO with continuous sleeve, double engagement gearing	10 - 380	●●	●●	●	●	●●

Disc Couplings

RDL ... DSO with single disc pack	96 - 18700	●●	●●	●●	●●	●●
RDL ... DSZ with double disc packs with spacer	96 - 18700	●●	●●	●●	●●	●●
RDL ... DSA with double disc packs, design according to API 610	96 - 18700	●●	●●	●●	●●	●●

Flexible Couplings

RDA ... ESO with keyway	2 - 8000	●●	●●	●	●	●●
RDA ... ESO with backlash free clamping connection	2 - 32	●●	●●	●	●	●●
RDA ... ESO with mounting flange with through bores	85 - 8000	●●	●●	●	●	●●

RDA ... ESO - Combination of hub designs

RDA ... ESO - Example hub combination

Elastic Shaft Couplings	Nominal torques T_{KN} [Nm]	Torque load			Transmission of torque	
		uniform	not uniform	shocks, very rough operation	backlash free	overload holding / fail safe

Grid Couplings

RES ... EYO with horizontally split cover	48 - 335 500	●●	●●	●●	●	
RES ... ETO with vertically split cover	48 - 169 000	●●	●●	●●	●	

Pin and Bush Couplings

REB ... DCO	95 - 1 299 500	●●	●●	●●	●	●●
-------------	----------------	----	----	----	---	----

Jaw Couplings



REK ... DQO with radially mountable elastomer cushions	5300 - 169 000	●●	●●	●●	●	●●
REK ... DGO with enclosed elastic elements	34 - 7000	●●	●●	●●	●	●●
REK ... DHO with enclosed elastic elements and two piece hub	160 - 7000	●●	●●	●●	●	●●
REK ... DGZ with enclosed elastic elements and spacer	60 - 7000	●●	●●	●●	●	●●
REK ... DCO with curved jaws	9,6 - 3430	●●	●●	●●	●	●●
REK ... ECO with curved jaws	31 - 3 150	●●	●●	●●	●	●●

Shaft Coupling Technology Details

Technical points

Ordering information for bore in imperial dimension

Questionnaires

														Page		
														4		
Bore diameter [mm]	Installation / alignment			Permissible misalignments			Maintenance			Ambient conditions		Damping element	Atex 	Complies with		Page
	rigid / excellent	rigid / roughly	flexible	axial	radial	angular	free	low	wear parts	hazardous	aggressive			API 610	API 671	
25 - 350	●●						●●				*					6
14 - 100	●●						●●				*					8
15 - 330	●●	●	●●	●●	●●	●●		●●			*	*				10
15 - 405	●●	●	●	●●		●●		●●			*	*				12
6 - 65	●	●	●●	●●	●●	●●	●●				*					14
10 - 165	●●	●	●	●●		●●	*	●	●●		*	*				18
10 - 165	●●	●	●●	●●	●●	●●	*	●	●●		*	*				20
8 - 255	●●	●	●●	●●	●●	●●	*	●	●●		*	*		●●	●	22
5 - 140	●●	●●	●●		●●	●●	●●				*					24
5 - 35	●●	●●	●●		●●	●●	●●				*					26
-	●●	●●	●●		●●	●●	●●				*					28
														30		
														31		
Bore diameter [mm]	Installation / alignment			Permissible misalignments			Maintenance			Ambient conditions		Damping element	Atex 	Complies with		Page
	rigid / excellent	rigid / roughly	flexible	axial	radial	angular	free	low	wear parts	hazardous	aggressive			API 610	API 671	
18 - 420	●●	●	●	●●	●●	●●	●	●	●●		*	*	●●			32
18 - 360	●●	●	●	●●	●●	●●	●	●	●●		*	*	●●			34
15 - 600	●●	●●	●	●●	●●	●●		●	●●	●●	*	●●	●●			36
30 - 340	●●	●	●	●●	●●	●●		●	●●	●●	*	●●	●●			40
9 - 100	●●	●	●	●●	●●	●●		●		●●	*	●●	●●			44
14 - 100	●●	●	●	●●	●●	●●		●	●●	●●	*	●●	●●			48
9 - 100	●●	●	●	●●	●●	●●		●	●	●●	*	●●	●●			52
6 - 110	●●	●	●	●●	●●	●●		●		●●	*	●●	●●			56
10 - 115	●●	●	●	●●	●●	●●		●		●●	*	●●	●●			62
														Page		
														64		
														68		
														70		

Key ●● true, well suited ● conditionally suitable, conditionally applicable * on request

Introduction

Not shiftable couplings by RINGSPANN

For over 60 years, RINGSPANN has been renowned as a provider of couplings, beginning with the patented L-coupling from 1956, which is still offered today as model RDA ... ESO. Back then RINGSPANN was able to offer drive system engineers a compact, torsionally rigid flexible coupling based on the Oldham principle that can compensate large parallel and angular misalignments in small spaces.

RINGSPANN has since expanded its coupling range and can now offer the not shiftable couplings for almost all applications.

For example, the rigid Tru-Line Flange-Couplings of the RFK ... TBO model with a special Shaft-Hub-Connection allows for freely hanging motor gear units with a torque support to be coupled to conveyor belt pulleys without fretting corrosion while accommodating significant rotating bending moment stress.

RINGSPANN offers equally suitable couplings for applications where it is critical for torque to be transmitted through a torsionally rigid connection without backlash while still being able to accommodate for shaft misalignment.

Additionally RINGSPANN can offer solutions where the torsional rigidity is beneficial for the application but needs to be adapted with the use of elastomers.

With Freewheels, Brakes, Shaft-Hub-Connections and Overload Clutches, RINGSPANN offers an exceptionally wide range of power transmission components that can be applied in drive-trains.



RFK ... TBO



RWK ... EEO



RDZ ... DTO



RDZ ... DFO



RDZ ... EEO



RDL ... DSO



RDL ... DSZ



RDL ... DSA



RDA ... ESO



RDA ... ESO



RDA ... ESO



RES ... EYO



RES ... ETO



REB ... DCO



REK ... DQO



REK ... DGO



REK ... DHO



REK ... DGZ



REK ... DCO



REK ... ECO

backlash free cone clamping connection

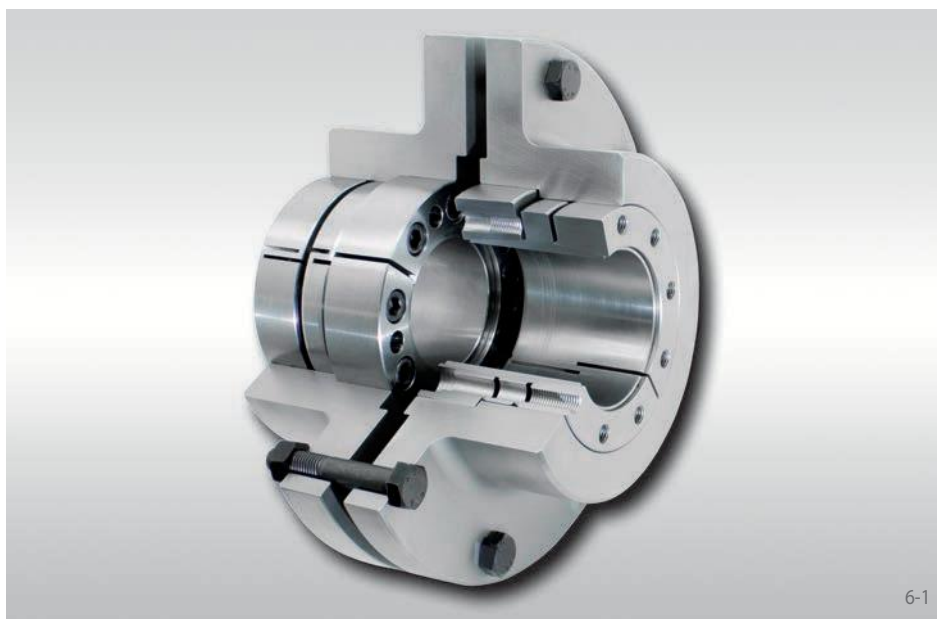

6-1

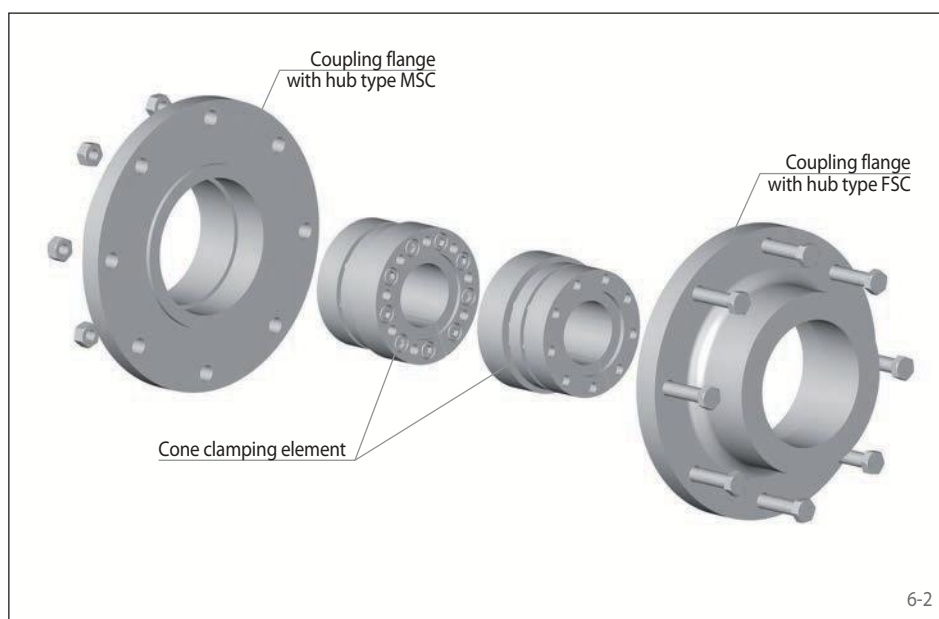

6-2

Transmissible torques

The transmissible torques listed on the following page are subject to the listed tolerances, surface finishes and material requirements. Please contact RINGSPANN in case of deviations.

Tolerances

- h8 for shaft diameters d_F or d_M

Surfaces

Average surface finish at the contact surfaces of the shafts $R_z = 10 \dots 25 \mu\text{m}$.

Materials

RINGSPANN is able to recommend suitable shaft materials using DIN 743 (12/2012 edition) taking the surface pressures for the Tru-Line Flange-Couplings RFK ... TBO into account.

Simultaneous transmission of torque, axial force and bending moment

Where there are combinations of axial forces and/or bending moments in the application in addition to the torque T_N , the max. transmissible torque will be reduced as compared to the values for $T_{K\text{max}}$ shown in the tables.

RINGSPANN will select the proper coupling for each application based upon the allowed transmissible torque under existing bending moment conditions. Our selection calculations are in accordance with the latest scientific knowledge and experience in the industry and will include the proper safety factor to prevent fretting corrosion. Please contact RINGSPANN.

Features

- Compact design
- Small axial space required for installation
- Quick disassembly for minimal downtime
- Large allowable shaft tolerance of h8
- Shafts are not weakened by keyways
- No fretting corrosion like with keyway connections
- Typical applications: Drive units and conveyor drives e.g. in mining

Order example

Order example	Code
Coupling design	RFK
Coupling size of smaller coupling half	0050
Type	TBO
Material of the hub: • Steel	STA
Hub A, type: • Flange with Female Pilot • Flange with Male Pilot	F M
Hub A, design: Frictional Shaft-Hub-Connection	SC
Bore diameter d_F or d_M	025
Hub B, type: • Flange with Female Pilot • Flange with Male Pilot	F M
Hub B, design: Frictional Shaft-Hub-Connection	SC
Bore diameter d_F or d_M	025

RFK 0050 TBO-STA-FSC025-MSC025

Order information

The coupling halves and the fasteners set can also be ordered separately. The indication of the coupling half corresponds to the size of the smaller coupling half.

backlash free cone clamping connection

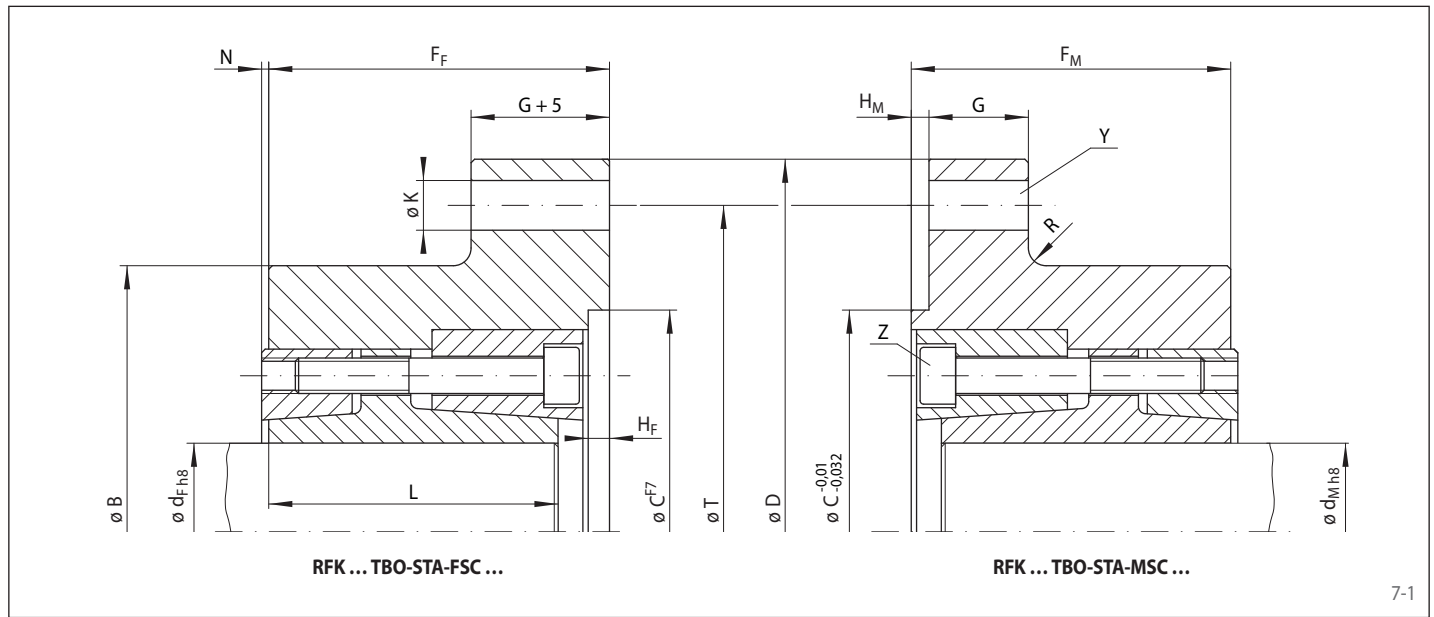

7-1

Tru-Line Flange-Coupling RFK Size	Shaft	Max. transmissible torque	B	C	D	FF	FM	G	HF	HM	K	L	N	R	T	Flange connection screws		Cone clamping screws		Weight FSC or MSC	
																Y*	Tightening torque	Z	Tightening torque		
FSC Female Pilot	MSC Male Pilot	dF or dM mm	Tkmax Nm	mm	mm	mm	mm	mm	mm	mm	mm	mm	mm	mm	mm	mm	Nm	Nm	kg		
0050	0050	min. 25 max. 50	2500 5250	120	100	190	70	65	10	5	3	11	60	5	10	160	8 x M 10 x 40	71	8 x M 8	42	7,5 6,8
0070	0070	min. 50 max. 70	6300 10000	170	150	260	88	81	15	5	3	15	75	5	15	230	8 x M 14 x 60	195	9 x M 10	83	32 30
0090	0090	min. 70 max. 90	16000 20000	200	180	320	103	96	25	7	5	18	90	6	15	280	8 x M 16 x 75	300	9 x M 12	144	39 37
0115	0115	min. 95 max. 115	28000 35500	230	300	400	115	105	30	10	6	25	100	8	40	350	8 x M 24 x 100	1020	7 x M 14	229	47 45
0140	0140	min. 115 max. 140	45000 56000	270	300	400	115	105	30	10	6	25	100	8	20	350	8 x M 24 x 100	1020	10 x M 14	229	55 51
0170	0170	min. 140 max. 170	90000 112000	330	300	560	145	135	36	12	8	32	128	10	30	480	18 x M 30 x 120	2030	11 x M 16	354	112 105
0210	0210	min. 170 max. 210	160000 200000	390	300	560	145	135	36	12	8	32	128	10	20	480	18 x M 30 x 120	2030	16 x M 16	354	137 125
0211	0211	min. 170 max. 210	160000 200000	430	350	630	145	135	40	12	8	32	128	10	20	550	18 x M 30 x 130	2030	16 x M 16	354	160 148
0250	0250	min. 210 max. 250	265000 315000	470	350	630	160	150	40	12	8	32	140	10	10	550	18 x M 30 x 130	2030	14 x M 20	692	199 183
0270	0270	min. 250 max. 270	375000 400000	510	550	710	179	169	40	12	8	32	158	10	30	630	24 x M 30 x 130	2030	16 x M 20	692	259 249
0290	0290	min. 270 max. 290	450000 490000	550	550	710	179	169	40	12	8	32	158	10	15	630	24 x M 30 x 130	2030	18 x M 20	692	286 275
0320	0320	min. 290 max. 320	520000 540000	580	550	750	200	190	40	12	8	32	180	10	15	680	28 x M 30 x 130	2030	20 x M 20	692	318 338
0350	0350	min. 320 max. 350	590000 625000	630	550	800	200	190	45	12	8	32	180	10	15	720	28 x M 30 x 150	2030	20 x M 20	692	401 380

Paired coupling halves of the same colour can be interchanged due to matching flange patterns. The maximum torques of the smaller coupling half apply.
 * Number of connection screws Y in accordance DIN EN ISO 4014 property class 10.9 or 12.9 for RFK 0050 TBO on pitch circle T.

Mounting

The installation and operating instruction for Tru-Line Flange-Couplings RFK ... TBO is available on request.



8-1

Features

- Compact design
- Easy to remove
- For shaft diameters ranging from 14 mm to 100 mm
- Rigid and backlash free connections of the shaft ends
- Shafts are not weakened by keyways
- No fretting corrosion like with keyway connections
- Transmission of torque and/or axial forces
- Typical applications: Connection of shaft sections e.g. with slitter winders in the paper industry

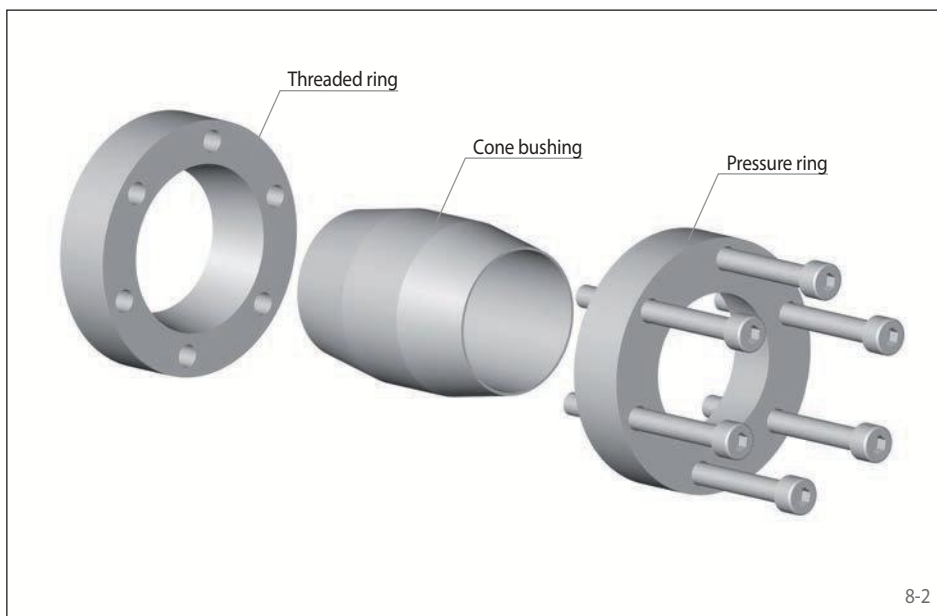

8-2

Order example

Order example	Code
Coupling design	RWK
Coupling size	0014
Type	EEO
Material of the hub: • Steel	STA
Hub, type: • standard	0
Hub, design: • Clamping ring hub, clamping screws from outside	SE
Bore diameter d	014

RWK 0014 EEO-STA-0SE014

Transmissible torques and axial forces

The transmissible torques and axial forces listed on the following page are subject to the listed tolerances, surface finishes and material requirements. Please contact RINGSPANN in case of deviations.

Tolerances

- h8 for shaft diameter d

Surfaces

Average surface finish at the contact surfaces of the shafts $R_z = 10 \dots 25 \mu\text{m}$.

Materials

The following apply to the shaft and the hub:

- E-module $\geq 170 \text{ kN/mm}^2$

Simultaneous transmission of torque and axial force

The transmissible torques $T_{K \max}$ which are shown in the table apply for axial forces $F_{ax \max} = 0 \text{ kN}$ and conversely, the indicated axial forces $F_{ax \max}$ apply to torques $T_{K \max} = 0 \text{ Nm}$. If torque and axial force are to be transmitted simultaneously, the transmissible torque and the transmissible axial force are reduced.

For a given axial force $F_{AN \max}$, the reduced torque $T_{K \max r}$ is calculated as:

$$T_{K \max r} = \sqrt{T_{K \max}^2 - (F_{AN \max} \cdot \frac{d}{2})^2}$$

For a given torque $T_{N \max}$, the reduced axial force $F_{ax \max r}$ is calculated as:

$$F_{ax \max r} = \frac{2}{d} \sqrt{T_{K \max}^2 - T_{N \max}^2}$$

$T_{K \max}$	= Max. transmissible torque of the coupling [Nm]
$T_{K \max r}$	= Reduced maximum torque of the coupling [Nm]
$T_{N \max}$	= Maximum torque occurring in the application [Nm]

$F_{AN \max}$	= Maximum axial force occurring in the application [kN]
$F_{ax \max}$	= Max. transmissible axial force [kN]
$F_{ax \max r}$	= Reduced axial force [kN]
d	= Shaft diameter [mm]

backlash free connection of two shaft ends

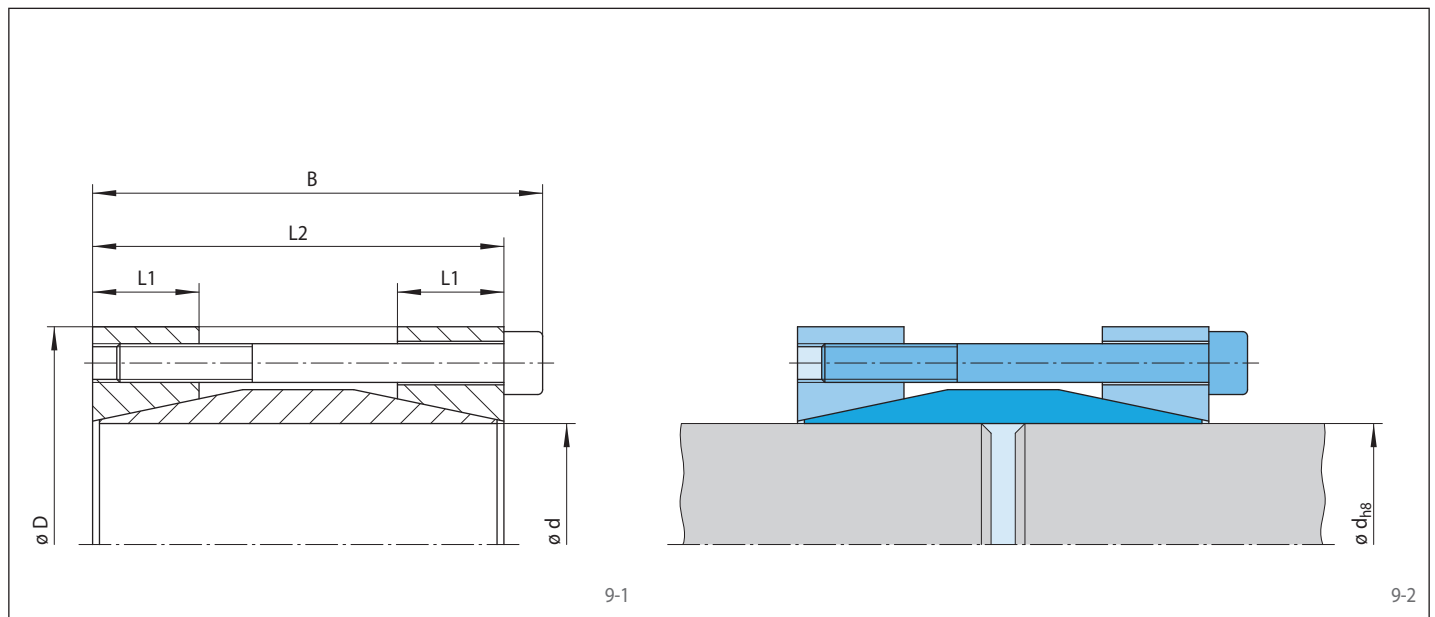

Coupling size d mm	Max. transmissible torque or axial force		Clamping screws				D mm	B mm	L1 mm	L2 mm	Weight kg
	$T_{K \max}$ Nm	$F_{ax \max}$ kN	Tightening torque M_S Nm	Number	Size	Length					
0014	130	18	16	4	M 6	45	45	56	15	50	0,38
0015	140	18	16	4	M 6	45	45	56	15	50	0,35
0016	150	18	16	4	M 6	45	45	56	15	50	0,37
0017	160	18	16	4	M 6	45	45	56	15	50	0,40
0018	160	17	16	4	M 6	45	50	56	15	50	0,45
0019	170	17	16	4	M 6	45	50	56	15	50	0,44
0020	180	18	16	4	M 6	45	50	56	15	50	0,44
0022	310	28	16	6	M 6	55	55	66	18	60	0,50
0024	330	27	16	6	M 6	55	55	66	18	60	0,63
0025	350	28	16	6	M 6	55	55	66	18	60	0,61
0028	340	24	16	6	M 6	55	60	66	18	60	0,75
0030	370	24	16	6	M 6	55	60	66	18	60	0,71
0032	520	32	37	4	M 8	70	75	83	20	75	0,14
0035	570	32	37	4	M 8	70	75	83	20	75	1,33
0038	620	32	37	4	M 8	70	75	83	20	75	1,20
0040	650	32	37	4	M 8	70	75	83	20	75	1,19
0042	990	47	37	6	M 8	80	85	93	22	85	1,80
0045	1050	46	37	6	M 8	80	85	93	22	85	1,72
0050	1200	48	37	6	M 8	80	90	93	22	85	1,80
0055	1700	61	37	8	M 8	80	95	93	22	85	2,00
0060	1950	65	37	8	M 8	80	100	93	22	85	2,17
0065	2150	66	37	8	M 8	80	105	93	22	85	2,60
0070	2800	80	73	6	M 10	80	115	110	35	100	4,10
0075	2900	77	73	6	M 10	80	120	110	35	100	4,30
0080	4200	100	73	8	M 10	80	125	110	35	100	4,48
0090	4700	100	73	8	M 10	80	135	110	35	100	5,20
0100	7600	150	126	8	M 12	100	155	132	40	120	6,00

Bending moments

Where there are bending moments in the application in addition to the torque $T_{N \max}$ or the axial force $F_{AN \max}$, the transmissible torque or transmissible axial force is reduced compared to the values for $T_{K \max}$ or $F_{ax \max}$ as listed in the table. Please contact RINGSPANN.

Mounting

The installation and operating instruction for Cone Clamping Coupling RWK ... EEO is available on request.

Gear Couplings RDZ ... DTO

torsionally rigid
double engagement gearing – lubricated



10-1

Features

- High nominal torques up to 391 500 Nm
- High misalignment capability
- Compensation of axial, radial and angular misalignments
- Double engagement allows smooth torque transmission
- Compact design due to inside turned hubs
- Complies with the AGMA standard (American Gear Manufacturer Association) up to coupling size 0090
- High power to weight ratio
- Typical application: Roll drives in the steel and paper industry, pumps, conveyors, fans and blowers

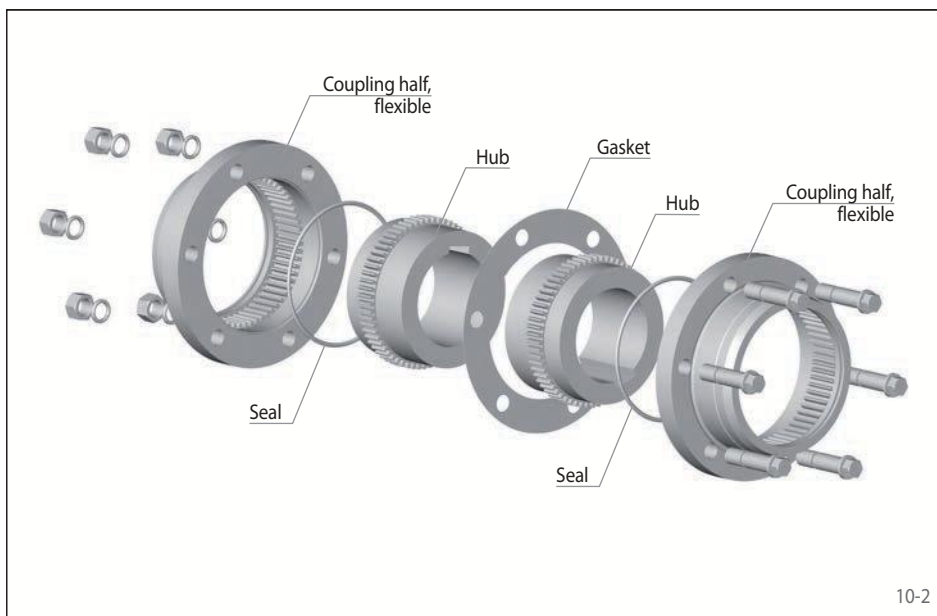

10-2

Order example

Order example	Code
Coupling design	RDZ
Coupling size	0010
Type	DTO
Material of the hub: • Steel	STA
Hub A, type: • 0, standard	0
Hub A, design: • finish bored with keyway • roughbored	FB VA
Bore diameter hub A	020
Hub B, type: • 0, standard	0
Hub B, design: • finish bored with keyway • roughbored	FB VA
Bore diameter hub B	025

RDZ 0010 DTO-STA-0FB020-0FB025

Gear Couplings RDZ ... DTO

torsionally rigid
double engagement gearing – lubricated

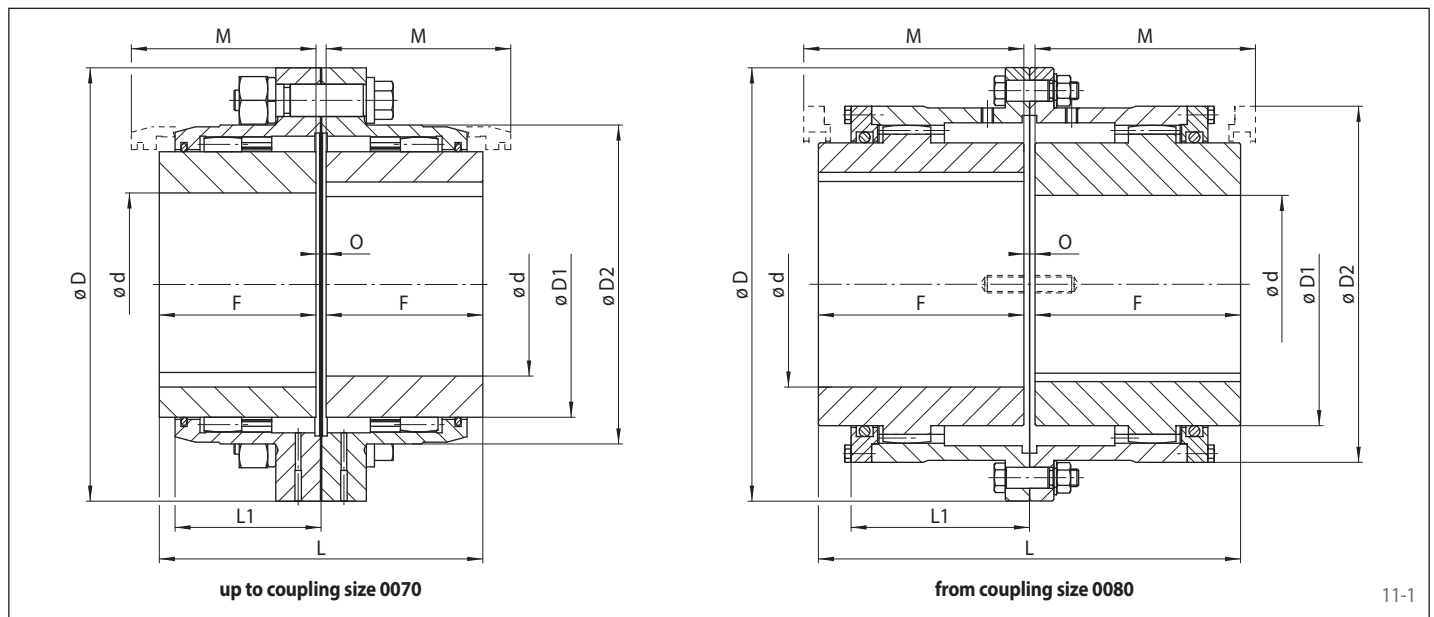

11-1

Coupling size	Nominal torque T_{KN} Nm	Nominal power at 100 min ⁻¹ P_{K100} kW	Max. speed n_{max} min ⁻¹	Moment of inertia with max. bore J_k kgm ²	Permissible misalignments		
					Axial mm	Radial mm	Angular °
0010	1330	14	8000	0,0052	±0,5	0,5	1,5
0015	2860	30	6500	0,0192	±0,5	0,8	
0020	5000	53	5600	0,0410	±0,5	1,0	
0025	10000	105	5000	0,1050	±0,5	1,2	
0030	16000	168	4400	0,1950	±0,5	1,4	
0035	22000	231	3900	0,4540	±1	1,7	
0040	32000	336	3600	0,8600	±1	2,0	
0045	45000	472	3200	1,3900	±1	2,1	
0050	62000	650	2900	2,5300	±1	2,6	
0055	84000	880	2650	3,8300	±1	2,9	
0060	115000	1205	2450	5,2100	±2	3,2	
0070	174000	1823	2150	11,0000	±2	3,7	
0080	252000	2639	1750	20,7200	±2	4,2	
0090	290000	3037	1550	34,9500	±2	4,8	
0100	391500	4100	1450	55,9500	±3	5,5	

Coupling size	Pilot bore d^* mm	Bore d^* mm		D mm	D1 mm	D2 mm	F mm	L mm	L1 mm	M** mm	O mm	Weight with max. bore kg
		min. mm	max. mm									
0010	13	15	52	116	69	84	43	89	39	51	3	4,4
0015	19	21	65	152	86	105	50	103	48	61	3	9
0020	26	28	80	178	105	127	62	127	60	76	3	15
0025	30	32	98	213	131	155	77	159	72	92	5	27
0030	36	38	115	240	152	181	91	187	84	106	5	40
0035	36	38	135	279	178	211	107	220	98	130	6	65
0040	36	38	160	318	210	250	121	248	111	145	6	96
0045	50	52	180	346	235	274	135	278	123	165	8	131
0050	69	71	195	389	254	306	153	314	141	183	8	186
0055	68	70	215	425	279	334	168	344	158	203	8	247
0060	105	110	235	457	305	366	188	384	169	228	8	299
0070	105	110	280	527	356	425	221	451	196	266	9	473
0080	105	110	285	590	385	485	249	508	243	300	10	682
0090	145	150	300	660	420	535	276	565	265	325	13	898
0100	155	160	330	711	470	595	305	623	294	355	13	1242

For finish bores, please specify bore diameter hub A and hub B. Tolerance of finish bores H7. Keyways in accordance with DIN 6885, sheet 1. Keyway tolerance JS9, different bore and keyway tolerances on request. Upon request, couplings larger than frame size 0100 also available.
* Bores also available in inch size, see page 68. ** Minimum necessary space to align the shafts.

Gear Couplings RDZ ... DFO

torsionally rigid
single engagement gearing – lubricated



12-1

Features

- High nominal torques up to 391 500 Nm
- Compensation of axial and angular misalignments
- Compact design due to inside turned hubs
- High power to weight ratio
- Typical application: Roll drives in the steel and paper industry, pumps, conveyors, fans and blowers

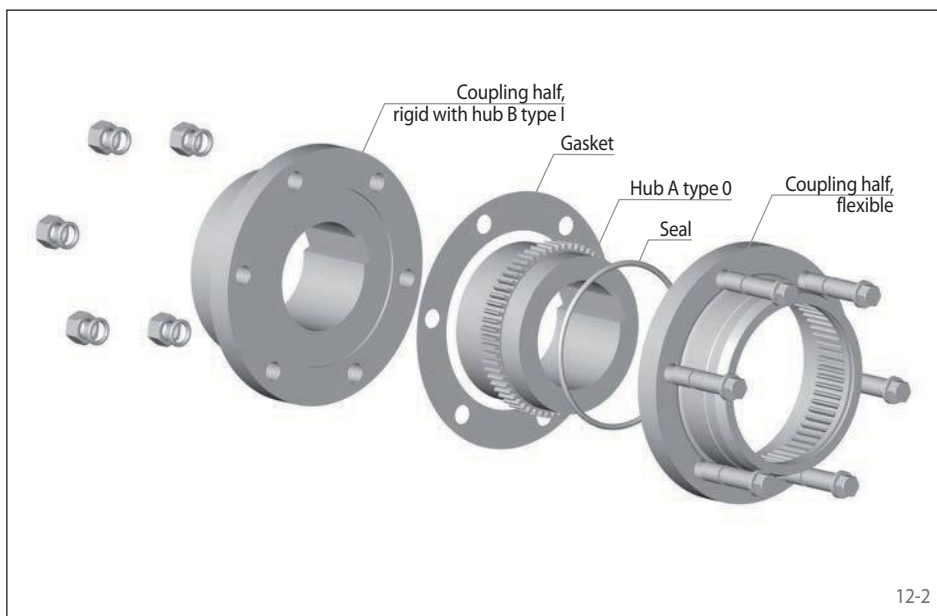

12-2

Order example

	Code
Coupling design	RDZ
Coupling size	0010
Type	DFO
Material of the hub: • Steel	STA
Hub A, type: • 0, standard	0
Hub A, design: • finish bored with keyway • roughbored	FB VA
Bore diameter hub A	020
Hub B, type: • I, coupling half, rigid with hub	1
Hub B, design: • finish bored with keyway • roughbored	FB VA
Bore diameter hub B	025

RDZ 0010 DFO-STA-0FB020-1FB025

torsionally rigid
single engagement gearing – lubricated

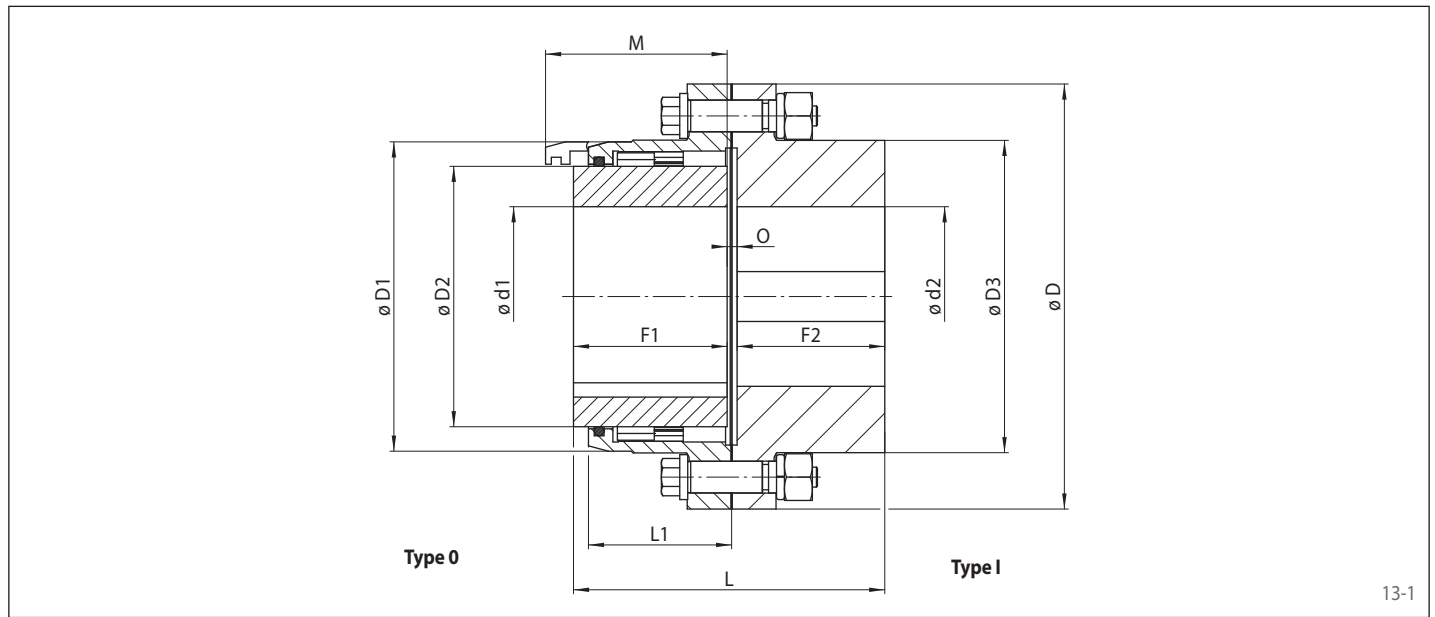

13-1

Coupling size	Nominal torque T_{KN} Nm	Nominal power at 100 min^{-1} P_{K100} kW	Max. speed n_{max} min^{-1}	Moment of inertia with max. bore J_K kgm^2	Permissible misalignments	
					Axial mm	Angular °
0010	1330	14	8000	0,0055	± 0,25	0,75
0015	2860	30	6500	0,0204	± 0,25	
0020	5000	53	5600	0,0436	± 0,25	
0025	10000	105	5000	0,1110	± 0,25	
0030	16000	168	4400	0,2100	± 0,25	
0035	22000	231	3900	0,4770	± 0,5	
0040	32000	336	3600	0,9200	± 0,5	
0045	45000	472	3200	1,4680	± 0,5	
0050	62000	650	2900	2,7300	± 0,5	
0055	84000	880	2650	4,2000	± 0,5	
0060	115000	1205	2450	5,7000	± 1	
0070	174000	1823	2150	12,0500	± 1	
0080	252000	2639	1750	21,7700	± 1	
0090	290000	3037	1550	36,6000	± 1	
0100	391500	4100	1450	56,2700	± 1,5	

Coupling size	Pilot bore d^* mm	Min. bore d^* mm	Max. bore d^*		D mm	D1 mm	D2 mm	D3 mm	F1 mm	F2 mm	L mm	L1 mm	M** mm	O mm	Weight with max. bore kg
			Hub type 0 mm	Hub type I mm											
0010	13	15	52	60	116	84	69	84	43	40	87	39	51	4	4,5
0015	19	21	65	80	152	105	86	107	50	47	101	48	61	4	9,5
0020	26	28	80	90	178	127	105	130	62	59	125	60	76	4	15,5
0025	30	32	98	110	213	155	131	157	77	74	156	72	92	5	27,5
0030	36	38	115	130	240	181	152	182	91	88	184	84	106	5	41,5
0035	36	38	135	150	279	211	178	212	107	102	215	98	130	6	67,0
0040	36	38	160	180	318	250	210	250	121	116	245	111	145	8	100,0
0045	50	52	180	200	346	274	235	276	135	131	274	123	165	8	135,0
0050	69	71	195	220	389	306	254	309	153	148	310	141	183	9	195,0
0055	68	70	215	240	425	334	279	334	168	173	350	158	203	9	261,0
0060	105	110	235	260	457	366	305	366	188	185	384	169	228	10	316,0
0070	105	110	280	300	527	425	356	425	221	218	452	196	266	13	500,0
0080	105	110	285	335	590	485	385	470	249	249	511	243	300	13	715,0
0090	145	150	300	370	660	535	420	518	276	276	567	265	325	15	969,0
0100	155	160	330	405	711	595	470	572	305	305	626	294	355	16	1259,0

For finish bores, please specify bore diameter hub A and hub B. Tolerance of finish bores H7. Keyways in accordance with DIN 6885, sheet 1. Keyway tolerance J59, different bore and keyway tolerances on request.

* Bores also available in inch size, see page 68. ** Minimum necessary space to align the shafts.

Gear Couplings RDZ ... EEO

torsionally rigid
continuous sleeve and double engagement gearing

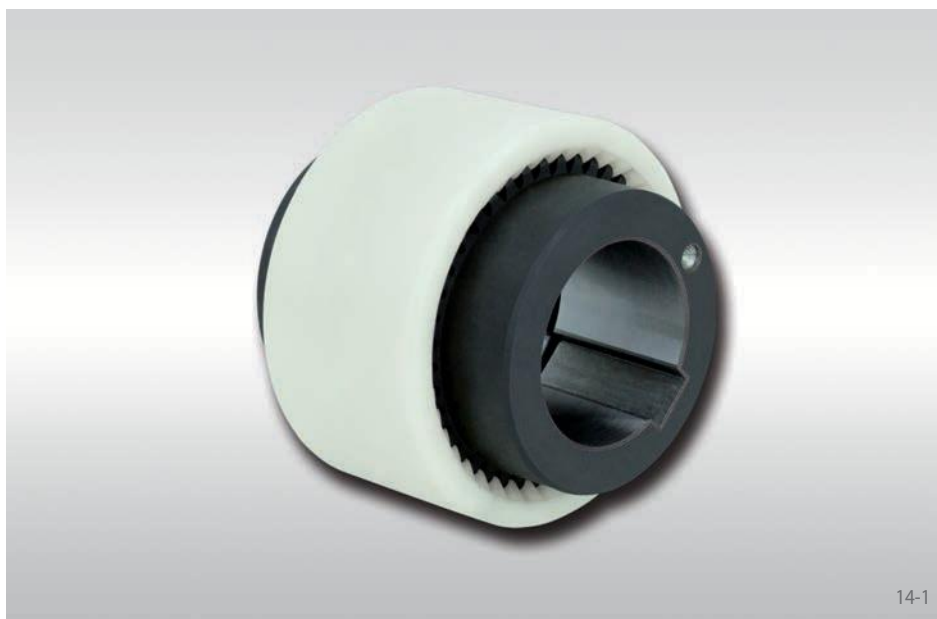

Features

- Compensation of axial, radial and angular misalignments
- Double engagement allows smooth torque transmission
- Deployable in horizontal and vertical applications
- Temperature range from -25 °C to +100 °C
- Low weight and low moments of inertia
- Maintenance free thanks to a combination of steel and polyamide 6.6
- Typical applications: Hydraulics, pump drives

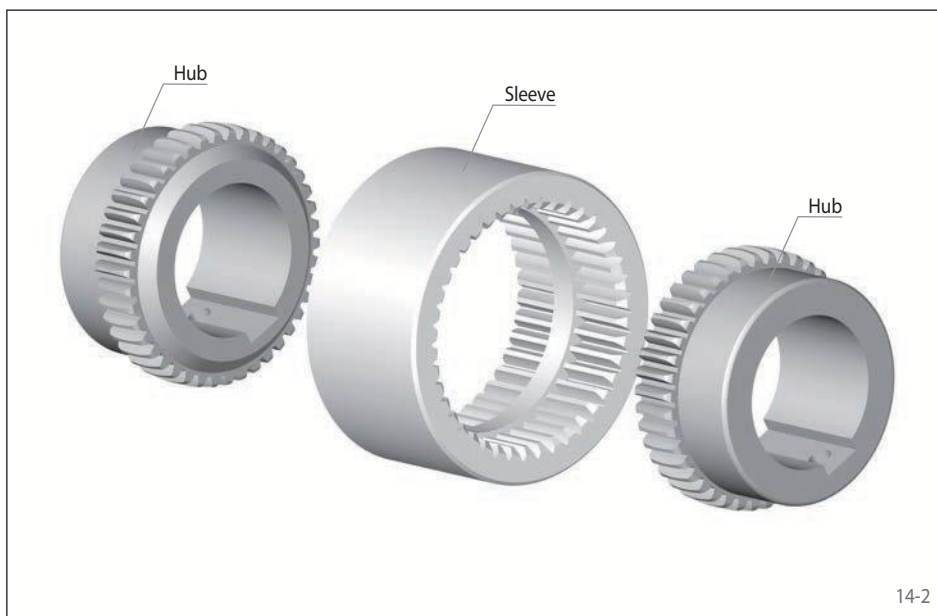

Order example

	Code
Coupling design	RDZ
Coupling size	0014
Type	EEO
Material of the hub: • Steel	STA
Hub A, type: • 0, standard	0
Hub A, design: • finish bored with keyway • roughbored	FB VA
Bore diameter hub A	015
Hub B, type: • 0, standard	0
Hub B, design: • finish bored with keyway • roughbored	FB VA
Bore diameter hub B	015
Material of the sleeve: • Polyamide 6.6	PA66

RDZ 0014 EEO-STA-0FB015-0FB015-PA66

torsionally rigid
continuous sleeve and double engagement gearing

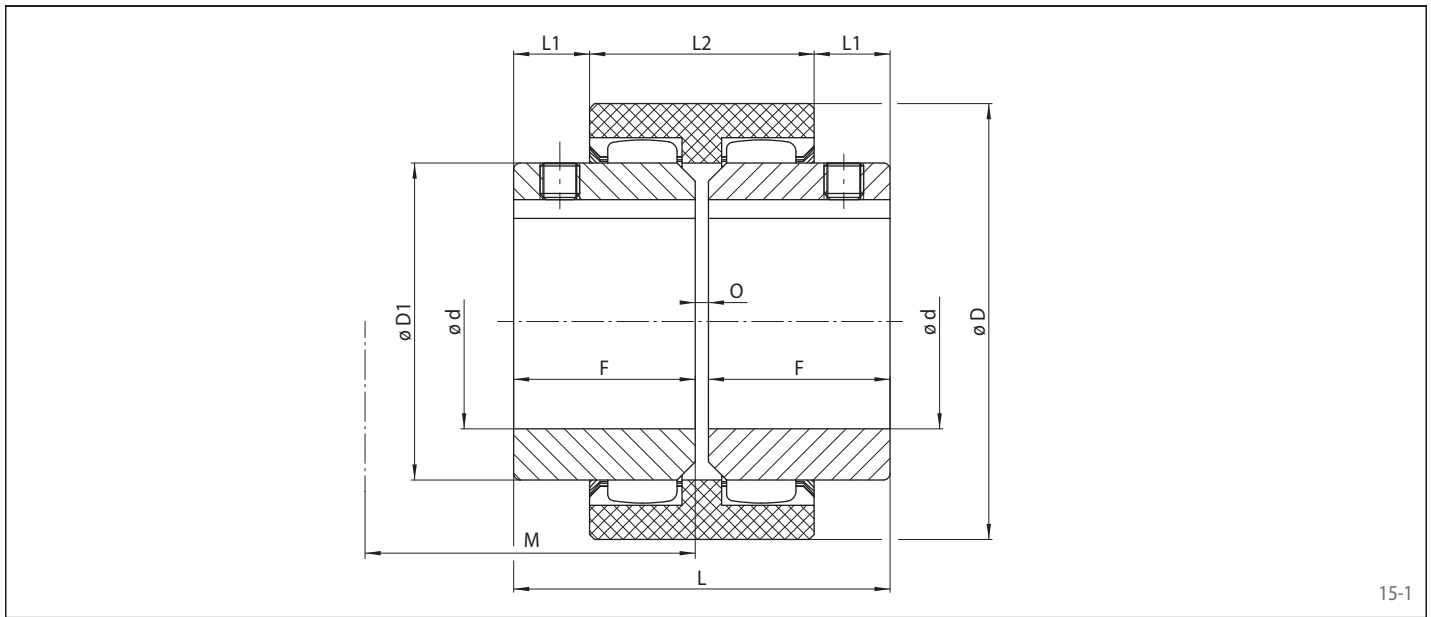

15-1

Coupling size	Nominal torque T_{KN} Nm	Nominal power at 100 min^{-1} P_{K100} kW	Max. speed n_{max} min^{-1}	Moment of inertia with max. bore J_k kgcm ²	Permissible misalignments		
					Axial +/- mm	Radial mm	Angular °
0014	10	0,10	14000	0,26	1	0,3	1
0019	16	0,17	11800	0,47		0,3	
0024	20	0,21	10600	0,93		0,4	
0028	45	0,47	8500	3,09		0,4	
0032	60	0,63	7500	5,48		0,4	
0038	80	0,84	6700	8,68		0,4	
0042	100	1,00	6000	14,28		0,4	
0048	140	1,50	5600	18,34		0,4	
0065	380	4,00	4000	84,80		0,4	

Coupling size	Pilot bore d^* mm	Bore d^*		D mm	D1 mm	F mm	L mm	L1 mm	L2 mm	M** mm	O mm	Weight with max. bore kg
		min. mm	max. mm									
0014	5	6	15	40	25	23	50	6,5	37	37	4	0,10
0019	10	11	20	48	32	25	54	8,5	37	37	4	0,23
0024	10	11	24	52	36	26	56	7,5	41	41	4	0,32
0028	10	11	28	66	44	40	84	19	46	46	4	0,74
0032	10	11	32	76	50	40	84	18	48	48	4	0,95
0038	10	11	38	83	58	40	84	18	48	48	4	1,23
0042	10	11	42	92	65	42	88	19	50	50	4	1,50
0048	10	11	48	95	68	50	104	27	50	50	4	1,81
0065	10	11	65	132	96	55	114	23	68	68	4	4,35

For finish bores, please specify bore diameter hub A and hub B. Tolerance of finish bores H7. Keyways in accordance with DIN 6885, sheet 1. Keyway tolerance JS9.

* Bores also available in inch size, see page 68.

** Minimum dimensions by which the units need to be pushed apart to enable a radial disassembly of the sleeve.

Selection of IEC standard motors

Frame size	A.C. motor 50 Hz		Motor power n = 3 000 min ⁻¹ 2 pole		RDZ ... EEO Coupling size	Motor power n = 1 500 min ⁻¹ 4 pole		RDZ ... EEO Coupling size	Motor power n = 1 000 min ⁻¹ 6 pole		RDZ ... EEO Coupling size	Motor power n = 750 min ⁻¹ 8 pole		RDZ ... EEO Coupling size		
	Shaft end d x l		Power P _{AN} kW	Torque T _{AN} Nm		Power P _{AN} kW	Torque T _{AN} Nm		Power P _{AN} kW	Torque T _{AN} Nm		Power P _{AN} kW	Torque T _{AN} Nm		Power P _{AN} kW	Torque T _{AN} Nm
	2 pole	4, 6, 8 pole														
56	9 x 20		0,09 0,12	0,32 0,41	0014	0,06 0,09	0,43 0,64	0014	0,037 0,045	0,43 0,52	0014	-	-	-		
63	11 x 23		0,18 0,25	0,62 0,86		0,12 0,18	0,88 1,3		0,06 0,09	0,7 1,1		-	-	-		
71	14 x 30		0,37 0,55	1,3 1,9		0,25 0,37	1,8 2,5		0,18 0,25	2 2,8		0,09 0,12	1,4 1,8	0014		
80	19 x 40		0,75 1,1	2,5 3,7	0019	0,55 0,75	3,7 5,1	0,37 0,55	3,9 5,8	0019	0,18 0,25	2,5 3,5	0019			
90S	24 x 50		1,5	5	0024	1,1	7,5	0,75	8	0024	0,37	5,3	0024			
90L			2,2	7,4		1,5	10	1,1	12		0,55	7,9				
100L	28 x 60		3	9,8	0028	2,2 3	15 20	1,5	15	0028	0,75 1,1	11 16	0028			
112M			4	13		4	27	2,2	22		1,5	21				
132S	38 x 80		5,5 7,5	18 25	0038	5,5	36	3	30	0038	2,2	30	0038			
132M			-	-		7,5	49	4 5,5	40 55		3	40				
160M	42 x 110		11 15	36 49	0042	11	72	7,5	75	0042	4 5,5	54 74	0042			
160L			18,5	60		15	98	11	109		7,5	100				
180M	48 x 110		22	71	0048	18,5	121	-	-	0048	-	-	0048			
180L			-	-		22	144	15	148		11	145				
200L	55 x 110		30 37	97 120	0065	30	196	18,5 22	181 215	0065	15	198	0065			
225S	55 x 110	60 x 140	-	-		37	240	-	-		18,5	244				
225M			45	140		45	292	30	293		22	290				
250M	60 x 140	65 x 140	55	177		55	356	37	361		30	392				
280S	65 x 140	75 x 140	75	241		75	484	45	438		37	483				
280M			90	289		90	581	55	535		45	587				
315S	65 x 140	80 x 170	110	353		110	707	-	75		727	-		55	712	-
315M			132	423	132	849	90	873	75	971						
315L			160 200	513 641	160 200	1030 1290	110 132	1070 1280	90 110	90 110						

During selection, the nominal torque of the coupling at +30 °C was factored in with a start-up factor SZ of 1 and a co-efficient of impact SA/SL of 1. Detailed selection in accordance with the technical information on page 64 et seq.

Standard bores

Coupling size	Bore d								
	mm	mm	mm	mm	mm	mm	mm	mm	mm
0014	9	11	14	15	-	-	-	-	-
0019	11	14	15	18	19	20	-	-	-
0024	11	14	15	18	19	20	22	24	-
0028	14	15	18	19	20	22	24	28	-
0032	18	19	20	22	24	28	32	-	-
0038	18	19	20	22	24	28	32	38	-
0042	18	19	20	22	24	28	32	38	42
0048	28	32	38	42	48	-	-	-	-
0065	32	38	42	48	55	60	65	-	-

torsionally rigid
single disc pack



18-1

Features

- Nominal torques up to 18 700 Nm
- Combines high torque capacity with low weight
- Backlash free
- Compensation of axial and angular misalignments
- High torsional rigidity with low axial rigidity
- Temperature range -20 °C to +280 °C
- Maintenance free and long life with proper alignment
- Typical application: Pumps, fans, packaging machines, paper machines, printing machines, conveyor systems, dynamometers, gantry systems

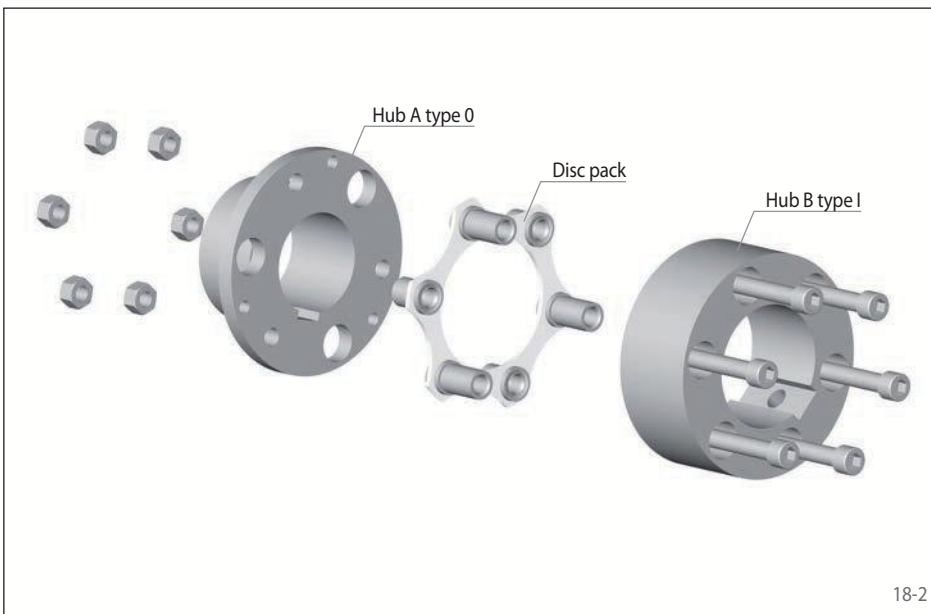

18-2

Order example

Order example	Code
Coupling design	RDL
Coupling size	0038
Type	DSO
Material of the hub: • Steel	STA
Hub A, type: • 0, standard • I, increased max. bore	0 1
Hub A, design: • finish bored with keyway • roughbored	FB VA
Bore diameter hub A	025
Hub B, type: • 0, standard • I, increased max. bore	0 1
Hub B, design: • finish bored with keyway • roughbored	FB VA
Bore diameter hub B	030

RDL 0038 DSO-STA-0FB025-1FB030

torsionally rigid
single disc pack

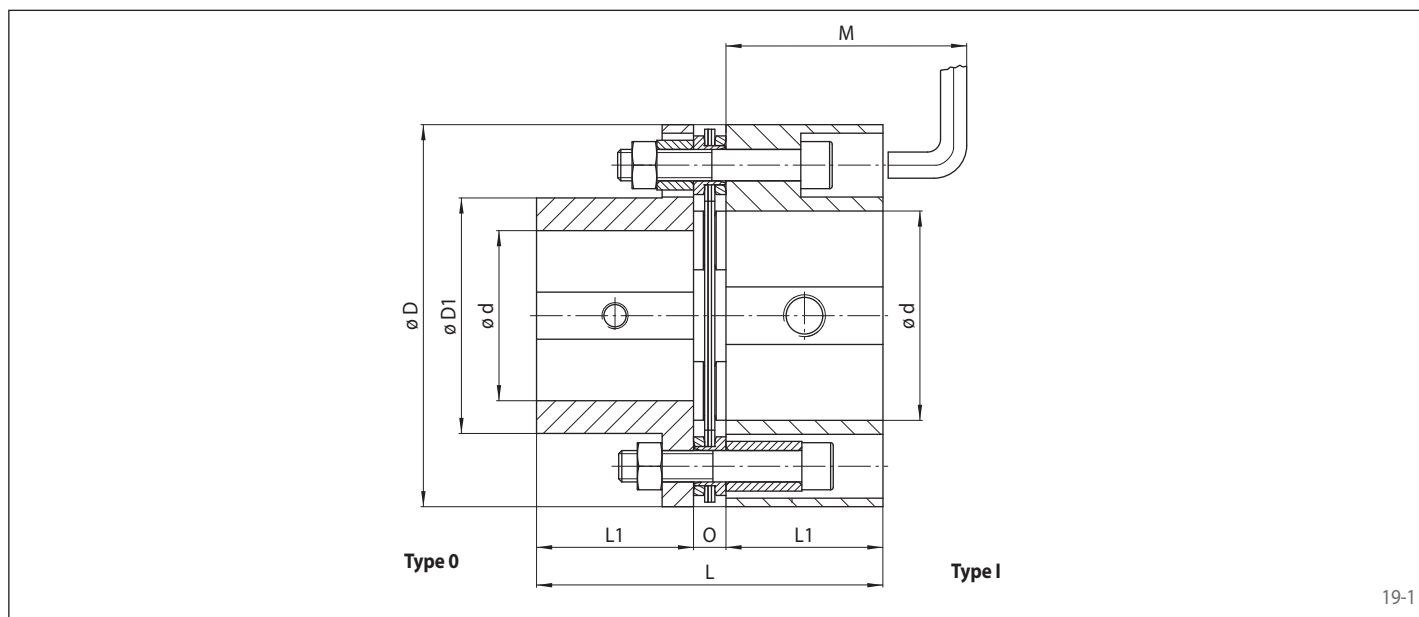

19-1

Coupling size	Nominal torque T_{KN} Nm	Nominal power at 100 min^{-1} P_{K100} kW	Max. speed n_{\max} min^{-1}	Torsional stiffness C_T MNm/rad	Moment of inertia J_K kgm^2	Permissible misalignments		
						Axial mm	Radial mm	Angular $^\circ$
0024	96	1,0	7500	0,041	0,00047	±1	Due to design, no radial misalignments are permissible.	0,75
0038	232	2,4	7000	0,093	0,00170			
0048	620	6,5	6000	0,248	0,00820			
0065	1200	12,6	5200	0,529	0,01430			
0075	1910	20,0	4800	0,895	0,02630			
0100	3460	36,3	4400	1,665	0,06400			
0110	5600	58,5	4200	2,393	0,13200			
0125	7100	74,2	4000	3,490	0,32110			
0140	10400	108,7	3800	on demand	0,39450			
0150	14500	152,2	3700		0,63500			
0160	18700	196,0	3600		1,00500	±2		

Torsional stiffness and moment of inertia refer to a combination of hub type 0 and hub type I with max. possible bore diameter respectively.

Coupling size	Pilot bore d^* mm	Min. bore d^* mm	Max. bore d^*		D mm	D1 mm	L mm	L1 mm	M** mm	Gap O mm	Weight kg
			Hub type 0 mm	Hub type I mm							
0024	8	10	22	25	63	35	66,5	30	75	6,5	0,9
0038	10	12	30	38	82	45	86,5	40	85	6,5	1,8
0048	15	17	40	50	102	57	98,0	45	95	8,0	3,2
0065	15	17	52	70	128	77	119,5	55	110	9,5	5,8
0075	20	22	65	80	146	94	132,0	60	120	12,0	8,5
0100	25	27	80	100	176	115	153,0	70	140	13,0	14,0
0110	30	32	90	115	197	132	194,5	90	175	14,4	22,2
0125	40	42	105	130	225	147	206,1	95	185	16,2	30,5
0140	45	47	115	140	250	162	229,4	105	195	19,5	42,7
0150	50	52	120	155	275	178	251,5	115	215	21,5	57,3
0160	60	62	135	165	300	190	283,6	130	235	23,5	76,1

For finish bores, please specify bore diameter hub A and hub B. Tolerance of finish bores H7. Keyways in accordance with DIN 6885, sheet 1. Keyway tolerance J59, different bore and keyway tolerances on request.

The weight refers to a combination of hub type 0 and hub type I with max. possible bore diameter respectively.

In deviation from figure 19-1, the combination of the hub type 0 / 0 and type I / I is possible.

Upon request, also available with taper bushes.

Upon request, couplings larger than frame size 0160 also available.

For vertical installation, please contact RINGSPANN.

* Bores also available in inch size, see page 68.

** Distance M is required to tighten and loosen the screws for hub type I.

Disc Couplings RDL ... DSZ

torsionally rigid
double disc packs with spacer



Features

- Nominal torques up to 18700 Nm
- Combines high torque capacity with low weight
- Backlash free
- Compensation of axial, radial and angular misalignments
- Double disc pack allows smooth torque transmission
- High torsional rigidity with low axial rigidity
- Temperature range -20 °C to +280 °C
- Maintenance free and long life with proper alignment
- Typical application: Pumps, fans, packaging machines, paper machines, printing machines, mixers, dynamometers

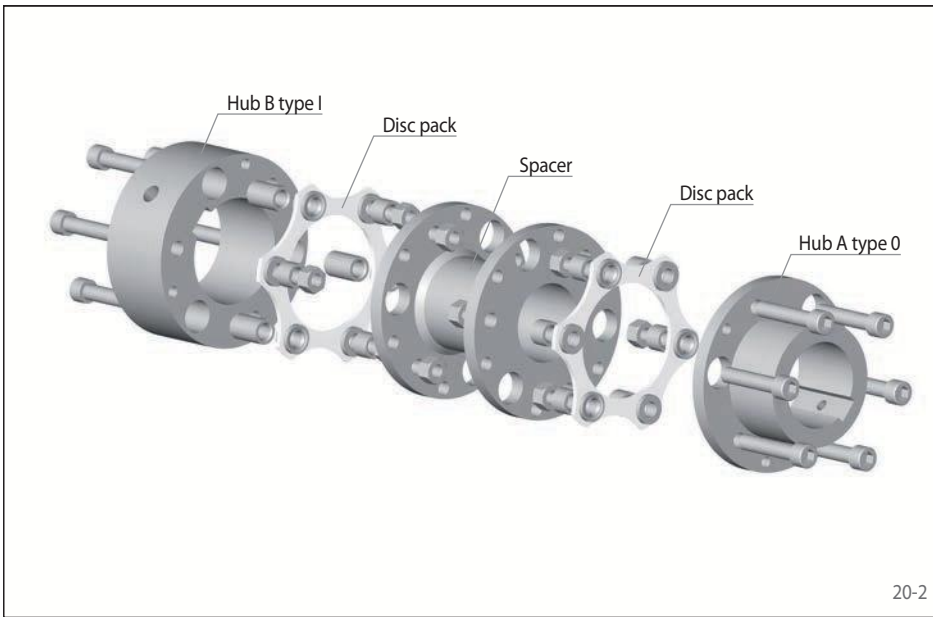

Order example

Coupling design	RDL
Coupling size	0024
Type	DSZ
Material of the hub: • Steel	STA
Hub A, type: • 0, standard • I, increased max. bore	0 1
Hub A, design: • finish bored with keyway • roughbored	FB VA
Bore diameter hub A	020
Hub B, type: • 0, standard • I, increased max. bore	0 1
Hub B, design: • finish bored with keyway • roughbored	FB VA
Bore diameter hub B	022
DBSE L3	0100
↓	
RDL 0024 DSZ-STA-0FB020-1FB022-0000-0100	

torsionally rigid
double disc packs with spacer

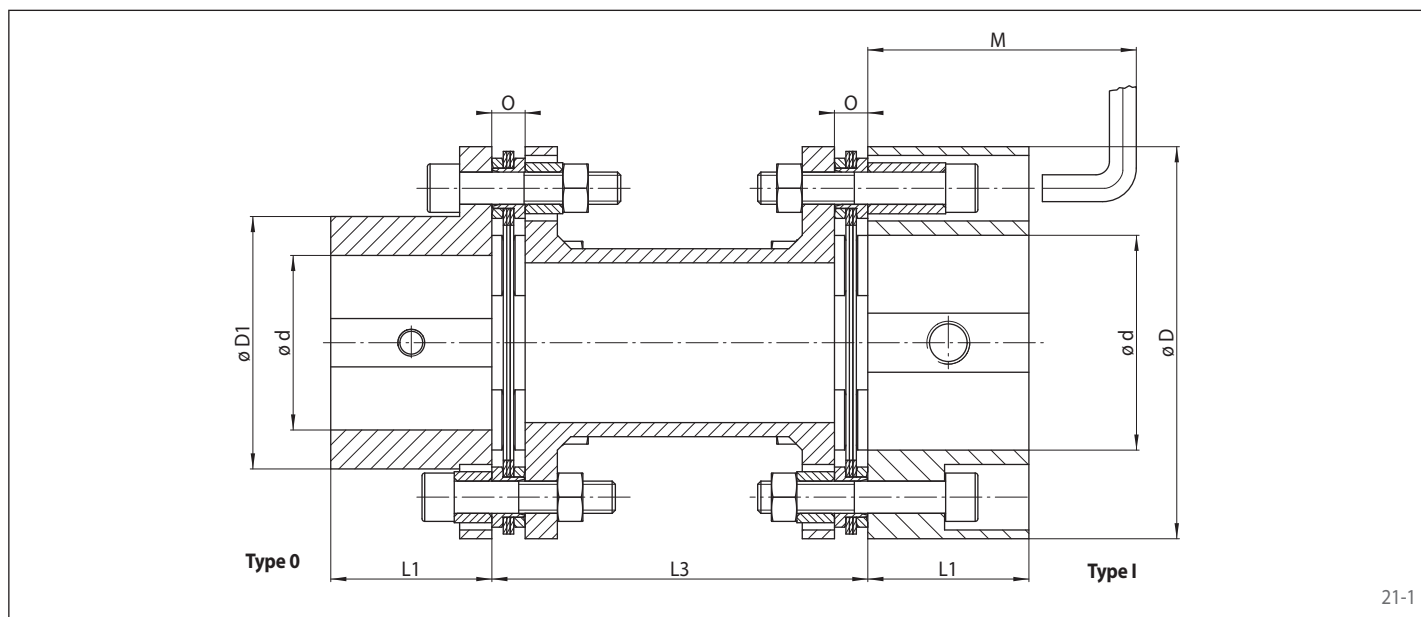

21-1

Coupling size	Nominal torque T_{KN} Nm	Nominal power at 100 min^{-1} P_{K100} kW	Max. speed n_{max} min^{-1}	Torsional stiffness C_T MNm/rad	Moment of inertia J_k with DBSE L3		Permissible misalignments		
					with shortest standard kgm ²	per additional meter to the standard kgm ²	Axial mm	Radial mm	Angular °
0024	96	1,0	7500	0,021	0,0006	0,0004	±1	0,013	1,5
0038	232	2,4	7000	0,047	0,0021	0,0011			
0048	620	6,5	6000	0,100	0,0062	0,0017			
0065	1200	12,6	5200	0,222	0,0180	0,0047			
0075	1910	20,0	4800	0,381	0,0350	0,0088			
0100	3460	36,3	4400	0,773	0,0850	0,0210			
0110	5600	58,5	4200	0,962	0,1678	0,0560			
0125	7100	74,2	4000	1,529	0,3098	0,0560			
0140	10400	108,7	3800	1,892	0,5328	0,0670			
0150	14500	152,2	3700	2,454	0,8610	0,1670			
0160	18700	196,0	3600	3,783	1,3580	0,1670	±2		

Torsional stiffness and moment of inertia refer to a combination of hub type 0 and hub type I with max. possible bore diameter respectively and shortest standard DBSE L3.

Coupling size	Pilot bore d^* mm	Min. bore d^* mm	Max. bore d^*		D mm	D1 mm	L1 mm	DBSE L3		M** mm	Gap O mm	Weight with DBSE L3	
			Hub type 0 mm	Hub type I mm				shortest possible mm	Standard mm			with shortest standard kg	per additional meter to the standard kg
0024	8	10	22	25	63	35	30	54	100 140	75	6,5	1,3	2,3
0038	10	12	30	38	82	45	40	54	100 140 180	85	6,5	2,3	3,2
0048	15	17	40	50	102	57	45	66		95	8,0	4,7	3,2
0065	15	17	52	70	128	77	55	78	110	9,5	8,0	7,0	
0075	20	22	65	80	146	94	60	88	140 180	120	12,0	11,4	8,4
0100	25	27	80	100	176	115	70	102	140 180 250	140	13,0	19,5	13,1
0110	30	32	90	115	197	132	90	114		175	14,4	29,3	21,7
0125	40	42	105	130	225	147	95	132	185	16,2	42,1	21,7	
0140	45	47	115	140	250	162	105	144	180 250 300	195	19,5	61,0	27,1
0150	50	52	120	155	275	178	115	168		215	21,5	81,7	42,8
0160	60	62	135	165	300	190	130	170	235	23,5	106,9	42,8	

For finish bores, please specify bore diameter hub A and hub B. Tolerance of finish bores H7. Keyways in accordance with DIN 6885, sheet 1. Keyway tolerance JS9, different bore and keyway tolerances on request. • The weight refers to the shortest standard DBSE L3.

Upon request: Varying DBSEs L3; Designs with taper bushes; Couplings larger than frame size 0160

In deviation from figure 21-1, a combination of the hubs of type 0 / 0 and type I / I is possible.

For vertical installation, please contact RINGSPANN.

* Bores also available in inch size, see page 68. • ** Distance M is required to tighten and loosen the screws for hub type I.

torsionally rigid
double disc packs, design according to API 610



22-1

Features

- Nominal torques up to 18700 Nm
- Combines high torque capacity with low weight
- Backlash free
- Compensation of axial, radial and angular misalignments
- Double disc pack allows smooth torque transmission
- High torsional rigidity with low axial rigidity
- Temperature range -20 °C to +280 °C
- Typical application: Centrifugal pumps, screw pumps, turbo compressors, rotary piston fans

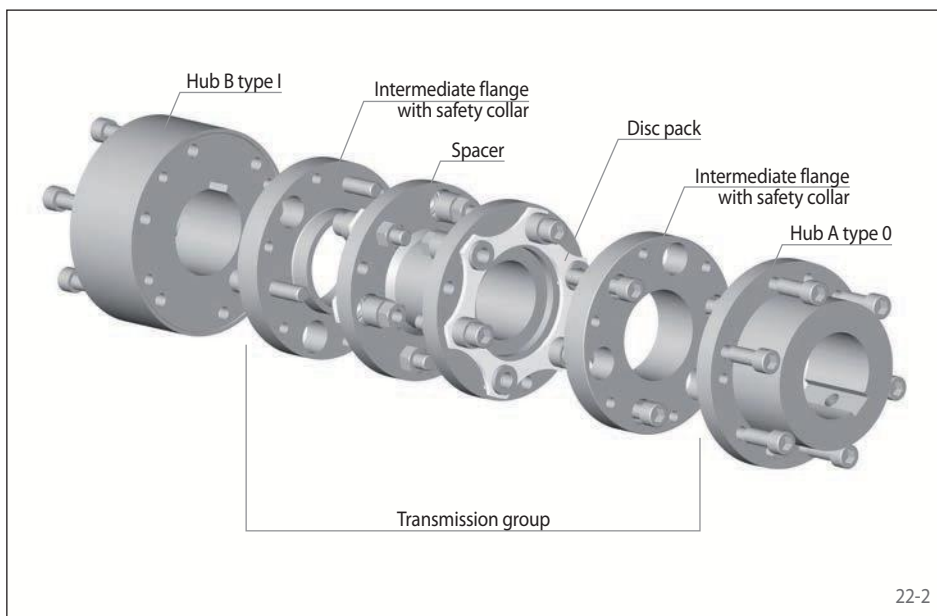

22-2

Additional features

- No wear with optimal alignment, no lubrication necessary
- Corresponds to the provisions in accordance with API 610 and optionally, upon request, with the requirements in accordance with API 671

Order example

Order example	Code
Coupling design	RDL
Coupling size	0048
Type	DSA
Material of the hub:	STA
• Steel	
Hub A, type:	
• 0, standard	0
• I, increased max. bore; pitch diameter Ta	1
• II, extended	2
• III, extended, increased max. bore; pitch diameter Tb	3
Hub A, design:	
• finish bored with keyway	FB
• roughbored	VA
Bore diameter hub A	045
Hub B, type:	
• 0, standard	0
• I, increased max. bore; pitch diameter Ta	1
• II, extended	2
• III, extended, increased max. bore; pitch diameter Tb	3
Hub B, design:	
• finish bored with keyway	FB
• roughbored	VA
Bore diameter hub B	060
DBSE L3	0180

RDL 0048 DSA-STA-0FB045-1FB060-0000-0180

torsionally rigid
double disc packs, design according to API 610

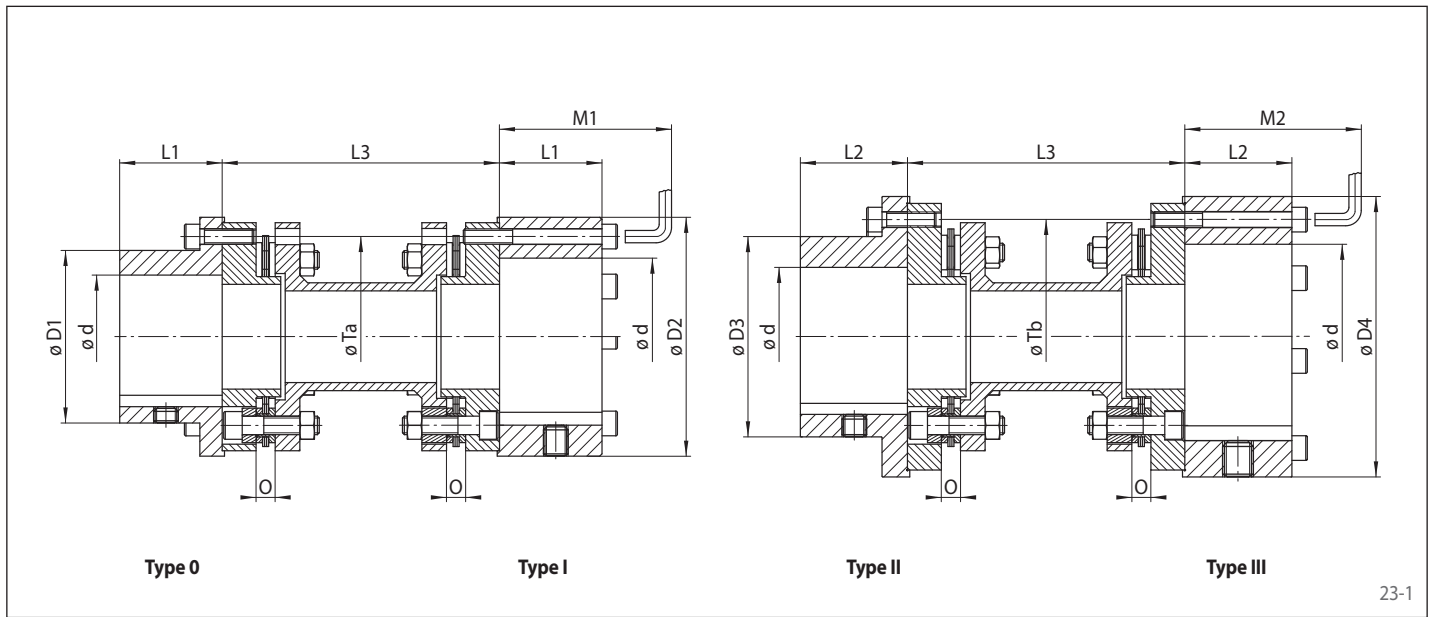

23-1

Coupling size	Nominal torque T_{KN} Nm	Nominal power at 100 min^{-1} P_{K100} kW	Max. speed* n_{max} min^{-1}	Torsional stiffness C_T MNm/rad	Moment of inertia J_k with DBSE L3		Permissible misalignments		
					with shortest standard kgm ²	per additional meter to the standard kgm ²	Axial mm	Radial mm	Angular °
0024	96	1,0	7500	0,018	0,0012	0,0002	±1	0,013	1,5
0038	232	2,4	7000	0,043	0,0039	0,0006			
0048	620	6,5	6000	0,100	0,0094	0,0011			
0065	1200	12,6	5200	0,232	0,0283	0,0034			
0075	1910	20,0	4800	0,395	0,0604	0,0088			
0100	3460	36,3	4400	0,749	0,1410	0,0213			
0110	5600	58,5	4200	1,239	0,3650	0,0561			
0125	7100	74,2	4000	1,649	0,4181	0,0561			
0140	10400	108,7	3800	2,179	0,7067	0,0670			
0150	14500	152,2	3700	3,350	1,1340	0,1666			
0160	18700	196,0	3600	4,271	1,7740	0,1666	±2		

Torsional stiffness and moment of inertia refer to a combination of hub type 0 and hub type I with max. possible bore diameter respectively and shortest standard DBSE L3.
* Higher speeds on request.

Coupling size	Pilot bore d^* mm	Min. bore d^*		Max. bore d^*				D1	D2	D3	D4	L1	L2	DBSE L3		M1**	M2**	Gap O	Weight with DBSE L3	
		Hub type 0 + I mm	Hub type II + III mm	Hub type 0 mm	Hub type I mm	Hub type II mm	Hub type III mm							shortest possible mm	Standard mm				with shortest standard kg	per additional meter to the standard kg
0024	6	8	10	24	42	38	48	40	69	55	90	30	40	80	100	80	90	7,5	2	1,32
0038	8	10	15	38	48	48	72	55	90	70	108	40	45	89	140	90	105	7,5	4	2,29
0048	13	15	20	48	72	65	92	70	108	86	135	45	55	103	180	105	120	8,5	9	3,19
0065	18	20	25	65	92	80	102	86	135	108	152	55	60	128	140	120	125	9,2	16	4,47
0075	23	25	30	80	102	90	120	108	152	130	182	60	70	148	180	125	135	12,4	22	8,38
0100	28	30	45	90	120	108	140	130	182	158	197	70	90	161	250	135	155	10,6	33	13,08
0110	43	45	55	108	140	127	155	158	197	181	225	90	95	175	180	155	160	13,9	49	21,72
0125	53	55	65	127	155	140	178	181	225	206	250	95	105	180	250	160	170	14,5	61	21,72
0140	63	65	70	140	178	155	192	206	250	223	275	105	115	194		170	190	15,9	83	27,06
0150	68	70	75	155	192	170	212	223	275	248	300	115	130	213	250	190	215	17,4	105	42,79
0160	73	75	80	170	212	190	255	248	300	280	375	130	145	225		215	245	18,3	136	42,79

For finish bores, please specify bore diameter hub A and hub B. Tolerance of finish bores H7. Keyways in accordance with DIN 6885, sheet 1. Keyway tolerance JS9, different bore and keyway tolerances on request.

The weight refers to a combination of hub type 0 and hub type I with max. possible bore diameter respectively and shortest standard DBSE L3.
When ordering please specify hub type. Possible hub combinations: Type 0 / 0; 0 / I; I / I; II / II; II / III or III / III; Pitch diameter T_a and T_b are not identical
Upon request: Varying DBSEs L3; Design in accordance with ATEX 2014/34/EU; Designs with taper bushes; Couplings larger than frame size 0160
For vertical installation, please contact RINGSPANN.

* Bores also available in inch size, see page 68. ** Distance M1 and M2 is required to tighten and loosen the screws for hub type I and type III.

Design RDA ... ESO-...-0... Hub with keyway

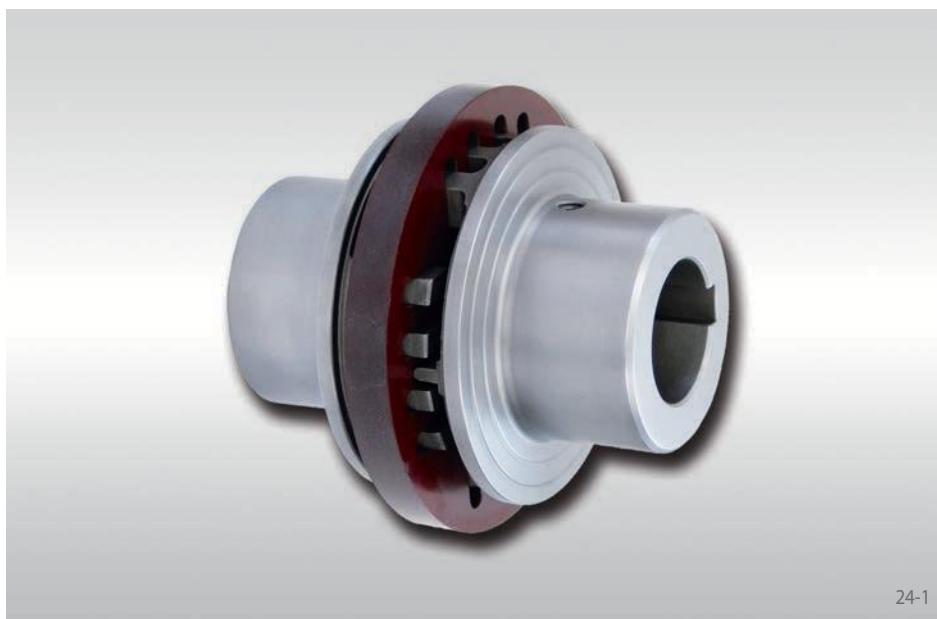

24-1

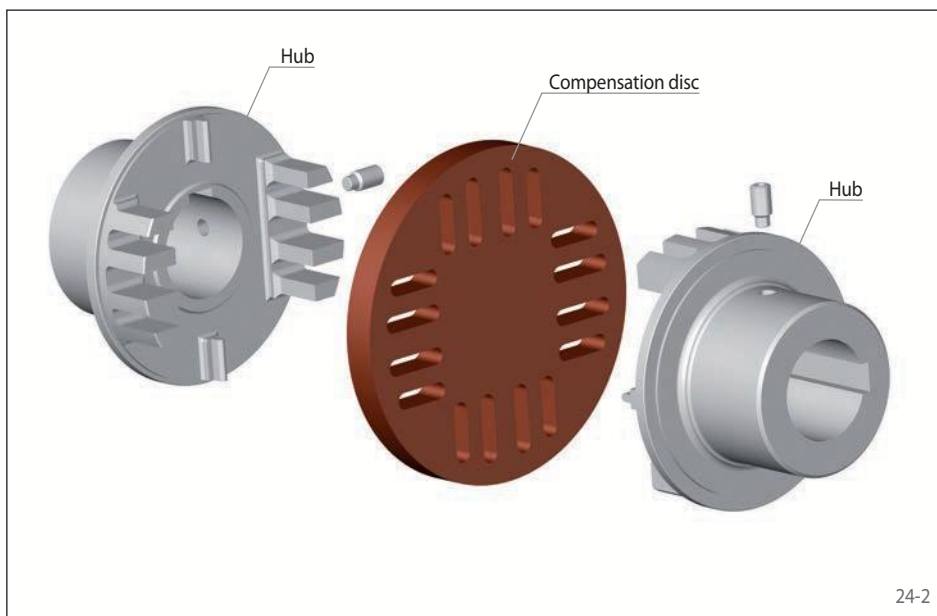

24-2

Features

- Compact design
- Simple robust design
- Electrical insulation
- No stick-slip effect
- Large radial shaft misalignment permissible
- Torsionally rigid
- Minimal restoring forces to adjacent machine parts
- Typical applications: Printing machines, machine tools

Order example

	Code
Coupling design	RDA
Coupling size	0010
Type	ESO
Material of the hub:	
• Steel	STA
• Nodular cast iron	GJS
Hub A, type:	0
• 0, standard	
Hub A, design:	
• finish bored with keyway	FB
• roughbored	VA
Bore diameter hub A	010
Hub B, type:	0
• 0, standard	
Hub B, design:	
• finish bored with keyway	FB
• roughbored	VA
Bore diameter hub B	015
Material of the compensation disc:	
• HGW 2082 in accordance with DIN 7735	HG82

RDA 0010 ESO-GJS-0FB010-0FB015-HG82

Design RDA ... ESO-...-0...

Hub with keyway

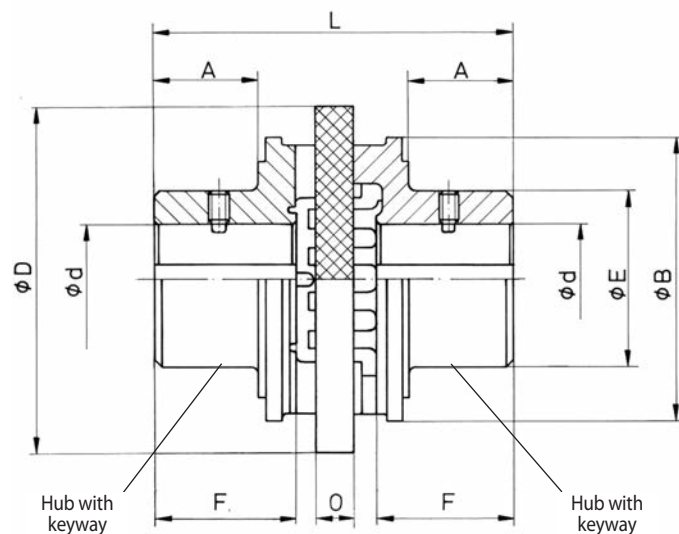

25-1

Coupling size	Material of the hub		Max. torque T_{Kmax} Nm	Max. speed n_{max} min ⁻¹	Moment of inertia J_K kgm ²	Max. misalignments*		Pilot bore d mm	Finish bore d		A mm	B mm	D mm	E mm	F** mm	L mm	O mm	Weight with rough bore kg
	Steel STA	Nodular cast iron GJS				Axial +/- mm	Radial mm		min. mm	max. mm								
0010	x	-	2	13000	0,0001	0,75	0,50	4,3	5	15	-	-	32	26	13	35	6	0,10
0012	x	-	4	10500	0,0002	0,75	0,60	5	6	18	-	-	40	32	16	42	4	0,20
0016	x	-	8	8400	0,0003	0,75	0,80	7	8	25	-	-	50	40	18,5	51	6	0,38
0020	x	-	16	6800	0,0004	1,00	1,00	9	10	30	-	-	63	50	25	64	6	0,78
0027	x	-	32	5350	0,0008	1,25	1,35	11	12	40	-	-	80	65	32	85	8	1,70
0035	-	x	85	4100	0,0013	1,50	1,75	15	16	35	33	90	110	53	42	112	12	1,90
0042	-	x	190	3400	0,0039	1,50	2,10	19	20	42	41	110	135	66	53	136	14	3,70
0050	-	x	500	2670	0,0097	2,00	2,50	29	30	50	51	135	160	85	62	159	16	6,30
0070	-	x	1000	2140	0,0268	2,00	3,50	33	34	70	65	163	200	104	79	200	20	12,10
0090	-	x	2000	1700	0,1110	2,50	4,50	48	50	90	81	202	250	150	100	247	25	28,90
0110	-	x	4000	1350	0,2911	4,00	5,50	58	60	110	101	254	315	175	124	312	32	50,90
0140	-	x	8000	1050	0,9767	4,50	7,00	72	75	140	130	330	400	216	160	402	40	104,00

For finish bores, please specify bore diameter hub A and hub B. Tolerance of finish bores H7. Keyways in accordance with DIN 6885, sheet 1. Keyway tolerance P9.

* max. angular displacement 3°.

**The hub length F can be shortened, which would change the dimensions A, C and L accordingly.

Elastomer element	Material	Temperature range °C	Colour
HGW 2082	Cotton fabric-phenolic	up to +100	red

Flexible Couplings RDA ... ESO

Design RDA ... ESO-STA-1KA ...

Hub with backlash free clamping connection



26-1

Features

- Compact design
- Simple robust design
- Electrical insulation
- No stick-slip effect
- Large radial shaft misalignment permissible
- Torsionally rigid
- Minimal restoring forces to adjacent machine parts
- Typical applications: Printing machines, machine tools

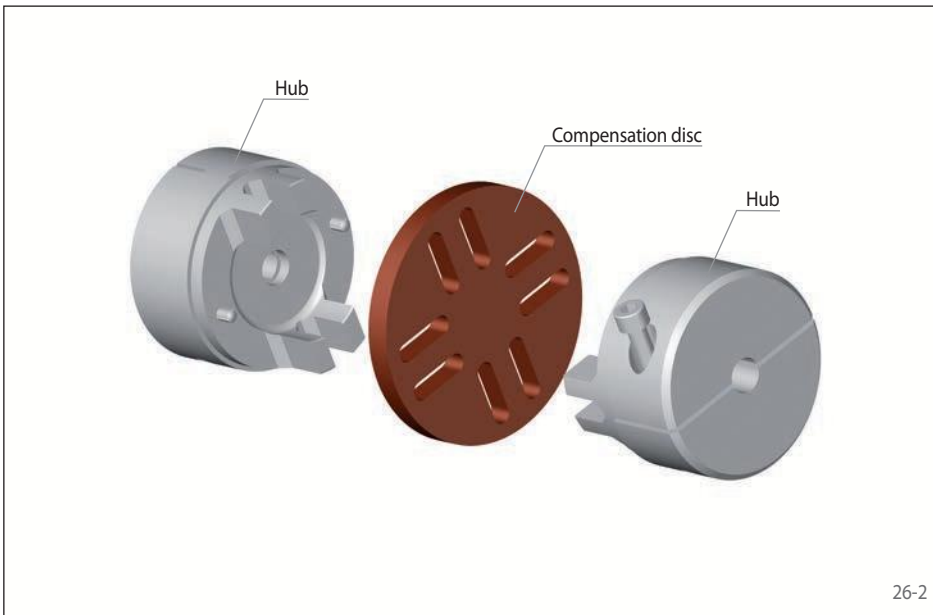

26-2

Order example

Order example	Code
Coupling design	RDA
Coupling size	0010
Type	ESO
Material of the hub: • Steel	STA
Hub A, type: • I, clamping hub	1
Hub A, design: • Clamping hub, single slotted, metric bore, H7, without keyway	KA
Bore diameter hub A	005
Hub B, type: • I, clamping hub	1
Hub B, design: • Clamping hub, single slotted, metric bore, H7, without keyway	KA
Bore diameter hub B	010
Material of the compensation disc: • HGW 2082 in accordance with DIN 7735	HG82

RDA 0010 ESO-STA-1KA005-1KA010-HG82

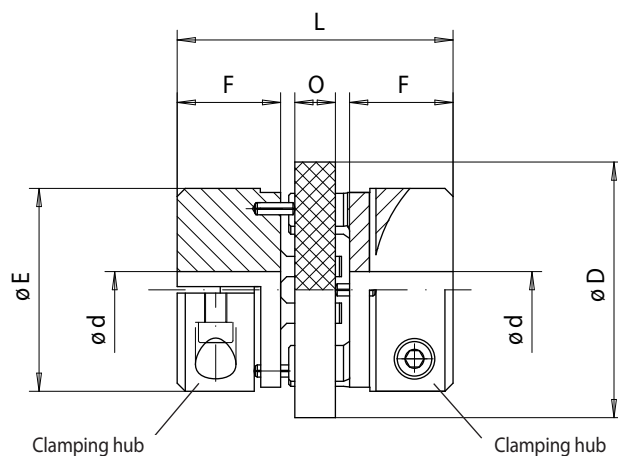

27-1

Coupling size	Max. torque T_{Kmax} Nm	Max. speed n_{max} min ⁻¹	Moment of inertia J_K kgm ²	Max. misalignments*		Finish bore d		D mm	E mm	F mm	L mm	O mm	Weight with rough bore kg
				Axial +/- mm	Radial mm	min. mm	max. mm						
0010	2	13000	0,0001	0,75	0,5	5	10	32	26	13	35	6	0,10
0012	4	10500	0,0002	0,75	0,6	6	14	40	32	16	42	4	0,20
0016	8	8400	0,0003	0,75	0,8	8	20	50	40	18,5	51	6	0,38
0020	16	6800	0,0004	1,00	1,0	10	25	63	50	25	64	6	0,78
0027	32	5350	0,0008	1,25	1,35	12	35	80	65	32	85	8	1,70

For finish bores, please specify bore diameter hub A and hub B. Tolerance of finish bores H7. Keyway tolerance P9.

* max. angular displacement 3°.

Elastomer element	Material	Temperature range °C	Colour
HGW 2082	Cotton fabric-phenolic	up to +100	red

Flexible Couplings RDA ... ESO

Design RDA ... ESO-GJS-2PE ...

Hub with mounting flange with through bores

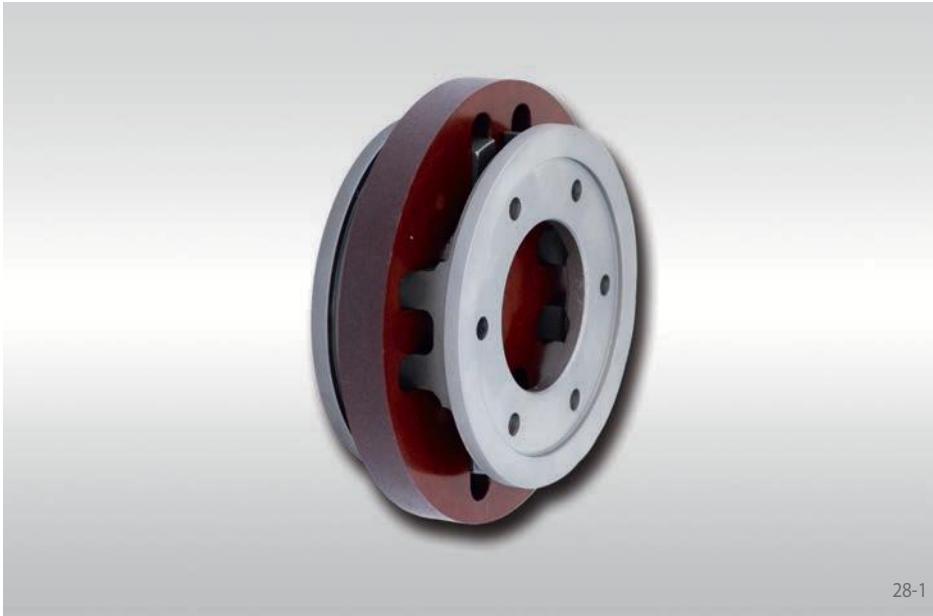

Features

- Compact design
- Simple robust design
- Electrical insulation
- No stick-slip effect
- Large radial shaft misalignment permissible
- Torsionally rigid
- Minimal restoring forces to adjacent machine parts
- Typical application: Printing machines, machine tools

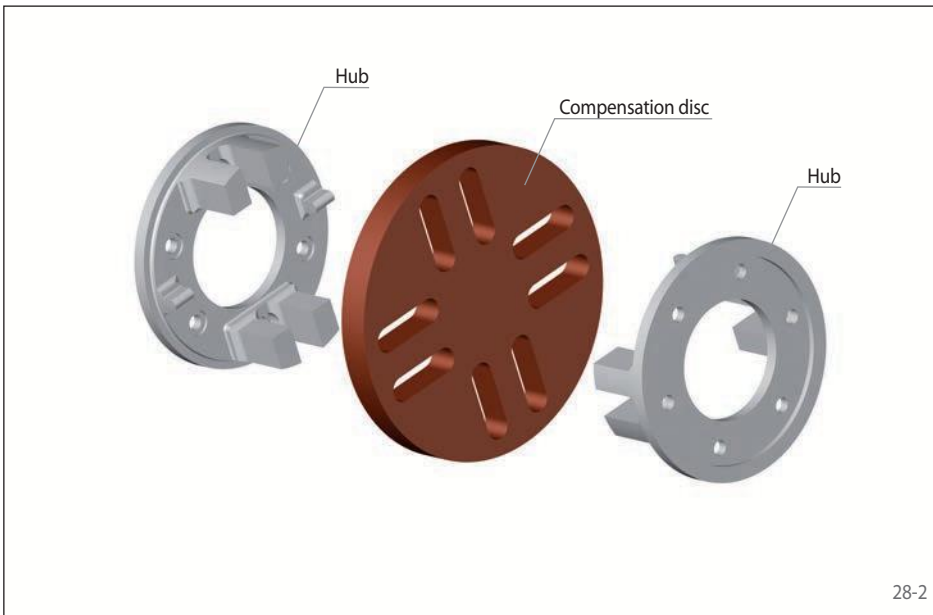

Order example

	Code
Coupling design	RDA
Coupling size	0110
Type	ESO
Material of the hub: • Nodular cast iron	GJS
Hub A, type: • II, flange hub	2
Hub A, design: • Mounting flange with through bore, arrangement of the fastening holes according to hole pattern	PE
Pitch diameter T hub A	180
Hub B, type: • II, flange hub	2
Hub B, design: • Mounting flange with through bore, arrangement of the fastening holes according to hole pattern	PE
Pitch diameter T hub B	180
Material of the compensation disc: • HGW 2082 in accordance with DIN 7735	HG82

RDA 0110 ESO-GJS-2PE180-2PE180-HG82

Design RDA ... ESO-GJS-2PE ...

Hub with mounting flange with through bores

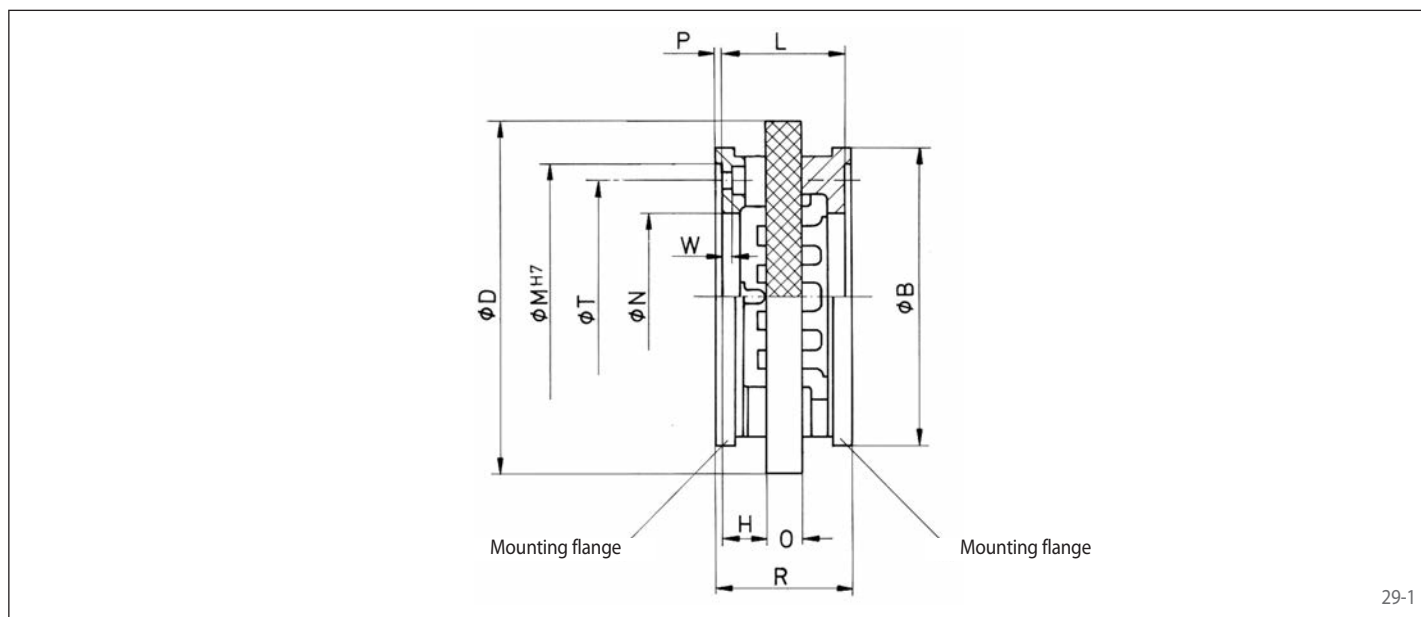

29-1

Coupling size	Max. torque T_{Kmax} Nm	Max. speed n_{max} min^{-1}	Moment of inertia J_k kgm^2	Max. misalignments*		B mm	D mm	H mm	L mm	M ^{H7} mm	N mm	O mm	P mm	R mm	T mm	W mm	Z	Hole pattern**	Weight with rough bore kg
				Axial +/- mm	Radial mm														
0035	85	4100	0,0009	1,50	1,75	90	110	14,5	41	75	45	12	2,5	46	65	3,5	M 6	1	0,7
0042	190	3400	0,0026	1,50	2,1	110	135	15,5	45	90	52	14	2,5	50	75	4,5	M 6	2	1,4
0050	500	2670	0,0053	2,00	2,5	135	160	18,0	52	100	65	16	4,5	61	88	4,5	M 8	2	1,9
0051	500	2670	0,0051	2,00	2,5	135	160	17,5	51	125	76	16	3,0	57	108	5,0	M 8	3	1,7
0070	1000	2140	0,0138	2,00	3,5	163	200	21,0	62	135	90	20	4,0	70	115	5,5	M 10	2	3,2
0090	2000	1700	0,0453	2,50	4,5	202	250	26,5	78	170	104	25	4,5	87	150	7,0	M 10	4	7,0
0110	4000	1350	0,1314	4,00	5,5	254	315	32,0	96	200	146	32	5,0	106	180	5,0	M 12	3	12,3
0140	8000	1050	0,5203	4,50	7,0	330	400	44,0	128	250	157	40	5,0	138	225	8,0	M 16	3	31,2

* max. angular displacement 3°.

** Arrangement of the fastening holes for screws Z (DIN EN ISO 4762) on pitch diameter T. The hole pattern of the respective other coupling half is offset by 90°.

Elastomer element	Material	Temperature range °C	Colour
HGW 2082	Cotton fabric-phenolic	up to +100	red

Arrangement of the fastening holes

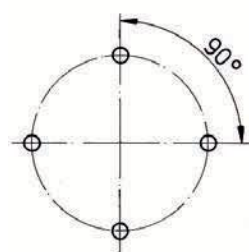

Hole pattern 1

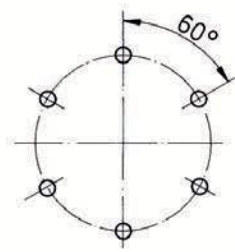

Hole pattern 2

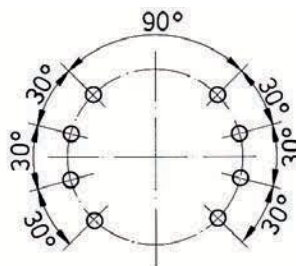

Hole pattern 3

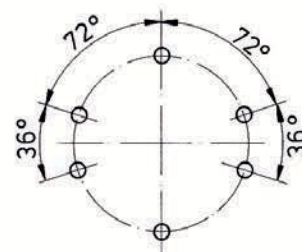





Hole pattern 4

Combination of hub designs

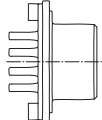

30-1

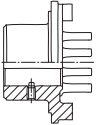
The design of the flexible coupling RDA ... ESO allows for the combination of various hub forms to suit available space.

	 Type 0	 Type I	 Type II
 Type 0	●	●	●
 Type I	●	●	
 Type II	●		●

Order example

	Code
Coupling design	RDA
Coupling size	0035
Type	ESO
Material of the hub: • Nodular cast iron	GJS
Hub A, type: • 0, standard	0
Hub A, design: • finish bored with keyway • roughbored	FB VA
Bore diameter hub A	028
Hub B, type: • II, flange hub	2
Hub B, design: • Mounting flange with through bore, arrangement of the fastening holes according to hole pattern	PE
Pitch diameter T hub B	065
Material of the compensation disc: • HGW 2082 in accordance with DIN 7735	HG82

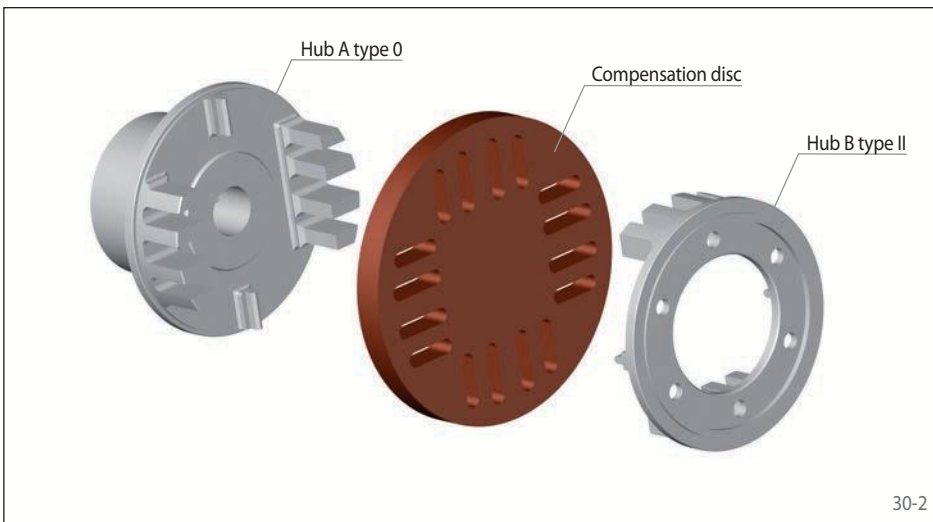

30-2

RDA 0035 ESO-GJS-0FB028-2PE065-HG82

Example hub combination

Hub with mounting flange – hub with keyway

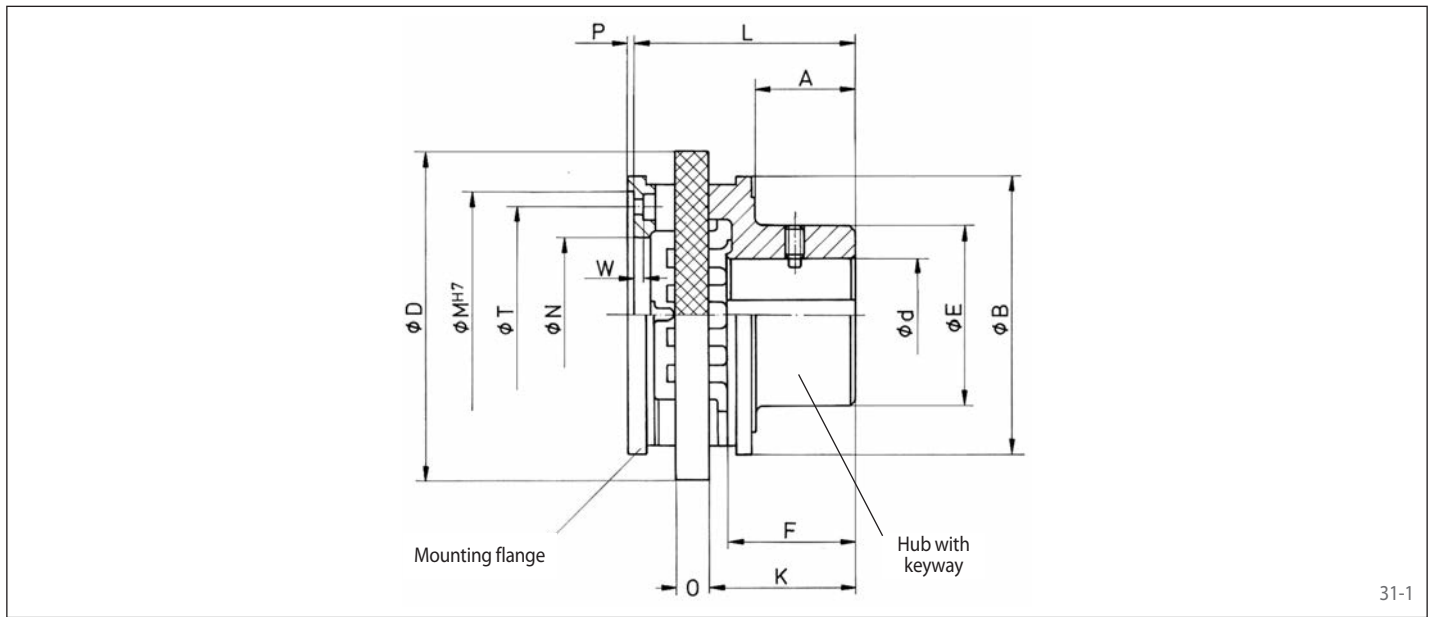

31-1

Coupling size	Max. torque T_{Kmax} Nm	Max. speed n_{max} min ⁻¹	Moment of inertia J_K kgm ²	Max. misalignments*		Pilot bore d mm	Finish bore d		A mm	B mm	D mm	E mm	F** mm	K mm	L mm	M ^{H7} mm	N mm	O mm	P mm	T mm	W mm	Z	Hole pattern***	Weight with rough bore kg
				Axial +/- mm	Radial mm		min. mm	max. mm																
0035	85	4100	0,0011	1,50	1,75	15	16	35	33	90	110	53	42	50,0	76,5	75	45	12	2,5	65	3,5	M 6	1	1,3
0042	190	3400	0,0032	1,50	2,1	19	20	42	41	110	135	66	53	61,0	90,5	90	52	14	2,5	75	4,5	M 6	2	2,6
0050	500	2670	0,0075	2,00	2,5	29	30	50	51	135	160	85	62	71,5	105,5	100	65	16	4,5	88	4,5	M 8	2	4,1
0051	500	2670	0,0074	2,00	2,5	29	30	50	51	135	160	85	62	71,5	105,0	125	76	16	3,0	108	5,0	M 8	3	4,0
0070	1000	2140	0,0203	2,00	3,5	33	34	70	65	163	200	104	79	90,0	131,0	135	90	20	4,0	115	5,5	M 10	2	7,7
0090	2000	1700	0,0782	2,50	4,5	48	50	90	81	202	250	150	100	111	162,5	170	104	25	4,5	150	7,0	M 10	4	18,0
0110	4000	1350	0,2113	4,00	5,5	58	60	110	101	254	315	175	124	140	204,0	200	146	32	5,0	180	5,0	M 12	3	31,6
0140	8000	1050	0,7485	4,50	7,0	72	75	140	130	330	400	216	160	181	265,0	250	157	40	5,0	225	8,0	M 16	3	67,6

Tolerance of finish bores H7. Keyways in accordance with DIN 6885, sheet 1. Keyway tolerance P9.

* max. angular displacement 3°.

** The hub length F can be shortened, which would change the dimensions A, C, K and L accordingly.

*** Arrangement of the fastening holes for screws (DIN EN ISO 4762) on pitch diameter T for coupling half with flange mounting.

Arrangement of the fastening holes

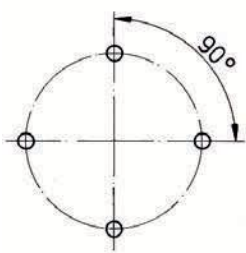

Hole pattern 1

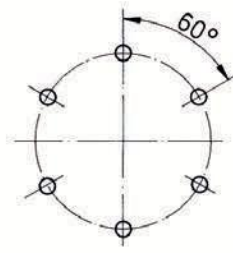

Hole pattern 2

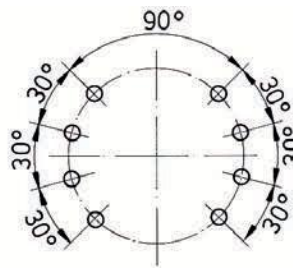

Hole pattern 3

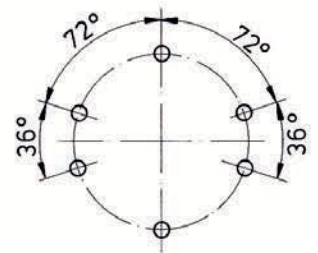

Hole pattern 4

elastic
horizontally split cover



32-1

Features

- High nominal torques up to 335 500 Nm
- Compensation of axial, radial and angular misalignments
- Gradual increase in torsional rigidity as torques increase
- Horizontally split cover
- Easy replacement of the grid
- Typical application: Crushers, reels, mills, calenders, mixers, belt drives

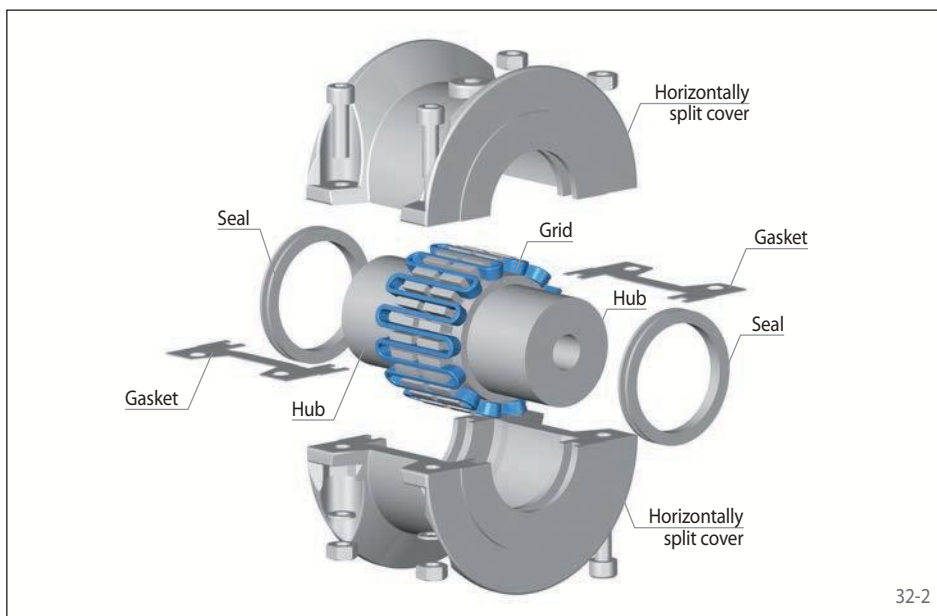

32-2

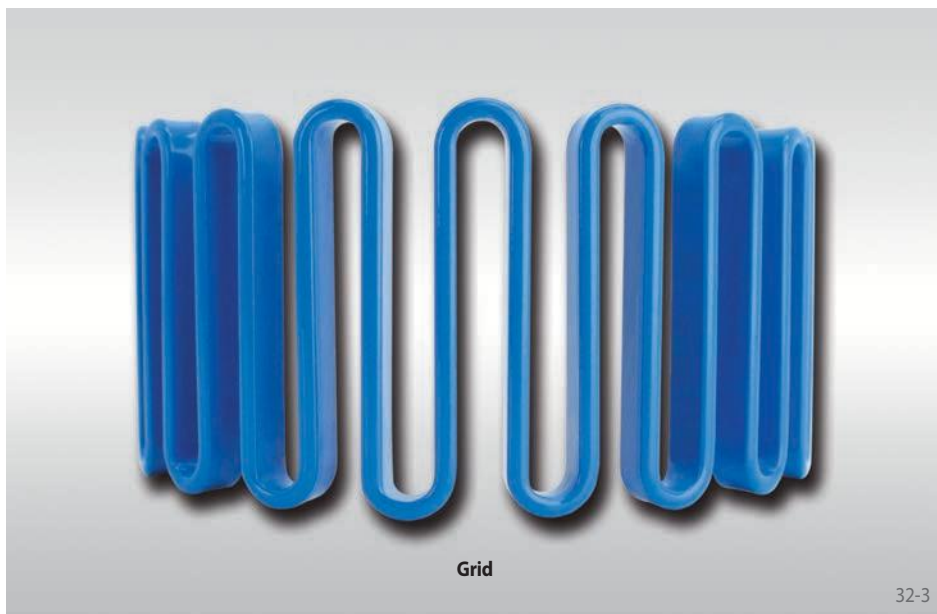

Grid

32-3

Order example

Order example	Code
Coupling design	RES
Coupling size	1030
Type	EYO
Material of the hub: • Steel	STA
Hub A, type: • 0, standard	0
Hub A, design: • finish bored with keyway • roughbored	FB VA
Bore diameter hub A	025
Hub B, type: • 0, standard	0
Hub B, design: • finish bored with keyway • roughbored	FB VA
Bore diameter hub B	032
Grid	ST00

RES 1030 EYO-STA-0FB025-0FB032-ST00

elastic
horizontally split cover

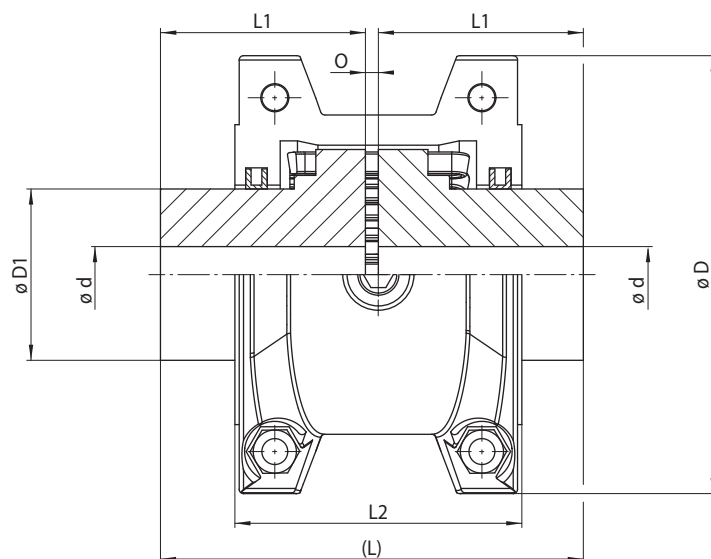

33-1

Coupling size	Nominal torque T_{KN} Nm	Nominal power at 100 min^{-1} P_{K100} kW	Max. speed n_{max} min^{-1}	Pilot bore d^* mm	Bore d^*		D mm	D1 mm	L mm	L1 mm	L2 mm	O mm	Permissible misalignments			Weight grease filling kg	Weight with max. bore kg
					min. mm	max. mm							Axial mm	Radial mm	Angular °		
1020	48	0,50	4500	16	18	30	101,5	39,7	98,0	47,5	66,5	3,0	±0,3	0,3	0,25	0,03	1,9
1030	136	1,42	4500	16	18	36	110,0	49,2	98,0	47,5	68,0	3,0	±0,3	0,3		0,03	2,6
1040	226	2,36	4500	16	18	44	117,5	57,1	104,5	51,0	70,0	3,0	±0,3	0,3		0,05	3,4
1050	395	4,14	4500	16	18	51	138,0	66,7	123,5	60,0	79,5	3,0	±0,3	0,4		0,05	5,4
1060	620	6,50	4350	18	20	56	150,5	76,2	130,0	63,5	92,0	3,0	±0,3	0,4		0,09	7,3
1070	900	9,46	4125	18	20	67	162,0	87,3	155,5	76,0	95,0	3,0	±0,3	0,4		0,11	10,0
1080	1860	19,51	3600	25	27	80	194,0	104,8	181,0	89,0	116,0	3,0	±0,3	0,4		0,17	18,0
1090	3380	35,47	3600	25	27	95	213,0	123,8	200,0	98,5	122,0	3,0	±0,3	0,4		0,25	25,0
1100	5700	59,71	2400	40	42	110	250,0	142,0	245,5	120,5	155,5	4,5	±0,45	0,4		0,43	42,0
1110	8400	88,67	2250	37	42	120	270,0	160,3	258,5	127,0	161,5	4,5	±0,45	0,5		0,51	54,0
1120	12400	130,05	2025	56	61	140	308,0	179,4	304,5	149,5	191,5	6,0	±0,6	0,5		0,73	81,0
1130	18000	189,17	1800	62	67	170	346,0	217,5	330,0	162,0	195,0	6,0	±0,6	0,56		0,91	121
1140	25900	271,93	1650	62	67	200	384,0	254,0	371,5	183,0	201,0	6,0	±0,6	0,56		1,13	178
1150	36100	378,34	1500	103	108	215	453,0	269,2	372,0	183,0	271,0	6,0	±0,6	0,56		1,95	234
1160	50500	532,04	1350	116	121	240	501,5	304,8	402,0	198,0	279,0	6,0	±0,6	0,6		2,81	317
1170	67500	709,38	1225	129	134	280	566,5	355,6	438,0	216,0	304,0	6,0	±0,6	0,6		3,49	448
1180	93500	983,68	1100	148	153	300	630,0	393,7	483,5	239,0	321,0	6,0	±0,6	0,76		3,76	619
1190	124000	1300,53	1050	148	153	335	675,5	436,9	524,5	259,0	325,0	6,0	±0,6	0,76		4,40	776
1200	169000	1773,46	900	173	178	360	757,0	497,8	565,0	279,5	355,5	6,0	±0,6	0,76		5,62	1058
1210	248500	2605,47	820	173	178	390	844,5	533,4	622,5	305,0	432,0	12,7	±0,6	0,76		10,5	1424
1220	335500	3515,89	730	198	203	420	920,5	571,5	663,0	325,1	490,0	12,7	±0,6	0,76	16,1	1785	

For finish bores, please specify bore diameter hub A and hub B. Tolerance of finish bores H7. Keyways in accordance with DIN 6885, sheet 1. Keyway tolerance JS9.
* Bores also available in inch size, see page 68.

elastic
vertically split cover

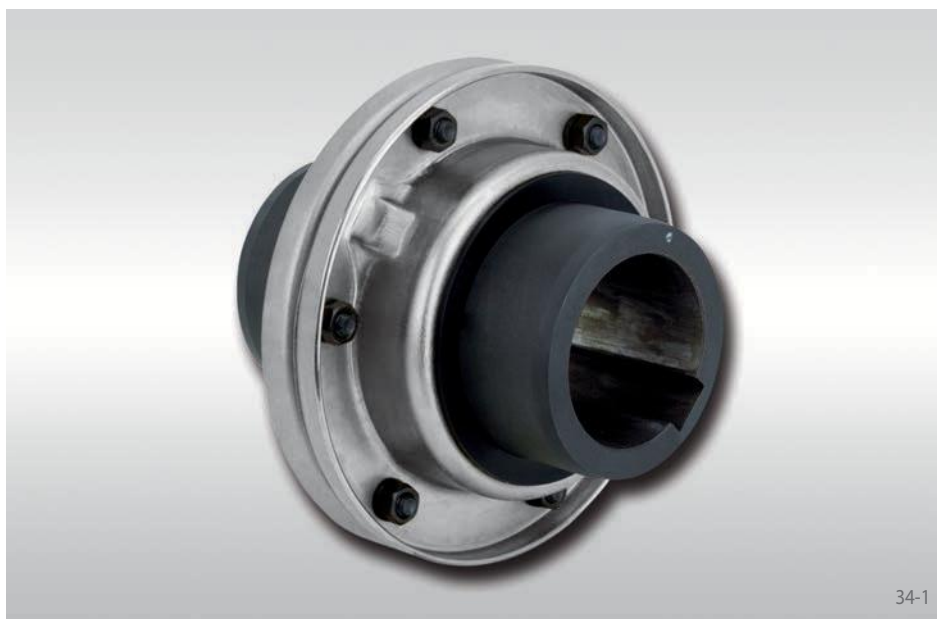

34-1

Features

- Nominal torques up to 169 000 Nm
- Compensation of axial, radial and angular misalignments
- Gradual increase in torsional rigidity as torques increase
- Vertically split cover
- Easy replacement of the grid
- Typical application: Crushers, reels, mills, calenders, mixers, belt drives

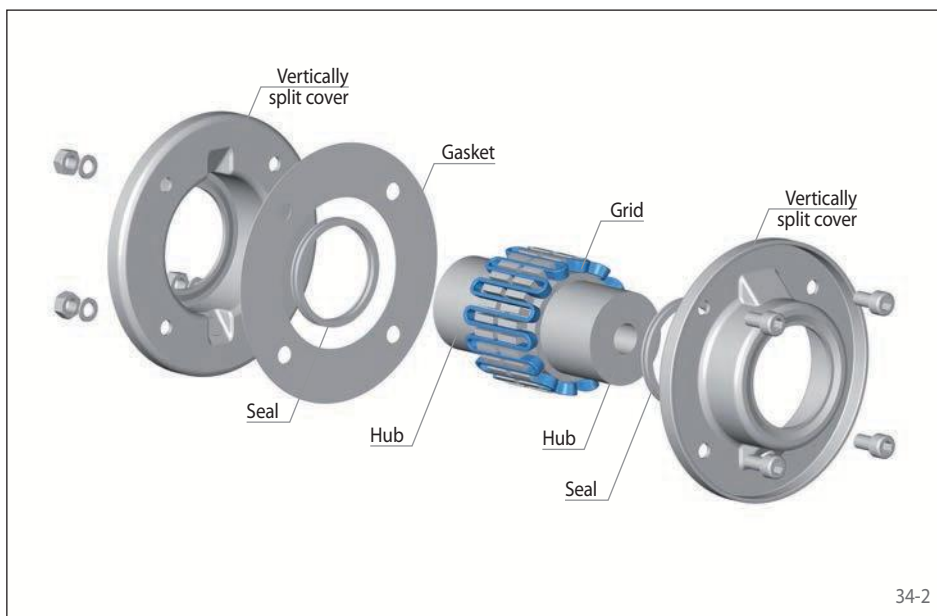

34-2

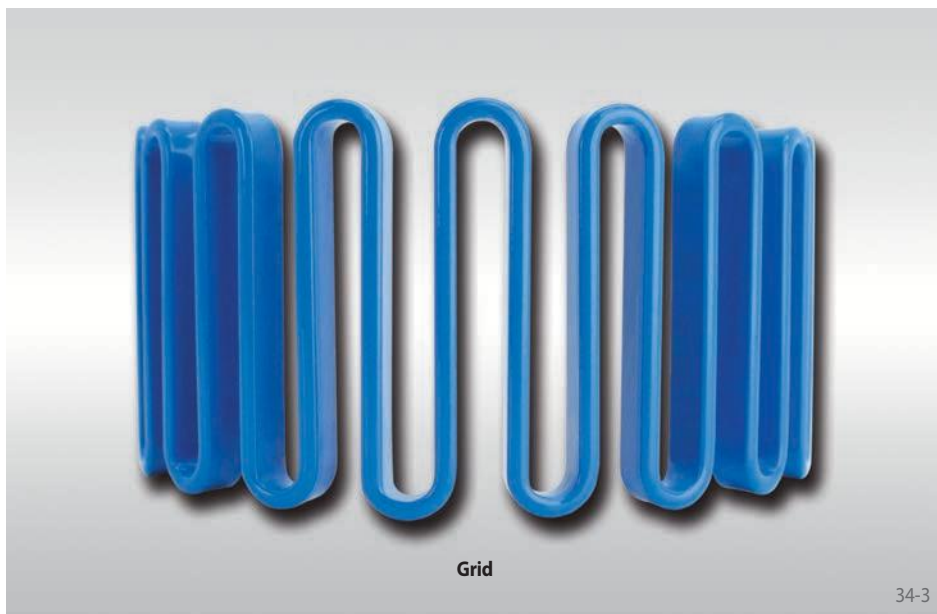

Grid

34-3

Order example

Order example	Code
Coupling design	RES
Coupling size	1030
Type	ETO
Material of the hub: • Steel	STA
Hub A, type: • 0, standard	0
Hub A, design: • finish bored with keyway • roughbored	FB VA
Bore diameter hub A	025
Hub B, type: • 0, standard	0
Hub B, design: • finish bored with keyway • roughbored	FB VA
Bore diameter hub B	032
Grid	ST00

RES 1030 ETO-STA-0FB025-0FB032-ST00

elastic
vertically split cover

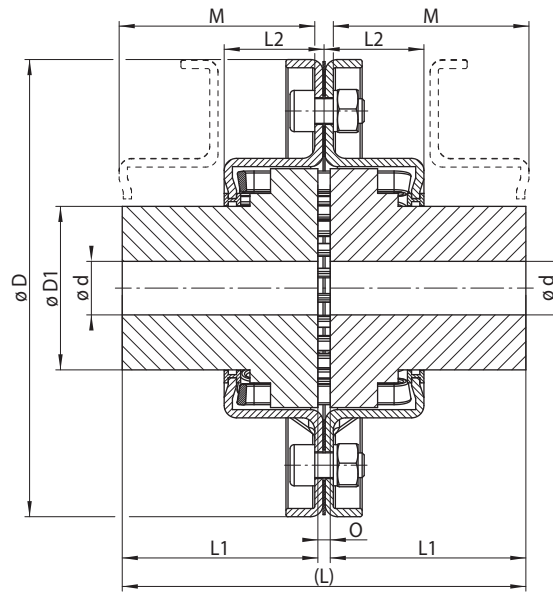

35-1

Coupling size	Nominal torque T_{KN} Nm	Nominal power at 100 min^{-1} P_{K100} kW	Max. speed n_{max} min^{-1}	Pilot bore d^* mm	Bore d^*		D mm	D1 mm	L mm	L1 mm	L2 mm	M** mm	O mm	Permissible misalignments			Weight grease filling kg	Weight with max. bore kg
					min. mm	max. mm								Axial mm	Radial mm	Angular °		
1020	48	0,50	6000	16	18	30	111,0	39,7	98,0	47,5	24,0	47,5	3,0	±0,3	0,3	0,03	2,0	
1030	136	1,40	6000	16	18	36	121,0	49,2	98,0	47,5	25,0	47,5	3,0	±0,3	0,3	0,03	2,6	
1040	226	2,30	6000	16	18	44	128,5	57,1	104,5	51,0	25,5	51,0	3,0	±0,3	0,3	0,05	3,4	
1050	395	4,10	6000	16	18	51	147,5	66,7	123,5	60,5	31,0	60,5	3,0	±0,3	0,4	0,05	5,4	
1060	620	6,49	6000	18	20	56	162,0	76,2	130,0	63,5	32,0	63,5	3,0	±0,3	0,4	0,09	7,3	
1070	900	9,39	5500	18	20	67	173,0	87,3	155,5	76,0	33,5	76,0	3,0	±0,3	0,4	0,11	10,4	
1080	1860	19,48	4750	25	27	80	200,0	104,8	181,0	89,0	44,0	89,0	3,0	±0,3	0,4	0,17	17,7	
1090	3380	34,96	4000	25	27	95	232,0	123,8	200,0	98,5	47,5	98,5	3,0	±0,3	0,4	0,25	25,4	
1100	5700	59,44	3250	40	42	110	267,0	142,0	245,5	120,5	60,0	120,5	4,5	±0,45	0,4	0,43	42,2	
1110	8400	87,90	3000	37	42	120	286,0	160,3	258,5	127,0	64,0	127,0	4,5	±0,45	0,5	0,51	54,4	
1120	12400	129,86	2700	56	61	140	319,0	179,4	304,5	149,0	73,5	149,0	6,0	±0,6	0,5	0,73	81,6	
1130	18000	188,79	2400	62	67	170	378,0	217,5	330,0	162,0	75,0	162,0	6,0	±0,6	0,56	0,91	122,5	
1140	25900	271,70	2200	62	67	200	416,0	254,0	371,5	183,0	78,0	183,0	6,0	±0,6	0,56	1,13	180,1	
1150	36100	378,59	2000	103	108	215	476,5	269,2	372,0	183,0	107,0	183,0	6,0	±0,6	0,56	1,95	230,0	
1160	50500	532,40	1750	116	121	240	533,5	304,8	402,0	198,0	114,5	198,0	6,0	±0,6	0,6	2,81	321,1	
1170	67500	709,38	1600	129	134	280	584,0	355,6	438,0	216,0	120,0	216,0	6,0	±0,6	0,6	3,49	448,2	
1180	93500	983,68	1400	148	153	300	630,0	393,7	483,5	239,0	130,0	239,0	6,0	±0,6	0,76	3,76	591,0	
1190	124000	1300,53	1300	148	153	335	685,0	436,9	524,0	260,0	135,0	259,0	6,0	±0,6	0,76	4,4	761,0	
1200	169000	1773,46	1100	173	178	360	737,0	497,8	565,0	279,5	145,0	279,5	6,0	±0,6	0,76	5,62	1021,0	

For finish bores, please specify bore diameter hub A and hub B. Tolerance of finish bores H7. Keyways in accordance with DIN 6885, sheet 1. Keyway tolerance JS9.

* Bores also available in inch size, see page 68.

** Minimum necessary space to align the shafts.

elastic
lubrication-free



Features

- Vertical/horizontal mounting
- Adsorbs vibrations
- Progressive torsion spring properties due to primarily pressurised bushings
- Fail-safe in the event of the failure of the bushings
- Easy replacement of bushings without disassembly of the coupling halves
- Maintenance free, no lubrication necessary
- Declaration of conformity in accordance with ATEX 2014/34/EU possible
- Typical applications: Pump drives, belt drives, ventilators, general mechanical engineering

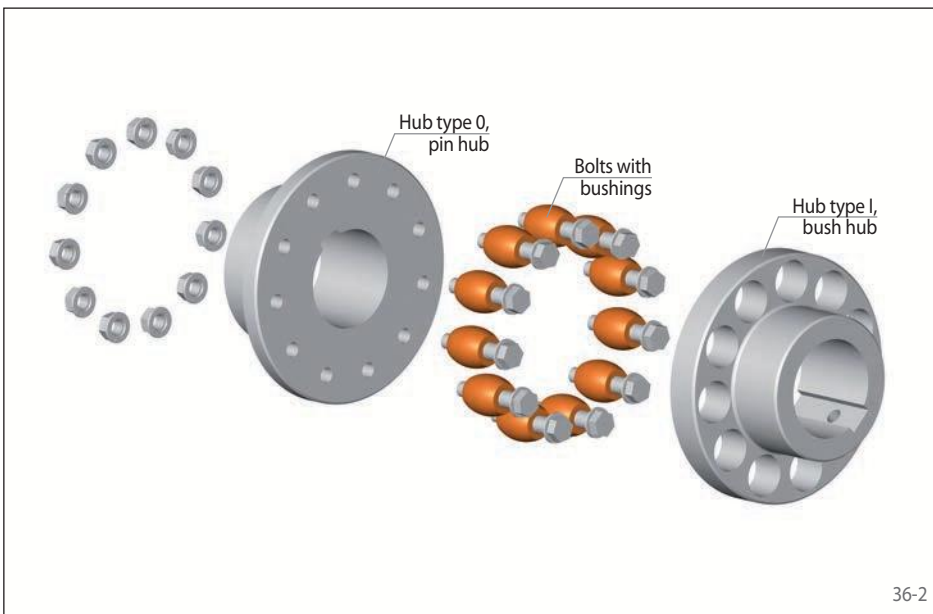

Order example

Order example	Code
Coupling design	REB
Coupling size	0105
Type	DCO
Material of the hub:	GJL
• Cast iron	
Hub A, type:	
• 0, standard, pin hub (up to size 0360)	0
• II, standard, pin and bush hub (from size 0410)	2
Hub A, design:	
• finish bored with keyway	FB
• roughbored	VA
Bore diameter hub A	030
Hub B, type:	
• I, standard, bush hub (up to size 0360)	1
• II, standard, pin and bush hub (from size 0410)	2
Hub B, design:	
• finish bored with keyway	FB
• roughbored	VA
Bore diameter hub B	028
Material of bushings:	
• NR 80 Shore-A	NR80
• PU 92 Shore-A	PU92
• HTrans	HT00



REB 0105 DCO-GJL-0FB030-1FB028-NR80

elastic
lubrication-free

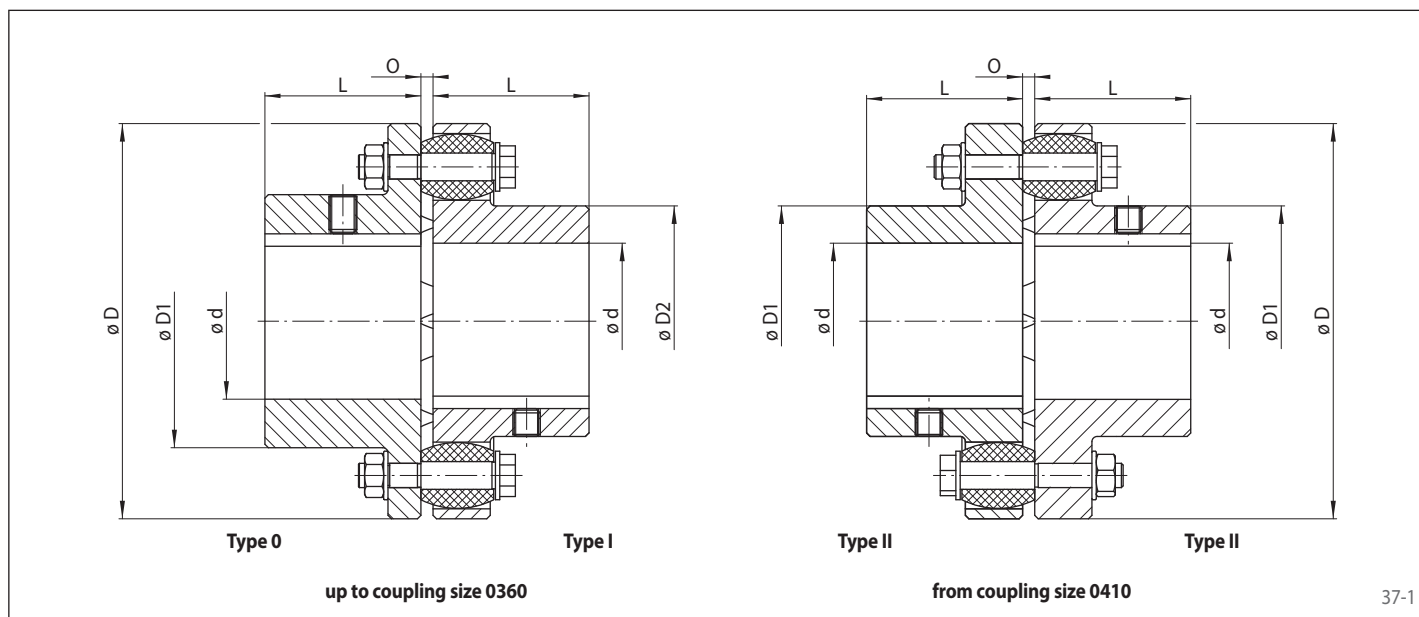

Coupling size	Max. speed n_{max} min ⁻¹	Moment of inertia with max. bore J_k kgm ²	Pilot bore d^* mm	Min. bore d^*			Max. bore d^*			D mm	D1 mm	D2 mm	L mm	O mm	Permissible misalignments			Weight with max. bore kg
				Hub type 0 mm	Hub type I mm	Hub type II mm	Hub type 0 mm	Hub type I mm	Hub type II mm						Axial mm	Radial mm	Angular °	
0105	7200	0,003	13	15	15	-	32	30	-	105	50	48	45	2-6	2	0,3	1	2
0116	6100	0,005	13	15	15	-	42	39	-	116	68	60	45	2-6	2	0,3	1	2,6
0125	5500	0,007	13	15	15	-	50	45	-	125	78	68	50	2-6	2	0,4	1	3,1
0144	4900	0,012	16	18	18	-	60	50	-	144	91	82	55	2-6	2	0,4	1	4,3
0162	4500	0,030	20	22	22	-	65	60	-	162	100	89	60	2-6	2	0,4	1	7,5
0178	3800	0,040	22	24	24	-	75	70	-	178	115	105	70	2-6	2	0,5	1	10
0198	3400	0,062	26	28	28	-	90	80	-	198	135	124	80	2-6	2	0,5	1	13
0228	3000	0,10	26	28	28	-	100	90	-	228	146	133	90	4-10	3	0,6	1	18
0252	2700	0,17	36	38	38	-	115	105	-	252	167	156	100	4-10	3	0,6	1	24
0285	2400	0,31	46	48	48	-	125	115	-	285	186	170	110	4-10	3	0,7	1	35
0320	2100	0,53	53	55	55	-	135	125	-	320	212	196	125	4-10	3	0,7	1	51
0360	1900	1,02	63	65	65	-	150	135	-	360	232	212	140	4-12	4	0,9	1	73
0410	1700	1,70	73	-	-	75	-	-	160	410	230	-	160	4-12	4	1,1	1	101
0450	1500	2,90	83	-	-	85	-	-	180	450	260	-	180	4-12	4	1,1	0,5	137
0500	1350	4,70	93	-	-	95	-	-	200	500	290	-	200	4-12	4	1,1	0,4	180
0560	1200	10,7	93	-	-	95	-	-	225	560	320	-	220	4-8	2	1,5	0,3	278
0630	1050	17,4	98	-	-	100	-	-	250	630	355	-	240	4-8	2	1,5	0,3	365
0710	950	33,0	98	-	-	100	-	-	260	710	385	-	260	5-9	2	1,8	0,3	516
0800	850	53,0	98	-	-	100	-	-	280	800	420	-	290	5-9	2	1,8	0,3	691
0900	750	86,0	98	-	-	100	-	-	305	900	465	-	320	5-9	2	1,8	0,3	927
1000	680	142,8	115	-	-	125	-	-	320	1000	515	-	350	5-10	2	2,0	0,1	1224
1120	600	231,0	125	-	-	135	-	-	350	1120	560	-	380	6-11	2	2,2	0,1	1584
1250	550	367,5	140	-	-	150	-	-	380	1250	610	-	420	6-11	2	2,4	0,1	2070
1400	490	693,0	165	-	-	175	-	-	440	1400	700	-	480	6-12	2	2,7	0,1	3060
1600	430	1155	190	-	-	200	-	-	480	1600	770	-	540	6-12	2	3,0	0,1	3960
1800	380	2205	215	-	-	225	-	-	540	1800	870	-	600	8-16	2	3,4	0,1	5760
2000	340	3255	240	-	-	250	-	-	600	2000	960	-	660	8-16	2	3,8	0,1	7020

For finish bores, please specify bore diameter hub A and hub B. Tolerance of finish bores H7. Keyways in accordance with DIN 6885, sheet 1. Keyway tolerance JS9.
The couplings can be momentarily overloaded at start-up by up to three times the nominal torque.
For vertical installation, please contact RINGSPANN.
See following pages for performance data.
* Bores also available in inch size, see page 68.

Bushings



Bushing NR 80 Shore-A

Material: Natural rubber
 Hardness: 80 ±5 Shore -A
 Temperature range: -45 °C to +70 °C
 Colour: black



Bushing PU 92 Shore-A

Material: Polyurethane
 Hardness: 92 ±5 Shore-A
 Temperature range: -30 °C to +80 °C
 Colour: orange

Coupling size	Nominal torque T_{KN} Nm	Nominal power at 100 min^{-1} P_{K100} kW	Max. torque $T_{K \max}$ Nm	Alternating torque T_{KW} Nm	Torsional stiffness $C_{T \text{ dyn}}$ Nm/rad x 10^3			Relative damping ψ at 0,5 T_{KN}
					1,0	0,5	0,25	
					T_{KN}	T_{KN}	T_{KN}	
0105	95	1,0	285	19	12	6	5	1,4
0116	146	1,5	438	29	21	11	8	
0125	166	1,7	498	33	27	14	10	
0144	318	3,3	954	64	59	32	22	
0162	520	5,5	1570	105	88	47	33	
0178	640	6,7	1920	129	126	70	37	
0198	1240	13	3740	250	279	155	82	
0228	2050	21	6100	410	406	225	119	
0252	3060	32	9200	614	689	382	202	
0285	4550	48	13600	910	1052	547	272	
0320	6000	64	18200	1220	5045	1894	814	
0360	8900	93	26700	1780	6653	2498	1073	
0410	12000	126	36100	2410	8066	3029	1301	
0450	18600	195	55500	3720	13973	5247	2254	
0500	25800	270	77000	5160	21481	8066	3465	
0560	31000	325	93000	6201	19199	7209	3097	
0630	41900	440	125500	8400	29671	11141	4786	
0710	75000	785	225000	15000	45968	17260	7415	
0800	100000	1047	300000	20000	69131	25957	11151	
0900	154500	1623	464500	31000	119868	45008	19335	
1000	194500	2042	584500	38999	172799	64883	27873	
1120	269500	2827	809500	53999	224141	84161	36155	
1250	344500	3613	1034500	68999	317491	119212	51213	
1400	529500	5550	1589500	106000	488695	183496	78829	
1600	749500	7854	2249500	149999	776595	291597	125269	
1800	974500	10210	2924500	194999	1020539	383193	164618	
2000	1299500	13614	3899500	259999	1511459	567524	243806	

Coupling size	Nominal torque T_{KN} Nm	Nominal power at 100 min^{-1} P_{K100} kW	Max. torque $T_{K \max}$ Nm	Alternating torque T_{KW} Nm	Torsional stiffness $C_{T \text{ dyn}}$ Nm/rad x 10^3			Relative damping ψ at 0,5 T_{KN}
					1,0	0,5	0,25	
					T_{KN}	T_{KN}	T_{KN}	
0105	143	1,5	429	29	11	9	6	0,5
0116	220	2,3	660	44	20	16	10	
0125	248	2,6	740	50	25	20	13	
0144	478	5,0	1430	96	55	44	30	
0162	790	8,3	2370	159	82	65	45	
0178	960	10,1	2890	193	105	85	62	
0198	1860	19,5	5500	372	230	186	136	
0228	3000	31,5	9000	602	326	264	193	
0252	4580	48,0	13700	917	562	455	333	
0285	6800	72,0	20600	1375	893	721	559	
0320	9100	96,0	27500	1834	2035	1093	686	
0360	13300	139,5	39900	2664	2660	1429	897	
0410	18000	189,0	54000	3610	3225	1732	1088	
0450	27900	292,5	83500	5587	5651	3034	1906	
0500	38600	405,0	116000	7736	8687	4665	2930	
0560	46500	487,5	139500	9311	7764	4169	2619	
0630	63000	660,0	189000	12606	11999	6443	4048	
0710	112000	1177,5	337000	22490	18590	9982	6271	
0800	149500	1570,5	449500	29997	27957	15012	9431	
0900	232000	2434,5	697000	46499	48475	26030	16353	
1000	292500	3063,0	877500	58503	69881	37524	23574	

Bushings



39-1

Bushing HTrans

Material: Polyurethane
 Hardness: 55 ±2 Shore-D
 Temperature range: -30 °C to +120 °C
 Colour: white

Coupling size	Nominal torque T_{KN} Nm	Nominal power at 100 min^{-1} P_{K100} kW	Max. torque T_{Kmax} Nm	Alter-nating torque T_{KW} Nm	Torsional stiffness $C_{T \text{ dyn}}$ Nm/rad x 10^3			Relative damping ψ at 0,5 T_{KN}
					1,0 T_{KN}	0,5 T_{KN}	0,25 T_{KN}	
0105	287	3	860	57	28	25	20	0,43
0116	382	4	1140	76	43	38	31	
0125	382	4	1140	76	48	42	34	
0144	760	8	2290	153	110	96	79	
0162	1330	14	4010	267	172	150	123	
0178	1620	17	4870	325	213	186	151	
0198	3150	33	9400	630	471	411	335	
0228	5000	53	15100	1012	668	583	475	
0252	7600	80	22900	1528	1143	997	813	
0285	11400	120	34300	2292	1444	1197	952	
0320	15200	160	45800	3056	2159	1790	1424	
0360	22200	233	66500	4450	2836	2351	1871	

Jaw Couplings REK ... DQO

elastic for dynamic applications
with radially mountable elastomer cushions

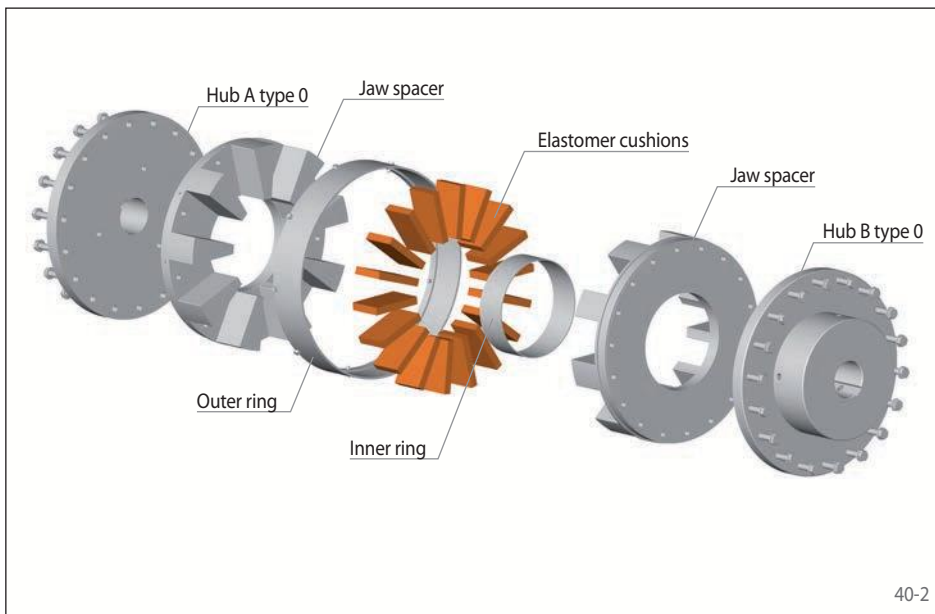

Features

- Nominal torques up to 169 000 Nm
- Compensation of axial, radial and angular misalignments
- Adsorbs vibrations
- Progressive torsion spring properties due to primarily pressurised elastomer cushions
- Fail-safe in the event of the failure of the elastomer cushions
- Maintenance free, no lubrication necessary
- Elastomer cushions radially replaceable without moving the drive
- Declaration of conformity in accordance with ATEX 2014/34/EU possible
- Typical application: Piston pumps and piston compressors, diesel motors, gas motors, heavy duty applications

Order example

	Code
Coupling design	REK
Coupling size	0075
Type	DQO
Material of the hub*:	
• Cast iron	GJL
• Nodular cast iron	GJS
Hub A, type:	
• 0, standard	0
• I, extended, increased max. bore	1
Hub A, design:	
• finish bored with keyway	FB
• roughbored	VA
Bore diameter hub A	050
Hub B, type:	
• 0, standard	0
• I, extended, increased max. bore	1
Hub B, design:	
• finish bored with keyway	FB
• roughbored	VA
Bore diameter hub B	080
Elastomer cushions:	
• NBR 92 Shore-A	NB92
• PU 92 Shore-A	PU92
• HTrans	HT00

REK 0075 DQO-GJL-0FB050-0FB080-NB92

* See opposite table for availability

Jaw Couplings REK ... DQO

elastic for dynamic applications
with radially mountable elastomer cushions

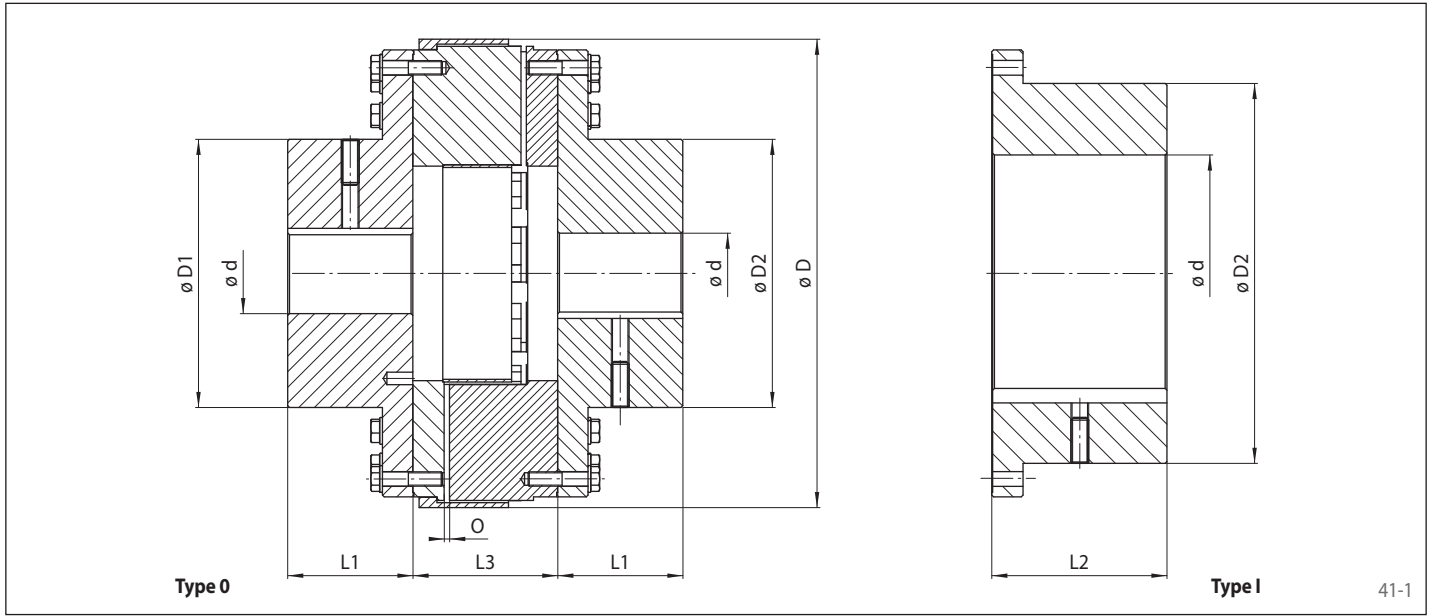

Coupling size	Material of hub		Max. speed n_{max}		Permissible misalignments		
	Cast iron	Nodular cast iron	Cast iron min^{-1}	Nodular cast iron min^{-1}	Axial mm	Radial mm	Angular °
0075	x	x	2257	3385	$\pm 0,375$	0,1	0,25
0090	x	x	2047	3071	$\pm 0,375$		
0100	x	x	1880	2819	$\pm 0,375$		
0125	-	x	-	2544	$\pm 0,375$		
0140	-	x	-	2205	$\pm 0,375$		
0160	-	x	-	2150	$\pm 0,75$		
0180	-	x	-	1932	$\pm 0,75$		
0190	-	x	-	1693	$\pm 0,75$		
0215	-	x	-	1495	$\pm 0,75$		
0260	-	x	-	1354	$\pm 0,75$		

Coupling size	Pilot bore d^*		Min. bore d^*		Max. bore d^*		D	D1	D2	L1	L2	L3	O	Weight with max. bore kg
	Hub type 0	Hub type I	Hub type 0	Hub type I	Hub type 0	Hub type I								
	mm	mm	mm	mm	mm	mm								
0075	28	58	30	60	80	105	266	131	170	68	85	100	3	53,3
0090	33	58	35	60	85	115	292	138	180	76	95	110	3	68,3
0100	38	68	40	70	100	130	317	162	210	84	105	117	3	97,9
0125	48	83	50	85	120	155	349	195	248	95	120	126	3	102,2
0140	58	83	60	85	140	185	400	220	294	100	130	134	3	145,1
0160	68	88	70	90	145	190	412	230	305	110	140	133	6	152,8
0180	83	98	85	100	170	225	461	275	360	130	170	142	6	197,0
0190	88	98	90	100	190	265	524	300	425	140	195	162	6	287,7
0215	98	118	100	120	215	295	600	345	470	155	210	196	6	456,0
0260	108	168	110	170	265	340	667	420	545	190	240	216	6	667,6

For finish bores, please specify bore diameter hub A and hub B. Tolerance of finish bores H7. Keyways in accordance with DIN 6885, sheet 1. Keyway tolerance JS9, different bore and keyway tolerances on request.

The weight refers to a combination of hub type 0 and hub type I with max. possible bore diameter respectively.

Upon request: Varying DBSEs L3

For vertical installation, please contact RINGSPANN.

See following pages for performance data.

* Bores also available in inch size, see page 68.

Elastomer cushions



Elastomer cushion NBR 92 Shore-A

Material: Nitrile rubber
 Hardness: 92 ±5 Shore-A
 Temperature range: -40 °C to +100 °C
 Colour: black

Elastomer cushion PU 92 Shore-A

Material: Polyurethane
 Hardness: 92 ±5 Shore-A
 Temperature range: -30 °C to +80 °C
 Colour: orange

Coupling size	Nominal torque T_{KN}	Nominal power at 100 min^{-1} P_{K100}	Max. torque T_{Kmax}	Alternating torque T_{kW}
	Nm	kW	Nm	Nm
0075	5300	56	10600	1060
0090	7100	75	14200	1420
0100	9900	104	19800	1980
0125	-	-	-	-
0140	-	-	-	-
0160	-	-	-	-
0180	-	-	-	-
0190	-	-	-	-
0215	-	-	-	-
0260	-	-	-	-

Coupling size	Nominal torque T_{KN}	Nominal power at 100 min^{-1} P_{K100}	Max. torque T_{Kmax}	Alternating torque T_{kW}
	Nm	kW	Nm	Nm
0075	8000	84	16000	1600
0090	10600	112	21200	2120
0100	14800	156	29600	2960
0125	21200	223	42400	4240
0140	28800	302	57600	5760
0160	34100	358	68200	6820
0180	50000	527	100000	10000
0190	70000	738	140000	14000
0215	-	-	-	-
0260	-	-	-	-

Elastomer cushions



Elastomer cushion HTrans

Material: Polyurethane
 Hardness: 55 ±2 Shore-D
 Temperature range: -30 °C to +120 °C
 Colour: white

Coupling size	Nominal torque T_{KN}	Nominal power at 100 min^{-1} P_{K100}	Max. torque T_{Kmax}	Alternating torque T_{KW}
	Nm	kW	Nm	Nm
0075	13 300	140	26 600	2 660
0090	17 800	187	35 600	3 560
0100	24 800	260	49 600	4 960
0125	35 500	372	71 000	7 100
0140	47 900	502	95 800	9 580
0160	57 000	597	114 000	11 400
0180	83 500	877	167 000	16 700
0190	117 000	1 230	234 000	23 400
0215	146 000	1 530	292 000	29 200
0260	169 000	1 770	338 000	33 800

Jaw Couplings REK ... DGO

elastic for dynamic applications
with enclosed elastic elements



44-1

Features

- Compensation of axial, radial and angular misalignments
- Adsorbs vibrations
- Progressive torsion spring properties due to primarily pressurised elastic elements
- Fail-safe in the event of the failure of the elastic elements
- Maintenance free, no lubrication necessary
- Declaration of conformity in accordance with ATEX 2014/34/EU possible
- Typical application: Pump drives, ventilator drives, crane trolleys

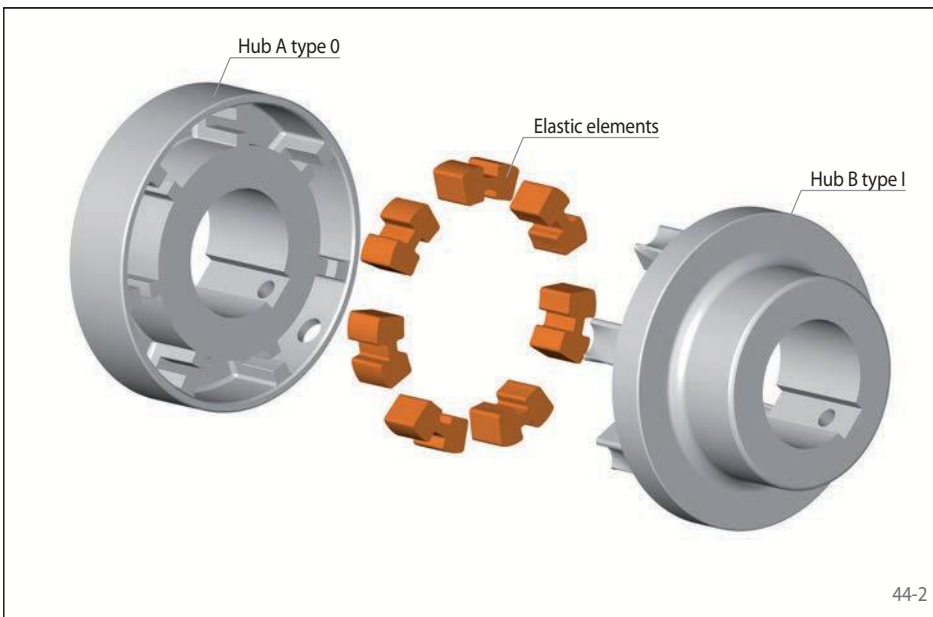

44-2

Order example

Order example	Code
Coupling design	REK
Coupling size	0024
Type	DGO
Material of the hub: • Cast iron	GJL
Hub A, type: • 0, elastomer part	0
Hub A, design: • finish bored with keyway • roughbored	FB VA
Bore diameter hub A	020
Hub B, type: • I, jaws	1
Hub B, design: • finish bored with keyway • roughbored	FB VA
Bore diameter hub B	024
Elastic elements: • NBR 75 Shore-A • PU 92 Shore-A • HTrans	NB75 PU92 HT00

REK 0024 DGO-GJL-0FB020-1FB024-NB75



44-3

elastic for dynamic applications
with enclosed elastic elements

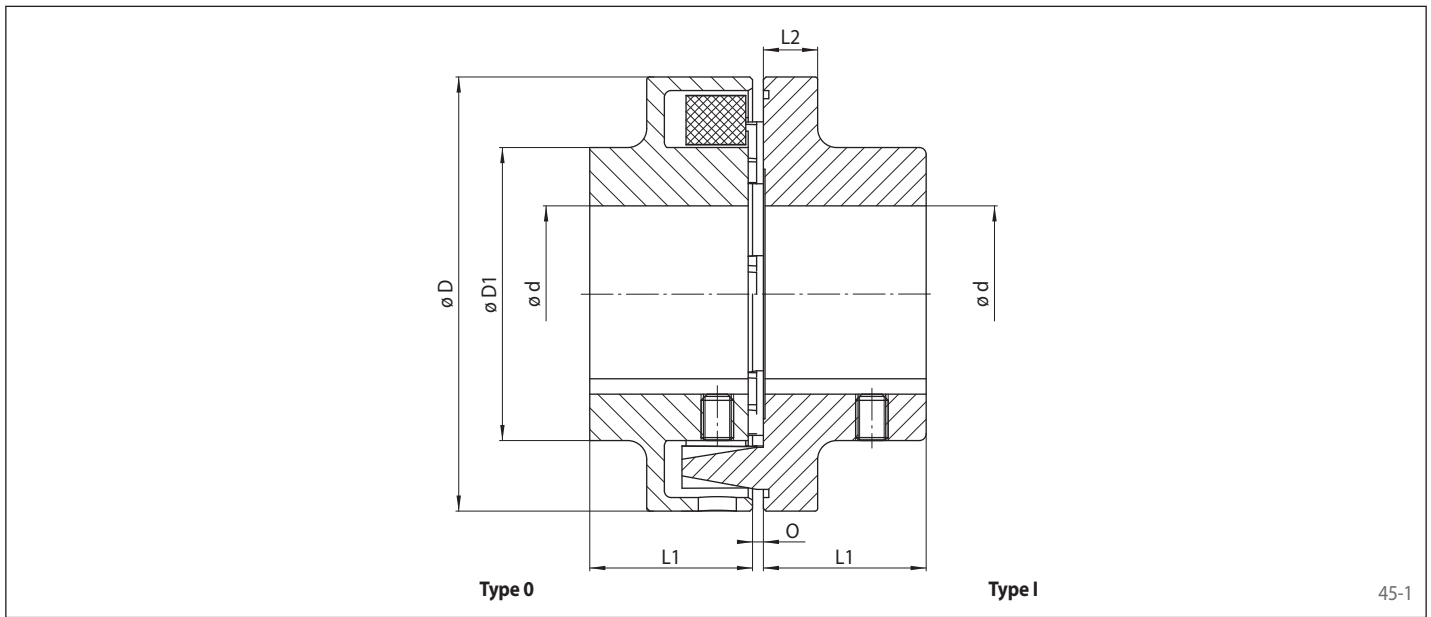

45-1

Coupling size	Max. speed n_{max} min ⁻¹	Moment of inertia with max. bore J_k kgm ²	Pilot bore d^*		Min. bore d^*		Max. bore d^* mm	D mm	D1 mm	L1 mm	L2 mm	O mm	Permissible misalignments			Weight with max. bore kg
			Hub type 0 mm	Hub type I mm	Hub type 0 mm	Hub type I mm							Axial mm	Radial mm	Angular °	
0024	7000	0,0003	8	8	9	9	24	68	46	20	8	2-4	± 1,5	0,4	1	0,63
0028	6000	0,0012	13	8	14	9	30	80	68	30	10	2-4				1,51
0042	5500	0,0027	13	13	14	14	42	95	76	35	12	2-4				2,6
0048	5300	0,0055	13	13	14	14	48	110	86	40	14	2-4				3,9
0055	5100	0,0107	13	13	14	14	55	125	100	50	18	2-4				6,2
0060	4900	0,0140	13	13	14	14	60	140	100	55	20	2-4				6,9
0065	4250	0,0250	13	13	14	14	65	160	108	60	20	2-6				9,4
0075	3800	0,0450	23	13	24	14	75	180	125	70	20	2-6				14,0
0080	3400	0,0800	25	25	26	26	85	200	140	80	24	2-6				20,0
0090	3000	0,1350	35	35	36	36	90	225	150	90	18	2-6				24,5
0100	2750	0,2300	44	44	45	45	100	250	165	100	18	3-8	34,0			

For finish bores, please specify bore diameter hub A and hub B. Tolerance of finish bores H7. Keyways in accordance with DIN 6885, sheet 1. Keyway tolerance JS9.

For vertical installation, please contact RINGSPANN.

See following pages for performance data.

* Bores also available in inch size, see page 68.

Elastic elements

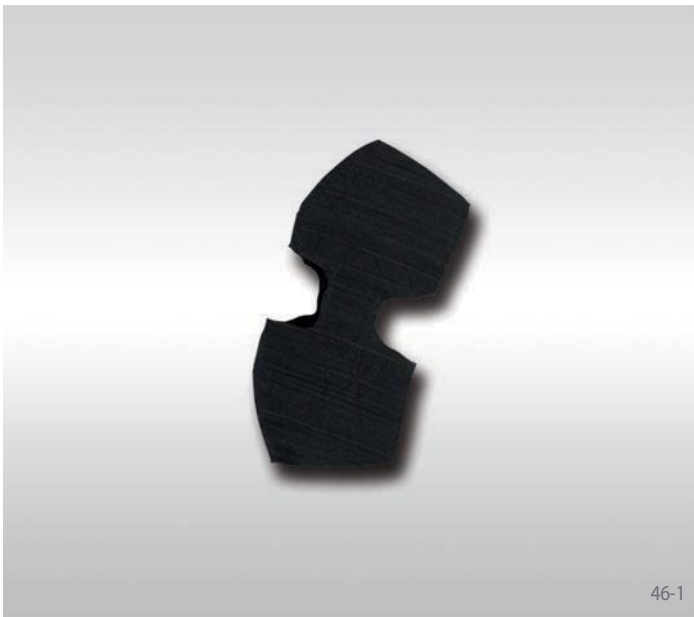

Elastic element NBR 75 Shore-A

Material: Nitrile rubber
 Hardness: 75 ±5 Shore-A
 Temperature range: -40 °C to +100 °C
 Colour: black



Elastic element PU 92 Shore-A

Material: Polyurethane
 Hardness: 92 ±5 Shore-A
 Temperature range: -30 °C to +80 °C
 Colour: orange

Coupling size	Nominal torque T_{KN} Nm	Nominal power at 100 min^{-1} P_{K100} kW	Max. torque T_{Kmax} Nm	Alternating torque T_{KW} Nm	Torsional stiffness $C_{T \text{ dyn}}$ Nm/rad x 10^3			Relative damping ψ at 0,5 T_{KN}
					1,0 T_{KN}	0,5 T_{KN}	0,25 T_{KN}	
0024	34	0,36	102	5	3,0	1,1	0,4	2,2
0028	60	0,63	180	9	8,0	2,7	1,1	
0042	100	1,1	300	15	12,0	4,1	1,7	
0048	160	1,7	480	24	19,0	6,8	2,7	
0055	240	2,5	720	36	28,8	10,4	4,2	
0060	360	3,8	1080	54	42,0	15,0	6,0	
0065	560	5,9	1680	84	77,0	28,0	11,0	
0075	880	9,2	2640	132	145,5	58,1	26,9	
0080	1340	14	4020	201	228,0	91,0	42,0	
0090	2000	21	6000	300	341,8	122,0	63,0	
0100	2800	29	8400	420	472,0	169,0	87,0	

Coupling size	Nominal torque T_{KN} Nm	Nominal power at 100 min^{-1} P_{K100} kW	Max. torque T_{Kmax} Nm	Alternating torque T_{KW} Nm	Torsional stiffness $C_{T \text{ dyn}}$ Nm/rad x 10^3			Relative damping ψ at 0,5 T_{KN}
					1,0 T_{KN}	0,5 T_{KN}	0,25 T_{KN}	
0024	51	0,54	153	8	2,0	1,6	1,4	1,7
0028	90	0,95	270	14	5,0	4,0	3,4	
0042	150	1,65	450	23	7,0	6,1	5,2	
0048	240	2,55	720	36	12,0	10,0	8,6	
0055	360	3,75	1080	54	18,3	15,3	13,2	
0060	540	5,70	1620	81	27,0	22,0	19,0	
0065	840	8,85	2520	126	50,0	41,0	35,0	
0075	1320	13,80	3960	198	99,2	71,5	54,0	
0080	2010	21,00	6030	302	155,0	112,0	84,0	
0090	3000	31,50	9000	450	230,4	182,1	134,4	
0100	4200	43,50	12600	630	318,0	252,0	186,0	

Elastic elements



Elastic element HTrans

Material: Polyurethane
 Hardness: 55 ±2 Shore-D
 Temperature range: -30 °C to +120 °C
 Colour: white

Coupling size	Nominal torque T_{KN} Nm	Nominal power at 100 min^{-1} P_{K100} kW	Max. torque T_{Kmax} Nm	Alternating torque T_{KW} Nm	Torsional stiffness $C_{T \text{ dyn}}$ Nm/rad x 10^3			Relative damping ψ at 0,5 T_{KN}
					1,0 T_{KN}	0,5 T_{KN}	0,25 T_{KN}	
0024	85	0,90	255	13	5	7,8	2,676	0,8
0028	150	1,58	450	23	12	18,9	6,478	
0042	250	2,75	750	38	19	29,0	9,925	
0048	400	4,25	1200	60	31	47,4	16,244	
0055	600	6,25	1800	90	47	49,7	45,314	
0060	900	9,50	2700	135	69	73,0	25,000	
0065	1400	14,75	4200	210	127	133,6	66,560	
0075	2200	23,00	6600	330	248	167,0	130,000	
0080	3350	35,00	10050	503	388	261,0	203,000	
0090	5000	52,50	15000	750	591	472,0	355,000	
0100	7000	72,50	21000	1050	817	652,0	491,000	

Jaw Couplings REK ... DHO

elastic for dynamic applications
with enclosed elastic elements and two piece hub



48-1

Features

- Compensation of axial, radial and angular misalignments
- Adsorbs vibrations
- Progressive torsion spring properties due to primarily pressurised elastic elements
- Fail-safe in the event of the failure of the elastic elements
- Easy replacement of elastic elements without disassembly of the coupling halves
- Maintenance free, no lubrication necessary
- Elastic elements can be replaced without moving the drive
- Declaration of conformity in accordance with ATEX 2014/34/EU possible
- Typical application: Pump drives, ventilator drives, crane trolleys

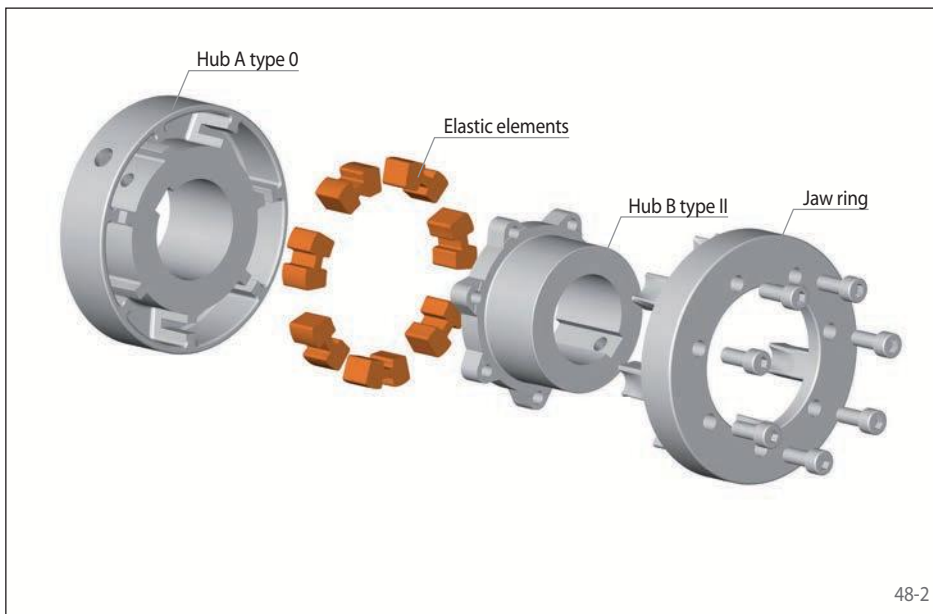

48-2

Order example

Order example	Code
Coupling design	REK
Coupling size	0048
Type	DHO
Material of the hub: • Cast iron	GJL
Hub A, type: • 0, elastomer part	0
Hub A, design: • finish bored with keyway • roughbored	FB VA
Bore diameter hub A	040
Hub B, type: • II, two-part, hub with jaw ring	2
Hub B, design: • finish bored with keyway • roughbored	FB VA
Bore diameter hub B	038
Elastic elements: • NBR 75 Shore-A • PU 92 Shore-A • HTrans	NB75 PU92 HT00



48-3

REK 0048 DHO-GJL-0FB040-2FB038-NB75

Jaw Couplings REK ... DHO

elastic for dynamic applications
with enclosed elastic elements and two piece hub

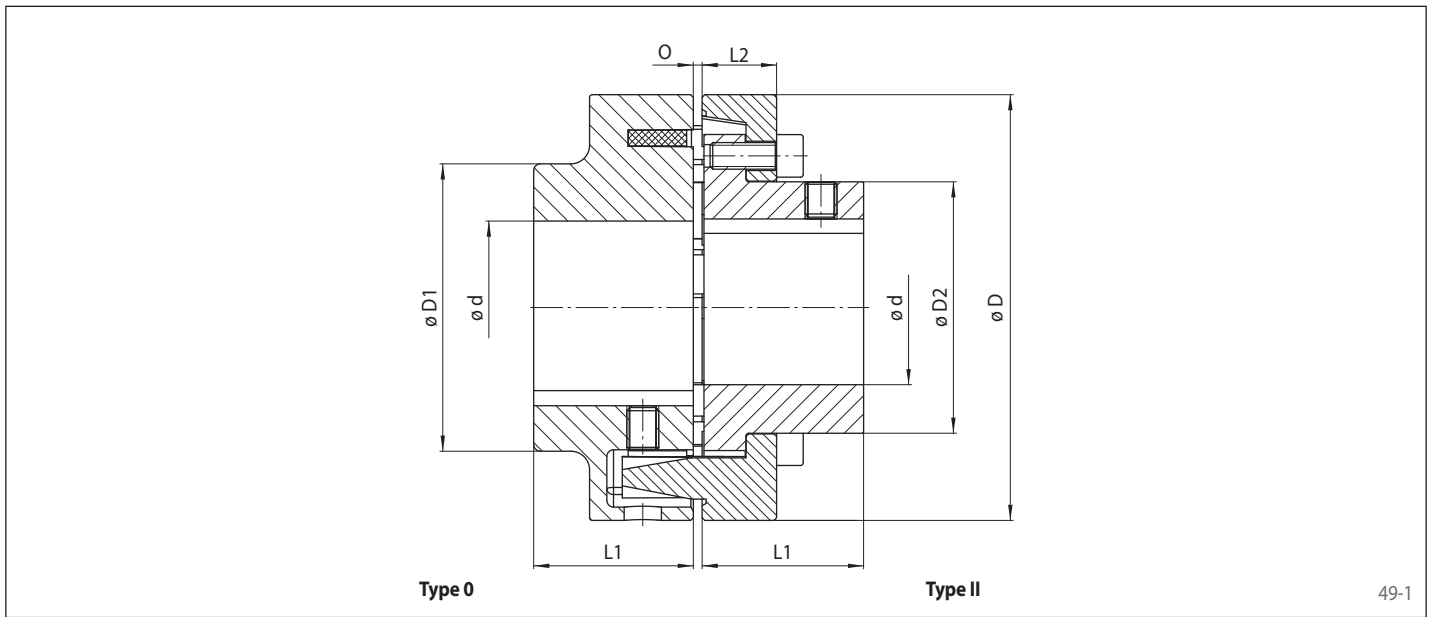

49-1

Coupling size	Max. speed n_{max} min ⁻¹	Moment of inertia with max. bore J_k kgm ²	Pilot bore d^* mm	Min. bore d^* mm	Max. bore d^*		D mm	D1 mm	D2 mm	L1 mm	L2 mm	O mm	Permissible misalignments			Weight with max. bore kg
					Hub type 0 mm	Hub type I mm							Axial mm	Radial mm	Angular °	
0048	5300	0,0047	13	14	48	38	110	86	62	40	20	2-4	± 1,5	0,4	1	3,5
0055	5100	0,0095	13	14	55	45	125	100	75	50	23	2-4				5,6
0060	4900	0,0150	13	14	60	50	140	100	82	55	28	2-4				7,0
0065	4250	0,0280	13	14	65	58	160	108	95	60	28	2-6				9,8
0075	3800	0,0490	23	24	75	65	180	125	108	70	30	2-6				14,2
0080	3400	0,0850	25	26	85	75	200	140	122	80	32	2-6				19,8
0090	3000	0,1500	35	36	90	85	225	150	138	90	38	2-6				27,0
0100	2750	0,2500	44	45	100	95	250	165	155	100	42	3-8				37,0

For finish bores, please specify bore diameter hub A and hub B. Tolerance of finish bores H7. Keyways in accordance with DIN 6885, sheet 1. Keyway tolerance JS9.
For vertical installation, please contact RINGSPANN.
See following pages for performance data.
* Bores also available in inch size, see page 68.

Elastic elements



50-1



50-2

Elastic element NBR 75 Shore-A

Material: Nitrile rubber
 Hardness: 75 ±5 Shore-A
 Temperature range: -40 °C to +100 °C
 Colour: black

Elastic element PU 92 Shore-A

Material: Polyurethane
 Hardness: 92 ±5 Shore-A
 Temperature range: -30 °C to +80 °C
 Colour: orange

Coupling size	Nominal torque T_{KN}	Nominal power at 100 min^{-1} P_{K100}	Max. torque T_{Kmax}	Alter-nating torque T_{KW}	Torsional stiffness $C_{T \text{ dyn}}$ $\text{Nm/rad} \times 10^3$			Relative damping ψ at
					1,0 T_{KN}	0,5 T_{KN}	0,25 T_{KN}	
0048	160	1,70	480	24	19,0	6,8	2,7	2,2
0055	240	2,50	720	36	28,8	10,4	4,2	
0060	360	3,80	1080	54	42,0	15,0	6,0	
0065	560	5,90	1680	84	77,0	28,0	11,0	
0075	880	9,20	2640	132	145,5	58,1	26,9	
0080	1340	14,00	4020	201	228,0	91,0	42,0	
0090	2000	21,00	6000	300	341,8	122,0	63,0	
0100	2800	29,00	8400	420	472,0	169,0	87,0	

Coupling size	Nominal torque T_{KN}	Nominal power at 100 min^{-1} P_{K100}	Max. torque T_{Kmax}	Alter-nating torque T_{KW}	Torsional stiffness $C_{T \text{ dyn}}$ $\text{Nm/rad} \times 10^3$			Relative damping ψ at
					1,0 T_{KN}	0,5 T_{KN}	0,25 T_{KN}	
0048	240	2,55	720	36	12,0	10,0	8,6	1,7
0055	360	3,75	1080	54	18,3	15,3	13,2	
0060	540	5,70	1620	81	27,0	22,0	19,0	
0065	840	8,85	2520	126	50,0	41,0	35,0	
0075	1320	13,80	3960	198	99,2	71,5	54,0	
0080	2010	21,00	6030	302	155,0	112,0	84,0	
0090	3000	31,50	9000	450	230,4	182,1	134,4	
0100	4200	43,50	12600	630	318,0	252,0	186,0	

Elastic elements



51-1

Elastic element HTrans

Material: Polyurethane
 Hardness: 55 ±2 Shore-D
 Temperature range: -30 °C to +120 °C
 Colour: white

Coupling size	Nominal torque T_{KN}	Nominal power at 100 min^{-1} P_{K100}	Max. torque T_{Kmax}	Alternating torque T_{KW}	Torsional stiffness $C_{T \text{ dyn}}$ $\text{Nm/rad} \times 10^3$			Relative damping ψ at
					1,0 T_{KN}	0,5 T_{KN}	0,25 T_{KN}	
0048	400	4,25	1200	60	31	47,4	16,244	0,8
0055	600	6,25	1800	90	47	49,7	45,314	
0060	900	9,50	2700	135	69	73,0	25,000	
0065	1400	14,75	4200	210	127	133,6	66,560	
0075	2200	23,00	6600	330	248	167,0	130,000	
0080	3350	35,00	10050	503	388	261,0	203,000	
0090	5000	52,50	15000	750	591	472,0	355,000	
0100	7000	72,50	21000	1050	817	652,0	491,000	

Jaw Couplings REK ... DGZ

elastic for dynamic applications
with enclosed elastic elements and spacer

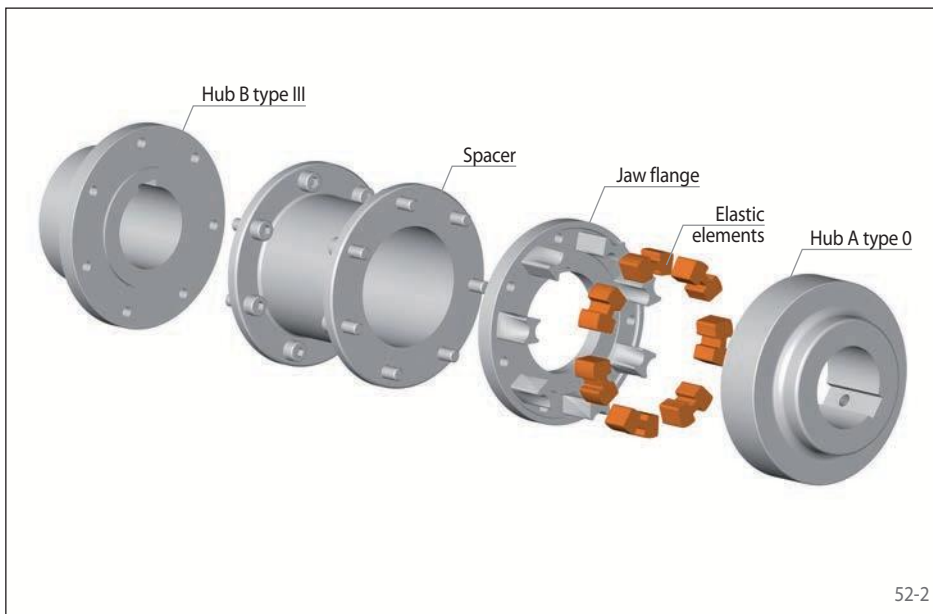

Features

- Compensation of axial, radial and angular misalignments
- Adsorbs vibrations
- Progressive torsion spring properties due to primarily pressurised elastic elements
- Fail-safe in the event of the failure of the elastic elements
- Easy replacement of elastic elements without disassembly of the coupling halves
- Easy separation of the drivetrain through disassembly of the coupling spacer
- Maintenance free, no lubrication necessary
- Declaration of conformity in accordance with ATEX 2014/34/EU possible
- Typical application: Pump drives, ventilator drives, crane trolleys

Order example

	Code
Coupling design	REK
Coupling size	0028
Type	DGZ
Material of the hub: • Cast iron	GJL
Hub A, type: • 0, elastomer part	0
Hub A, design: • finish bored with keyway • roughbored	FB VA
Bore diameter hub A	025
Hub B, type: • III, flange part	3
Hub B, design: • finish bored with keyway • roughbored	FB VA
Bore diameter hub B	032
Elastic elements: • NBR 75 Shore-A • PU 92 Shore-A • HTrans	NB75 PU92 HT00
DBSE L3	0140
↓	
REK 0028 DGZ-GJL-0FB025-3FB032-NB75-0140	

Jaw Couplings REK ... DGZ

elastic for dynamic applications
with enclosed elastic elements and spacer

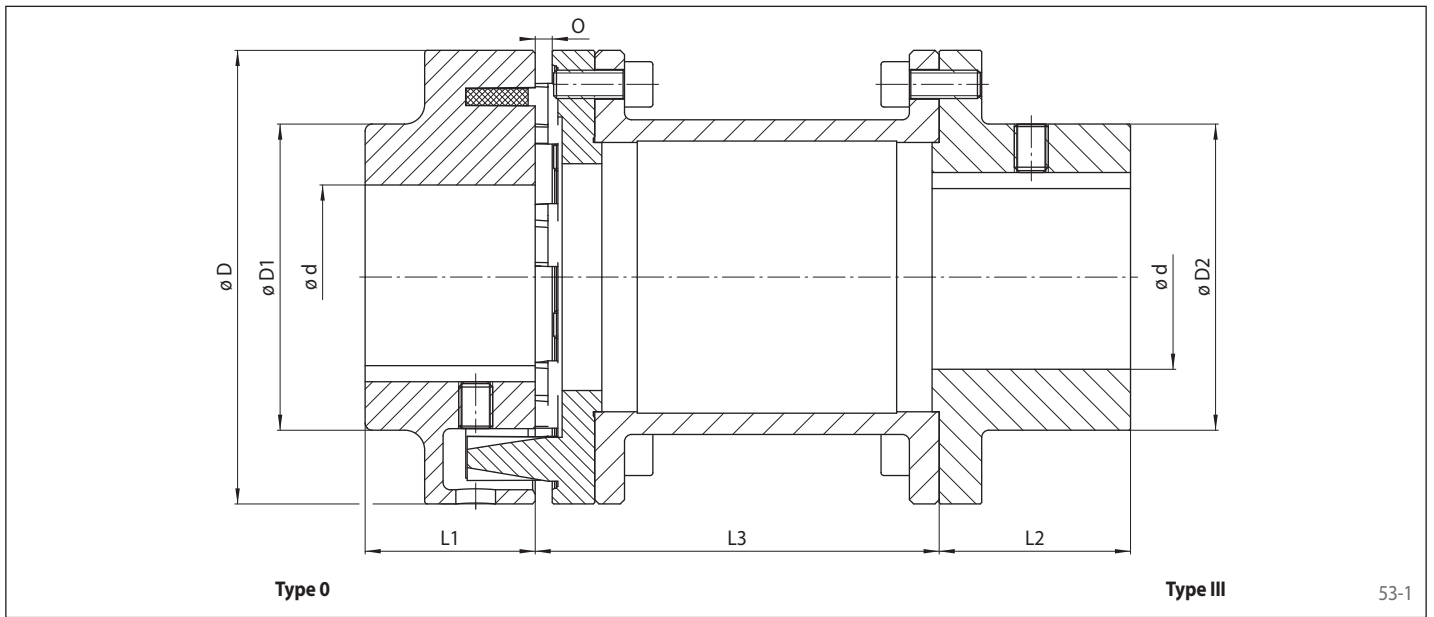

53-1

Coupling size	Max. speed n_{max} min ⁻¹	Moment of inertia with max. bore J_k kgm ²	Pilot bore d^*		Min. bore d^*		Max. bore d^* mm	D mm	D1 mm	D2 mm	L1 mm	L2 mm	L3 mm	O mm	Permissible misalignments			Weight with max. bore kg
			Hub type 0 mm	Hub type I mm	Hub type 0 mm	Hub type I mm									Axial mm	Radial mm	Angular °	
0028	6000	0,0014 0,0015	13	8	14	9	30/32	80	68	55	30	45	100 140	5	± 1,5	0,4	1	2,8 2,9
0042	5500	0,0028 0,0031	13	13	14	14	42	95	76	70	35	45	100 140	5				3,9 4,2
0048	5300	0,0056 0,0060 0,0064	13	13	14	14	48	110	86	80	40	50	100 140 180	5				5,8 6,2 6,6
0055	5100	0,0099 0,0100 0,0110	13	13	14	14	55	125	100	90	50	50	100 140 180	5				8,2 8,7 9,2
0060	4900	0,0190 0,0200	13	13	14	14	60	140	100	100	55	65	140 180	5				11,8 12,3
0065	4250	0,0320 0,0340	13	13	14	14	65	160	108	108	60	70	140 180	6				15,2 16,0
0075	3800	0,0540 0,0580	23	23	24	24	75	180	125	125	70	80	140 180	6				21,0 21,9
0080	3400	0,1000 0,1050 0,1100	25	25	26	26	85	200	140	140	80	90	180 200 250	6				30,3 30,9 32,1
0090	3000	0,1600 0,1700 0,1800	35	35	36	36	90	225	150	150	90	100	180 200 250	6				39,0 39,7 41,5
0100	2750	0,2800 0,3000	44	44	45	45	100	250	165	165	100	110	200 250	8				54,7 56,5

For finish bores, please specify bore diameter hub A and hub B. Tolerance of finish bores H7. Keyways in accordance with DIN 6885, sheet 1. Keyway tolerance JS9.

Upon request: Hub type III in extended design; Spacers for varying DBSEs L3

For vertical installation, please contact RINGSPANN.

See following pages for performance data.

* Bores also available in inch size, see page 68.

Elastic elements



54-1

Elastic element NBR 75 Shore-A

Material: Nitrile rubber
 Hardness: 75 ±5 Shore-A
 Temperature range: -40 °C to +100 °C
 Colour: black



54-2

Elastic element PU 92 Shore-A

Material: Polyurethane
 Hardness: 92 ±5 Shore-A
 Temperature range: -30 °C to +80 °C
 Colour: orange

Coupling size	Nominal torque T_{KN}	Nominal power at 100 min^{-1} P_{K100}	Max. torque T_{Kmax}	Alternating torque T_{KW}	Torsional stiffness $C_{T \text{ dyn}}$ $\text{Nm/rad} \times 10^3$			Relative damping ψ at 0,5 T_{KN}
					1,0 T_{KN}	0,5 T_{KN}	0,25 T_{KN}	
0028	60	0,63	180	9	8,0	2,7	1,1	2,2
0042	100	1,1	300	15	12,0	4,1	1,7	
0048	160	1,7	480	24	19,0	6,8	2,7	
0055	240	2,5	720	36	28,8	10,4	4,2	
0060	360	3,8	1080	54	42,0	15,0	6,0	
0065	560	5,9	1680	84	77,0	28,0	11,0	
0075	880	9,2	2640	132	145,5	58,1	26,9	
0080	1340	14	4020	201	228,0	91,0	42,0	
0090	2000	21	6000	300	341,8	122,0	63,0	
0100	2800	29	8400	420	472,0	169,0	87,0	

Coupling size	Nominal torque T_{KN}	Nominal power at 100 min^{-1} P_{K100}	Max. torque T_{Kmax}	Alternating torque T_{KW}	Torsional stiffness $C_{T \text{ dyn}}$ $\text{Nm/rad} \times 10^3$			Relative damping ψ at 0,5 T_{KN}
					1,0 T_{KN}	0,5 T_{KN}	0,25 T_{KN}	
0028	90	0,95	270	14	5,0	4,0	3,4	1,7
0042	150	1,65	450	23	7,0	6,1	5,2	
0048	240	2,55	720	36	12,0	10,0	8,6	
0055	360	3,75	1080	54	18,3	15,3	13,2	
0060	540	5,70	1620	81	27,0	22,0	19,0	
0065	840	8,85	2520	126	50,0	41,0	35,0	
0075	1320	13,80	3960	198	99,2	71,5	54,0	
0080	2010	21,00	6030	302	155,0	112,0	84,0	
0090	3000	31,50	9000	450	230,4	182,1	134,4	
0100	4200	43,50	12600	630	318,0	252,0	186,0	

Elastic elements



Elastic element HTrans

Material: Polyurethane
 Hardness: 55 ±2 Shore-D
 Temperature range: -30 °C to +120 °C
 Colour: white

Coupling size	Nominal torque T_{KN} Nm	Nominal power at 100 min^{-1} P_{K100} kW	Max. torque T_{Kmax} Nm	Alternating torque T_{KW} Nm	Torsional stiffness $C_{T \text{ dyn}}$ Nm/rad x 10^3			Relative damping ψ at 0,5 T_{KN}
					1,0 T_{KN}	0,5 T_{KN}	0,25 T_{KN}	
0028	150	1,58	450	23	12	18,9	6,478	0,8
0042	250	2,75	750	38	19	29,0	9,925	
0048	400	4,25	1200	60	31	47,4	16,244	
0055	600	6,25	1800	90	47	49,7	45,314	
0060	900	9,50	2700	135	69	73,0	25,000	
0065	1400	14,75	4200	210	127	133,6	66,560	
0075	2200	23,00	6600	330	248	167,0	130,000	
0080	3350	35,00	10050	503	388	261,0	203,000	
0090	5000	52,50	15000	750	591	472,0	355,000	
0100	7000	72,50	21000	1050	817	652,0	491,000	

Jaw Couplings REK ... DCO

elastic for dynamic applications
with curved jaws



Features

- Compensation of axial, radial and angular misalignments
- Adsorbs vibrations
- Progressive torsion spring properties due to primarily pressurised spiders
- Symmetrical design allows for high running speeds without additional balancing
- Fail-safe in the event of the failure of the spider
- Maintenance free, no lubrication necessary
- Declaration of conformity in accordance with ATEX 2014/34/EU possible
- Typical application: Pump drives, ventilator drives, crane trolleys, machine tools, conveyor belts

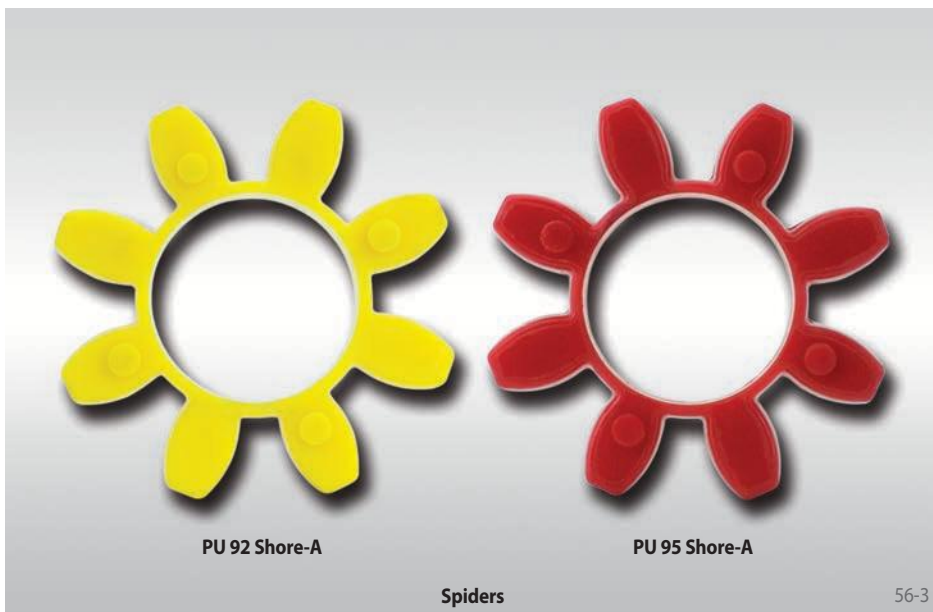
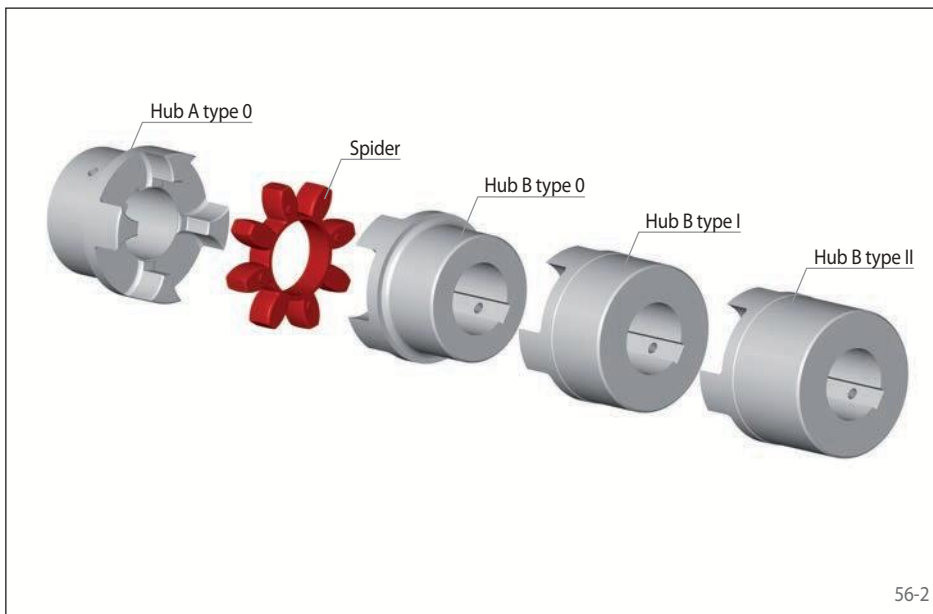

Order example

Order example	Code
Coupling design	REK
Coupling size	0019
Type	DCO
Material of the hub*:	
• Steel	STA
• Cast iron	GJL
• Aluminum	ALU
Hub A, type:	
• 0, standard	0
• I, increased max. bore	1
• II, extended, increased max. bore (from size 0038)	2
Hub A, design:	
• finish bored with keyway	FB
• roughbored	VA
Bore diameter hub A	019
Hub B, type:	
• 0, standard	0
• I, increased max. bore	1
• II, extended, increased max. bore (from size 0038)	2
Hub B, design:	
• finish bored with keyway	FB
• roughbored	VA
Bore diameter hub B	019
Spiders:	
• PU 92 Shore-A	PU92
• PU 95 Shore-A	PU95

REK 0019 DCO-GJL-0FB019-0FB019-PU92

* See opposite table for availability

elastic for dynamic applications
with curved jaws

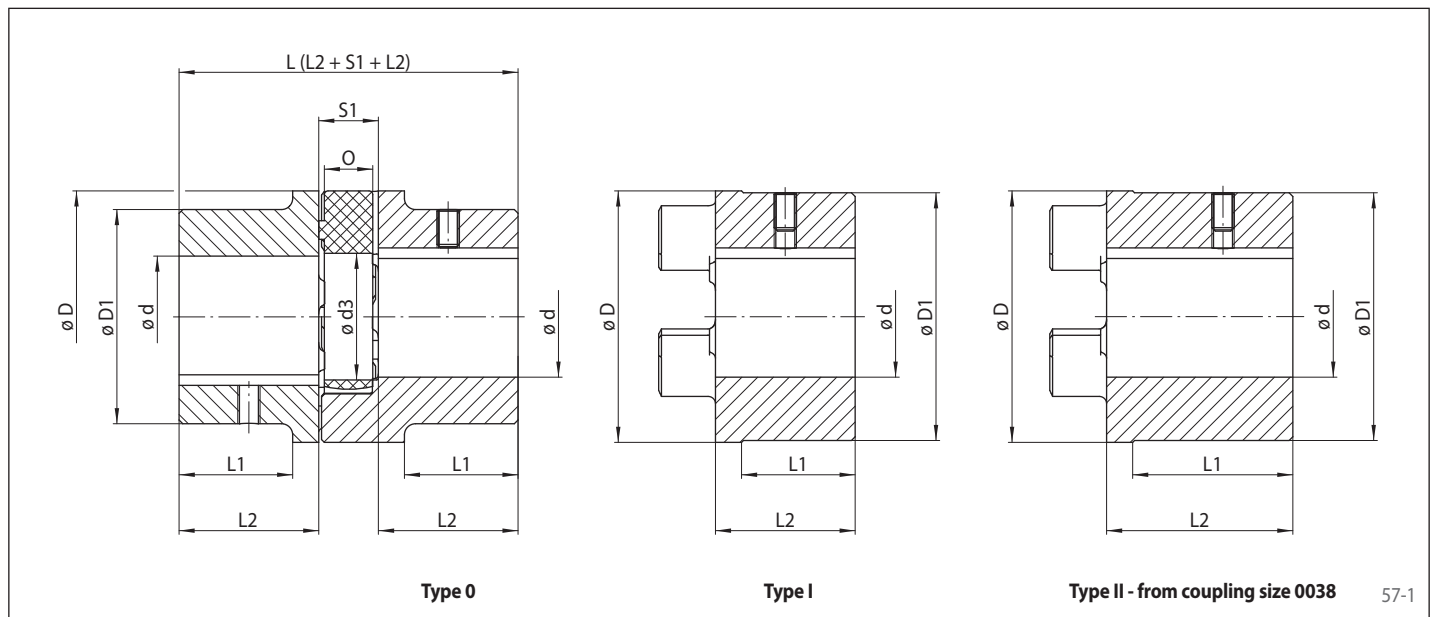

Coupling size	Material of hub			Max. speed n_{max}			Permissible misalignments		
	Steel STA	Cast iron GJL	Aluminum ALU	Steel min^{-1}	Cast iron min^{-1}	Aluminum min^{-1}	Axial mm	Radial mm	Angulaire °
0019	x	-	x	18650	-	19000	1,6	0,15	0,8
0024	x	-	x	13650	-	14000	1,8	0,20	0,8
0028	x	-	x	11600	-	11800	2,0	0,20	0,8
0038	x	x	-	9500	7100	-	2,2	0,25	0,9
0042	x	x	-	8000	6000	-	2,3	0,30	0,9
0048	x	x	-	7200	5600	-	3,0	0,35	1,0
0055	x	x	-	6350	4750	-	3,0	0,35	1,0
0065	x	x	-	5650	4250	-	3,5	0,40	1,0
0075	x	x	-	4750	3550	-	3,5	0,45	1,1
0090	x	x	-	3800	2800	-	4,5	0,50	1,1

Coupling size	Bore d^*										$d3$	D	D1		L1		L2		O	S1
	0		I			II		Hub type 0 I+II		Hub type 0+I II			Hub type 0+I II							
	Pilot bore mm	min. mm	max. mm	Pilot bore mm	min. mm	max. mm	Pilot bore mm	min. mm	max. mm	mm			mm	mm	mm	mm	mm	mm		
0019	-	6	19	-	19	24	-	-	-	18	41	32	41	20	-	25	-	12	16	
0024	-	9	24	-	22	28	-	-	-	27	56	40	56	24	-	30	-	14	18	
0028	-	10	28	-	28	38	-	-	-	30	66	48	66	28	-	35	-	15	20	
0038	10	12	40	36	38	48	10	12	48	38	80	66	78	37	62	45	70	18	24	
0042	12	14	45	40	42	55	12	14	55	46	95	75	94	40	65	50	75	20	26	
0048	13	15	52	46	48	62	13	15	62	51	105	85	104	45	69	56	80	21	28	
0055	18	20	60	53	55	74	18	20	74	60	120	98	118	52	77	65	90	22	30	
0065	20	22	70	63	65	80	20	22	80	68	135	115	133	61	86	75	100	26	35	
0075	28	30	80	73	75	95	28	30	95	80	160	135	158	69	84	85	110	30	40	
0090	38	40	97	88	90	110	38	40	110	100	200	160	198	81	106	100	125	34	45	

For finish bores, please specify bore diameter hub A and hub B. Tolerance of finish bores H7. Keyways in accordance with DIN 6885, sheet 1. Keyway tolerance JS9. See following pages for weights, moments of inertia and performance data.
* Bores also available in inch size, see page 68.

Weights and moments of inertia

Weights in kg with max. bore diameter

Coupling size	Steel			Cast iron			Aluminum		
	Hub type			Hub type			Hub type		
	0	I	II	0	I	II	0	I	II
0019	0,14	0,18	0,26	-	-	-	0,05	0,07	-
0024	0,29	0,37	0,61	-	-	-	0,12	0,16	-
0028	0,45	0,64	1,07	-	-	-	0,19	0,25	-
0038	1,00	1,27	1,90	1,0	1,2	1,8	-	-	-
0042	1,81	1,84	2,76	1,6	1,8	2,3	-	-	-
0048	2,43	2,74	3,80	2,2	2,6	3,1	-	-	-
0055	3,70	3,93	5,23	3,3	3,7	5,1	-	-	-
0065	4,50	5,85	7,58	5,0	5,7	7,3	-	-	-
0075	7,18	9,06	11,50	7,9	9,0	10,5	-	-	-
0090	12,5	17,00	21,15	13,6	18,2	22,3	-	-	-

Moments of inertia [$10^{-3} \times \text{kgm}^2$] with max. bore diameter

Coupling size	Steel			Cast iron			Aluminum		
	Hub type			Hub type			Hub type		
	0	I	II	0	I	II	0	I	II
0019	0,04	0,05	0,07	-	-	-	0,011	0,021	-
0024	0,16	0,21	0,35	-	-	-	0,045	0,085	-
0028	0,34	0,48	0,80	-	-	-	0,100	0,210	-
0038	0,98	1,40	0,03	0,93	1,23	1,86	-	-	-
0042	2,50	2,55	3,82	2,05	2,95	4,27	-	-	-
0048	4,10	5,20	7,21	3,10	4,80	6,70	-	-	-
0055	8,20	10,00	10,00	6,15	8,65	11,85	-	-	-
0065	10,00	20,00	30,00	12,25	13,90	18,15	-	-	-
0075	30,00	40,00	50,00	27,00	30,70	35,75	-	-	-
0090	70,00	120,00	150,00	69,00	91,50	112,50	-	-	-

Spiders

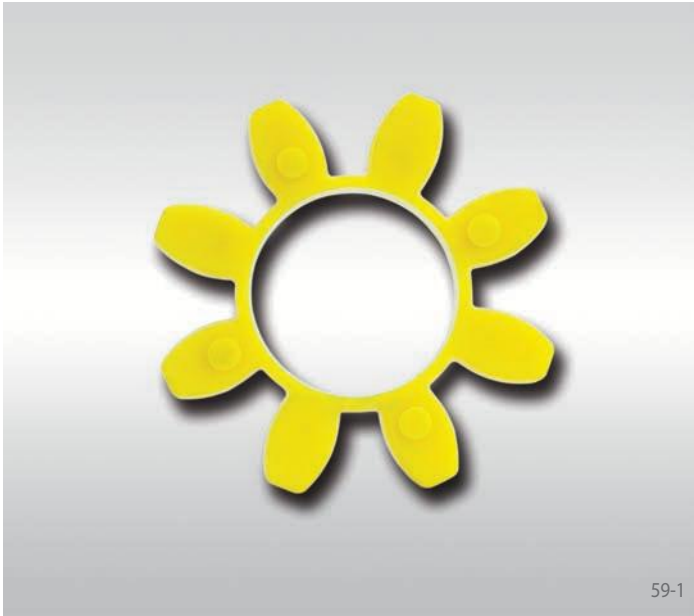

59-1

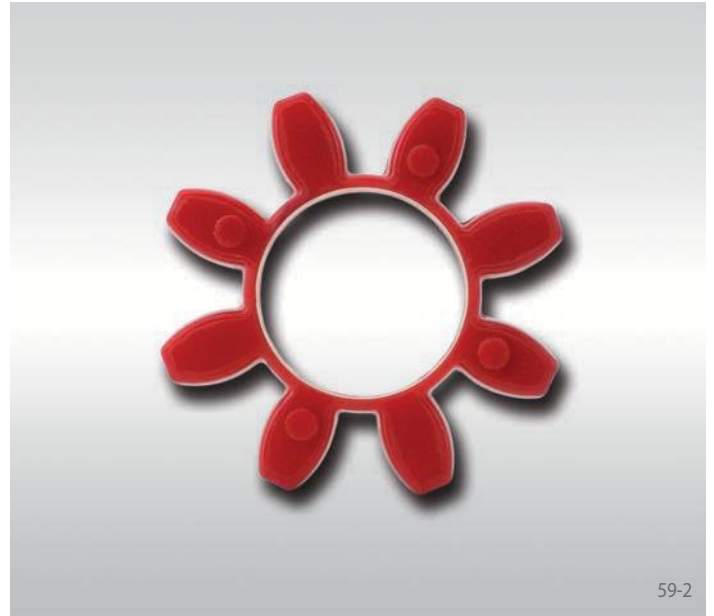

59-2

Spider PU 92 Shore-A

Material: Polyurethane
 Hardness: 92 ±2 Shore-A
 Temperature range: -30 °C to +80 °C
 Colour: yellow

Spider PU 95 Shore-A

Material: Polyurethane
 Hardness: 95 ±2 Shore-A
 Temperature range: -30 °C to +90 °C
 Colour: red

Coupling size	Nominal torque T_{KN} Nm	Nominal power at 100 min^{-1} P_{K100} kW	Max. torque T_{Kmax} Nm	Alter-nating torque T_{KW} Nm	Torsional stiffness $C_{T \text{ dyn}}$ Nm/rad x 10^3			Relative damping ψ at
					1,0	0,5	0,25	
					T_{KN}	T_{KN}	T_{KN}	
0019	9,6	0,1	19	2,5	0,5	0,4	0,2	0,9
0024	33	0,3	69	8,9	2,0	1,3	0,9	
0028	91	1,0	186	24	5,1	3,4	2,3	
0038	181	1,9	372	48	10,2	6,7	4,6	
0042	253	2,6	510	67	14,4	9,4	6,5	
0048	296	3,1	600	79	16,6	10,9	7,5	
0055	392	4,1	800	105	22,9	15,0	10,4	
0065	590	6,3	1220	160	26,0	19,3	13,9	
0075	1220	12,8	2500	326	54,4	40,4	29,0	
0090	2290	24,0	4700	610	86,7	64,0	47,0	

Coupling size	Nominal torque T_{KN} Nm	Nominal power at 100 min^{-1} P_{K100} kW	Max. torque T_{Kmax} Nm	Alter-nating torque T_{KW} Nm	Torsional stiffness $C_{T \text{ dyn}}$ Nm/rad x 10^3			Relative damping ψ at
					1,0	0,5	0,25	
					T_{KN}	T_{KN}	T_{KN}	
0019	16	0,2	32	4,2	1,3	0,9	0,6	0,9
0024	57	0,6	114	15,2	4,8	3,2	2,1	
0028	153	1,6	304	40,0	12,1	8,2	5,4	
0038	310	3,2	610	81,0	24,0	16,2	10,6	
0042	430	4,5	850	111	33,9	22,9	12,3	
0048	500	5,2	990	130	39,2	26,4	16,9	
0055	650	6,8	1300	169	53,9	36,4	25,3	
0065	890	9,4	1780	232	69,3	47,6	33,3	
0075	1830	19,2	3640	474	84,6	58,9	41,4	
0090	3430	36,0	6800	889	150,9	118,5	85,5	

Selection of IEC standard motors

Frame size	A.C. motor 50 Hz		Motor power n = 3 000 min ⁻¹ 2-pole		REK ... DCO	Motor power n = 1 500 min ⁻¹ 4-pole		REK ... DCO	Motor power n = 1 000 min ⁻¹ 6-pole		REK ... DCO	Motor power n = 750 min ⁻¹ 8-pole		REK ... DCO
	Shaft end d x l		Power P _{AN} kW	Torque T _{AN} Nm	Coupling size	Power P _{AN} kW	Torque T _{AN} Nm	Coupling size	Power P _{AN} kW	Torque T _{AN} Nm	Coupling size	Power P _{AN} kW	Torque T _{AN} Nm	Coupling size
	2-pole	4, 6, 8 pole												
56	9 x 20		0,09 0,12	0,32 0,41	0019 Hub type 0	0,06 0,09	0,43 0,64	0019 Hub type 0	0,037 0,045	0,43 0,52	0019 Hub type 0	-	-	-
63	11 x 23		0,18 0,25	0,62 0,86		0,12 0,18	0,88 1,3		0,06 0,09	0,7 1,1		-	-	-
71	14 x 30		0,37 0,55	1,3 1,9		0,25 0,37	1,8 2,5		0,18 0,25	2 2,8		0,09 0,12	1,4 1,8	0019 Hub type 0
80	19 x 40		0,75 1,1	2,5 3,7		0,55 0,75	3,7 5,1		0,37 0,55	3,9 5,8		0,18 0,25	2,5 3,5	0019 Hub type 0
90S	24 x 50		1,5	5	0019 Hub type I	1,1	7,5	0019 Hub type I	0,75	8	0019 Hub type I	0,37	5,3	0019 Hub type I
90L			2,2	7,4		1,5	10		1,1	12		0,55	7,9	
100L	28 x 60		3	9,8	0024 Hub type I	2,2 3	15 20	0024 Hub type I	1,5	15	0024 Hub type I	0,75 1,1	11 16	0024 Hub type I
112M			4	13		4	27		2,2	22		1,5	21	
132S	38 x 80		5,5 7,5	18 25	0028 Hub type I	5,5	36	0028 Hub type I	3	30	0028 Hub type I	2,2	30	0028 Hub type I
132M			-	-		7,5	49		4 5,5	40 55		3	40	
160M	42 x 110		11 15	36 49	0038 Hub type I (II)	11	72	0038 Hub type I (II)	7,5	75	0038 Hub type I (II)	4 5,5	54 74	0038 Hub type I (II)
160L			18,5	60		15	98		11	109		7,5	100	
180M	48 x 110		22	71	0042 Hub type I (II)	18,5	121	0042 Hub type I (II)	-	-	0042 Hub type I (II)	-	-	0042 Hub type I (II)
180L			-	-		22	144		15	148		11	145	
200L	55 x 110		30 37	97 120	0042 Hub type I (II)	30	196	0042 Hub type I (II)	18,5 22	181 215	0042 Hub type I (II)	15	198	0042 Hub type I (II)
225S	55 x 110	60 x 140	-	-		37	240		0048 Hub type I (II)	-		-	0048 Hub type I (II)	
225M			45	140	45	292	30	293		22	290			
250M	60 x 140	65 x 140	55	177	0048 Hub type I (II)	55	356	0055 Hub type I (II)	37	361	0055 Hub type I (II)	30	392	0055 Hub type I (II)
280S	75 x 140		75	241	0055 Hub type I (II)	75	484	0065 Hub type I (II)	45	438	0065 Hub type I (II)	37	483	0065 Hub type I (II)
280M			90	289		90	581		55	535		45	587	
315S	65 x 140	80 x 170	110	353	0065 Hub type I (II)	110	707	0075 Hub type 0	75	727	0075 Hub type 0	55	712	0075 Hub type 0
315M			132	423		132	849		90	873		75	971	
315L			160 200	513 641		160 200	1030 1290		110 132	1070 1280		90 110	1170 1420	
355L	75 x 140	95 x 170	250 315	802 1010	0075 Hub type I (II)	250 315	1600 2020	0090 Hub type 0	160 200 250	1550 1930 2410	0090 Hub type 0	132 160 200	1710 2070 2580	0090 Hub type 0
400			80 x 170	110 x 210		355 400	1140 1280		355 400	2280 2570		315	3040	

During selection, the nominal torque of the coupling at +30 °C was factored in with a start-up factor SZ of 1 and a co-efficient of impact SA/SL of 1. Detailed selection in accordance with the technical information on page 64 et seq.

Standard bores

Coupling size	Material	Hub type	Bore d							
			mm	mm	mm	mm	mm	mm	mm	mm
0019	STA	0	9	11	14	15	18	19	-	-
		I	20	24	-	-	-	-	-	-
	ALU	0	9	11	14	15	18	19	-	-
		I	20	24	-	-	-	-	-	-
0024	STA	0	11	14	15	18	19	20	22	24
		I	28	-	-	-	-	-	-	-
	ALU	0	11	14	15	18	19	20	22	24
		I	28	-	-	-	-	-	-	-
0028	STA	0	14	15	18	19	20	22	24	-
		I	28	32	38	-	-	-	-	-
	ALU	0	14	15	18	19	20	22	24	-
		I	28	32	38	-	-	-	-	-
0038	STA	0	20	24	28	32	38	-	-	-
		I	42	48	-	-	-	-	-	-
	GJL	0	18	19	20	22	24	28	32	38
		I	42	48	-	-	-	-	-	-
0042	STA	0	28	32	38	40	42	-	-	-
		I	48	55	-	-	-	-	-	-
	GJL	0	20	22	24	28	32	38	40	42
		I	48	55	-	-	-	-	-	-
0048	STA	0	32	38	42	48	-	-	-	-
		I	55	60	-	-	-	-	-	-
	GJL	0	24	28	32	38	42	48	-	-
		I	55	60	-	-	-	-	-	-
0055	STA	0	32	38	42	48	55	-	-	-
		I	60	65	-	-	-	-	-	-
	GJL	0	28	32	38	42	48	55	-	-
		I	60	65	-	-	-	-	-	-
0065	STA	0	48	55	60	65	-	-	-	-
		I	75	80	-	-	-	-	-	-
	GJL	0	32	38	42	48	55	60	65	-
		I	75	80	-	-	-	-	-	-
0075	STA	0	48	55	60	65	75	-	-	-
		I	80	85	-	-	-	-	-	-
	GJL	0	42	48	55	60	65	75	-	-
		I	80	-	-	-	-	-	-	-
0090	STA	0	65	75	80	90	-	-	-	-
		I	100	110	-	-	-	-	-	-
	GJL	0	48	55	60	65	75	80	90	-
		I	95	110	-	-	-	-	-	-

Jaw Couplings REK ... ECO

elastic for standard applications
with curved jaws

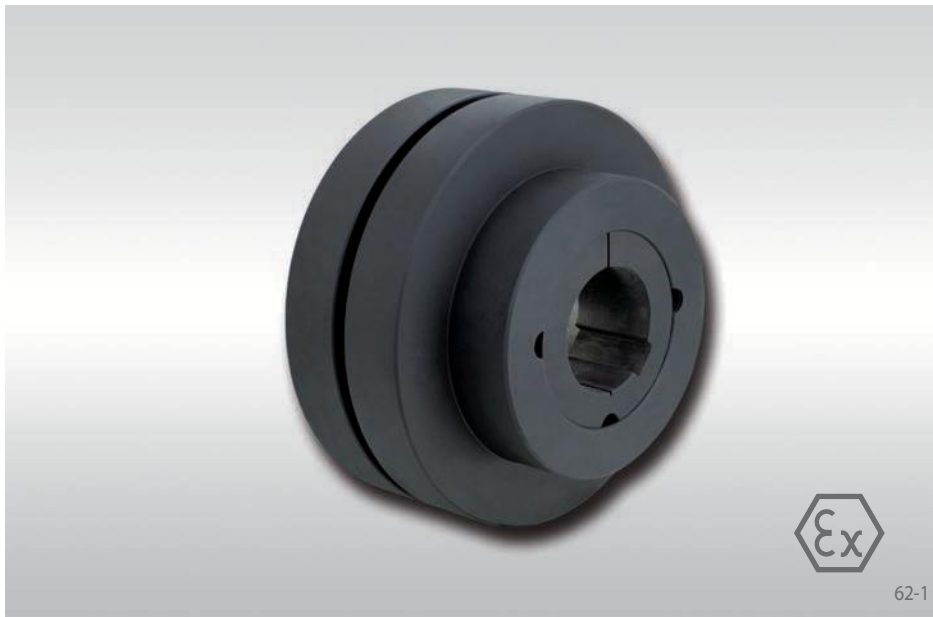

Features

- Compensation of axial, radial and angular misalignments
- Adsorbs vibrations
- Progressive torsion spring properties due to primarily pressurised spiders
- Fail-safe in the event of the failure of the spider
- Maintenance free, no lubrication necessary
- Declaration of conformity in accordance with ATEX 2014/34/EU possible
- Typical application: Pump drives, ventilator drives, crane trolleys, machine tools, conveyor belts

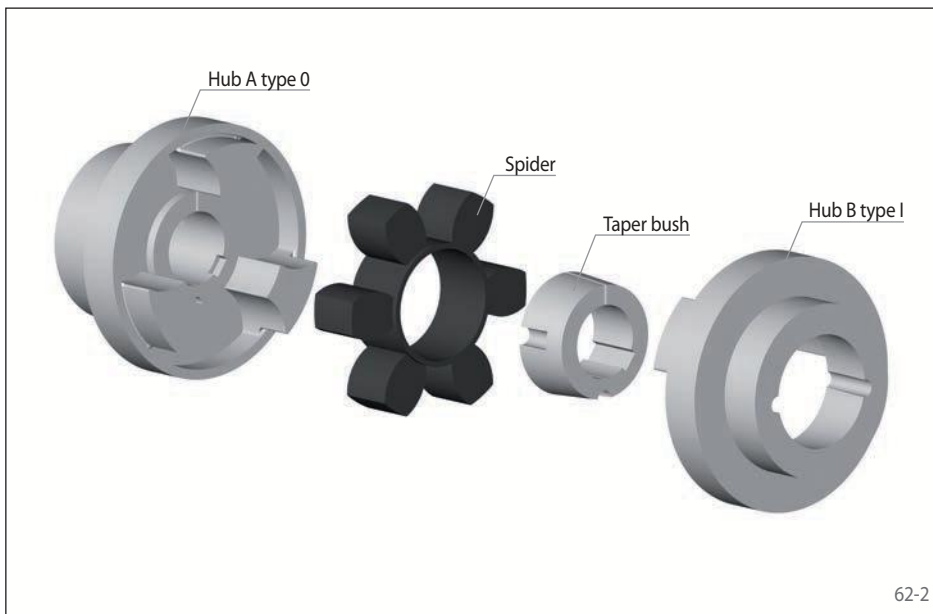

Order example

Order example	Code
Coupling design	REK
Coupling size	0070
Type	ECO
Material of the hub:	GJL
• Cast iron	
Hub A, type:	
• 0, standard	0
• I, shortened for taper bush	1
Hub A, design:	
• roughbored	VA
• finish bored with keyway	FB
• finish bored with taper bush, mounting outside	TA
• finish bored with taper bush, mounting inside	TI
Bore diameter hub A	025
Hub B, type:	
• 0, standard	0
• I, shortened for taper bush	1
Hub B, design:	
• roughbored	VA
• finish bored with keyway	FB
• finish bored with taper bush, mounting outside	TA
• finish bored with taper bush, mounting inside	TI
Bore diameter hub B	032
Spider:	
NBR 80 Shore-A	NB80
REK 0070 ECO-GJL-0FB025-0FB032-NB80	

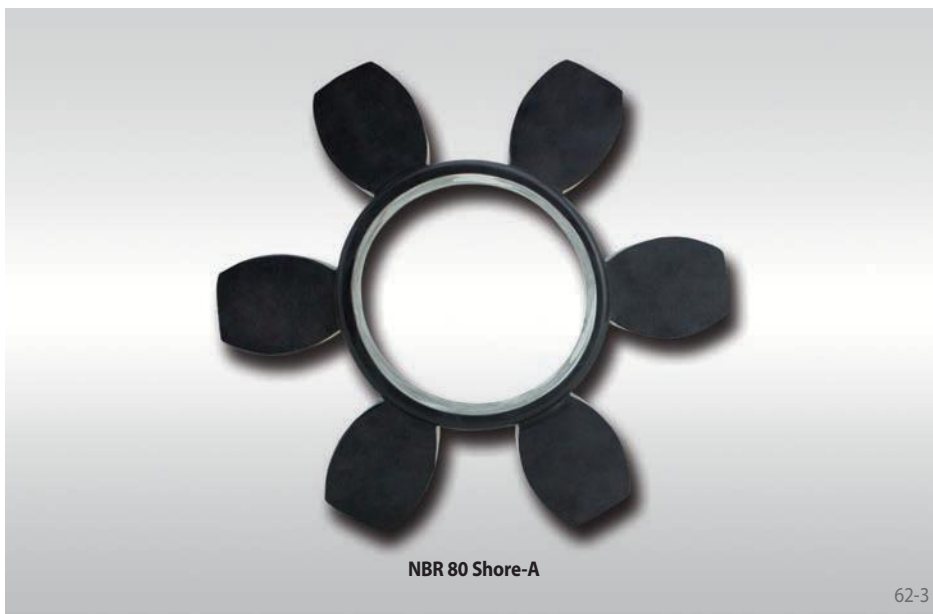

elastic for standard applications
with curved jaws

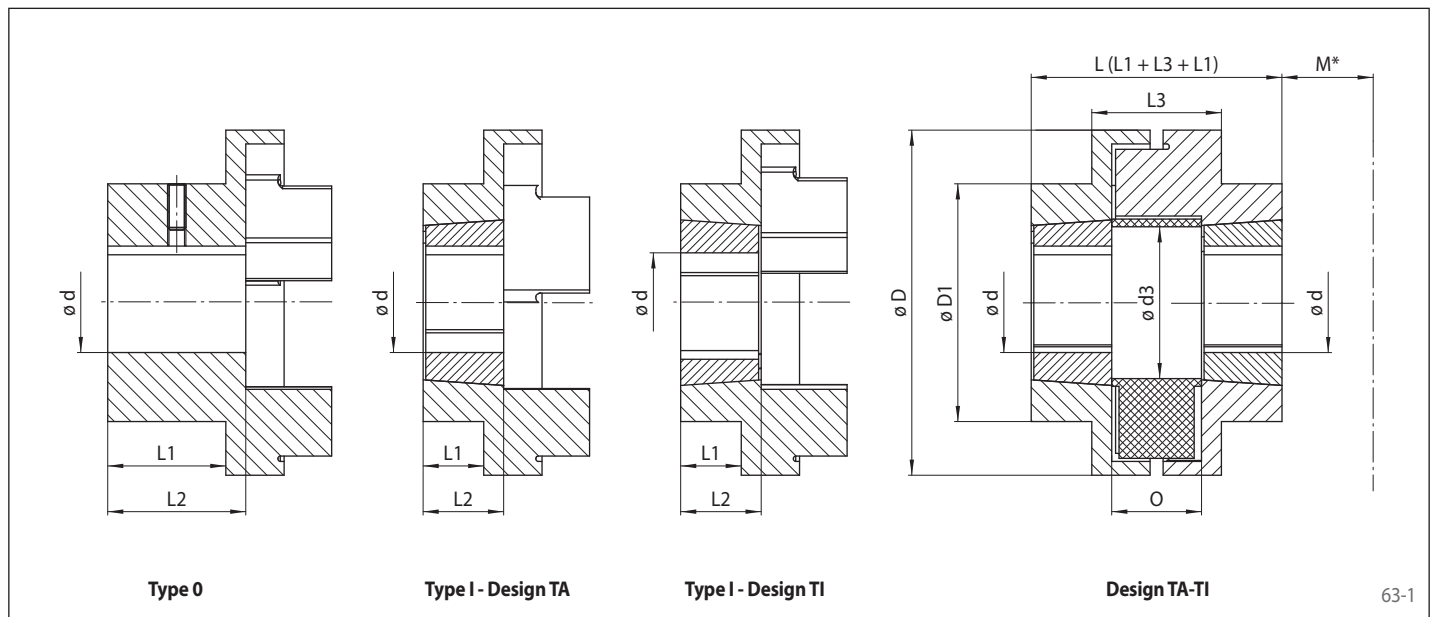

Coupling size	Nominal torque T_{KN}	Nominal power at 100 min^{-1} P_{K100}	Max. torque T_{Kmax}	Max. speed n_{max}	Torsional stiffness C_W	Moment of inertia J_k	Permissible misalignments		
							Axial mm	Radial mm	Angular °
0070	31	0,33	72	8300	584,42	0,0003	+0,20	0,3	1
0090	80	0,84	180	6740	1461,04	0,0010	+0,49	0,3	
0110	160	1,68	360	5110	2750,20	0,0030	+0,61	0,3	
0130	315	3,30	720	4400	4812,85	0,0060	+0,79	0,4	
0150	600	6,28	1500	3820	10084,06	0,0100	+0,92	0,4	
0180	950	9,95	2350	3180	13750,99	0,0220	+1,09	0,4	
0230	2000	20,94	5000	2540	19251,38	0,0650	+1,32	0,5	
0280	3150	32,98	7200	2080	55003,95	0,1910	+1,70	0,5	

Moment of inertia refer to the design with taper bush with medium bore diameter.

Coupling size	Pilot bore d^*	Hub type 0 - Standard				Hub type I - Design TA and TI				D	D1	d3	L3	M**	O	Weight	
		Bore d^*		L1	L2	Taper bush size	Bore d^*		L1								L2
		min. mm	max. mm				min. mm	max. mm									
0070	8	10	32	21,0	26	1008	10	25	19,0	24,0	69	60	31	28,0	29	17,5	1,1
0090	8	10	42	26,0	32	1108	10	28	18,0	24,0	85	65	32	34,5	29	22,5	1,0
0110	8	10	55	37,0	45	1610	14	42	19,0	27,0	112	100	45	45,0	38	29,0	5,0
0130	16	20	60	46,0	55	1610	14	42	17,5	26,5	130	105	50	54,0	38	36,0	8,0
0150	16	20	70	50,0	60	2012	14	50	24,0	34,0	150	115	62	60,0	42	40,0	11,7
0180	35	30	80	58,0	70	2517	16	60	35,0	47,0	180	125	77	73,0	48	49,0	18,2
0230	35	40	100	77,0	90	3020	24	75	39,5	52,5	225	155	99	84,5	55	58,5	35,0
0280	45	50	115	88,5	105	3535	35	90	74,0	90,5	275	185	118	107,5	67	74,5	66,5

For finish bores, please specify bore diameter hub A and hub B. Tolerance of finish bores H7. Keyways in accordance with DIN 6885, sheet 1. Keyway tolerance JS9.

The weight refer to the design with taper bush with medium bore diameter.

See page 67 for dimensions of taper bushes.

For vertical installation, please contact RINGSPANN.

* Bores also available in inch size, see page 68.

** Minimum distance to install and disassemble the taper bush.

Elastomer element	Material	Hardness	Temperature range °C	Colour
NBR 80 Shore-A	Nitrile rubber	80 ±5 Shore-A	-40 to +100	black

Coupling selection

The selection of the coupling is carried out in accordance with DIN 740 part 2 or with the help of service factors due to experience (see table: Assignment of the selection method to coupling types). The coupling must be designed in

such a manner that the permissible coupling stress is not exceeded in any operating state. A comparison of the occurring stresses with the permissible coupling parameters must be carried out for this purpose.

In addition to the selection of the coupling, the load-bearing capacity of the selected Shaft-Hub-Connection must be examined by the customer.

Assignment of the selection method to coupling types

Torsionally Rigid Shaft Couplings	Selection according to DIN 740 part 2	Selection with service factors
Gear Couplings		
RDZ ... DTO		●
RDZ ... DFO		●
RDZ ... EEO	●	
Torsionally Rigid, Initially Elastic Shaft Couplings	Selection according to DIN 740 part 2	Selection with service factors
Grid Couplings		
RES ... EYO		●
RES ... ETO		●
Torsionally Rigid Shaft Couplings	Selection according to DIN 740 part 2	Selection with service factors
Disc Couplings		
RDL ... DSO		●
RDL ... DSZ		●
RDL ... DSA		●
Flexible Couplings		
RDA ... ESO, Design RDA ... ESO-...-0...		●
RDA ... ESO, Design RDA ... ESO-STA-1KA ...		●
RDA ... ESO, Design RDA ... ESO-GJS-2PE ...		●
Elastic Shaft Couplings	Selection according to DIN 740 part 2	Selection with service factors
Pin and Bush Couplings		
REB ... DCO	●	
Jaw Couplings		
REK ... DQO	●	
REK ... DGO	●	
REK ... DHO	●	
REK ... DGZ	●	
REK ... DCO	●	
REK ... ECO	●	

Formula symbols

J_A = Moment of inertia of the drive side [kgm²]
 J_L = Moment of inertia of the load side [kgm²]
 M_A = Rotational inertia factor of the drive side
 M_L = Rotational inertia factor of the load side
 N = Speed of the machine [min⁻¹]
 P_{AN} = Nominal power of the drive [kW]

P_{LN} = Power consumption of driven machine [kW]
 P_N = Nominal power $P_N = P_{AN}$ or P_{LN} [kW]
 S_A, S_L = Co-efficient of impact
 S_B = Service factor
 S_t = Temperature factor
 S_Z = Start-up factor
 T_{AS} = Peak torque of the drive side [Nm]
 T_{Kmax} = Maximum permissible torque of the coupling [Nm]

T_{KN} = Nominal torque of the coupling [Nm]
 T_{KW} = Alternating torque of the coupling [Nm]
 T_{LS} = Peak torque of the load side [Nm]
 T_N = Nominal torque of the machine [Nm]
 T_S = Peak torque of the machine [Nm]
 T_W = Alternating torque of the machine [Nm]

Design as per DIN 740 part 2

a) Drives without periodic stress due to torsional vibration

For drives without periodic stress due to torsional vibration such as centrifugal pumps, ventilators, screw compressors and similar applications, the nominal torque of the machine T_N may not exceed the nominal torque of coupling T_{KN} .

1. Stress from the nominal torque of the machine

The nominal torque of the machine T_N results from:

$$T_N = 9550 \cdot \frac{P_N}{n}$$

With consideration of the temperature factor S_t , the nominal torque of coupling T_{KN} must be at least as high as the nominal torque of machine T_N .

$$T_{KN} \geq T_N \cdot S_t$$

2. Additional stress through torque shocks

If shock loads occur often in the machine, the additional peak torque T_S and the shock frequency S_Z must be factored in.

Depending on the shock type, the shock direction and the mass distribution, the peak torque T_S can be calculated as follows:

Drive-side shock:

$$T_S = T_{AS} \cdot M_A \cdot S_A$$

Load-side shock:

$$T_S = T_{LS} \cdot M_L \cdot S_L$$

with

$$M_A = \frac{J_L}{J_A + J_L} \quad M_L = \frac{J_A}{J_A + J_L}$$

The maximum permissible torque of coupling T_{Kmax} must be larger than the sum of peak torque T_S multiplied by the start-up factor S_Z and the nominal torque of the machine T_N with consideration of the temperature factor S_t .

$$T_{Kmax} \geq T_S \cdot S_Z \cdot S_t + T_N \cdot S_t$$

For drives with A.C. motors and large, load-side masses, the start-up peak torque should be calculated with the help of suitable simulation methods.

b) Drives with periodic stress due to torsional vibration

Drives where torsional vibration can occur (e.g. diesel motors, piston compressors, piston pumps, etc.), the torques seen by the coupling can be determined through a rotational vibration analysis of the entire system. This requires among other things knowledge of the rotating masses, the rotational rigidity and all the excitation movements that occur in the system. In many cases, a vibrational calculation is too time consuming or you may not have all the necessary data in the configuration phase available. In this case, an approximate design can be carried out on the basis of the following criteria:

1. Stress through the unit torque

Using the temperature factor S_t , the nominal torque of the coupling T_{KN} must be at least as high as the nominal torque of the machine T_N .

$$T_{KN} \geq T_N \cdot S_t$$

2. Stress through an alternating torque

The periodic alternating torque of the machine T_W may at operating speed and using the temperature factor S_t may not exceed the permissible alternating torque of the coupling T_{KW} .

$$T_{KW} \geq T_W \cdot S_t$$

3. Stress when passing through harmonic resonance

If the harmonic resonance is passed through during operation, the hereby occurring peak torque T_S with consideration of the ambient temperature S_t may not exceed the maximum permissible torque of coupling T_{Kmax} .

$$T_{Kmax} \geq T_S \cdot S_t$$

Start-up factor S_Z

Start-up frequency/h	100	200	400	800
S_Z	1,0	1,2	1,4	1,6

Co-efficient of impact S_A/S_L

	S_A/S_L
light impacts	1,5
medium impacts	1,8
heavy impacts	2,5

Temperature factor S_t

Ambient temperature t_A	$\leq -30^\circ\text{C}$	$-30^\circ\text{C} < t_A \leq +30^\circ\text{C}$	$+30^\circ\text{C} < t_A \leq +40^\circ\text{C}$	$+40^\circ\text{C} < t_A \leq +50^\circ\text{C}$	$+50^\circ\text{C} < t_A \leq +60^\circ\text{C}$	$+60^\circ\text{C} < t_A \leq +70^\circ\text{C}$	$t_A \leq +80^\circ\text{C}$
PU 92 Shore-A	-	1	1,2	1,3	1,4	1,55	1,8
PU 95 Shore-A							
HTrans							
NBR 92 Shore-A	-	1	1	1	1	1	1
NBR 80 Shore-A							
NBR 75 Shore-A							
NR 80 Shore-A	1,1	1	1	1	1	1	1
PA 6.6	-	1	1	1	1	1,2	1,4

Design with service factors

The permissible nominal torque of coupling T_{KN} must be at least as high as the nominal torque of the machine T_N with consideration of the operating conditions (service factor S_B).

The nominal torque of the machine T_N results is determined as follows

$$T_N = 9550 \cdot \frac{P_N}{n}$$

$$T_{KN} \geq T_N \cdot S_B$$

Service factor S_B

Type of the driven machine	Driven by			
	Transmissions, electric motors	Combustion engines with 4 and 6 cylinders	Combustion engines with 2 and 3 cylinders, single-cylinder steam engines	Single-cylinder combustion engines
Transmissions, small generators, small ventilators, rotary fans	1,5	1,7	1,9	2,2
Small lifts, larger ventilators, light machines for metal, wood and textile processing, light transport belts	1,8	2,0	2,2	2,5
Goods lifts, conveyor belts, overhead tracks, mixers, textile machines with large masses	2,0	2,2	2,4	2,7
Presses, cutters, punches, piston pumps, calenders, hammer mills	2,5	2,7	2,9	3,2
Stone crushers, heavy roller conveyors, piston compressors and piston pumps without a flywheel, rolling mills for metals	3,0	3,2	3,4	3,7
Rotary presses, mixers for highly-viscous media, propellers	3,0	3,5	4,3	5,0

Dimensions of taper bushes

Size	Screw tightening torque Nm	Clamping screws details			Largest outside diameter mm	Weight approx. kg	Bore*				Bore**	
		Number	Wrench size mm	Wrench size inch			min. mm	max. mm	min. inch	max. inch	max. mm	max. inch
1008	5,6	2	3	1/4	35	0,1	10	22	3/8	7/8	25	1
1108	5,6	2	3	1/4	38	0,1	10	25	3/8	1	28	1 1/8
1210	20	2	5	3/8	47,5	0,2	12	32	1/2	1 1/4	-	-
1215	20	2	5	3/8	47,5	0,3	12	30	1/2	1 1/8	-	-
1610	20	2	5	3/8	57	0,3	14	35	1/2	1 3/8	-	-
1615	20	2	5	3/8	57	0,5	14	38	1/2	1 1/2	42	1 1/2
2012	30	2	6	7/16	70	0,7	14	45	1/2	1 3/4	-	-
2017	30	2	6	7/16	70	1,1	14	45	1/2	1 3/4	-	-
2517	50	2	6	1/2	85,5	1,5	16	60	5/8	2 1/2	-	-
2525	50	2	6	1/2	85,5	2,1	16	60	5/8	2 3/8	-	-
3020	90	2	8	5/8	108	2,7	24	75	1	3	-	-
3030	90	2	8	5/8	108	3,6	24	75	1	3	-	-
3525	113	3	10	1/2	127	3,8	35	90	1 3/8	3 1/2	100	4
3535	113	3	10	1/2	127	5	35	90	1 3/8	3 1/2	-	-
4030	170	3	12	5/8	146	5,6	40	100	1 1/2	4	115	4 1/2
4040	170	3	12	5/8	146	7,7	40	100	1 3/4	4	-	-
4535	190	3	14	3/4	162	7,5	55	110	2 1/4	4 1/4	-	-
4545	190	3	14	3/4	162	10	55	110	2 1/4	4 1/4	-	-
5050	270	3	14	7/8	177,5	14	70	125	2 3/4	5	-	-

* with keyway in accordance with DIN 6885/1 or ANSI ANSI B17.1-1967 (R1998) rectangular

** with keyway in accordance with DIN 6885/3 or ANSI ANSI B17.1-1967 (R1998) square

Numeric value in order code for bore in imperial dimension

Bore tolerance: H7, keyway: design according to DIN 6558/1, keyway tolerance JS9

Bore, whole number	Bore, fractional															
	0	1/16"	1/8"	3/16"	1/4"	5/16"	3/8"	7/16"	1/2"	9/16"	5/8"	11/16"	3/4"	13/16"	7/8"	15/16"
0"	BAA	BAB	BAC	BAD	BAE	BAF	BAG	BAH	BAI	BAJ	BAK	BAL	vBAM	BAN	BAO	BAP
1"	BBA	BBB	BBC	BBD	BBE	BBF	BBG	BBH	BBI	BBJ	BBK	BBL	BBM	BBN	BBO	BBP
2"	BCA	BCB	BCC	BCD	BCE	BCF	BCG	BCH	BCI	BCJ	BCK	BCL	BCM	BAN	BCO	BCP
3"	BDA	BDB	BDC	BDD	BDE	BDF	BDG	BDH	BDI	BDJ	BDK	BDL	BDM	BND	BDO	BDP
4"	BEA	BEB	BEC	BED	BEE	BEF	BEG	BEH	BEI	BEJ	BEK	BEL	BEM	BEN	BEO	BEP
5"	BFA	BFB	BFC	BFD	BFE	BFF	BFG	BFH	BFI	BFJ	BFK	BFL	BFM	BFN	BFO	BFP
6"	BGA	BGB	BGC	BGD	BGE	BGF	BGG	BGH	BGI	BGJ	BGK	BGL	BGM	BGN	BGO	BGP
7"	BHA	BHB	BHC	BHD	BHE	BHF	BHG	BHH	BHI	BHJ	BHK	BHL	BHM	BHN	BHO	BHP
8"	BIA	BIB	BIC	BID	BIE	BIF	BIG	BIH	BII	BIJ	BIK	BIL	BIM	BIN	BIO	BIP
9"	BJA	BJB	BJC	BJD	BJE	BJF	BJG	BJH	BJI	BJJ	BJK	BJL	BJM	BJN	BJO	BJP
10"	BKA	BKB	BKC	BKD	BKE	BKF	BKG	BKH	BKI	BKJ	BKK	BKL	BKM	BKN	BKO	BKP
11"	BLA	BLB	BLC	BLD	BLE	BLF	BLG	BLH	BLI	BLJ	BLK	BLL	BLM	BLN	BLO	BLP
12"	BMA	BMB	BMC	BMD	BME	BMF	BMG	BMH	BMI	BMJ	BMK	BML	BMM	BMN	BMO	BMP
13"	BNA	BNB	BNC	BND	BNE	BNF	BNG	BNH	BNI	BNJ	BNK	BNL	BNM	BNN	BNO	BNP
14"	BOA	BOB	BOC	BOD	BOE	BOF	BOG	BOH	BOI	BOJ	BOK	BOL	BOM	BON	BOO	BOP
15"	BPA	BPB	BPC	BPD	BPE	BPF	BPG	BPH	BPI	BPJ	BPK	BPL	BPM	BPN	BPO	BPP
16"	BQA	BQB	BQC	BQD	BQE	BQF	BQG	BQH	BQI	BQJ	BQK	BQL	BQM	BQN	BQO	BQP
17"	BRA	BRB	BRC	BRD	BRE	BRF	BRG	BRH	BRI	BRJ	BRK	BRL	BRM	BRN	BRO	BRP
18"	BSA	BSB	BSC	BSD	BSE	BSF	BSG	BSH	BSI	BSJ	BSK	BSL	BSM	BSN	BSO	BSP
19"	BTA	BTB	BTC	BTD	BTE	BTF	BTG	BTH	BTI	BTJ	BTK	BTL	BTM	BTN	BTO	BTP
20"	BUA	BUB	BUC	BUD	BUE	BUF	BUG	BUH	BUI	BUJ	BUK	BUL	BUM	BUN	BUO	BUP
21"	BVA	BVB	BVC	BVD	BVE	BVF	BVG	BVH	BVI	BVJ	BVK	BVL	BVM	BVN	BVO	BVP
22"	BWA	BWB	BWC	BWD	BWE	BWF	BWG	BWH	BWI	BWJ	BWK	BWL	BWM	BWN	BWO	BWP
23"	BXA	BXB	BXC	BXD	BXE	BXF	BXG	BXH	BXI	BXJ	BXK	BXL	BXM	BXN	BXO	BXP

Bore tolerance: Interference fit according to AGMA; keyway: keyway geometry and tolerance according to AGMA

Bore, whole number	Bore, fractional															
	0	1/16"	1/8"	3/16"	1/4"	5/16"	3/8"	7/16"	1/2"	9/16"	5/8"	11/16"	3/4"	13/16"	7/8"	15/16"
0"	AAA	AAB	AAC	AAD	AAE	AAF	AAG	AAH	AAI	AAJ	AAK	AAL	AAM	AAN	AAO	AAP
1"	ABA	ABB	ABC	ABD	ABE	ABF	ABG	ABH	ABI	ABJ	ABK	ABL	ABM	ABN	ABO	ABP
2"	ACA	ACB	ACC	ACD	ACE	ACF	ACG	ACH	ACI	ACJ	ACK	ACL	ACM	ACN	ACO	ACP
3"	ADA	ADB	ADC	ADD	ADE	ADF	ADG	ADH	ADI	ADJ	ADK	ADL	ADM	ADN	ADO	ADP
4"	AEA	AEB	AEC	AED	AEE	AEF	AEG	AEH	AEI	AEJ	AEK	AEL	AEM	AEN	AEO	AEP
5"	AFA	AFB	AFC	AFD	AFE	AFF	AFG	AFH	AFI	AFJ	AFK	AFL	AFM	AFN	AFO	AFP
6"	AGA	AGB	AGC	AGD	AGE	AGF	AGG	AGH	AGI	AGJ	AGK	AGL	AGM	AGN	AGO	AGP
7"	AHA	AHB	AHC	AHD	AHE	AHF	AHG	AHH	AHI	AHJ	AHK	AHL	AHM	AHN	AHO	AHP
8"	AIA	AIB	AIC	AID	AIE	AIF	AIG	AIH	AII	AIJ	AIK	AIL	AIM	AIN	AIO	AIP
9"	AJA	AJB	AJC	AJD	AJE	AJF	AJG	AJH	AJI	AJJ	AJK	AJL	AJM	AJN	AJO	AJP
10"	AKA	AKB	AKC	AKD	AKE	AKF	AKG	AKH	AKI	AKJ	AKK	AKL	AKM	AKN	AKO	AKP
11"	ALA	ALB	ALC	ALD	ALE	ALF	ALG	ALH	ALI	ALJ	ALK	ALL	ALM	ALN	ALO	ALP
12"	AMA	AMB	AMC	AMD	AME	AMF	AMG	AMH	AMI	AMJ	AMK	AML	AMM	AMN	AMO	AMP
13"	ANA	ANB	ANC	AND	ANE	ANF	ANG	ANH	ANI	ANJ	ANK	ANL	ANM	ANN	ANO	ANP
14"	AOA	AOB	AOC	AOD	AOE	AOF	AOG	AOH	AOI	AOJ	AOK	AOL	AOM	AON	AOO	AOP
15"	APA	APB	APC	APD	APE	APF	APG	APH	API	APJ	APK	APL	APM	APN	APO	APP
16"	AQA	AQB	AQC	AQD	AQE	AQF	AQG	AQH	AQI	AQJ	AQK	AQL	AQM	AQN	AQO	AQP
17"	ARA	ARB	ARC	ARD	ARE	ARF	ARG	ARH	ARI	ARJ	ARK	ARL	ARM	ARN	ARO	ARP
18"	ASA	ASB	ASC	ASD	ASE	ASF	ASG	ASH	ASI	ASJ	ASK	ASL	ASM	ASN	ASO	ASP
19"	ATA	ATB	ATC	ATD	ATE	ATF	ATG	ATH	ATI	ATJ	ATK	ATL	ATM	ATN	ATO	ATP
20"	AUA	AUB	AUC	AUD	AUE	AUF	AUG	AUH	AUI	AUJ	AUK	AUL	AUM	AUN	AUO	AUP
21"	AVA	AVB	AVC	AVD	AVE	AVF	AVG	AVH	AVI	AVJ	AVK	AVL	AVM	AVN	AVO	AVP
22"	AWA	AWB	AWC	AWD	AWE	AWF	AWG	AWH	AWI	AWJ	AWK	AWL	AWM	AWN	AWO	AWP
23"	AXA	AXB	AXC	AXD	AXE	AXF	AXG	AXH	AXI	AXJ	AXK	AXL	AXM	AXN	AXO	AXP

Numeric value in order code for bore in imperial dimension

Bore tolerance: clearance fit to AGMA Class1, keyway: according to ANSI-B7.1

Bore, whole number	Bore, fractional															
	0	1/16"	1/8"	3/16"	1/4"	5/16"	3/8"	7/16"	1/2"	9/16"	5/8"	11/16"	3/4"	13/16"	7/8"	15/16"
0"	ZAA	ZAB	ZAC	ZAD	ZAE	ZAF	ZAG	ZAH	ZAI	ZAJ	ZAK	ZAL	ZAM	ZAN	ZAO	ZAP
1"	ZBA	ZBB	ZBC	ZBD	ZBE	ZBF	ZBG	ZBH	ZBI	ZBJ	ZBK	ZBL	ZBM	ZBN	ZBO	ZBP
2"	ZCA	ZCB	ZCC	ZCD	ZCE	ZCF	ZCG	ZCH	ZCI	ZCJ	ZCK	ZCL	ZCM	ZAN	ZCO	ZCP
3"	ZDA	ZDB	ZDC	ZDD	ZDE	ZDF	ZDG	ZDH	ZDI	ZDJ	ZDK	ZDL	ZDM	ZND	ZDO	ZDP
4"	ZEA	ZEB	ZEC	ZED	ZEE	ZEF	ZEG	ZEH	ZEI	ZEJ	ZEK	ZEL	ZEM	ZEN	ZEO	ZEP
5"	ZFA	ZFB	ZFC	ZFD	ZFE	ZFF	ZFG	ZFH	ZFI	ZFJ	ZFK	ZFL	ZFM	ZFN	ZFO	ZFP
6"	ZGA	ZGB	ZGC	ZGD	ZGE	ZGF	ZGG	ZGH	ZGI	ZGJ	ZGK	ZGL	ZGM	ZGN	ZGO	ZGP
7"	ZHA	ZHB	ZHC	ZHD	ZHE	ZHF	ZHG	ZHH	ZHI	ZHJ	ZHK	ZHL	ZHM	ZHN	ZHO	ZHP
8"	ZIA	ZIB	ZIC	ZID	ZIE	ZIF	ZIG	ZIH	ZII	ZIJ	ZIK	ZIL	ZIM	ZIN	ZIO	ZIP
9"	ZJA	ZJB	ZJC	ZJD	ZJE	ZJF	ZJG	ZJH	ZJI	ZJJ	ZJK	ZJL	ZJM	ZJN	ZJO	ZJP
10"	ZKA	ZKB	ZKC	ZKD	ZKE	ZKF	ZKG	ZKH	ZKI	ZKJ	ZKK	ZKL	ZKM	ZKN	ZKO	ZKP
11"	ZLA	ZLB	ZLC	ZLD	ZLE	ZLF	ZLG	ZLH	ZLI	ZLJ	ZLK	ZLL	ZLM	ZLN	ZLO	ZLP
12"	ZMA	ZMB	ZMC	ZMD	ZME	ZMF	ZMG	ZMH	ZMI	ZMJ	ZMK	ZML	ZMM	ZMN	ZMO	ZMP
13"	ZNA	ZNB	ZNC	ZND	ZNE	ZNF	ZNG	ZNH	ZNI	ZNJ	ZNK	ZNL	ZNM	ZNN	ZNO	ZNP
14"	ZOA	ZOB	ZOC	ZOD	ZOE	ZOF	ZOG	ZOH	ZOI	ZOJ	ZOK	ZOL	ZOM	ZON	ZOO	ZOP
15"	ZPA	ZPB	ZPC	ZPD	ZPE	ZPF	ZPG	ZPH	ZPI	ZPJ	ZPK	ZPL	ZPM	ZPN	ZPO	ZPP
16"	ZQA	ZQB	ZQC	ZQD	ZQE	ZQF	ZQG	ZQH	ZQI	ZQJ	ZQK	ZQL	ZQM	ZQN	ZQO	ZQP
17"	ZRA	ZRB	ZRC	ZRD	ZRE	ZRF	ZRG	ZRH	ZRI	ZRJ	ZRK	ZRL	ZRM	ZRN	ZRO	ZRP
18"	ZSA	ZSB	ZSC	ZSD	ZSE	ZSF	ZSG	ZSH	ZSI	ZSJ	ZSK	ZSL	ZSM	ZSN	ZSO	ZSP
19"	ZTA	ZTB	ZTC	ZTD	ZTE	ZTF	ZTG	ZTH	ZTI	ZTJ	ZTK	ZTL	ZTM	ZTN	ZTO	ZTP
20"	ZUA	ZUB	ZUC	ZUD	ZUE	ZUF	ZUG	ZUH	ZUI	ZUJ	ZUK	ZUL	ZUM	ZUN	ZUO	ZUP
21"	ZVA	ZVB	ZVC	ZVD	ZVE	ZVF	ZVG	ZVH	ZVI	ZVJ	ZVK	ZVL	ZVM	ZVN	ZVO	ZVP
22"	ZWA	ZWB	ZWC	ZWD	ZWE	ZWF	ZWG	ZWH	ZWI	ZWJ	ZWK	ZWL	ZWM	ZWN	ZWO	ZWP
23"	ZXA	ZXB	ZXC	ZXD	ZXE	ZXF	ZXG	ZXH	ZXI	ZXJ	ZXK	ZXL	ZXM	ZXN	ZXO	ZXP

Questionnaire for selecting Tru-Line Flange-Couplings RFK ... TBO

Please photocopy or use the technical query from our website (www.ringspann.com)!

Company:	Department:
Address:	Name:
.....	Enquiry:
Phone:	Date:
Fax:	E-mail:

1. Type of application

1.1 Machine type, machine group or drive:

2. Operating data

2.1 Performance data

Driving power	P_n	_____	[kW]
Max. shaft speed	n_M	_____	$[\text{min}^{-1}]$
Nominal torque	M_N	_____	[Nm]
Max. torque	M_{max}	_____	[Nm]
Min. safety factor	S_{min}	_____	[1]
Max. bending moment	M_b	_____	[Nm]
Max. radial force	F_{rad}	_____	[N]
Max. axial force	F_{ax}	_____	[N]

2.2 Installation conditions

- outside
 in a closed room

Ambient temperatures
 from _____ °C to _____ °C

2.3 Supplement

Please send us a description and drawing in the event of other installation conditions. We are happy to review them and provide recommendations.

3. Dimensions

3.1 Data of shaft

Shaft 1/Flange 1

Shaft diameter	d_1	_____	[mm]
Shaft material		_____	
Shaft tolerance	T_{1W}	_____	[mm]
Average surface roughness	R_{z1}	_____	$[\mu\text{m}]$

Shaft 2/Flange 2

Shaft diameter	d_2	_____	[mm]
Shaft material		_____	
Shaft tolerance	T_{2W}	_____	[mm]
Average surface roughness	R_{z2}	_____	$[\mu\text{m}]$

Drawing of the coupling with dimensions of the shaft ends

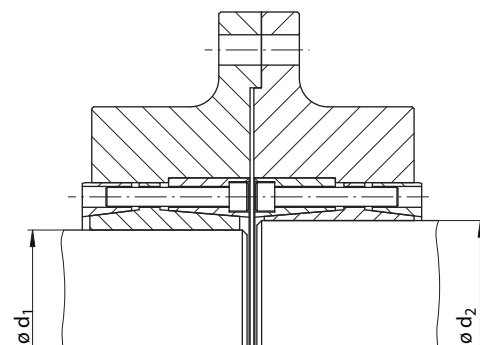

Please photocopy or use the technical query from our website (www.ringspann.com)!

Company:	Department:
Address:	Name:
.....	Enquiry:
Phone:	Date:
Fax:	E-mail:

1. Type of application

1.1 Machine type, machine group or drive:

2. Operating data

2.1 Drive type

- Electric motor
- Combustion engine
 - Fuel type: Petrol
 - Diesel
 - Natural gas
 - Other: _____
- Number of cylinders _____
- Gearbox
- Other: _____

Service factor S_B _____

Total torque of the application _____ [Nm]

2.3 Operating data

- in a closed room
 - outside, protected
 - outside, sea air
 - Aggressive
 - hazardous area, zone
- _____
- Other (accessibility, dusty atmosphere, etc.)
- _____

2.2 Performance data

Driving power _____ [kW]

Speed of the drive / of the gearbox _____ [min^{-1}]

Ambient temperatures from _____ °C to _____ °C

3. Dimensions

3.1 Motor shaft

Cylindrical shaft with keyway

Diameter of the drive shaft _____ [mm]

Keyway dimensions _____ [mm]

Usable shaft length of the drive shaft _____ [mm]

Please provide more details: clearance fit, press fit, metric coupling size (P7, H7, etc.), with or without set screw, clamping elements / clamping sets

Special drive shaft

Specification

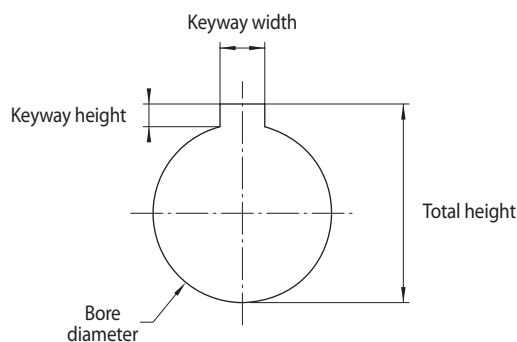

Please photocopy or use the technical query from our website (www.ringspann.com)!

Company:	Department:
Address:	Name:
.....	Enquiry:
Phone:	Date:
Fax:	E-mail:

3.2 Output shaft

Cylindrical shaft with keyway

Diameter of the output shaft _____ [mm]

Keyway dimensions _____ [mm]

Usable shaft length of the output shaft _____ [mm]

Please provide more details:
clearance fit, press fit, metric coupling size (P7, H7, etc.), with or without set screw, clamping elements / clamping sets

Thread coupling size _____

Thread length _____ [mm]

Diameter of the spacer _____ [mm]

Thickness of the disc _____ [mm]

Special output shaft

Specification

Taper shaft end

Min. diameter of the taper _____ [mm]

Max. diameter of the taper _____ [mm]

T (gradient) _____

Wrench size _____

3.3 Distances

Distance between the shaft ends _____ [mm]

Total installation length _____ [mm]

Please specify any obstacles, beams, protective grating, pipes, etc.

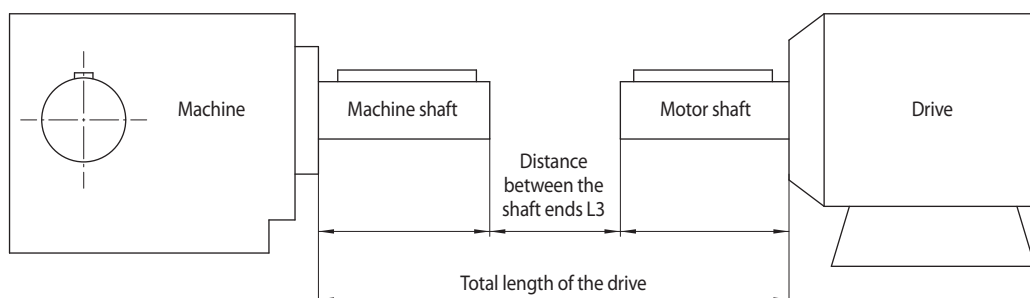

7. Estimated requirements

_____ Piece (one-off) _____ Piece/month _____ Piece/year

8. Appendices

Specifications Data sheet Sketch/drawing

Germany

RINGSPANN GmbH

Schaberweg 30 - 38, 61348 Bad Homburg, Germany
+49 61 72 2750
info@ringspann.de • www.ringspann.de

RINGSPANN RCS GmbH

Hans-Mess-Straße 7, 61440 Oberursel, Germany
+49 61 72 67 68 50
info@ringspann-rcs.de • www.ringspann-rcs.de

France

SIAM - RINGSPANN S.A.

23 rue Saint-Simon, 69009 Lyon, France
+33 4 78 83 59 01
info@siam-ringspann.fr • www.ringspann.fr

Great Britain, Ireland

RINGSPANN (U.K.) LTD.

3, Napier Road, Bedford MK41 0QS, Great Britain
+44 12 34 34 25 11
info@ringspann.co.uk • www.ringspann.co.uk

Italy

RINGSPANN Italia S.r.l.

V.le A. De Gasperi, 31, 20020 Lainate (MI), Italy
+39 02 93 57 12 97
info@ringspann.it • www.ringspann.it

Netherlands, Belgium, Luxembourg

RINGSPANN Benelux B.V.

Nieuwenkampsmaten 6 - 15, 7472 DE Goor,
Netherlands • +31 547 26 13 55
info@ringspann.nl • www.ringspann.nl

Austria, Hungary, Slovenia

RINGSPANN Austria GmbH

Kleegasse 9, 2624 Breitenau, Austria
+43 26 35 62446
info@ringspann.at • www.ringspann.at

Poland

Radius-Radpol Wiecheć Sp.J.
ul. Kolejowa 16 b, 60-185 Skórzewo, Poland
+48 61 814 39 28 • info@radius-radpol.com.pl
www.radius-radpol.com.pl

Romania, Bulgaria, Moldova

S.C. Industrial Seals and Rolls S.R.L.
Str. Depozitelor, Nr. 29, 110078 Pitesti, Romania
+4 0751 22 82 28
mihai@isar.com.ro • www.isar.com.ro

Sweden, Finland, Denmark, Norway,
Baltic states**RINGSPANN Nordic AB**

Industrigatan 7, 61933 Trosa, Sweden
+46 156 190 98
info@ringspann.se • www.ringspann.se

Switzerland

RINGSPANN AG

Sumpfstrasse 7, P.O. Box 3320, 6303 Zug,
Switzerland • +41 41 748 0900
info@ringspann.ch • www.ringspann.ch

Spain, Portugal

RINGSPANN IBERICA S.A.

C/Uzbina, 24-Nave E1, 01015 Vitoria, Spain
+34 945 22 77-50
info@ringspann.es • www.ringspann.es

Czech Republic, Slovakia

Ing. Petr Schejbal
Mezivřší 1444/27, 14700 Prag, Czech Republic
+420 222 96 90 22
Petr.Schejbal@ringspann.cz • www.ringspann.com

Ukraine

"START-UP" LLC.

Lev Landau av. 155 B, office 206, Kharkiv 61060,
Ukraine • +38 057 717 03 04
start-up@start-up.kh.ua • www.start-up.kh.ua

Asia

Australia, New Zealand

RINGSPANN Australia Pty Ltd

Unit 5, 13A Elite Way, Carrum Downs Vic 3201,
Australia • +61 3 9069 0566
info@ringspann.com.au • www.ringspann.com.au

China, Taiwan

RINGSPANN Power Transmission (Tianjin) Co., Ltd.

No. 21 Gaoyan Rd., Binhai Science and Technology
Park, Binhai Hi-Tech Industrial, Development Area,
Tianjin, 300458, P.R. China • +86 22 5980 31 60
info.cn@ringspann.cn • www.ringspann.cn

India, Bangladesh, Nepal

RINGSPANN Power Transmission India Pvt. Ltd.

GAT No: 679/2/1, Village Kuruli, Taluka Khed, Chakan-
Alandi Road, Pune - 410501, Maharashtra, India
+91 21 35 67 75 00 • info@ringspann-india.com
www.ringspann-india.com

Kazakhstan, Central Asia

Industrial Drive LLP

193, Furmanov Street, 050013 Almaty, Kazakhstan
+7 727 350 58 68
info@promprivod.kz • www.promprivod.kz

Singapore, ASEAN

RINGSPANN Singapore Pte. Ltd.

143 Cecil Street, #17-03 GB Building,
Singapore 069542 • +65 9633 6692
info@ringspann.sg • www.ringspann.sg

South Korea

J & N TECH

Gangnam Teheran-Lo 82 Ghil 15, 2nd Fl. #8,
Seoul 06178, South Korea • +82 10 54 961 368
schinning@outlook.com • www.ringspann.kr

America

Brazil

Antares Acoplamentos Ltda.
Rua Evaristo de Antoni, 1222, Caxias do Sul, RS,
CEP 95041-000, Brazil • +55 54 32 18 68 00
vendas@antaresacoplamentos.com.br
www.antaresacoplamentos.com.br

USA, Canada, Mexico, Chile, Peru

RINGSPANN Corporation

10550 Anderson Place, Franklin Park, IL 60131, U.S.A
+1 847 678 35 81
info@ringspanncorp.com • www.ringspanncorp.com

Africa and Middle East

Egypt

Shofree Trading Co.
218 Emtedad Ramsis 2, 2775 Nasr City, Cairo, Egypt
+20 2 20 81 20 57
info@shofree.com • www.ringspann.com

Israel

G.G. Yarom Rolling and Conveying Ltd.
6, Hamaktesh Str., 58810 Holon, Israel
+972 3 557 01 15
noam_a@gg.co.il • www.ringspann.com

South Africa, Sub-Saharan

RINGSPANN South Africa (Pty) Ltd.

96 Plane Road Spartan, Kempton Park,
P.O. Box 8111 Edenglen 1613, South Africa
+27 11 394 18 30
info@ringspann.co.za • www.ringspann.co.za

Iran

Persia Robot Machine Co. Ltd.
4th Floor, No 71, Mansour St, Motahari Avenue,
Tehran 15957, Iran • +98 21 88 70 91 58-62
info@persiarobot.com • www.ringspann.com

Maghreb, West Africa

SIAM - RINGSPANN S.A.

23 rue Saint-Simon, 69009 Lyon, France
+33 4 78 83 59 01
info@siam-ringspann.fr • www.ringspann.fr