



PX - Pag. D-3



PX-R - Pag. D-3



PXB - Pag. D-4



PXT - Pag. D-4



PXP - Pag. D-4



XVR - Pag. D-6

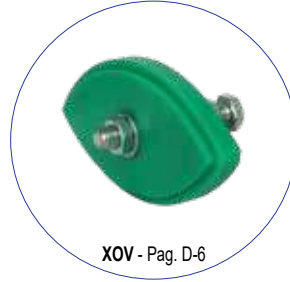

XOV - Pag. D-6



XRO - Pag. D-7

XZN / AZN
Pag. D-8

XZK - Pag. D-9



XRP - Pag. D-10



XRU - Pag. D-10

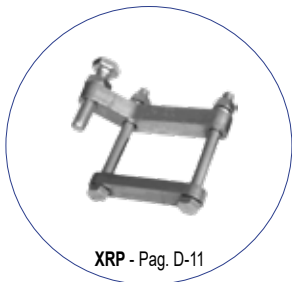

XRP - Pag. D-11



SN 5 - Pag. D-11



CIAO ELASTIC ELEMENTS IN PLASTIC AND STAINLESS STEEL



CIAO elastic elements are entirely manufactured in plastic and stainless steel; therefore, especially suitable for food - pharmaceutical industries as well as for all applications affected by corrosion problems. CIAO items are elastic elements with rotational work. The elastic deformation of four cylinders made of natural rubber, lodged inside the place that result when two elements with square section are turned at an angle of 45° one to the other, produces high elasticity and high resistance to shocks, vibrations and oscillations. Maximum rotation angle is $\pm 30^\circ$. Special design guarantees silent performances and high reliability, allows several advantageous installation solutions and solves easily application problems. These elements can be used in many fields and various applications: chain tensioners, belt tensioners, shock absorbers, vibration dampeners, downholders, decelerators, elastic supports, etc. Product size and technical data are explained near each element. Page CIAO products have the advantage to be interchangeable with CRESA products, thanks to their load capacity and size. Automatic rotation tensioners theory and assembly instructions; see chapter C (from Pag.C13 to Pag.C17).

CIAO ELEMENTI ELASTICI IN PLASTICA ED INOX



Gli elementi elastici CIAO sono costruiti interamente in materiale plastico ed acciaio INOX; quindi particolarmente utili nel settore alimentare - farmaceutico ed in tutte le applicazioni ove esistano problemi di ruggine. Gli articoli CIAO sono elementi elastici con funzionamento a rotazione. L'elevata elasticità e la grande capacità di assorbimento di urti, colpi, vibrazioni e oscillazioni è prodotta dalla deformazione elastica di quattro cilindri di gomma alloggiati nei vani risultanti dall'accoppiamento di due elementi a sezione quadrata ruotati di 45° l'uno rispetto all'altro. L'angolo di rotazione che può raggiungere è di $\pm 30^\circ$. C. La particolare costruzione garantisce un funzionamento silenzioso, di grande affidabilità, permette innumerevoli vantaggiose soluzioni di montaggio ed inoltre risolve con semplicità i vari problemi applicativi. I settori di impiego sono molteplici e moltissime le applicazioni quali: tendicatena, tendicinghia, ammortizzatori, antivibranti, pressori, deceleratori, supporti elastici, ecc. Il dimensionamento e gli specifici dati tecnici di funzionamento dei prodotti, sono descritti a lato di ogni singolo particolare. I prodotti CIAO, inoltre offrono il vantaggio di essere intercambiabili con prodotti CRESA, per capacità di carico e geometria. Per la teoria sui tenditori automatici a rotazione e per le istruzioni di montaggio si rimanda al capitolo C (da Pag.C13 a Pag.C17).

Type - Tipo: **PX**



USE Tensioner device
Elemento tenditore

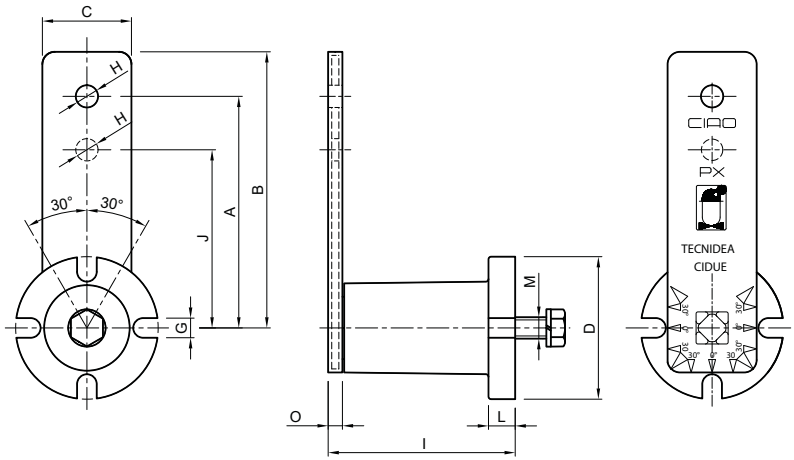

UK MATERIALS Body is made of plastic with a brass insert. Lever is made of plastic with steel rib. Stainless steel screws.
TREATMENTS The rib is galvanized.
USE Temperature from -35°C to +80°C.

IT MATERIALI Corpo in plastica con inserto in ottone. Leva in plastica con nervatura in acciaio. Viti in acciaio inossidabile.
TRATTAMENTI La nervatura della leva è zincata.
IMPIEGO Temperatura da -35°C a +80°C.



Type Tipo	Cod. N°	A	B	C	ØD	G	ØH	I	J	L	M	O	R	Newton 0°-30°		Weight Peso (kg)	Type Tipo	Cod. N°	
														Arm Braccio (A)	Arm Braccio (J)				
PX 10	RE010910	80	90	24	40	7	8,5	52	+1,5 -0,5	60	6	M6x20	7	7,5	0+90	0+120	0,10	PX 10 R	RE010911
PX 20	RE010920	100	112	30	50	9	10,5	66	+1,5 -0,5	80	8	M8x25	8	9,2	0+140	0+175	0,20	PX 20 R	RE010921
PX 30	RE010930	100	115	36	60	9	10,5	79	+1,5 -0,5	80	10	M10x30	8	10,5	0+340	0+475	0,26	PX 30 R	RE010931
PX 40	RE010940	130	155	50	80	11	12,5	108	+2,0 -1,0	100	15	M12x40	10	10,5	0+ 860	0+1118	0,72	PX 40 R	RE010941

D

Type - Tipo: **PXR**



USE Reinforced tensioner device
Elemento tenditore rinforzato

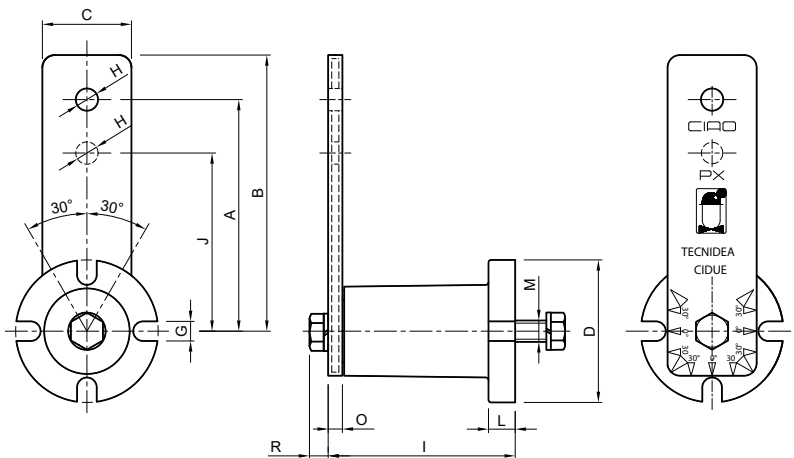

UK MATERIALS Body is made of plastic with a brass insert. Lever is made of plastic with steel rib. Stainless steel screws.
TREATMENTS The rib is galvanized.
USE Temperature from -35°C to +80°C.

IT MATERIALI Corpo in plastica con inserto in ottone. Leva in plastica con nervatura in acciaio. Viti in acciaio inossidabile.
TRATTAMENTI La nervatura della leva è zincata.
IMPIEGO Temperatura da -35°C a +80°C.



Type - Tipo: PXB



USE Bayonet base
Base a baionetta

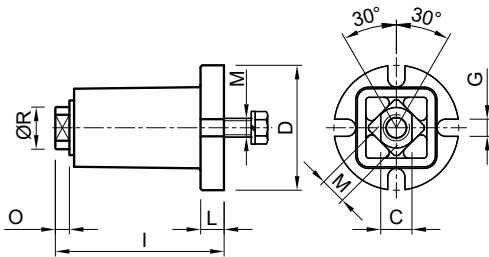

UK MATERIALS Body is made of plastic with a brass insert. Pin and screws is made of stainless steel.
USE Temperature from -35°C to +80°C.

IT MATERIALI Corpo in plastica con inserto in ottone. Perno e viti in acciaio inossidabile.
IMPIEGO Temperatura da -35°C a +80°C.

Type Tipo	Cod. N°	C	ØD	G	I	L	M	O	R	Torque Q Carico Q (Nm) 0°-30°	Weight Peso (kg)
PXB 10	RE010990	9,5	40	7	50 ^{+1,5} _{-0,5}	6	M6	5	11	0 ±7,2	0,10
PXB 20	RE010991	12,0	50	9	62 ^{+1,5} _{-0,5}	8	M8	5	15	0 ±14,0	0,16
PXB 30	RE010992	14,5	60	9	77 ^{+1,5} _{-0,5}	10	M10	7	18	0 ±38,0	0,20
PXB 40	RE010993	20,0	80	11	106 ^{+2,0} _{-1,0}	15	M12	9	27	0 ±111,8	0,63

Q: Torque (Nm) / Carico di Torsione (Nm)

Type - Tipo: PXT



USE Tube base
Base a tubo

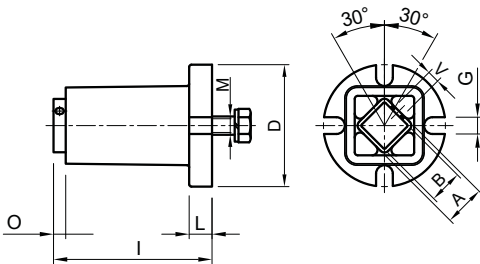

UK MATERIALS Body is made of plastic with a brass insert. Pin and screws is made of stainless steel.
USE Temperature from -35°C to +80°C.

IT MATERIALI Corpo in plastica con inserto in ottone. Perno e viti in acciaio inossidabile.
IMPIEGO Temperatura da -35°C a +80°C.

Type Tipo	Cod. N°	A	B	ØD	G	I	L	M	O	V	Torque Q Carico Q (Nm) 0°-30°	Weight Peso (kg)
PXT 10	RE011000	12	9	40	7	50 ^{+1,5} _{-0,5}	6	M6	6	M4	0 ±7,2	0,10
PXT 20	RE011001	15	12	50	9	64 ^{+1,5} _{-0,5}	8	M8	8	M4	0 ±14,0	0,12
PXT 30	RE011002	20	16	60	9	77 ^{+1,5} _{-0,5}	10	M10	8	M5	0 ±38,0	0,15
PXT 40	RE011003	27	22	80	11	106 ^{+2,0} _{-1,0}	15	M12	10	M6	0 ±111,8	0,53

Q: Torque (Nm) / Carico di Torsione (Nm)

Type - Tipo: PXP



USE Flat base
Base piana

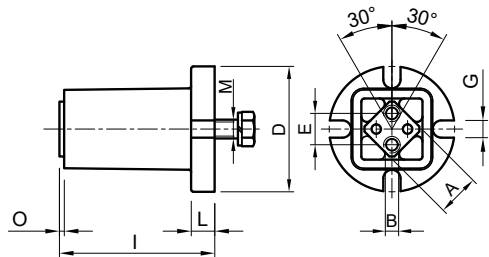

UK MATERIALS Body is made of plastic with a brass insert. Pin is made of aluminium. Stainless steel screws.
USE Temperature from -35°C to +80°C.

IT MATERIALI Corpo in plastica con inserto in ottone. Perno in alluminio. Viti in acciaio inossidabile.
IMPIEGO Temperatura da -35°C a +80°C.

Type Tipo	Cod. N°	A	B	ØD	E	G	I	L	M	O	Torque Q Carico Q (Nm) 0°-30°	Weight Peso (kg)
PXP 20	RE011005	15	M6x15	50	10	9	57 ^{+1,5} _{-0,5}	8	M8	1	0 ± 14,0	0,12
PXP 30	RE011006	18	M6x15	60	12	9	70 ^{+1,5} _{-0,5}	10	M10	1	0 ± 38,0	0,15
PXP 40	RE011007	27	M10x30	80	20	11	97 ^{+2,0} _{-1,0}	15	M12	1	0 ± 111,8	0,53

Q: Torque (Nm) / Carico di Torsione (Nm)

ISO	Pitch Passo	CHAIN - CATENA DIN 8187						Size Taglia	BELT - CINGHIA		
		Type - Tipo							Type - Tipo		Max belt width Largh. massima cinghia
		XVR Pag. D-6	XOV Pag. D-6	XRO Pag. D-7	XZN Pag. D-8	AZN Pag. D-8	XZK Pag. D-9		XRP Pag. D-10	XRU Pag. D-10	
05-B1	8 mm	XVR 10-0S	-	XRO 10-0S	-	-	-	10	XRP 1	XRU 1	30
06-B1	3/8" x 7/32"	XVR 10-1S	XOV 10-1S	XRO 10-1S	-	-	-	10	-	-	-
06-B1	3/8" x 7/32"	-	-	-	XZN 20-1S	AZN 20-1S	XZK 20-1S	20	-	-	-
06-B1	3/8" x 7/32"	-	-	-	XZN 30-1S	AZN 30-1S	XZK 30-1S	30	-	-	-
08-B1	1/2" x 5/16"	XVR 20-2S	XOV 20-2S	XRO 20-2S	-	-	-	20	XRP 2/3	XRU 2/3	40
08-B1	1/2" x 5/16"	XVR 30-2S	XOV 30-2S	XRO 30-2S	XZN 30-2S	AZN 30-2S	XZK 30-2S	30	XRP 2/3	XRU 2/3	40
10-B1	5/8" x 3/8"	XVR 30-3S	XOV 30-3S	XRO 30-3S	XZN 30-3S	AZN 30-3S	-	30	-	-	-
10-B1	5/8" x 3/8"	-	-	-	XZN 40-3S	AZN 40-3S	XZK 40-3S	40	XPR 4	XRU 4	55
12-B1	3/4" x 7/16"	XVR 30-4S	XOV 30-4S	XRO 30-4S	-	-	-	30	-	-	-
12-B1	3/4" x 7/16"	XVR 40-4S	XOV 40-4S	XRO 40-4S	-	-	XZK 40-4S	40	-	-	-
16-B1	1" x 17,02mm	XVR 40-5S	-	XRO 40-5S	-	-	XZK 40-5S	40	-	-	-
05-B2	8 mm	XVR 10-0D	-	XRO 10-0D	-	-	-	10	-	-	-
06-B2	3/8" x 7/32"	XVR 10-1D	XOV 10-1D	XRO 10-1D	-	-	-	10	-	-	-
06-B2	3/8" x 7/32"	-	-	-	-	-	XZK 20-1D	20	-	-	-
06-B2	3/8" x 7/32"	-	-	-	-	-	XZK 30-1D	30	-	-	-
08-B2	1/2" x 5/16"	XVR 20-2D	XOV 20-2D	XRO 20-2D	-	-	-	20	-	-	-
08-B2	1/2" x 5/16"	XVR 30-2D	XOV 30-2D	XRO 30-2D	-	-	XZK 30-2D	30	-	-	-
10-B2	5/8" x 3/8"	XVR 30-3D	XOV 30-3D	XRO 30-3D	-	-	-	30	-	-	-
10-B2	5/8" x 3/8"	-	-	-	-	-	XZK 40-3D	40	-	-	-
12-B2	3/4" x 7/16"	XVR 30-4D	XOV 30-4D	XRO 30-4D	-	-	-	30	-	-	-
12-B2	3/4" x 7/16"	XVR 40-4D	XOV 40-4D	XRO 40-4D	-	-	XZK 40-4D	40	-	-	-
16-B2	1" x 17,02mm	XVR 40-5D	-	XRO 40-5D	-	-	XZK 40-5D	40	-	-	-
06-B3	3/8" x 7/32"	XVR 20-1T	-	XRO 20-1T	-	-	-	20	-	-	-
06-B3	3/8" x 7/32"	-	-	-	-	-	XZK 30-1T	30	-	-	-
08-B3	1/2" x 5/16"	XVR 30-2T	-	XRO 30-2T	-	-	-	30	-	-	-
08-B3	1/2" x 5/16"	-	-	-	-	-	XZK 40-2T	40	-	-	-
10-B3	5/8" x 3/8"	XVR 40-3T	-	XRO 40-3T	-	-	XZK 40-3T	40	-	-	-
12-B3	3/4" x 7/16"	XVR 40-4T	-	XRO 40-4T	-	-	XZK 40-4T	40	-	-	-
16-B3	1" x 17,02mm	XVR 40-5T	-	XRO 40-5T	-	-	-	40	-	-	-

Red codes on request.

Codici in rosso a richiesta.

HOW TO USE THE HOLE J IN PX AND PX-R COME UTILIZZARE IL FORO J NEI PX E PX-R

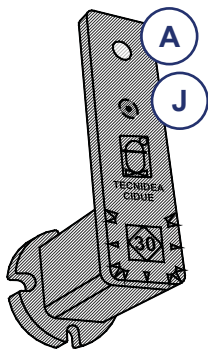

Fig.1

The tensioner is provided with the "A" hole only. The "J" hole is indicated with a reference mark.

Il tenditore si presenta con il solo foro A. Il foro J è indicato con un centrino.

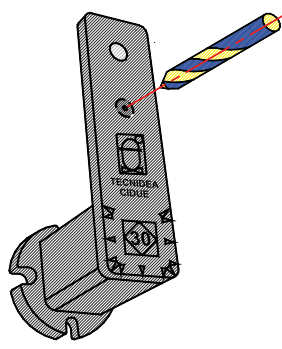

Fig.2

With a drilling operation on the reference mark You can make the J hole.

Con una foratura in corrispondenza del centrino si realizza il foro J.

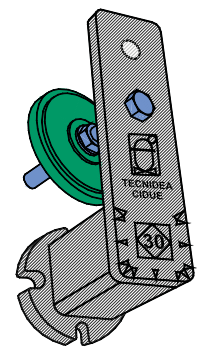

Fig.3

The KIT assembly on the hole J is the same of the hole A.

Il montaggio del KIT sul foro J è il medesimo che per il foro A.

Type - *Tipo*: XVR



USE Semi-circular sliding block
Pattino semicircolare

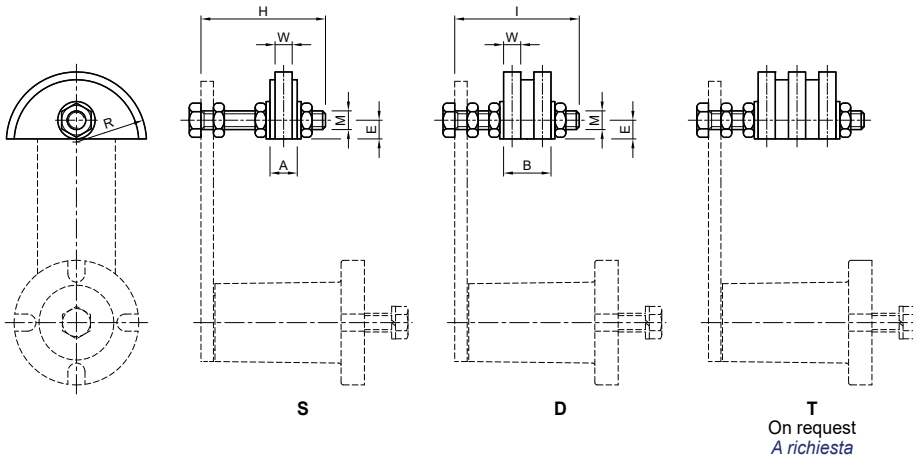

UK MATERIALS Polyethylene. Bolts are made of stainless steel.
USE Suitable for reduced distance.
Speed ≤ 20 m/min. Temperature $\leq 70^\circ\text{C}$.

IT MATERIALI Polietilene. Viti in acciaio inossidabile.
IMPIEGO Adatto per piccoli interassi.
Velocità ≤ 20 m/min. Temperatura $\leq 70^\circ\text{C}$.



Size
Taglia

Type <i>Tipo</i>	S Cod.N°	D Cod.N°	Chain <i>Catena</i>	Type <i>Tipo</i>	S Cod.N°	D Cod.N°		A	B	E	G	H	I	M	P	Q	R	W	Weight Peso (kg)		
																			S	D	
XVR 10-0	RE011975	RE011995	05-B 8 mm	-	-	-		10	10,0	12,0	10	-	45	45	M8	-	-	35	2,5	0,09	0,10
XVR 10-1	RE011976	RE011996	06-B 3/8"	XOV 10-1	RE013001	RE013021		10	10,0	18,0	10	10,2	45	45	M8	75	40	35	5,0	0,09	0,10
XVR 20-2	RE011979	RE011999	08-B 1/2"	XOV 20-2	RE013004	RE013024		20	14,0	20,5	10	13,9	55	55	M10	96	50	35	7,0	0,10	0,11
XVR 30-2	RE011979	RE012000	08-B 1/2"	XOV 30-2	RE013004	RE013025		30	14,0	20,5	10	13,9	55	60	M10	96	50	35	7,0	0,11	0,12
XVR 30-3	RE011981	RE012001	10-B 5/8"	XOV 30-3	RE013006	RE013026		30	16,5	25,0	12	16,6	55	70	M10	126	65	45	9,0	0,12	0,14
XVR 30-4	RE011983	RE012003	12-B 3/4"	XOV 30-4	RE013008	RE013028		30	17,5	30,0	12	19,5	60	70	M10	148	74	45	11,0	0,16	0,15
XVR 40-4	RE011984	RE012004	12-B 3/4"	XOV 40-4	RE013009	RE013029		40	17,5	30,0	12	19,5	80	80	M12	148	74	45	11,0	0,20	0,22
XVR 40-5	RE011986	RE012006	16-B 1"	-	-	-		40	18,0	47,0	20	-	80	90	M12	-	-	55	16,0	0,22	0,31



Type - *Tipo*: XOY



USE Oval sliding block
Pattino ovale

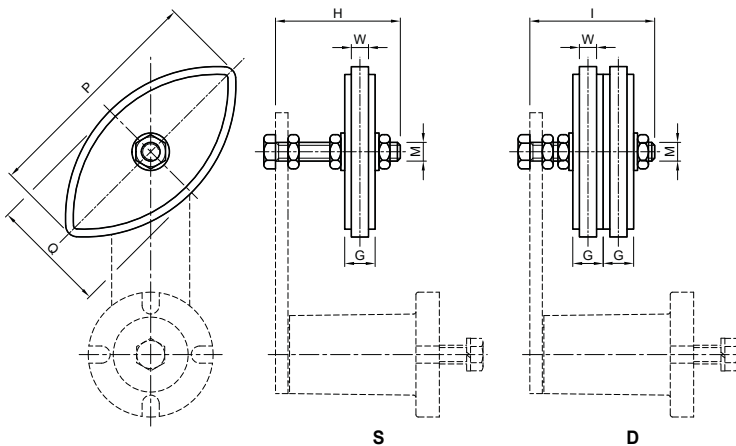

UK MATERIALS Polyethylene. Bolts are made of stainless steel.
USE Suitable for middle-size and large distance between centres.
Speed ≤ 20 m/min. Temperature $\leq 70^\circ\text{C}$.

IT MATERIALI Polietilene. Viti in acciaio inossidabile.
IMPIEGO Adatto per medi e grandi interassi.
Velocità ≤ 20 m/min. Temperatura $\leq 70^\circ\text{C}$.

Type - Tipo: XRO



USE Idler wheel
Rotella



UK MATERIALS Polyethylene. Bolts and nuts are made of stainless steel.
USE Idler wheel on the bush.
Speed ≤ 30 m/min. Temperature $\leq 70^{\circ}\text{C}$.

IT MATERIALI Polietilene. Bulloneria in acciaio inossidabile.
IMPIEGO Rotella folle sulla bussola.
Velocità ≤ 30 m/min. Temperatura $\leq 70^{\circ}\text{C}$.

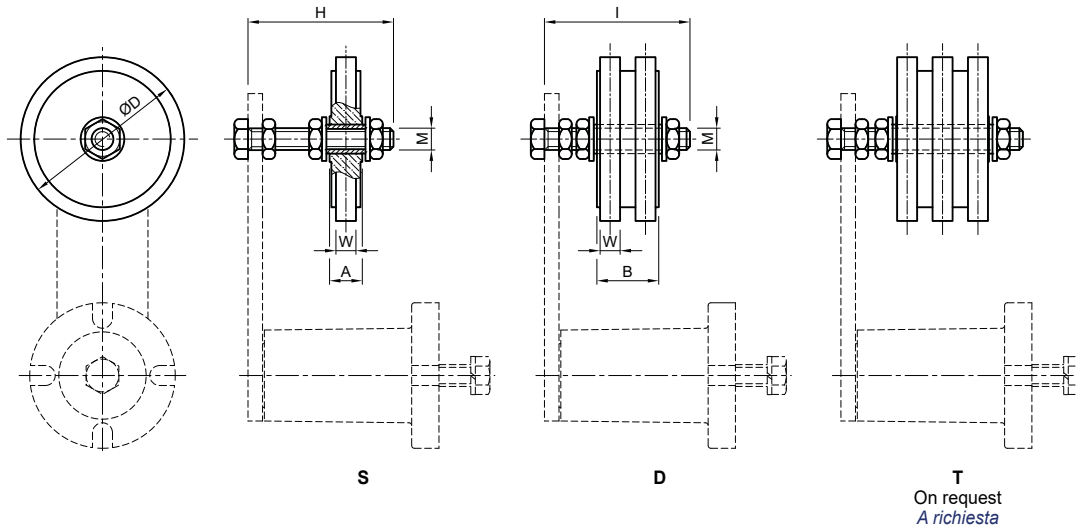

Size
Taglia

Type Tipo	S Cod. N°	D Cod. N°	Chain Catena		A	B	C	ØD	H	I	M	W	Weight Peso (kg)	
													S	D
XRO 10-0	RE012095	RE012115	05-B 8 mm		10	18	-	70	45	45	M8	2,5	0,14	0,15
XRO 10-1	RE012096	RE012116	06-B 3/8"		10	18	-	70	45	50	M8	5,0	0,14	0,15
XRO 20-2	RE012099	RE012119	08-B 1/2"		20	18	36	70	55	60	M10	7,0	0,15	0,20
XRO 30-2	RE012099	RE012120	08-B 1/2"		30	18	36	70	55	60	M10	7,0	0,16	0,22
XRO 30-3	RE012101	RE012121	10-B 5/8"		30	18	36	90	55	70	M10	9,0	0,19	0,28
XRO 30-4	RE012103	RE012123	12-B 3/4"		30	18	36	90	55	70	M10	11,0	0,19	0,29
XRO 40-4	RE012104	RE012124	12-B 3/4"		40	18	36	90	80	80	M12	11,0	0,25	0,35
XRO 40-5	RE012106	RE012126	16-B 1"		40	18	49	110	80	90	M12	16,0	0,32	0,56

APPLICATION EXAMPLES / ESEMPI DI APPLICAZIONE



Type - *Tipo*: XZN and AZN



USE Plastic idler sprocket
Pignone in plastica



UK MATERIALS The crown is made of plastic on a steel enlarged bearing.
TREATMENTS XZN bolts made of stainless steel; AZN bolts made of galvanized steel.
USE Speed ≤ 60 m/min. Temperature $\leq 100^\circ\text{C}$.

IT MATERIALI *Plastica stampata su cuscinetto a base maggiorata in acciaio.*
TRATTAMENTI XZN bulloneria in acciaio inossidabile; AZN bulloneria in acciaio zincato.
IMPIEGO Velocità ≤ 60 m/min. Temperatura $\leq 100^\circ\text{C}$.

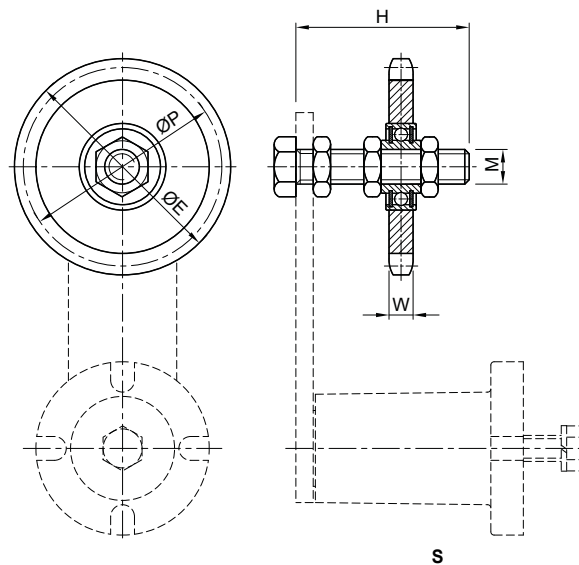

Inox steel bolts <i>Bulloneria acciaio Inox</i>		Zinc-plated steel bolts <i>Bulloneria acciaio Zincato</i>		Size <i>Taglia</i>								
Type <i>Tipo</i>	S Cod. N°	Chain <i>Catena</i>	Type <i>Tipo</i>	S Cod. N°		ØE	H	M	ØP	W	Z	Weight <i>Peso (kg)</i>
XZN 20-1S	RE012155	06-B1 3/8"	AZN 20-1S	RE012440	20	68,0	55	M10	63,90	5,3	21	0,28
XZN 30-1S	RE012155	06-B1 3/8"	AZN 30-1S	RE012440	30	68,0	55	M10	63,90	5,3	21	0,28
XZN 30-2S	RE012158	08-B1 1/2"	AZN 30-2S	RE012443	30	77,8	55	M10	73,14	7,2	18	0,30
XZN 30-3S	RE012159	10-B1 5/8"	AZN 30-3S	RE012444	30	93,0	60	M10	86,39	9,1	17	0,33
XZN 40-3S	RE012160	10-B1 5/8"	AZN 40-3S	RE012445	40	93,0	80	M12	86,39	9,1	17	0,35

APPLICATION EXAMPLES / ESEMPI DI APPLICAZIONE





Type - Tipo: **XZK**



USE INOX idler sprocket
Pignone INOX



 **MATERIALS** Stainless steel.
USE Speed ≤ 60 m/min. Temperature ≤ 100°C.

 **MATERIALI** Acciaio inossidabile.
IMPIEGO Velocità ≤ 60 m/min. Temperatura ≤ 100°C.

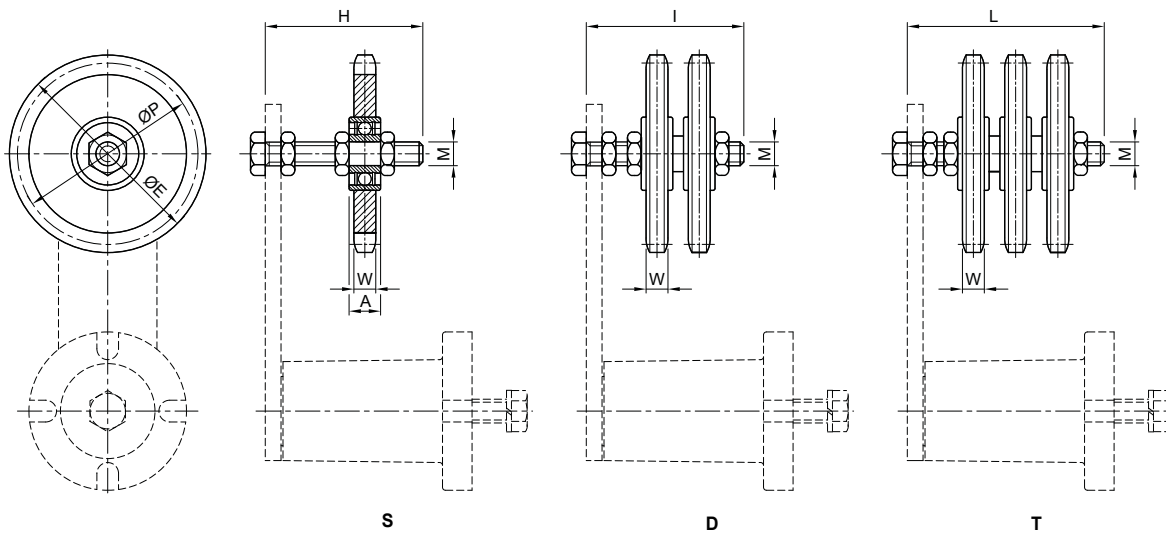

Size
Taglia

Type Tipo	S Cod. N°	D Cod. N°	T Cod. N°	Chain Catena		A	ØE	H	I	L	M	ØP	W	Z	Weight Peso (kg)		
															S	D	T
XZK 20-1	RE012310	RE012340	-	06-B 3/8"	20	9	49,3	55	55	-	M10	45,81	5,3	15	0,13	0,23	-
XZK 30-1	RE012310	RE012341	RE012370	06-B 3/8"	30	9	49,3	55	60	70	M10	45,81	5,3	15	0,13	0,23	0,26
XZK 30-2	RE012314	RE012344	-	08-B 1/2"	30	9	65,5	55	60	-	M10	61,09	7,2	15	0,21	0,37	-
XZK 40-2	-	-	RE012374	08-B 1/2"	40	12	65,5	-	-	80	M12	61,09	7,2	15	-	-	0,51
XZK 40-3	RE012318	RE012348	RE012377	10-B 5/8"	40	12	83,0	80	80	80	M12	76,36	9,1	15	0,38	0,60	0,96
XZK 40-4	RE012321	RE012351	RE012381	12-B 3/4"	40	12	99,8	80	80	90	M12	91,63	11,1	15	0,56	1,00	1,50
XZK 40-5	RE012325	RE012355	-	16-B 1"	40	12	117,0	100	120	-	M12	106,12	16,2	13	1,00	1,90	-

APPLICATION EXAMPLES / ESEMPI DI APPLICAZIONE



Type - Tipo: **XRP**



USE Shielded plastic roller
Rullo in plastica schermato

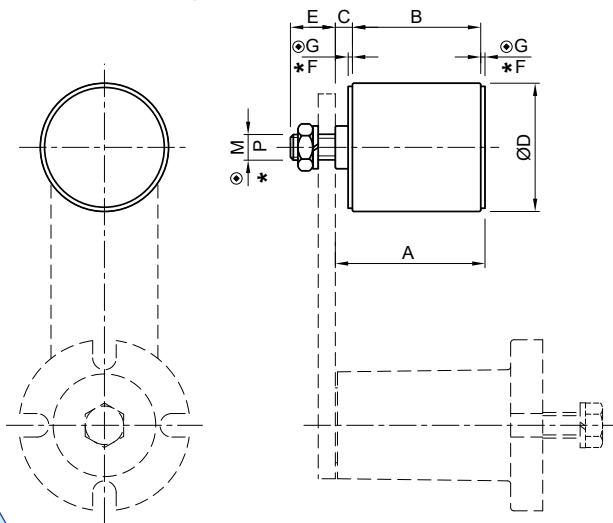

MATERIALS Roller and stoppers are made of black polyamide, steel bearings, spacers and screws are made of stainless steel.
USE Temperature $\leq 70^{\circ}\text{C}$.

MATERIALI Rullo e tappi in poliammide nero, cuscinetti in acciaio, distanziali e viti in acciaio inox.
IMPIEGO Temperatura $\leq 70^{\circ}\text{C}$.

⊙ For polyamide-roller : Screw "M"
Per rullo in poliammide : Vite "M"



Type Tipo	Cod. N°	Weight Peso (kg)	A	B	C	ØD	E	* F	⊙ G	⊙ M	* P	Size Taglia	Type Tipo	Cod. N°	Weight Peso (kg)
XRP 1	RE011960	0,08	38	35	3	30	18	2	2	M8	M8	10	XRU 1	RE010970	0,16
XRP 2/3	RE011962	0,18	51	45	6	40	21	2	2	M10	M10	20-30	XRU 2/3	RE010972	0,37
XRP 4	RE011964	0,40	68	60	8	60	21	4	2	M12	M16	40	XRU 4	RE010974	0,85

Type - Tipo: **XRU**



USE Shielded INOX roller
Rullo INOX schermato

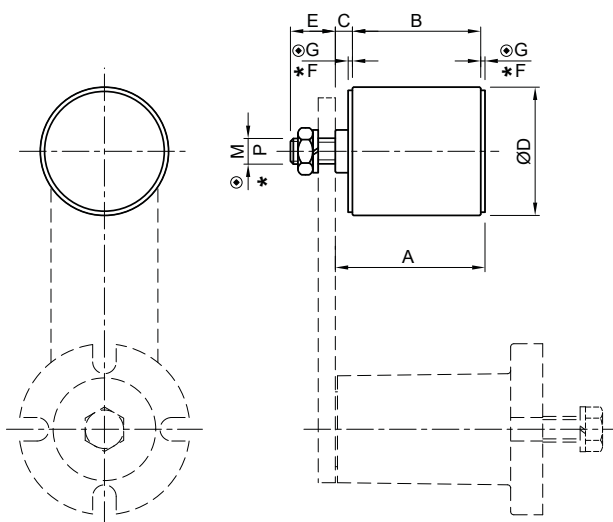

MATERIALS Roller, spacers and screws are made of stainless steel, steel bearings, stoppers are made of black polyamide.
USE Temperature $\leq 70^{\circ}\text{C}$.

MATERIALI Rullo, distanziali e viti in acciaio inox, cuscinetti in acciaio, tappi in poliammide nero.
IMPIEGO Temperatura $\leq 70^{\circ}\text{C}$.

* For stainless steel-roller : Screw "P"
Per rullo in acciaio inox : Vite "P"



WORK FIELD / CAMPO DI LAVORO

Type Tipo	Ø Roller Rullo	Max rpm Numero di giri max	Bearing Cuscinetto
XRU1	30	8000	608
XRU 2/3	40	8000	6200
XRU 4	60	6000	6301

Type Tipo	Ø Roller Rullo	Max rpm Numero di giri max	Bearing Cuscinetto
XRU 1	30	8000	608
XRU 2/3	40	8000	6200
XRU 4	60	6000	6304

NOTE: The rpm indicated in the table is approximate. The application must be considered according to the use, the service factor and working conditions.
Il numero di giri descritto in tabella è indicativo. L'applicazione va valutata in base al tipo d'impiego, il fattore di servizio e le condizioni di lavoro.

Type - *Tipo*: XPR



USE INOX preloading
Pre carica INOX

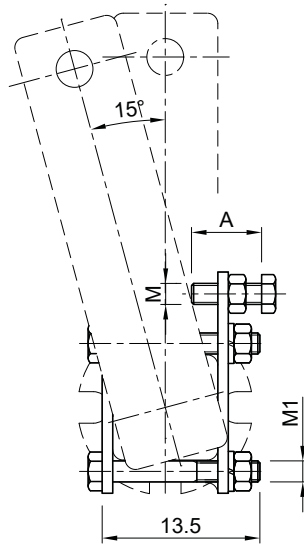
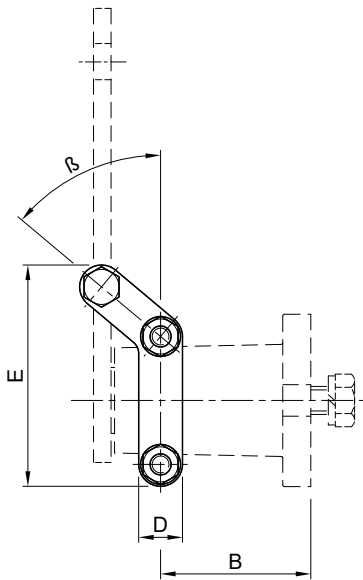

UK MATERIALS Stainless steel.
USE It allows to preload easily the elastic element, to predetermine the initial load and the work range. This product is suitable for the realization of pressure sets, calibrators and precision shock absorbers.

IT MATERIALI Acciaio inossidabile.
IMPIEGO Consente di precaricare facilmente l'elemento elastico, predeterminare il carico iniziale ed il campo di lavoro. Questo prodotto è ideale per la realizzazione di gruppi di pressione, calibratori ed ammortizzatori di precisione.

Type <i>Tipo</i>	Cod.N°	β	A	B	C	D	E	M	M1	Weight <i>Peso</i> (kg)
XPR 10	RE012450	47,5°	20	34,5	40	12,5	55,8	M6	M6	0,065
XPR 20	RE012452	50,0°	20	44,0	45	12,5	63,1	M6	M6	0,070
XPR 30	RE012454	45,0°	25	54,2	55	17,0	81,3	M8	M8	0,160
XPR 40	RE012456	44,5°	30	75,7	80	16,0	96,5	M10	M8	0,390

D

Type - *Tipo*: SN5 - Cod. RE010880

USE Mini tensioner device
Minitenditore

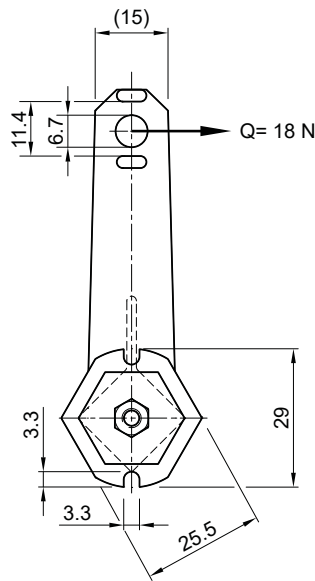
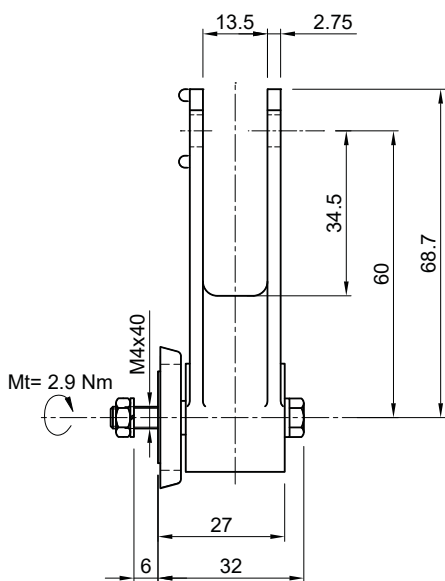

UK MATERIALS It is made of plastic material. Bolts and nuts are made of steel.
TREATMENTS Bolts and nuts are made of galvanized steel.
USE Mini tensioners or small pressure units.

IT MATERIALI Realizzato in materiale plastico. Bulloneria e riscontro in acciaio.
TRATTAMENTI Bulloneria e riscontro in acciaio zincato.
IMPIEGO Piccoli tensionamenti o gruppi di pressione.

Mt: Fixing torque screw / Coppia di serraggio vite

INSTALLATION GUIDELINES FOR BELT DRIVERS LINEE GUIDA PER L'INSTALLAZIONE DEI TENDICINGHIA

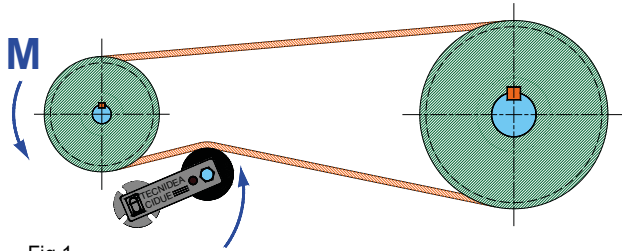

Fig.1

The belt tensioners RP and RU must be assembled near the driving pulley. They can be positioned also inside the transmission.

I rulli tendicinghia RP e RU devono essere montati vicino alla puleggia motrice. Possono essere posizionati anche all'interno della trasmissione.

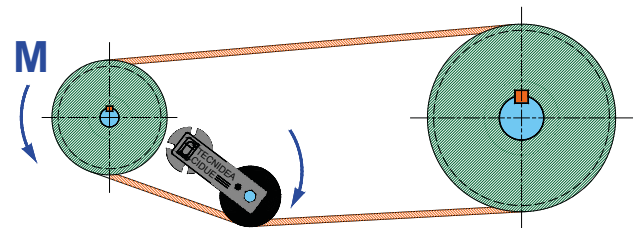

Fig.2

Tensioners assembled with pulleys for V-type belt must be assembly inside the transmission system.

I tenditori che montano pulegge per cinghie trapezoidali devono essere montati all'interno del sistema di trasmissione.

BELT TENSIONING / TENSIONE DELLE CINGHIE

V-Belt Cinghia	L [mm]	H [mm]	D _p [mm]	Q ₁ [N]	Q ₀ [N]	Type / Tipo RE-FE or PX/PX-R (generic selection / selezione generica)				
						1 belt	2 belts	3 belts	4 belts	5 belts
XPZ SPZ	10	8	56 - 71	20	16	10	30	30	30	30
			75 - 90	22	18	10	30	30	30	40
			95 - 125	25	20	20	30	30	30	40
			≥ 125	28	22	20	30	30	40	40
XPA SPA	13	10	80 - 100	28	22	20	30	30	40	40
			106 - 140	38	30	20	30	40	40	40
			150 - 200	45	36	30	30	40	40	40
			≥ 200	50	40	30	30	40	40	50
XPB SPB	16	13	112 - 160	50	40	30	30	40	40	50
			170 - 224	62	50	30	40	40	50	50
			236 - 355	77	62	30	40	50	50	50
			≥ 355	81	65	30	40	50	50	50
XPC SPC	22	18	224 - 250	87	70	30	40	50	50	50
			265 - 355	115	92	40	50	50	60	60
			≥ 375	144	115	40	50	50	60	60
Z	10	6	56 - 100	5 - 7,5		10	10	10	20	20
A	13	8	80 - 140	10 - 15		10	20	30	30	30
B	17	10	125 - 200	20 - 32		20	30	30	40	40
C	22	12	200 - 400	40 - 60		30	40	40	50	50
D	32	19	355 - 600	70 - 105		30	40	50	50	60

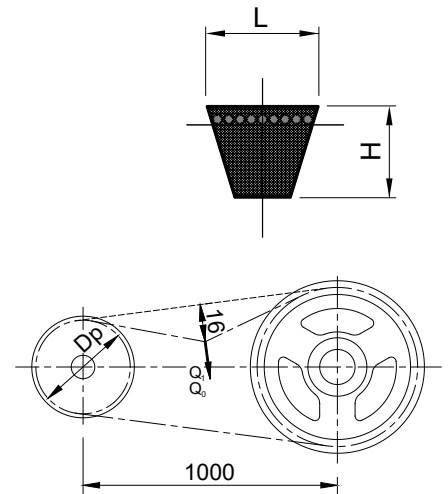

Q₁: Initial operation test force given by guidelines of belt manufacturer
 Forza iniziale di prova data dai costruttori di cinghie
 Q₀: Operational test-force / Forza di prova a regime

In order to obtain the ideal tension must be applied Q₁ force in the middle of each section of the belt, verifying that the belt deflection is 16 mm with transmission interaxle distance of 1000 mm. The relevant deflection by shorter or longer centre distance has to be interpolated accordingly. After the first running in period, the belts lose resistance, therefore the operational test-force Q₀ decreased around 20% compared Q₁.

Per ottenere la tensione ideale bisogna applicare la forza Q₁ al centro del tratto di ogni cinghia, verificando che la freccia sia di 16 mm per un interasse di trasmissione di 1000 mm. Per trasmissioni con interasse maggiore o minore il valore della freccia va interpolato. Dopo un primo rodaggio le cinghie perdono resistenza, per cui la forza di prova a regime Q₀ decresce di circa 20% rispetto Q₁.

BELT TENSIONING MEASURING INSTRUMENTS / STRUMENTI DI MISURA DELLA TENSIONE DELLE CINGHIE

