

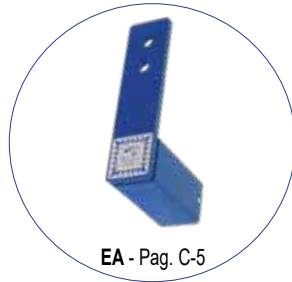

EAR - Pag. C-5



EA - Pag. C-5



EFR - Pag. C-6

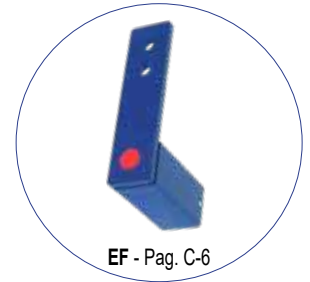

EF - Pag. C-6



EBR - Pag. C-7

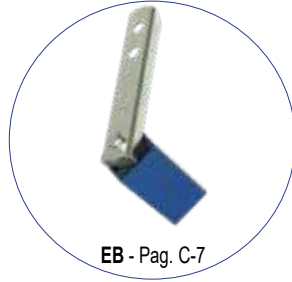

EB - Pag. C-7

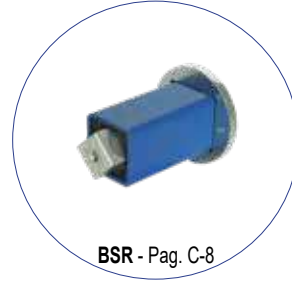

BSR - Pag. C-8

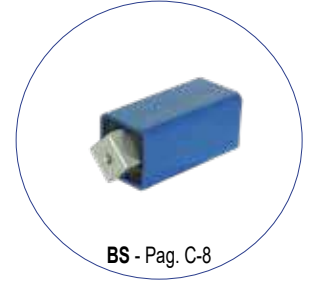

BS - Pag. C-8



BL - Pag. C-9

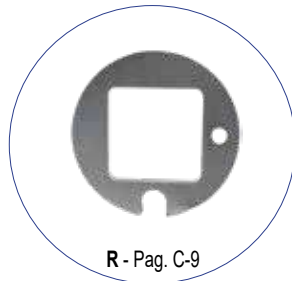

R - Pag. C-9

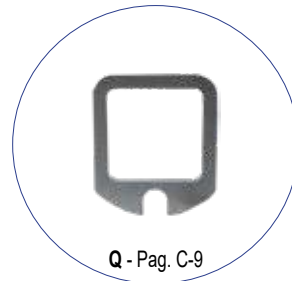

Q - Pag. C-9



S - Pag. C-9

🇬🇧 ECO: SIMPLE AND CHEAP ELASTIC ELEMENTS

The ECO elastic components are simple in their applications and economically advantageous. The strong constructive solution is made mainly with tubular steel profiles: this allowed us to create a robust and competitive product in every market without renouncing the quality and mechanical characteristics of the traditional CRESA tensioners. These characteristics are improvements and allow numerous constructive and application solutions concerning the known technologies.

ECO items such as CRESA and CIAO are elastic elements with rotational functioning. ECO tensioners exploit the elastic deformation of four natural rubber cylinders housed in the compartments resulting from two square-section components coupling rotated by 45° around each other. The rotation angle it can reach is $\pm 30^\circ$. This operating principle is thus simple, reliable, and silent.

Compared to the CRESA and CIAO elastic elements, ECO, although having identical assembly solutions, boasts innovative aspects thanks to the use of contrast rings (R, Q, S). ECO finds space in many sectors of use and especially in applications where there is the need to stretch (chain tensioner and belt tensioner), push (scraper), or press (down holders).

The ECO range develops starting from the base elastic elements EA (rear mounting) and EF (front mounting), which can be associated with anti-rotation accessories (R, Q, S). The R accessory is the most common, this is why the EAR and EFR elements have been included in the catalog, already containing both the elastic element and the contrast ring.

Page C-8 shows the elastic elements BS and BSR from which the elastic elements EB and EBR are created with the assembly of a lever made of bent sheet metal.

ECO products are perfectly interchangeable concerning load and geometry, assembly screws, and dimensions with CRESA articles.

Furthermore, the ECO elastic elements, if used as chain and belt tensioners, can mount all the interface kits for chains and belts of the CRESA series, therefore: VR and OVR polyethylene sliding block (Pag.C-32), RO polyethylene wheel (Pag.C-33), idler sprocket ZN, ZI (Pag.C-34) and ZK (Pag.C-35), RP polyamide roller (Pag.C-37), RU steel roller (Pag.C-38) and grooved pulley SP (Pag.C-39).

Mounting systems and application examples are illustrated on pages C-39 to C-41.

INNOVATION OF ECO:

The most relevant innovation of ECO compared to known techniques is its conformation adjustable according to operational requirements. Starting from the base product type EA, EF or EB, these can be implemented according to the construction need. Both EA, EF and EB are comprehensively functional, and the square shape of the fixing base guarantees stable anchoring to the wall under the pressure exerted by the fixing screw. If large radial forces on the lever are present, the tensioners can be combined with three different contrast (reaction) rings to ensure rotational stability. These elements have different shapes depending on the application's need. See application examples. All R, Q, and S rings can be mounted indifferently on the body of the tensioner on each side of the same Pag. C-3 (Fig.1-12).

 **CONTRAST RINGS - CONFIGURATION**

 **ANELLI DI CONTRASTO - CONFIGURAZIONE**

Type - *Tipo*: **EAR**

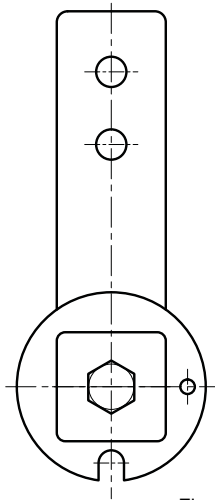

Fig.1

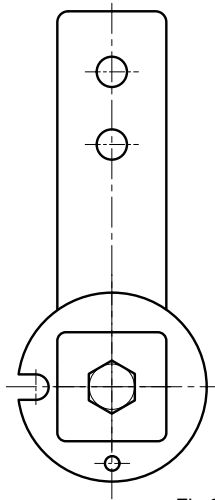

Fig.2

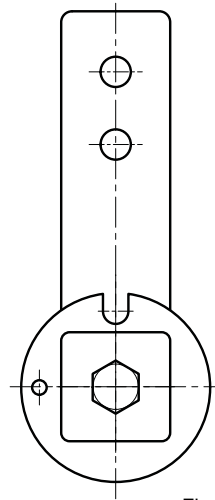

Fig.3

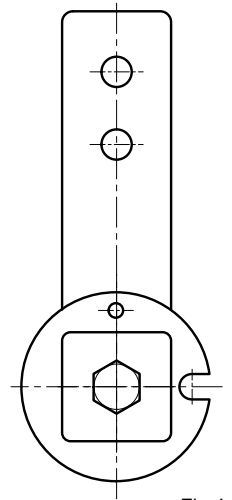

Fig.4

Type - *Tipo*: **EAQ**

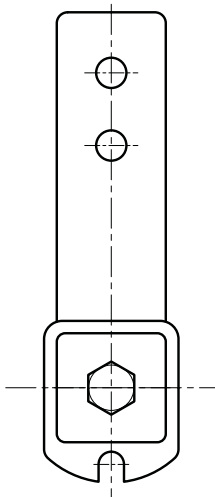

Fig.5

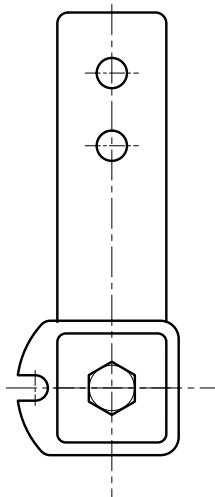

Fig.6

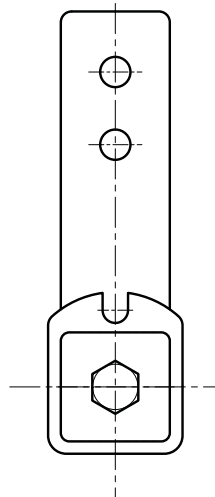

Fig.7

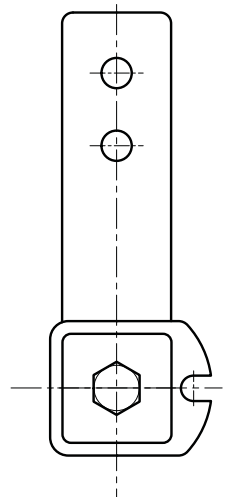

Fig.8

Type - *Tipo*: **EAS**

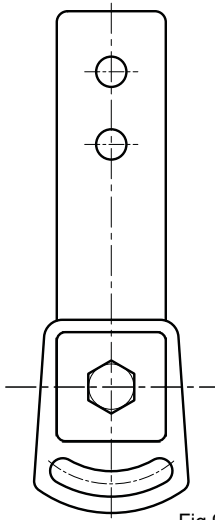

Fig.9

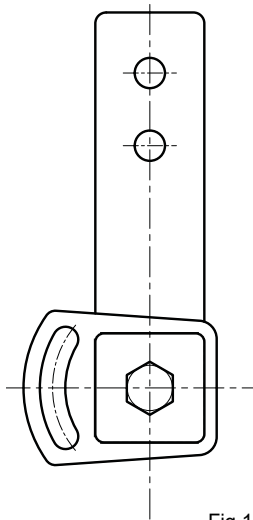

Fig.10

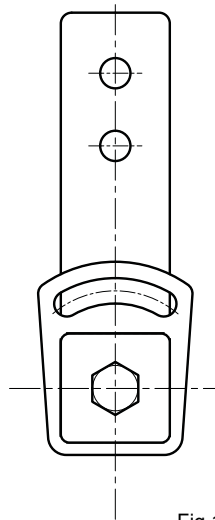

Fig.11

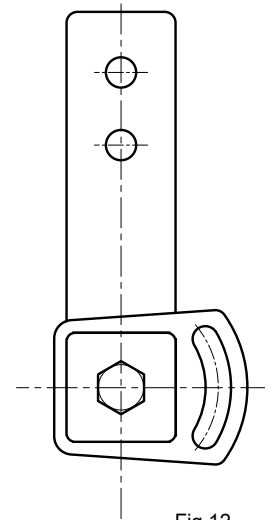

Fig.12



ECO: ELEMENTI ELASTICI SEMPLICI ED ECONOMICI

Gli elementi elastici ECO sono dei componenti semplici nella loro applicazione ed economicamente vantaggiosi. La robusta soluzione costruttiva è realizzata principalmente con profili tubolari in acciaio, ciò ci ha consentito di creare un prodotto robusto e concorrenziale su ogni mercato, senza rinunciare però alla qualità ed alle caratteristiche meccaniche dei tradizionali tenditori CRESA. Queste caratteristiche, anzi, sono migliorative e consentono numerose soluzioni costruttive ed applicative rispetto alle tecnologie note.

Gli articoli ECO come CRESA e CIAO, sono elementi elastici con funzionamento a rotazione. I tenditori ECO sfruttano la deformazione elastica di quattro cilindri di gomma naturale alloggiati nei vani risultanti dall'accoppiamento di due elementi a sezione quadrata ruotati di 45° uno rispetto all'altro. L'angolo di rotazione che può raggiungere è di $\pm 30^\circ$. Questo principio di funzionamento risulta, così, essere semplice, affidabile e silenzioso. Rispetto agli elementi elastici CRESA e CIAO, ECO, seppur avendo le medesime soluzioni di montaggio, vanta degli aspetti innovativi grazie all'uso degli anelli di contrasto (R, Q, S).

ECO trova spazio in moltissimi settori d'impiego e in particolar modo nelle applicazioni dove ci sia la necessità di tendere (tendicatena e tendicinghia), spingere (raschianastro) o pressare (pressori in generale).

Il programma ECO si sviluppa partendo dagli elementi elastici base EA (montaggio posteriore) e EF (montaggio frontale), a cui possono essere associati degli accessori antirotazione (R, Q, S). L'accessorio R è quello più comune pertanto sono stati inseriti a catalogo gli elementi EAR ed EFR già comprensivi sia di elemento elastico che di anello di contrasto.

A Pag.C-8 sono rappresentati gli elementi elastici BS e BSR da cui nascono gli elementi elastici EB e EBR con il montaggio di una leva realizzata in lamiera sagomata.

I prodotti ECO sono perfettamente intercambiabili per carico e geometria, viti di montaggio e dimensioni con gli articoli CRESA. Gli elementi elastici ECO, inoltre, se impiegati come tendicatena e tendicinghia possono montare tutti i kit d'interfaccia per catene e cinghie della serie CRESA, quindi: pattino in polietilene VR e OVR (Pag.C-32), rotella in polietilene RO (Pag.C-33), pignone tendicatena ZN, ZI (Pag.C-34) e ZK (Pag.C-35), rullo in poliammide RP (Pag.C-37, rullo in acciaio RU (Pag.C-38) e puleggia a gole SP (Pag.C-39).

I sistemi di montaggio e gli esempi di applicazione sono illustrati dalle pagine C-39 a C-41.

L'INNOVAZIONE DI ECO:

L'innovazione più rilevante di ECO rispetto alle tecniche note è la sua conformazione che può essere modificata a seconda delle esigenze operative. Partendo dai prodotti base tipo EA, EF ed EB questi possono essere implementati a seconda del bisogno costruttivo. Sia EA che EF ed EB sono perfettamente funzionanti e la forma quadrata della base di fissaggio garantisce l'ancoraggio stabile a parete sotto la pressione esercitata dalla vite di fissaggio. I tenditori possono essere abbinati a tre diversi anelli di contrasto (reazione) per garantire la stabilità rotazionale se in presenza di grandi forze radiali sulla leva. Questi elementi hanno forme diverse a seconda del bisogno applicativo, vedi esempi di applicazione.

Tutti gli anelli R, Q ed S possono essere montati indifferentemente sul corpo del tenditore su ogni lato dello stesso Pag. C-3 (Fig.1-12).

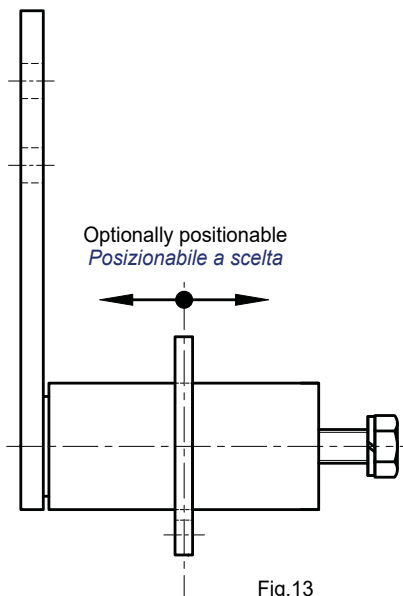



Fig.13

 The rings can be mounted on any axial position of the body depending on the construction needs (Fig.13), furthermore rings can be made with different shapes to satisfy the construction needs of the customers.

The BS and BSQ products on Page C-8 are also very interesting. All these can also be used with Q and S rings.

 Gli anelli possono essere montati su una qualsiasi posizione assiale del corpo a seconda delle necessità costruttive (Fig.13), inoltre possono essere realizzati anelli con forme diverse così da soddisfare le esigenze costruttive dei clienti.

Molto interessanti sono anche i prodotti BS e BSQ a Pag.C-8. Tutti questi possono essere impiegati anche con gli anelli Q ed S.

APPLICATION EXAMPLES ESEMPI DI APPLICAZIONE





Type - *Tipo*: **ECO EAR**

USE Tensioner device
Elemento tenditore

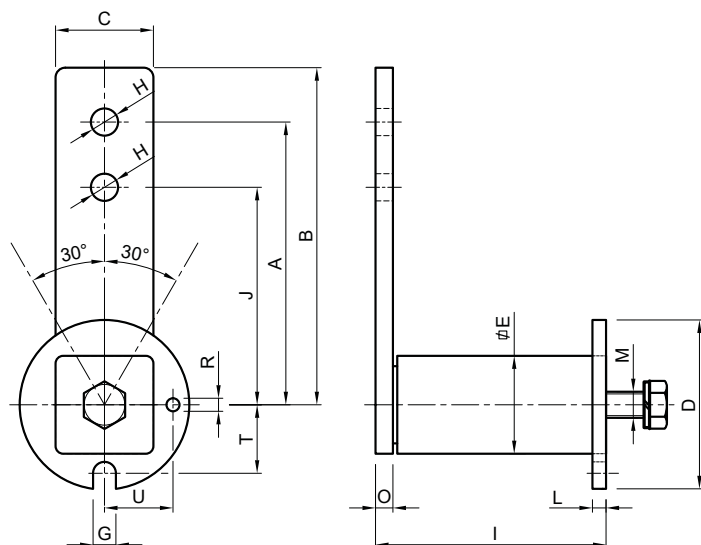

UK MATERIALS Steel.
TREATMENTS Tensioner: oven-painted. Ring: zinc plated.
USE Rotation angle $\pm 30^\circ$.
Operating temperature from -40°C to $+80^\circ\text{C}$.

IT MATERIALI Acciaio.
TRATTAMENTI Verniciatura a forno. Anello zincato.
IMPIEGO Angolo di rotazione $\pm 30^\circ$.
Temperatura di lavoro da -40°C a $+80^\circ\text{C}$.



Type <i>Tipo</i>	Cod. N°	A	B	C	D	E	G	ØH	I	J	L	M	O	R	T	U	Newton	Newton	Weight Peso (kg)	Type <i>Tipo</i>	Cod. N°	
																	0°-30°	0°-30°				
EAR 10	RE014010	80	90	20	35	20	8,0	8,5	50,5	+1,5 -0,5	60	3	M6	5	5	15,5	14,0	0+90	0+120	0,17	EA 10	RE014011
EAR 20	RE014020	100	112	27	45	27	8,5	10,5	62,5	+1,5 -0,5	80	4	M8	5	5	20,5	18,0	0+140	0+175	0,31	EA 20	RE014021
EAR 30	RE014030	100	115	32	58	32	8,5	10,5	77,0	+1,5 -0,5	80	5	M10	6	6	23,5	23,5	0+380	0+475	0,50	EA 30	RE014031
EAR 40	RE014040	130	155	45	78	45	10,5	12,5	106,0	+2,0 -1,0	100	8	M12	8	6	31,5	31,5	0+860	0+1118	1,20	EA 40	RE014041
EAR 50	RE014050	175	205	60	95	60	12,5	20,5	140,0	+2,0 -1,0	140	10	M16	10	6	41,5	41,5	0+1600	0+2000	2,49	EA 50	RE014051
EAR 60	RE014060	225	260	75	115	75	12,5	20,5	199,0	+2,5 -1,5	180	12	M20	12	8	50,0	50,0	0+2700	0+3375	4,92	EA 60	RE014061
EAR 70	RE014070	250	290	80	130	80	17,0	20,5	209,0	+2,5 -1,5	200	12	M24	20	10	56,0	56,0	0+4400	0+5500	8,38	EA 70	RE014071

Type - *Tipo*: **ECO EA**

USE Tensioner device
Elemento tenditore

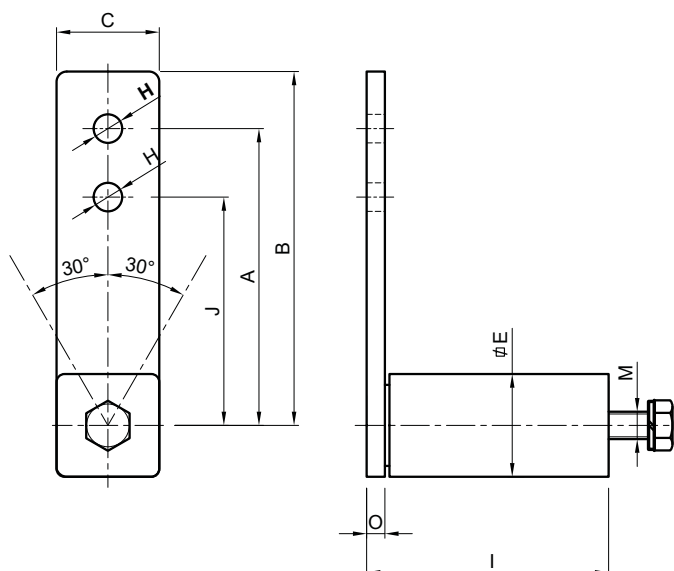

UK MATERIALS Steel.
TREATMENTS Tensioner: oven-painted.
USE Rotation angle $\pm 30^\circ$.
Operating temperature from -40°C to $+80^\circ\text{C}$.

IT MATERIALI Acciaio.
TRATTAMENTI Verniciatura a forno.
IMPIEGO Angolo di rotazione $\pm 30^\circ$.
Temperatura di lavoro da -40°C a $+80^\circ\text{C}$.



Type - *Tipo*: **ECO EFR**

USE Front mounting
Montaggio frontale

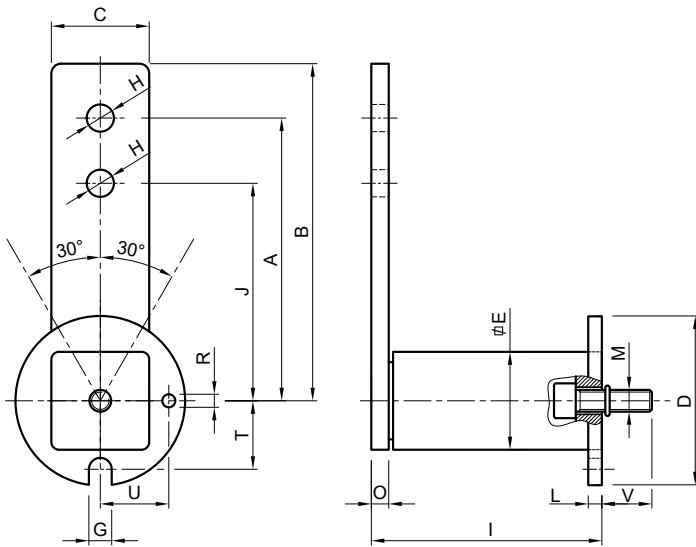

UK MATERIALS Steel.
TREATMENTS Tensioner: oven-painted. Ring: zinc plated.
USE Rotation angle $\pm 30^\circ$.
Operating temperature from -40°C to $+80^\circ\text{C}$.

IT MATERIALI Acciaio.
TRATTAMENTI Verniciatura a forno. Anello zincato.
IMPIEGO Angolo di rotazione $\pm 30^\circ$.
Temperatura di lavoro da -40°C a $+80^\circ\text{C}$.



Type <i>Tipo</i>	Cod. N°	A	B	C	D	E	G	ØH	I	J	L	M	O	R	T	U	V	Newton 0°-30° Arm Braccio (A)	Newton 0°-30° Arm Braccio (J)	Weight Peso (kg)	Type <i>Tipo</i>	Cod. N°
EFR 10	RE014110	80	90	20	35	20	8,0	8,5	50,5 ^{+1,5} _{-0,5}	60	3	M5	5	5	15,5	14,0	10	0÷90	0÷120	0,17	EF 10	RE014111
EFR 20	RE014120	100	112	27	45	27	8,5	10,5	62,5 ^{+1,5} _{-0,5}	80	4	M6	5	5	20,5	18,0	10	0÷140	0÷175	0,31	EF 20	RE014121
EFR 30	RE014130	100	115	32	58	32	8,5	10,5	77,0 ^{+1,5} _{-0,5}	80	5	M8	6	6	23,5	23,5	15	0÷380	0÷475	0,50	EF 30	RE014131
EFR 40	RE014140	130	155	45	78	45	10,5	12,5	106,0 ^{+2,0} _{-1,0}	100	8	M10	8	6	31,5	31,5	18	0÷860	0÷1118	1,20	EF 40	RE014141
EFR 50	RE014150	175	205	60	95	60	12,5	20,5	140,0 ^{+2,0} _{-1,0}	140	10	M12	10	6	41,5	41,5	23	0÷1600	0÷2000	2,49	EF 50	RE014151
EFR 60	RE014160	225	260	75	115	75	12,5	20,5	199,0 ^{+2,5} _{-1,5}	180	12	M16	12	8	50,0	50,0	25	0÷2700	0÷3375	4,92	EF 60	RE014161
EFR 70	RE014170	250	290	80	130	80	17,0	20,5	209,0 ^{+2,5} _{-1,5}	200	12	M20	20	10	56,0	56,0	25	0÷4400	0÷5500	8,38	EF 70	RE014171

Type - *Tipo*: **ECO EF**

USE Front mounting
Montaggio frontale

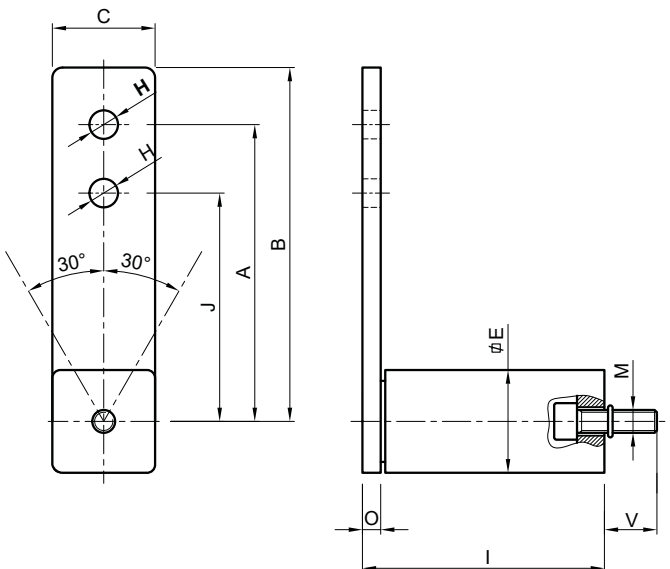

UK MATERIALS Steel.
TREATMENTS Oven-painted.
USE Rotation angle $\pm 30^\circ$.
Operating temperature from -40°C to $+80^\circ\text{C}$.

IT MATERIALI Acciaio.
TRATTAMENTI Verniciatura a forno.
IMPIEGO Angolo di rotazione $\pm 30^\circ$.
Temperatura di lavoro da -40°C a $+80^\circ\text{C}$.



Type - *Tipo*: **ECO EBR**

USE Tensioner device - Shaped lever
Elemento tenditore - Leva sagomata

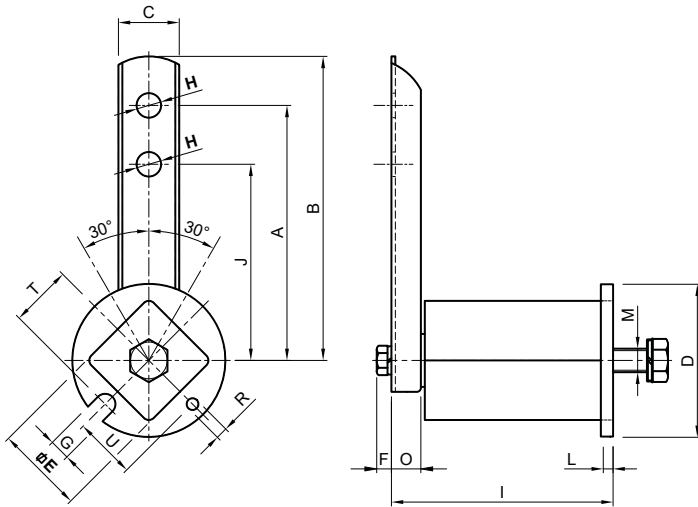

UK MATERIALS Steel/Aluminium .
TREATMENTS Tensioner: oven-painted. Lever and ring: zinc plated.
USE Rotation angle $\pm 30^\circ$.
Operating temperature from -40°C to $+80^\circ\text{C}$.

IT MATERIALI Acciaio/Alluminio.
TRATTAMENTI Verniciatura a forno. Leva ed anello zincati.
IMPIEGO Angolo di rotazione $\pm 30^\circ$.
Temperatura di lavoro da -40°C a $+80^\circ\text{C}$.



Type <i>Tipo</i>	Cod. N°	A	B	C	D	E	F	G	ØH	I	J	L	M	O	R	T	U	Newton	Newton	Weight Peso (kg)	Type <i>Tipo</i>	Cod. N°
																		0°-30°	0°-30°			
																		Arm Braccio (A)	Arm Braccio (J)			
EBR 10	RE014210	80	90	13	35	20	5,6	8,0	8,5	54,5 ^{+1,5} _{-0,5}	60	3	M6	9,5	5	15,5	14,0	0+90	0+120	0,17	EB 10	RE014211
EBR 20	RE014220	100	112	18	45	27	5,6	8,5	10,5	66,5 ^{+1,5} _{-0,5}	80	4	M8	10	5	20,5	18,0	0+140	0+175	0,31	EB 20	RE014221
EBR 30	RE014230	100	115	22	58	32	5,6	8,5	10,5	80,0 ^{+1,5} _{-0,5}	80	5	M10	10	6	23,5	23,5	0+380	0+475	0,50	EB 30	RE014231
EBR 40	RE014240	130	155	31	78	45	7,5	10,5	12,5	112,0 ^{+2,0} _{-1,0}	100	8	M12	15	6	31,5	31,5	0+860	0+1118	1,20	EB 40	RE014241
EBR 50	RE014250	175	205	45	95	60	9,2	12,5	20,5	142,0 ^{+2,0} _{-1,0}	140	10	M16	15	6	41,5	41,5	0+1600	0+2000	2,49	EB 50	RE014251
EBR 60	RE014260	225	260	51	115	72	10,5	12,5	20,5	199,0 ^{+2,5} _{-1,5}	180	12	M20	16	8	50,0	50,0	0+2700	0+3375	4,92	EB 60	RE014261
EBR 70	RE014270	250	290	58	130	80	13,5	17,0	20,5	199,0 ^{+2,5} _{-1,5}	200	12	M24	16	10	56,0	56,0	0+4400	0+5500	8,38	EB 70	RE014271

Type - *Tipo*: **ECO EB**

USE Tensioner device - Shaped lever
Elemento tenditore - Leva sagomata

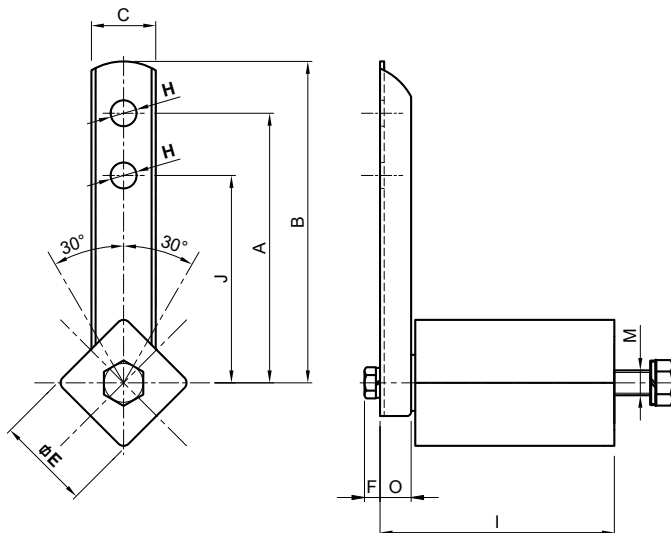

UK MATERIALS Steel/Aluminium .
TREATMENTS Tensioner: oven-painted. Lever zinc plated.
USE Rotation angle $\pm 30^\circ$.
Operating temperature from -40°C to $+80^\circ\text{C}$.

IT MATERIALI Acciaio/Alluminio.
TRATTAMENTI Verniciatura a forno. Leva zincata.
IMPIEGO Angolo di rotazione $\pm 30^\circ$.
Temperatura di lavoro da -40°C a $+80^\circ\text{C}$.

Type - *Tipo*: ECO BSR

USE Base
Base

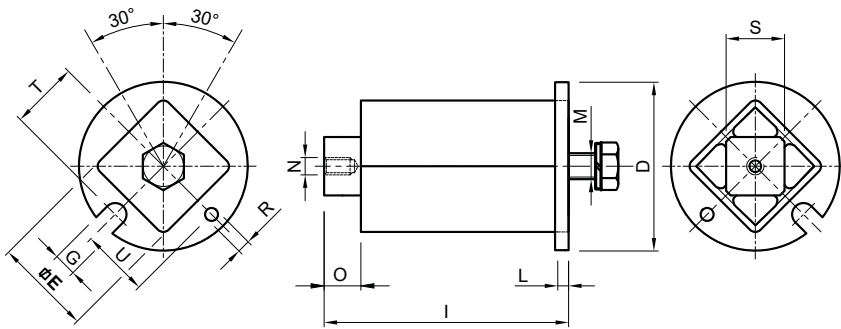

UK MATERIALS Steel/Aluminium.
TREATMENTS Tensioner: oven-painted. Ring: zinc plated.
USE Rotation angle $\pm 30^\circ$.
 Operating temperature from -40°C to $+80^\circ\text{C}$.

IT MATERIALI Acciaio/Alluminio.
TRATTAMENTI Verniciatura a forno. Anello zincato.
IMPIEGO Angolo di rotazione $\pm 30^\circ$.
 Temperatura di lavoro da -40°C a $+80^\circ\text{C}$.



Type <i>Tipo</i>	Cod. N°	D	E	G	I	L	M	N	O	R	S	T	U	Newton 0°-30°		Weight Peso (kg)	Type <i>Tipo</i>	Cod. N°
														Arm Braccio (A)	Arm Braccio (J)			
BSR 10	RE014310	35	20	8,0	53,5 ^{+1,5} _{-0,5}	3	M6	M6	9,5	5	11	15,5	14,0	0÷90	0÷120	0,11	BS 10	RE014311
BSR 20	RE014320	45	27	8,5	65,0 ^{+1,5} _{-0,5}	4	M8	M6	9,0	5	15	20,5	18,0	0÷140	0÷175	0,23	BS 20	RE014321
BSR 30	RE014330	58	32	8,5	78,0 ^{+1,5} _{-0,5}	5	M10	M6	9,0	6	18	23,5	23,5	0÷380	0÷475	0,50	BS 30	RE014331
BSR 40	RE014340	78	45	10,5	110,0 ^{+2,0} _{-1,0}	8	M12	M8	14,0	6	27	31,5	31,5	0÷860	0÷1118	1,03	BS 40	RE014341
BSR 50	RE014350	95	60	12,5	140,0 ^{+2,0} _{-1,0}	10	M16	M10	14,5	6	40	41,5	41,5	0÷1600	0÷2000	2,39	BS 50	RE014351
BSR 60	RE014360	115	72	12,5	196,0 ^{+2,5} _{-1,5}	12	M20	M12	14,0	8	45	50,0	50,0	0÷2700	0÷3375	4,97	BS 60	RE014361
BSR 70	RE014370	130	80	17,0	195,0 ^{+2,5} _{-1,5}	12	M24	M16	15,0	10	50	56,0	56,0	0÷4400	0÷5500	6,46	BS 70	RE014371

Type - *Tipo*: ECO BS

USE Base
Base

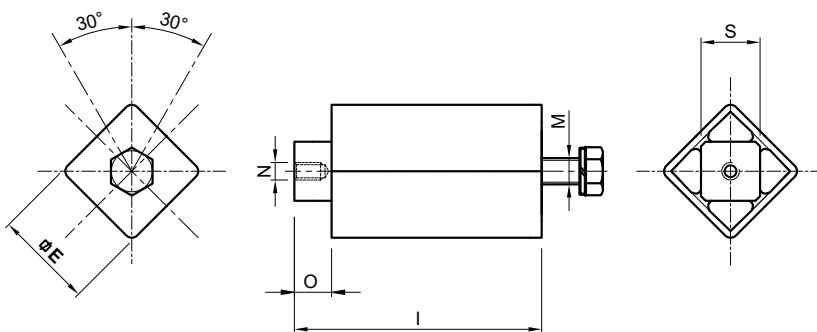

UK MATERIALS Steel/Aluminium.
TREATMENTS Tensioner: oven-painted.
USE Rotation angle $\pm 30^\circ$.
 Operating temperature from -40°C to $+80^\circ\text{C}$.

IT MATERIALI Acciaio/Alluminio.
TRATTAMENTI Verniciatura a forno.
IMPIEGO Angolo di rotazione $\pm 30^\circ$.
 Temperatura di lavoro da -40°C a $+80^\circ\text{C}$.



Type - *Tipo*: **ECO BL**

USE Shaped lever
Leva sagomata

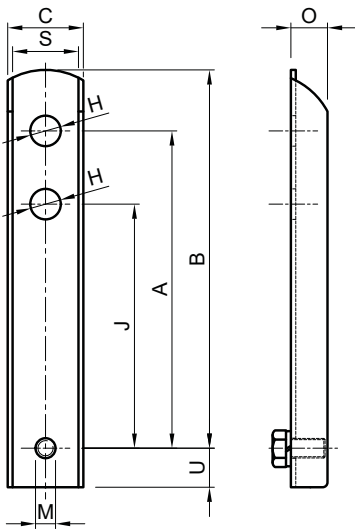

 **MATERIALS** Steel.
TREATMENTS Galvanization.
USE Reaction lever.

 **MATERIALI** Acciaio.
TRATTAMENTI Zincatura elettrolitica.
IMPIEGO Leva di reazione.



Type <i>Tipo</i>	Cod. N°	A	B	C	ØH	J	M	O	ØP	S	U	Weight Peso (kg)
BL 10	RE014212	80	90	13	8,5	60	M6x10	9,5	6,5	11	7	0,06
BL 20	RE014222	100	112	18	10,5	80	M6x10	10	6,5	15	9	0,08
BL 30	RE014232	100	115	22	10,5	80	M6x10	10	6,5	18	11	0,10
BL 40	RE014242	130	155	31	12,5	100	M8x12	15	8,5	27	16	0,40
BL 50	RE014252	175	205	48	20,5	140	M10x16	15	10,5	40	20	0,50
BL 60	RE014262	225	260	51	20,5	180	M12x16	16	12,5	45	25,5	0,60
BL 70	RE014272	250	290	58	20,5	200	M16x25	16	16,5	50	28	0,90

Contrast ring - Anello di contrasto

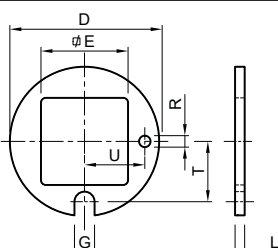
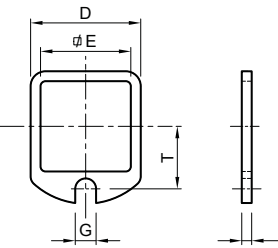
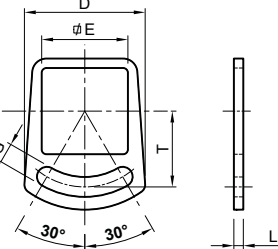
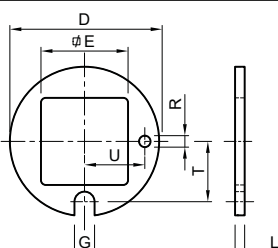
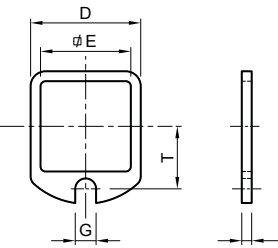
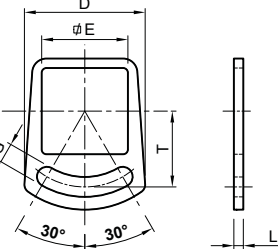
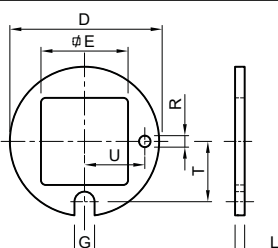
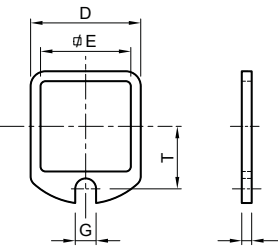
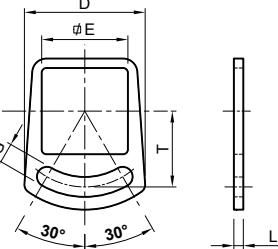
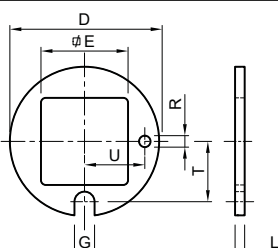
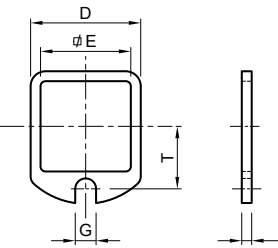
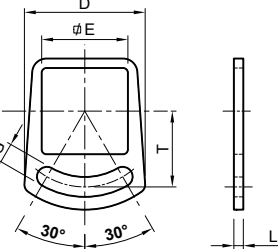
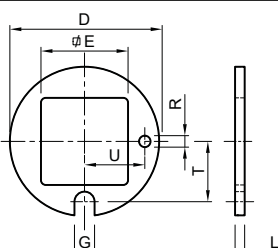
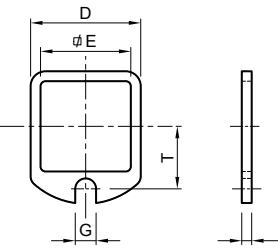
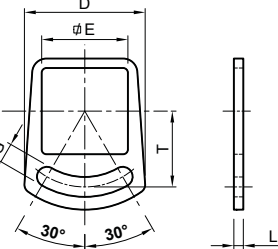
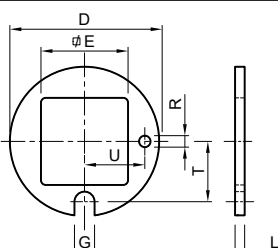
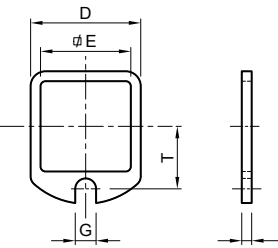
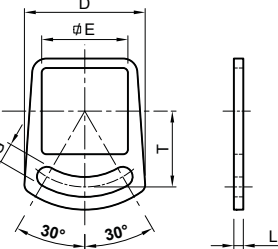
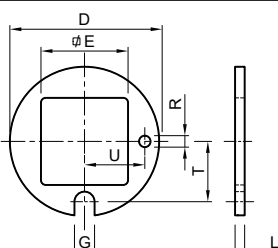
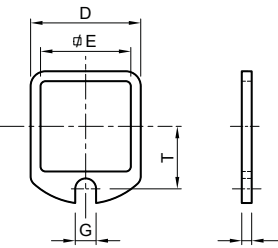
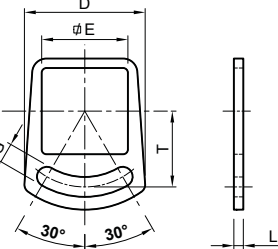
Type <i>Tipo</i>	Cod. N°	D	E	G	L	R	T	U	Weight Peso (kg)
	R 10 RE014401	35,0	20	8,0	3	5	15,5	14,0	0,02
	R 20 RE014402	45,0	27	8,5	4	5	20,5	18,0	0,03
	R 30 RE014403	58,0	32	8,5	5	6	23,5	23,5	0,06
	R 40 RE014404	78,0	45	10,5	8	6	31,5	31,5	0,10
	R 50 RE014405	95,0	60	12,5	10	6	41,5	41,5	0,13
	R 60 RE014406	115,0	75	12,5	12	8	50,0	50,0	0,18
	R 70 RE014407	130,0	80	17,0	12	10	56,0	56,0	0,26
	Q 10 RE014411	26,5	20	8,0	3	-	15,5	-	0,01
	Q 20 RE014412	35,5	27	8,5	4	-	20,5	-	0,02
	Q 30 RE014413	42,5	32	8,5	5	-	23,5	-	0,03
	Q 40 RE014414	55,5	45	10,5	8	-	31,5	-	0,06
	Q 50 RE014415	72,5	60	12,5	10	-	41,5	-	0,08
	Q 60 RE014416	89,5	75	12,5	12	-	50,0	-	0,11
	Q 70 RE014417	106,5	80	17,0	12	-	56,0	-	0,15
	S 10 RE014421	37,0	20	8,5	3	-	22,0	-	0,02
	S 20 RE014422	40,0	27	8,5	4	-	25,0	-	0,03
	S 30 RE014423	51,0	32	8,5	5	-	30,0	-	0,05
	S 40 RE014424	64,0	45	10,5	8	-	40,0	-	0,08
	S 50 RE014425	87,0	60	12,5	10	-	50,0	-	0,11
	S 60 RE014426	104,0	75	12,5	12	-	58,0	-	0,16
	S 70 RE014427	126,0	80	17,0	12	-	71,0	-	0,21

 **MATERIALS** Steel. **TREATMENTS** Galvanization. **USE** Antirotation clamp.

 **MATERIALI** Acciaio. **TRATTAMENTI** Zincatura elettrolitica. **IMPIEGO** Piastrina antirotazione.

UNIT OF MEASURE: CONVERSIONS UNITÀ DI MISURA: CONVERSIONI

Size <i>Grandezza</i>	Symbol <i>Simbolo</i>	SI International System <i>Sistema Internazionale SI</i>		Technical Metric System <i>Sistema Tecnico Metrico</i>			English Technical System <i>Sistema Tecnico Inglese</i>		
		Unit <i>Unità</i>	Symbol <i>Simbolo</i>	Unit <i>Unità</i>	Symbol <i>Simbolo</i>	Conversion <i>Conversione</i> SI	Unit <i>Unità</i>	Symbol <i>Simbolo</i>	Conversion <i>Conversione</i> SI
Length <i>Lunghezza</i>	l	Meter <i>Metro</i>	m	Meter <i>Metro</i>	m	-	Foot <i>Piede</i>	ft	x 3,3
							Inch <i>Pollice</i>	in	x 39,37
Surface <i>Superficie</i>	A	Square meter <i>Metro quadrato</i>	m ²	Square meter <i>Metro quadrato</i>	m ²	-	Square inch <i>Pollice quadrato</i>	in ²	x 1550,39
Volume <i>Volume</i>	V	Cubic meter <i>Metro cubo</i>	m ³	Cubic meter <i>Metro cubo</i>	m ³	-	Cubic inch <i>Pollice cubo</i>	in ³	x 61012,81
							Gallon <i>Gallone</i>	gal	x 219,974
Time <i>Tempo</i>	t	Second <i>Secondo</i>	s	Second <i>Secondo</i>	s	-	Minute <i>Minuto</i>	min	x 60
Speed <i>Velocità</i>	v	Meter per second <i>Metro al secondo</i>	m/s	Meter per minute <i>Metro al minuto</i>	m/min	x 60	Foot per second <i>Piede al secondo</i>	ft/s	x 3,3
Acceleration <i>Accelerazione</i>	a	Meter per second squared <i>Metro al secondo quadrato</i>	m/s ²	Meter per second squared <i>Metro al secondo quadrato</i>	m/s ²	-	Foot per second square <i>Piede al secondo quadrato</i>	ft/s ²	x 3,3
Angular speed <i>Velocità angolare</i>	ω	Rediant per second <i>Radiante al secondo</i>	rad/s	Rediant per second <i>Radiante al secondo</i>	rad/s	-	Radiant per second <i>Radiante al secondo</i>	rad/s	-
Rotation speed <i>Velocità di rotazione</i>	n	Second ⁻¹ <i>Secondo⁻¹</i>	1/s	Revolution per minute <i>Giro al minuto</i>	1/min	x 60	Round per minutes <i>Giri al minuto</i>	rpm	x 60
Mass <i>Massa</i>	m	Kilogram <i>Kilogrammo</i>	Kg	Kg second squared per meter <i>Kg secondo quadrato al metro</i>	K _p s ² /m	-	Pound (mass) <i>Libbra (massa)</i>	lb	-
Force <i>Forza</i>	F	Newton <i>Newton</i>	N	Kilogram <i>Kilogrammo</i>	K _p	x 0,10194	Puond (weight) <i>Libbra (peso)</i>	lbf	x 2,205
Density <i>Densità</i>	ρ	Kilogram per cubic meter <i>Kilogrammo al metro cubo</i>	Kg/m ³	-	-	-	Pound to the cubic inch <i>Libbra al pollice cubo</i>	lb/in ³	x 3,6x10 ⁻⁵
Specific weight <i>Peso specifico</i>	γ	-	-	Kilogram per cubic meter <i>Kilogrammo al metro cubo</i>	K _p /m ³	-	Pound to the cubic inch <i>Libbra al pollice cubo</i>	lb/in ³	-
Moment <i>Momento</i>	M	Newton meter <i>Newton metro</i>	Nm	Kilogram meter <i>Kilogrammo metro</i>	K _p m	x 0,10194	Pound foot <i>Libbra piede</i>	lbf · ft	x 0,73746
Work <i>Lavoro</i>	W	Joule <i>Joule</i>	J	Kilogram meter <i>Kilogrammo metro</i>	K _p m	x 0,10194	Pound foot <i>Libbra piede</i>	lbf · ft	x 0,73746
Power <i>Potenza</i>	P	Watt <i>Watt</i>	W	Kilogrammeter per second <i>Kilogrammetro al secondo</i>	K _p m/s	x 0,10194	Pound foot per second <i>Libbra Piede al secondo</i>	lbf · ft/s	x 0,73746
							Horse-Power <i>Horse-power</i>	hp	x 1,341x10 ⁻³
Temperature <i>Temperatura</i>	T	Kelvin degree <i>Grado Kelvin</i>	K	Degree Celsius <i>Grado Celsius</i>	°C	K-273,15	Fahrenheit degree <i>Grado Fahrenheit</i>	°F	(K-255,37)