

C

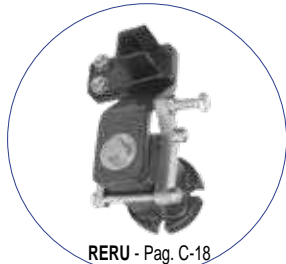

RER - Pag. C-18



RER - Pag. C-18



RE - Pag. C-19



REP - Pag. C-19

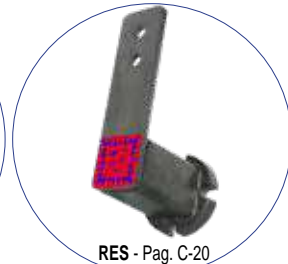

RES - Pag. C-20



RESP - Pag. C-20



FE - Pag. C-21

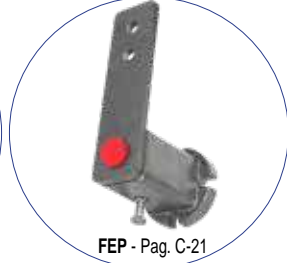

FEP - Pag. C-21



BE - Pag. C-22



BEP - Pag. C-22



ME - Pag. C-23



MEP - Pag. C-23



REG - Pag. C-24



REZ - Pag. C-24



REX - Pag. C-24



CEA/CEAP
Pag. C-25



CEB/CEBP
Pag. C-25



CET/CETP
Pag. C-26



CEP/CEPP
Pag. C-26



FM - Pag. C-27

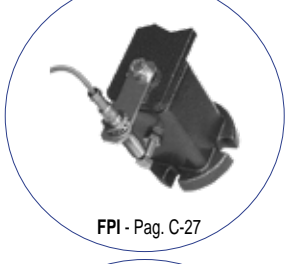

FPI - Pag. C-27



SU - Pag. C-28



ST - Pag. C-28

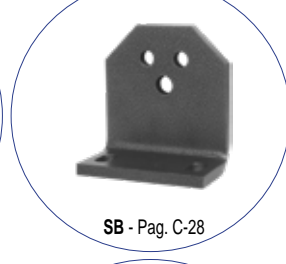

SB - Pag. C-28

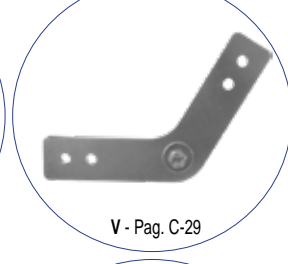

V - Pag. C-29



PR - Pag. C-29



SAR - Pag. C-30



VR - Pag. C-32



OVR - Pag. C-32



RO - Pag. C-33



ZN Pag. C-34



ZK / K - Pag. C-35



RP - Pag. C-37



RU - Pag. C-38



SP - Pag. C-39

🇬🇧 AUTOMATIC TORSIONAL TENSIONERS, ISTRUZIONE CORRECT FOR USE:

Roller chains (transmission or transport) and belts are part of the series of mechanical systems called enveloping flexible elements which share the characteristic of reacting only to tensile stress. These mechanical parts are generally used to transmit power between two rotating hubs, but they may also be used to carry or lift objects. For a correct use of enveloping flexible elements, it is necessary, while designing, to contemplate a system for keeping these units always tensioned during operation. It is therefore inevitable to equip the transmission with an automatic chain tensioner, to recover the stretching and constantly absorb vibrations. Automatic torsional chain tensioners must be placed on the loose part of the transmission, as close as possible to the drive pinion.

Mounting scheme:

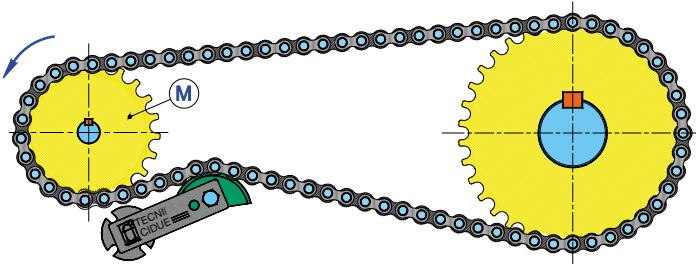

Fig.9 **CORRECT** mounting (RECOMMENDED!)

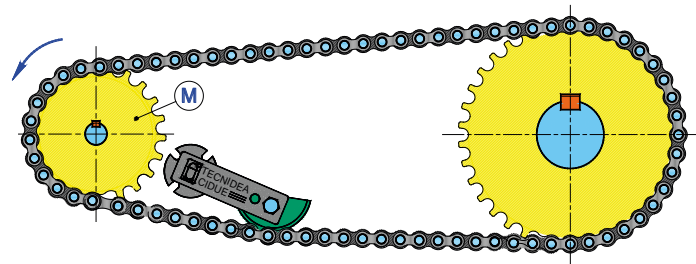

Fig.10 **CORRECT** mounting

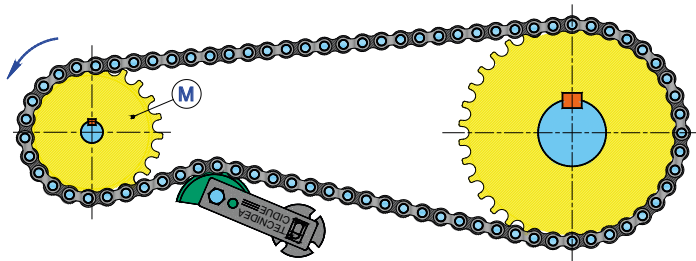

Fig.11 **CORRECT** mounting (NOT RECOMMENDED!)

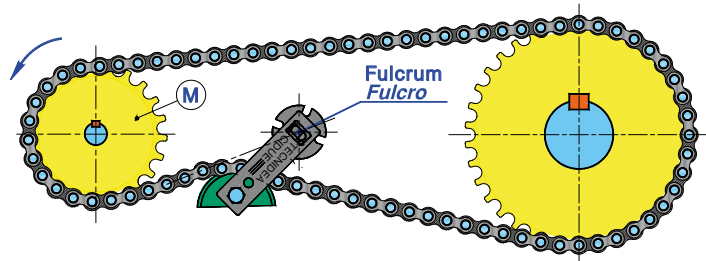

Fig.12 **WRONG** mounting

On reversing drive transmission, you will have to place a tensioner on both sections at the output of the driving pinion (Fig.13). In this case you will have to take care to put the chain tensioners in a manner that when they work, alternatively, on the tight section of the transmission, they will not have to exceed the maximum working angle allowed by the elastic element, due by the alignment of the chain during the stretched phase.

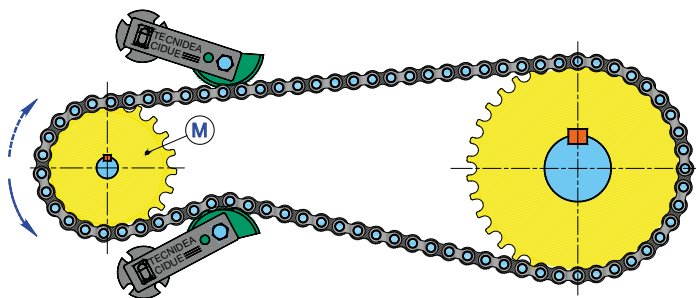

Fig.13 Tensioning for reversing drive

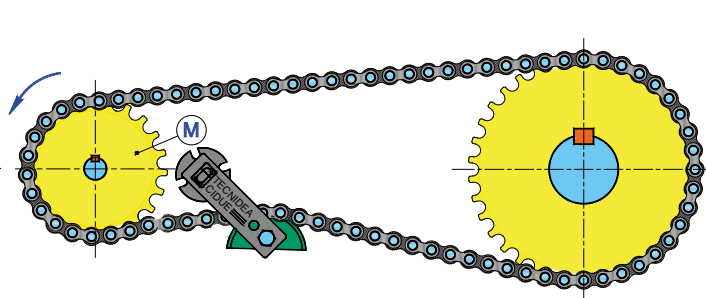

Fig.14 Tensioning with internal tensioner

When a transmission has a long distance between centres, often happens that a tensioner has not enough travel to recover all the stretch of the chain, but with a "S" winding (Fig.15), available on rotational tensioners only, it is possible to do it with one elastic element only.

UK **Tensioning for high center distance:**

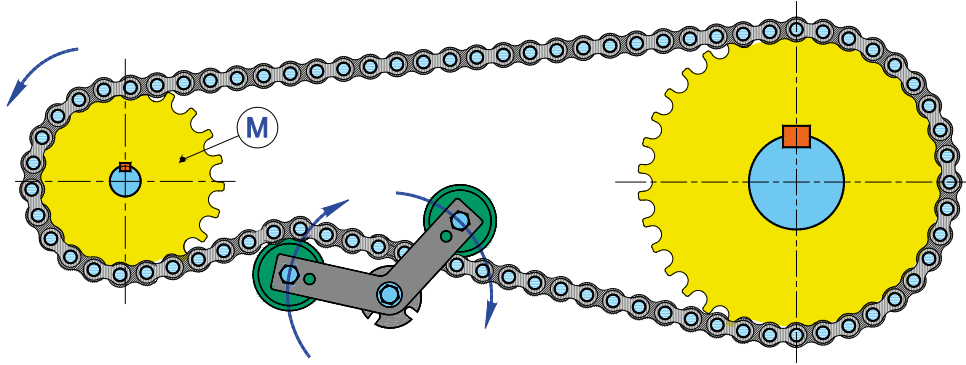

Fig.15 "S" Tensioning

In a chain or belt tensioner the most "delicate" point is the fulcrum "F", where it rotates. In this particular zone, in fact, the frictions appear for the rubbing of parts that are in contact each other.

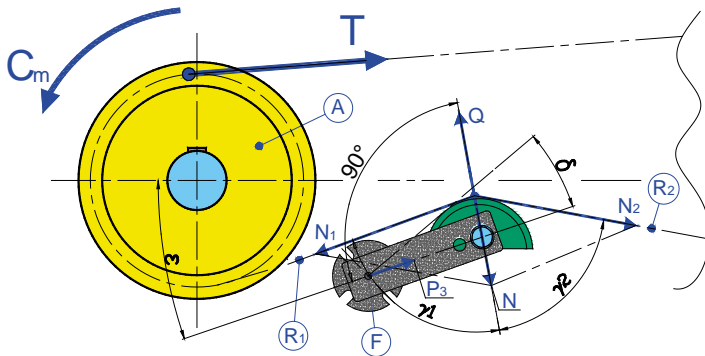

Fig.17 Forces Distribution

- A = Driving sprocket
- T = Tension on the tensed area
- C_m = Motor torque
- R₁ = Section of chain entering operating area
- R₂ = Section of chain leaving operating area
- F = Fulcrum or point of rotation
- Q = Force released by the tensioner
- N = Chain reaction force
- N₁ = Component of N on section R₁
- N₂ = Component of N on section R₂
- P₃ = Spring axial compression force
- δ = Tensioner working angle
- ε = Tensioner positioning angle
- γ_{1,2} = Entering and leaving chain angle

A tensioner releases a force Q (Fig.17) perpendicular to the rotational arm that, by reaction, is balanced by the chain with the force N which is distributed with the traction forces N₁ and N₂ on the sections entering and leaving the tensioner, respectively R₁ and R₂. When positioning a chain tensioner, you must ensure that the forces Q and N are as much as possible on the same line so that there is no formation of tangential components which would be discharged on the fulcrum. In case of CRESA tensioners, these undesired tangential forces are cancelled by the P₃ axial compression force of the rubber spring. The positioning of the tensioner therefore depends on the angle δ, that is the working angle of the elastic element, and on the angle ε, that is the positioning angle with respect to the transmission. So the designer must find the right ratio between these parameters according to the geometry of his transmission.

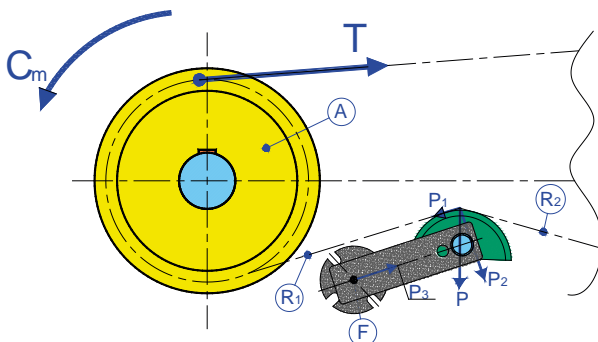

Fig.18 Forces Distribution

- A = Driving sprocket
- T = Tension on the tensed area
- C_m = Motor torque
- R₁ = Section of chain entering tensioner operating area
- R₂ = Section of chain leaving tensioner operating area
- F = Fulcrum or point of rotation
- P = Weight force
- P₁ = Tangential component of P
- P₂ = Normal component of P
- P₃ = Rubber - Spring compression force

Fig.18 shows the influence of the weight force P of the chain on the tensioner in horizontal transmissions. The chain weight, especially in chains with high specific weight by meter and with long distance between centres of transmission sprockets, is divided on the tensioner into force P₂ normal to the lever and a force P₁ tangential to the lever. This compression element is balanced by the rubber-spring compression force P₃.

UK **MATERIALS USED:**

- (a) - Body: Size 10-20-30-70 steel. 40-50-60 cast iron.
- (b) - Lever: Steel
- Rubber: GOBA (unless otherwise specified)
- Treatments: Oven painting. Galvanized screws.
- Use: Working temperature from -40°C to +80°C.

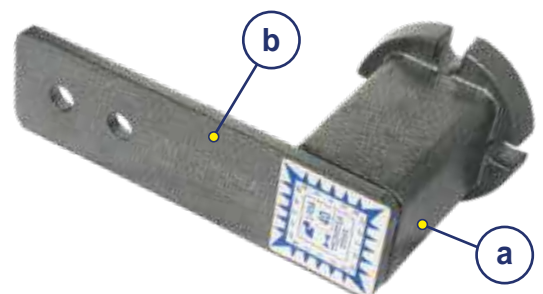

TENDITORI AUTOMATICI A ROTAZIONE, CONSIGLI PER UN CORRETTO UTILIZZO:

Le catene a rulli e le cinghie fanno parte di quella serie di organi meccanici chiamati *elementi flessibili ad involuppo* e vengono generalmente utilizzati per trasmettere potenza tra due mozzi rotanti, ma possono essere utilizzati anche per il trasporto o il sollevamento di oggetti. Per un corretto utilizzo degli elementi flessibili ad involuppo è necessario prevedere, in fase di progettazione, un sistema per mantenere sempre in tensione queste unità durante il loro funzionamento. Inevitabile risulta, quindi, equipaggiare la trasmissione di un tendicatena automatico, che permetta di recuperare gli allungamenti e assorbire costantemente le vibrazioni. I tendicatena automatici a rotazione devono essere posizionati sul tratto lento della trasmissione il più vicino possibile al pignone motore.

Schema di montaggio

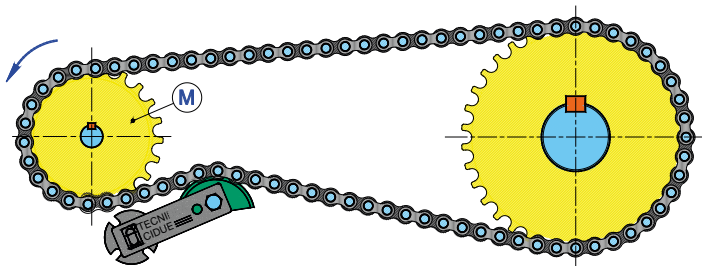

Fig.9 Montaggio **CORRETTO** (CONSIGLIATO!)

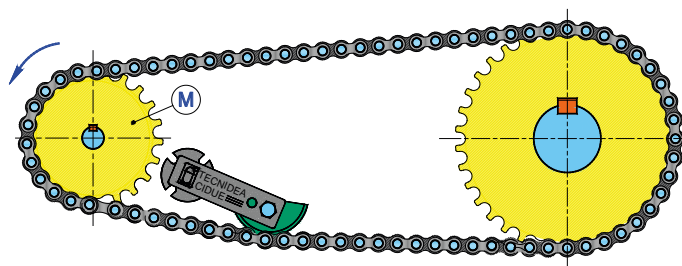

Fig.10 Montaggio **CORRETTO**

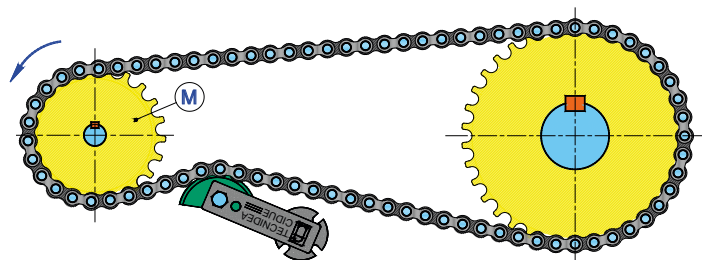

Fig.11 Montaggio **CORRETTO** (SCONSIGLIATO!)

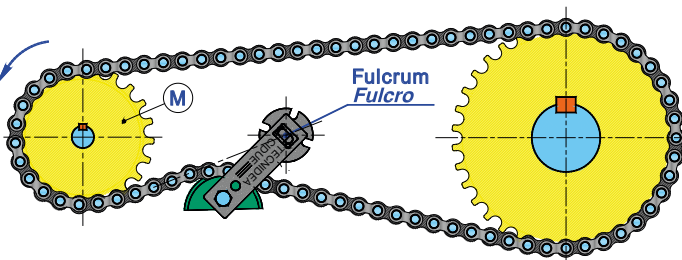

Fig.12 Montaggio **ERRATO**

Nel caso di una trasmissione a doppio senso di marcia, dovrà essere posizionato un tenditore su entrambi i rami della catena all'uscita dal pignone motore (Fig.13). In questo caso si dovrà aver cura nel posizionare i tendicatena in maniera tale che quando agiscono, alternativamente, sul ramo teso della trasmissione non devono oltrepassare l'angolo massimo di lavoro consentito dall'elemento elastico, dovuto all'allineamento della catena in fase di tiro.

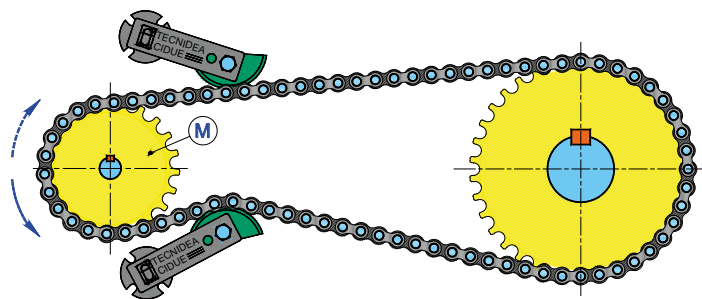

Fig.13 Tensionamento per movimenti reversibili

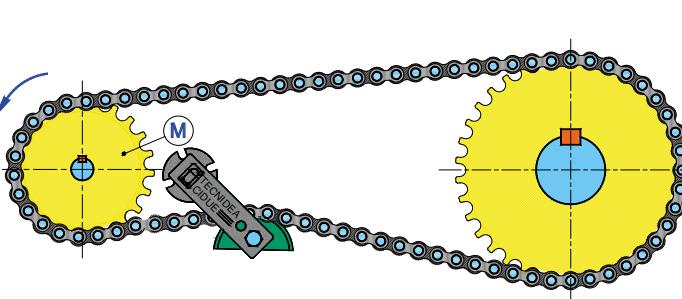

Fig.14 Tensionamento con tenditore interno

Nel caso in cui la trasmissione presenti un elevato interasse, spesso capita che un tenditore non abbia sufficiente corsa per recuperare tutto l'allungamento della catena, ma con un avvolgimento a "S" (Fig.15), fattibile solamente con i tenditori a rotazione, è possibile riuscirci con un unico elemento elastico.

Tensionamento per interassi elevati:

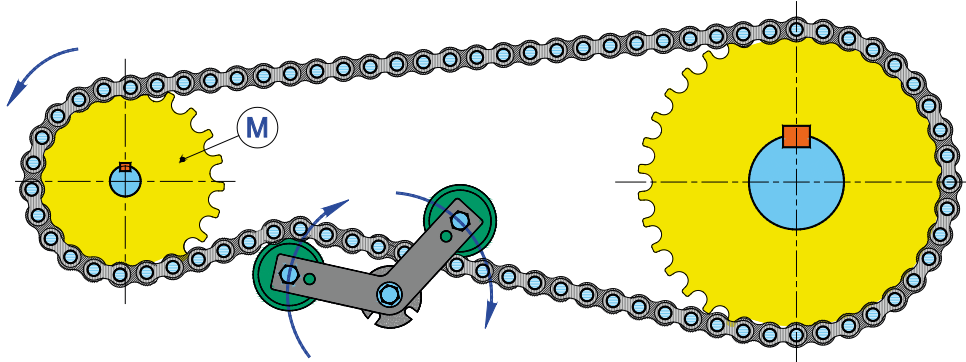

Fig.15 Tensionamento a "S"

In un tendicatena (o tendicinghia) il punto più "delicato" è il fulcro "F", ovvero il punto dove avviene la rotazione. In questa particolare zona, infatti, si manifestano gli attriti per sfregamento di particolari in contatto tra loro.

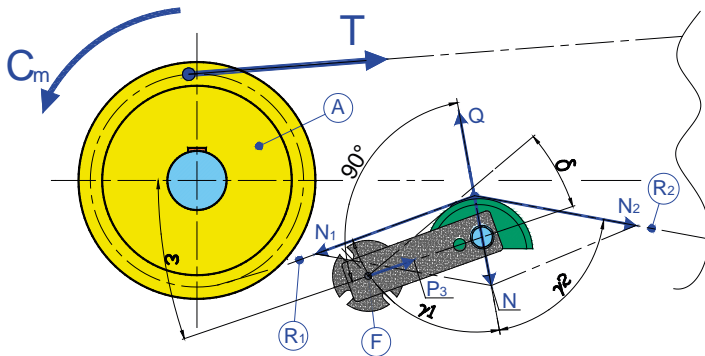

Fig.17 Distribuzione delle forze

- A = Ruota dentata motrice
- T = Tensione sul ramo teso
- C_m = Coppia motrice
- R₁ = Ramo della catena in entrata
- R₂ = Ramo della catena in uscita
- F = Fulcro o punto di rotazione
- Q = Forza sprigionata dal tenditore
- N = Forza di reazione della catena
- N₁ = Componente di N sul ramo R₁
- N₂ = Componente di N sul ramo R₂
- P₃ = Forza di compressione assiale della molla
- δ = Angolo di lavoro del tenditore
- ε = Angolo di posizionamento del tenditore
- γ_{1,2} = Angolo di entrata e uscita della catena

Un tenditore sprigiona una forza Q (Fig.17) perpendicolare al braccio di rotazione che per reazione è equilibrata dalla catena con la forza N che si ripartisce con le forze di trazione N₁ e N₂ sui rami in entrata e uscita dal tendicatena rispettivamente R₁ e R₂. Quando si posiziona un tendicatena a rotazione bisogna far attenzione che le forze Q e N siano il più possibile sulla medesima direttrice in modo che non si sviluppino delle componenti tangenziali che vadano a scaricarsi sul fulcro. Ad ogni modo, nel caso del tenditore CRESA, queste indesiderate forze tangenziali sono annullate dalla forza di compressione assiale P₃ della molla in caucciù.

Il posizionamento del tenditore, quindi, dipende dall'angolo δ, ovvero l'angolo di lavoro dell'elemento elastico, e dall'angolo ε, ovvero l'angolo di posizionamento rispetto alla trasmissione. Il progettista dovrà quindi trovare il giusto rapporto tra questi parametri in funzione della geometria della propria trasmissione.

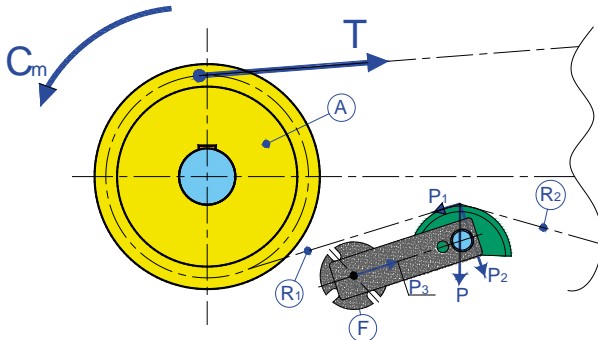

Fig.18 Distribuzione delle forze

- A = Ruota dentata motrice
- T = Tensione sul ramo teso
- C_m = Coppia motrice
- R₁ = Ramo della catena in entrata
- R₂ = Ramo della catena in uscita
- F = Fulcro o punto di rotazione
- P = Forza peso
- P₁ = Componente di P tangenziale
- P₂ = Componente di P normale
- P₃ = Forza di compressione della gomma

Fig.18 mostra l'influenza della forza peso P della catena sul tenditore in trasmissioni orizzontali. Il peso della catena, infatti, soprattutto nelle catene con un alto peso specifico per metro e con elevati interassi tra i pignoni della trasmissione, si scompone sul tendicatena con una forza P₂ normale alla leva e una forza P₁ tangenziale ad essa. Quest'ultima componente di compressione è bilanciata dalla forza assiale di compressione P₃ della gomma.

MATERIALI IMPIEGATI:

- (a) - **Corpo:** Grandezza 10-20-30-70 acciaio. 40-50-60 ghisa.
- (b) - **Leva:** Acciaio
- **Gomma:** GOBA (se non altrimenti specificato)
- **Trattamenti:** Verniciatura a forno. Viti zincate.
- **Impiego:** Temperatura di lavoro da -40°C a +80°C.

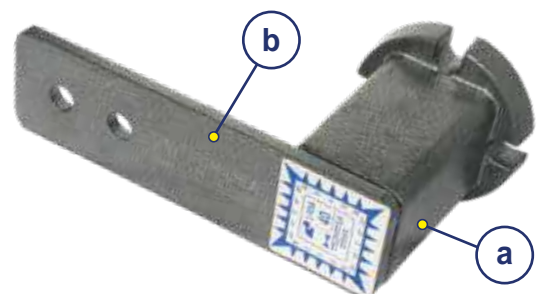

 APPLICATION EXAMPLES
 ESEMPI DI APPLICAZIONE

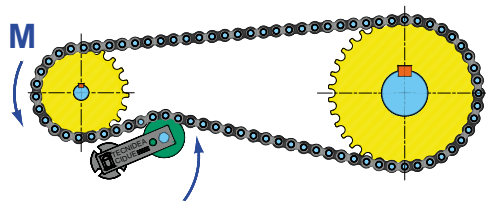



Fig.1

 CRESA elastic element allows a correct chain tensioning and the elimination of bothersome skippings.

 L'elemento elastico CRESA, permette un tensionamento "corretto" della catena; e l'eliminazione dei fastidiosi saltellamenti.

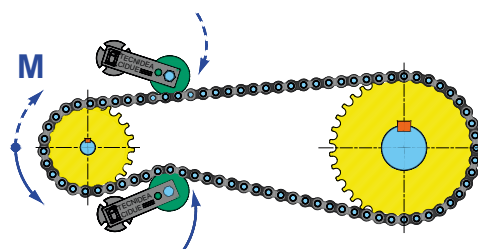



Fig.2

 For reversible transmission system, CRESA elements must be positioned on both sides. We suggest to use bigger size elements because in the tensioned section takes place a higher load, but pre-loading the tensioner with a maximum angle of 15°.

 Per sistemi di trasmissione reversibili, gli elementi CRESA devono essere posizionati su entrambi i lati. Utilizzare elementi di grandezza superiore, perché nel tratto teso si verifica un carico maggiore, caricando però il tenditore con un angolo massimo di 15°.

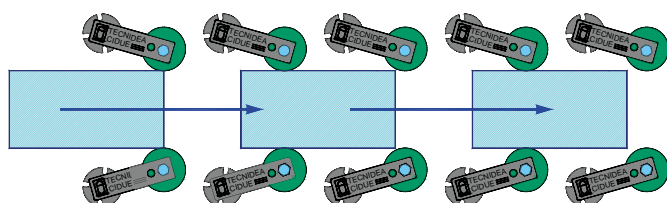



Fig.3

 Downholders or guiding elements.

 Elementi di pressione o convogliamento.

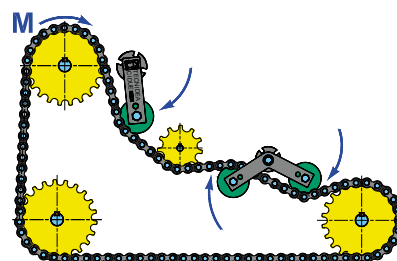



Fig.4

 For long transmission systems, we recommend the use of more tensioning elements. The tensioner suitable for this kind of application is the base-element CEB-CEBP with the DEVICE "V".

 Per trasmissioni con lunghe catene, si consiglia l'utilizzo di più elementi tenditori. Il tenditore ideale per questo tipo di applicazioni è quello con l'elemento base CEB-CEBP con il KIT "V".

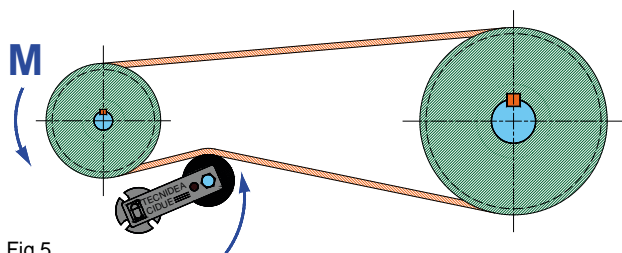



Fig.5

 The belt tensioners RP and RU must be assembled near the driving pulley. They can be positioned also inside the transmission.

 I rulli tendicinghia RP e RU devono essere montati vicino alla puleggia motrice. Possono essere posizionati anche all'interno della trasmissione.

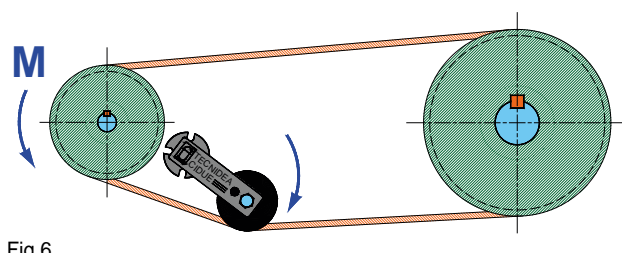



Fig.6

 Tensioners assembled with pulleys for V-type belt must be assembled inside the transmission system.

 I tenditori che montano pulegge per cinghie trapezoidali devono essere montati all'interno del sistema di trasmissione.



Fig.7

 Support for belt scraper.

 Supporto per raschianastro

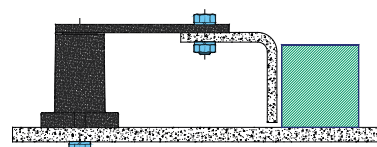

Fig.8

 Support for guide.

 Supporto per guida.

Type - *Tipo*: RER

USE Scrapers
Raschianastro

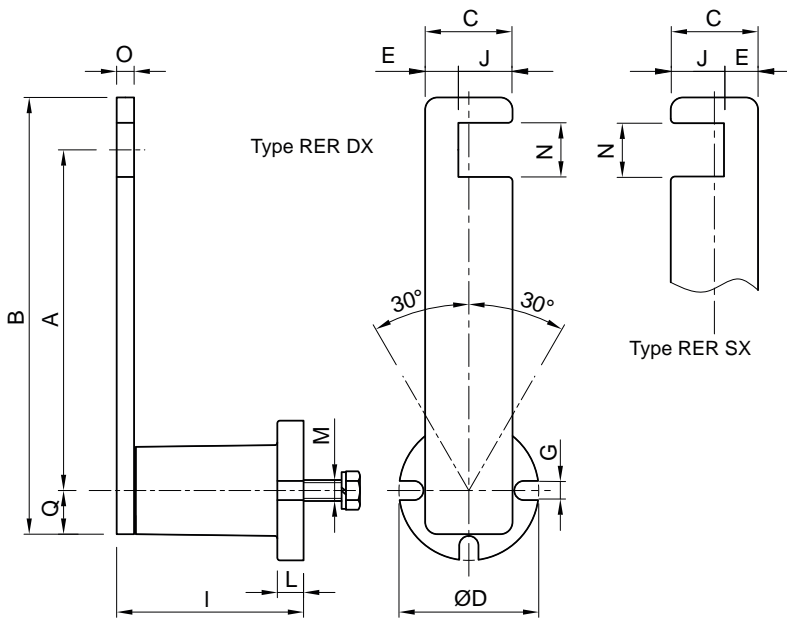

UK MATERIALS: Steel.
TREATMENTS: Oven-painted. Galvanized screw.
USE: Temperature from -40°C to + 80°C.

IT MATERIALI: Acciaio.
TRATTAMENTI: Verniciatura a forno. Vite zincata.
IMPIEGO: Temperatura da -40°C a +80°C.

Newton
0°-30°

Type <i>Tipo</i>	Cod. N°	A	B	C	ØD	E	F	G	I	J	L	M	N	O	Q	Weight Peso (kg)	Type <i>Tipo</i>	Cod. N°
RER 30 DX	RE010849	150	193,5	35	50	10	0+225	9	79,0 ^{+1,5} _{-0,5}	25	10	M10x30	30,5	8	18	1,3	RER 30 SX	RE010854
RER 40 DX	RE010850	195	250	50	80	19,5	0+525	11	107,0 ^{+1,5} _{-0,5}	30,5	15	M12x40	30,5	10	25	2,5	RER 40 SX	RE010885
RER 50 DX	RE010851	260	333	65	100	24,5	0+1075	13	142,0 ^{+2,0} _{-1,0}	40,5	15	M16x40	40,5	12	33	5,0	RER 50 SX	RE010856
RER 60 DX	RE010852	335	411,5	80	120	39,5	0+1710	13	202,0 ^{+2,5} _{-1,5}	40,5	18	M20x50	40,5	15	41,5	8,0	RER 60 SX	RE010857

F: Maximum force made by the tansioner device [N] / *Forza massima prodotta dal tenditore [N]*

SPECIAL EXECUTIONS
ESECUZIONI SPECIALI



Type - *Tipo*: **RE**

USE Tensioner device
Elemento tenditore

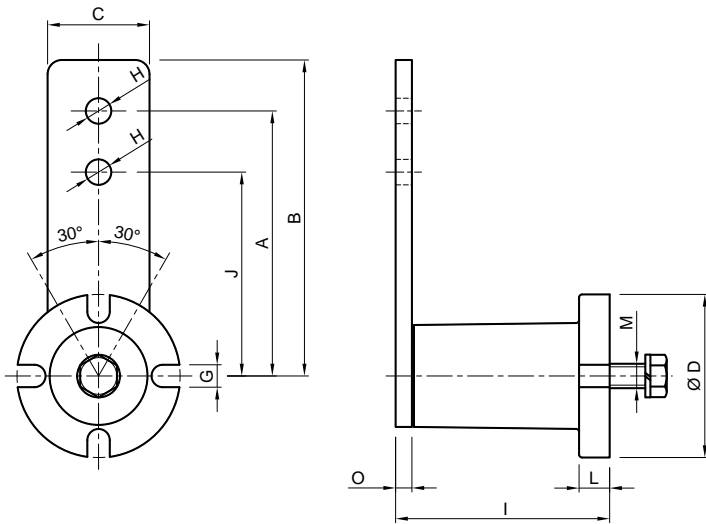

 **MATERIALS:** Steel.
TREATMENTS: Oven-painted. Galvanized screw.
USE: Temperature from -40°C to + 80°C.

 **MATERIALI:** Acciaio.
TRATTAMENTI: Verniciatura a forno. Vite zincata.
IMPIEGO: Temperatura da -40°C a +80°C.



Type Tipo	Cod. N°	A	B	C	ØD	G	ØH	I	J	L	M	O	P	T	U	Newton 0°-30° Arm Braccio (A)	Newton 0°-30° Arm Braccio (J)	Weight Peso (kg)	Type Tipo	Cod. N°
RE 10	RE010010	80	90	25	40	7	8,5	50,5 ^{+1,5} _{-0,5}	60	6	M6x20	5	M4	25	15,5	0÷90	0÷120	0,28	REP 10	RE010080
RE 20	RE010020	100	112	30	50	9	10,5	62,5 ^{+1,5} _{-0,5}	80	8	M8x25	5	M6	35	20,5	0÷140	0÷175	0,48	REP 20	RE010090
RE 30	RE010030	100	115	35	60	9	10,5	77,0 ^{+1,5} _{-0,5}	80	10	M10x30	6	M6	40	23,5	0÷380	0÷475	0,73	REP 30	RE010100
RE 40	RE010040	130	155	50	80	11	12,5	106,0 ^{+2,0} _{-1,0}	100	15	M12x40	8	M8	60	31,5	0÷860	0÷1118	2,00	REP 40	RE010110
RE 50	RE010050	175	205	65	100	13	20,5	140,0 ^{+2,0} _{-1,0}	140	15	M16x40	10	M8	80	41,5	0÷1600	0÷2000	4,20	REP 50	RE010120
RE 60	RE010060	225	260	80	120	13	20,5	199,0 ^{+2,5} _{-1,5}	180	18	M20x50	12	M10	115	50,0	0÷2700	0÷3375	7,00	REP 60	RE010130
RE 70	RE010070	250	290	90	130	Ø17*	20,5	209,0 ^{+2,5} _{-1,5}	200	20	M24x60	20	M12	115	53,5	0÷4400	0÷5500	9,60	REP 70	RE010140

* Execution with holes Ø17 mm / *Esecuzione con fori Ø17 mm*



Type - *Tipo*: **REP**

USE With preloading
Con precarica

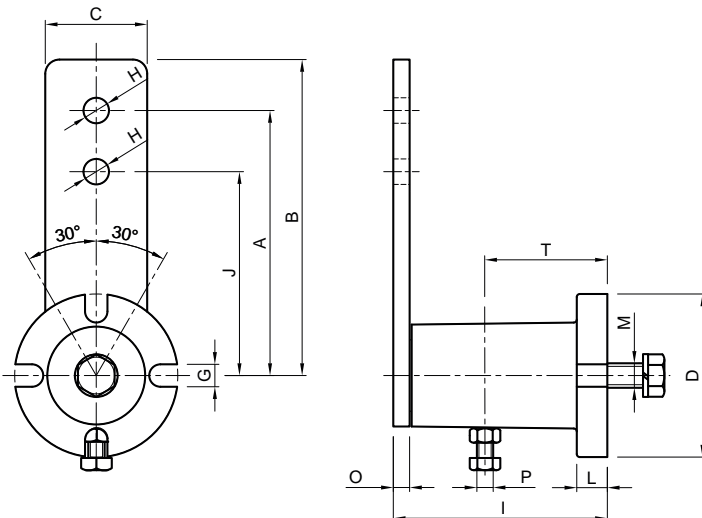

 **MATERIALS:** Steel.
TREATMENTS: Oven-painted. Galvanized screw.
USE: Temperature from -40°C to + 80°C.

 **MATERIALI:** Acciaio.
TRATTAMENTI: Verniciatura a forno. Vite zincata.
IMPIEGO: Temperatura da -40°C a +80°C.

Type - Tipo: RES

USE For high temperature
Per alte temperature

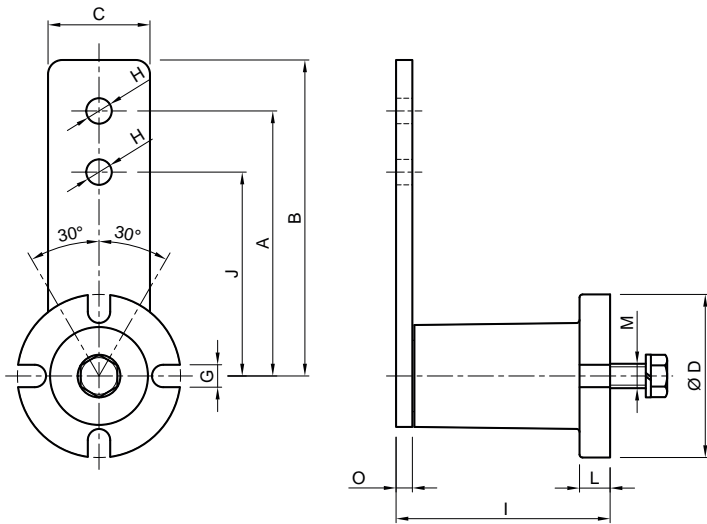

MATERIALS Steel. Rubber: GOSIL-Silicone
TREATMENTS Oven-painted. Galvanized screws.
USE Temperature from -35°C to +130°C, highlighted in red label.

MATERIALI Acciaio. Gomma: GOSIL-Siliconica
TRATTAMENTI Verniciatura a forno. Viti zincate.
IMPIEGO Temperatura da -35°C a +130°C, sono evidenziati con un'etichetta rossa.



Type Tipo	Cod. N°	A	B	C	ØD	G	ØH	I	J	L	M	O	P	T	Newton 0°-30° Arm Braccio (A)	Newton 0°-30° Arm Braccio (J)	Weight Peso (kg)	Type Tipo	Cod. N°
RES 20	RE010021	100	112	30	50	9	10,5	62,5 ^{+1,5} _{-0,5}	80	8	M8x25	5	M6	35	0÷84	0÷105	0,48	RESP 20	RE010091
RES 30	RE010031	100	115	35	60	9	10,5	77,0 ^{+1,5} _{-0,5}	80	10	M10x30	6	M6	40	0÷228	0÷285	0,73	RESP 30	RE010101
RES 40	RE010041	130	155	50	80	11	12,5	106,0 ^{+2,0} _{-1,0}	100	15	M12x40	8	M8	60	0÷516	0÷670	2,00	RESP 40	RE010111
RES 50	RE010051	175	205	65	100	13	20,5	140,0 ^{+2,0} _{-1,0}	140	15	M16x40	10	M8	80	0÷960	0÷1200	4,20	RESP 50	RE010121
RES 60	RE010061	225	260	80	120	13	20,5	199,0 ^{+2,5} _{-1,5}	180	18	M20x50	12	M10	115	0÷1620	0÷2025	7,00	RESP 60	RE010131
RES 70	RE010071	250	290	90	130	Ø17*	20,5	209,0 ^{+2,5} _{-1,5}	200	20	M24x60	20	M12	115	0÷2640	0÷3300	9,60	RESP 70	RE010141

* Execution with holes Ø17 mm / Esecuzione con fori Ø17 mm

Type - Tipo: RESP

USE For high temperature - With preloading
Per alte temperature - Con precarica

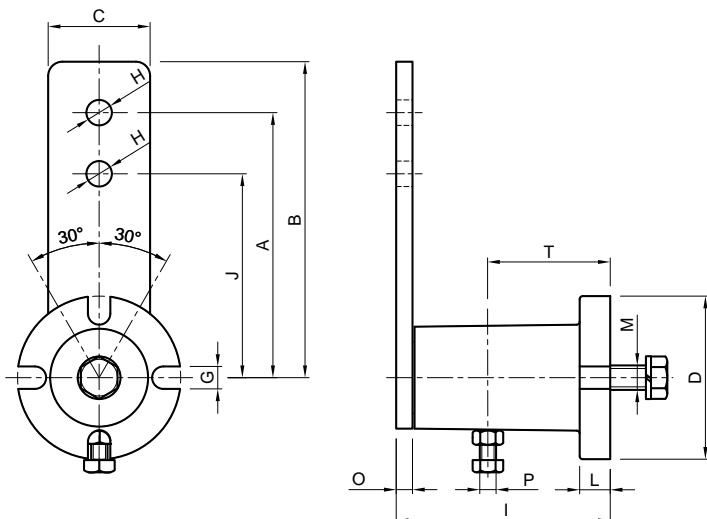

MATERIALS Steel. Rubber: GOSIL-Silicone
TREATMENTS Oven-painted. Galvanized screws.
USE Temperature from -35°C to +130°C, highlighted in red label.

MATERIALI Acciaio. Gomma: GOSIL-Siliconica
TRATTAMENTI Verniciatura a forno. Viti zincate.
IMPIEGO Temperatura da -35°C a +130°C, sono evidenziati con un'etichetta rossa.



Type - *Tipo*: FE

USE Front mounting
Montaggio frontale

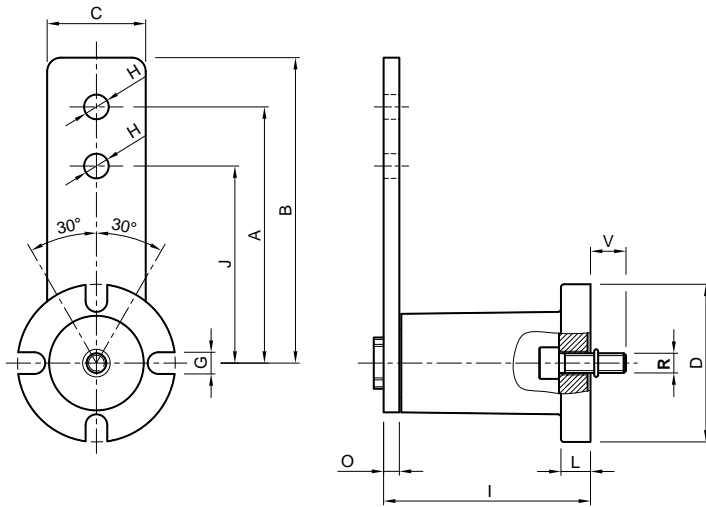

 **MATERIALS:** Steel.
TREATMENTS: Oven-painted. Galvanized screw.
USE: Temperature from -40°C to + 80°C.

 **MATERIALI:** Acciaio.
TRATTAMENTI: Verniciatura a forno. Vite zincata.
IMPIEGO: Temperatura da -40°C a +80°C.



Type <i>Tipo</i>	Cod. N°	A	B	C	ØD	G	ØH	I	J	L	O	P	R	T	U	V	Newton 0°-30° Arm Braccio (A)	Newton 0°-30° Arm Braccio (J)	Weight Peso (kg)	Type <i>Tipo</i>	Cod. N°
FE 10	RE010150	80	90	25	40	7	8,5	50,5 ^{+1,5} _{-0,5}	60	6	5	M4	M5	25	15,5	10	0+90	0+120	0,25	FEP 10	RE010220
FE 20	RE010160	100	112	30	50	9	10,5	62,5 ^{+1,5} _{-0,5}	80	8	5	M6	M6	35	20,5	14	0+140	0+175	0,45	FEP 20	RE010230
FE 30	RE010170	100	115	35	60	9	10,5	77,0 ^{+1,5} _{-0,5}	80	10	6	M6	M8	40	23,5	19	0+380	0+475	0,69	FEP 30	RE010240
FE 40	RE010180	130	155	50	80	11	12,5	106,0 ^{+2,0} _{-1,0}	100	15	8	M8	M10	60	31,5	18	0+860	0+1118	1,90	FEP 40	RE010250
FE 50	RE010190	175	205	65	100	13	20,5	140,0 ^{+2,0} _{-1,0}	140	15	10	M8	M12	80	41,5	20	0+1600	0+2000	3,90	FEP 50	RE010260
FE 60	RE010200	225	260	80	120	13	20,5	199,0 ^{+2,5} _{-1,5}	180	18	12	M10	M16	115	50,0	36	0+2700	0+3375	6,90	FEP 60	RE010270
FE 70	RE010210	250	290	90	130	Ø17*	20,5	209,0 ^{+2,5} _{-1,5}	200	20	20	M12	M20	115	53,5	25	0+4400	0+5500	9,50	FEP 70	RE010280

* Execution with holes Ø17 mm / *Esecuzione con fori Ø17 mm*



Type - *Tipo*: FEP

USE Front mounting - With preloading
Montaggio frontale - Con precarica

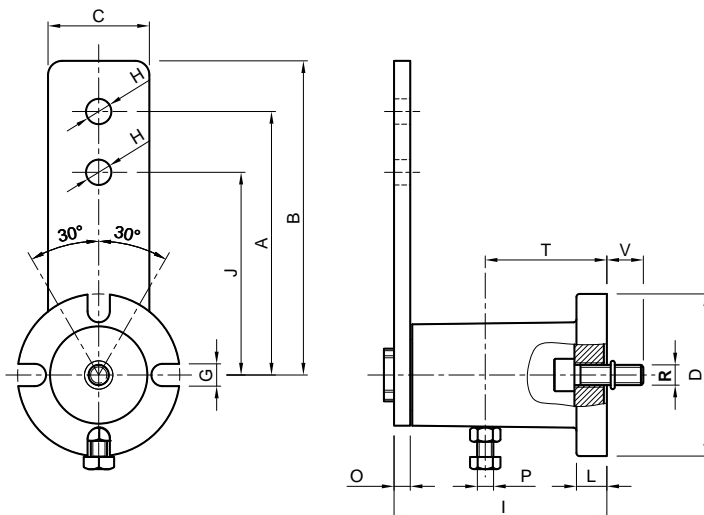

 **MATERIALS:** Steel.
TREATMENTS: Oven-painted. Galvanized screw.
USE: Temperature from -40°C to + 80°C.

 **MATERIALI:** Acciaio.
TRATTAMENTI: Verniciatura a forno. Vite zincata.
IMPIEGO: Temperatura da -40°C a +80°C.

Type - *Tipo*: **BE**

USE Radial regulation of 360°
Regolazione radiale di 360°

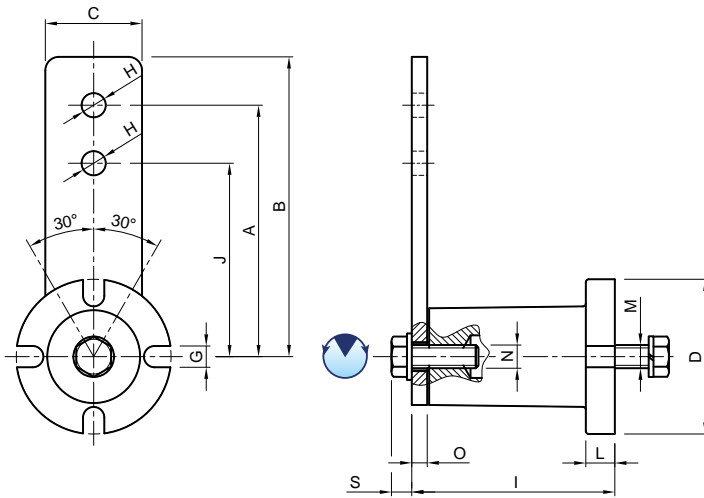

MATERIALS: Steel.
TREATMENTS: Oven-painted. Galvanized screw.
USE: Temperature from -40°C to + 80°C.

MATERIALI: Acciaio.
TRATTAMENTI: Verniciatura a forno. Vite zincata.
IMPIEGO: Temperatura da -40°C a +80°C.



Type <i>Tipo</i>	Cod. N°	A	B	C	ØD	G	ØH	I	J	L	M	N	O	P	S	T	Newton	Newton	Weight Peso (kg)	Type <i>Tipo</i>	Cod. N°
																	0°-30°	0°-30°			
BE 10	RE010290	80	90	25	40	7	8,5	50 ^{+1,5} _{-0,5}	60	6	M6x20	M 8	5	M 4	8	25	0÷90	0÷120	0,28	BEP 10	RE010360
BE 20	RE010300	100	112	30	50	9	10,5	62 ^{+1,5} _{-0,5}	80	8	M8x25	M10	5	M 6	9	35	0÷140	0÷175	0,48	BEP 20	RE010370
BE 30	RE010310	100	115	35	60	9	10,5	76 ^{+1,5} _{-0,5}	80	10	M10x30	M10	6	M 6	9	40	0÷380	0÷475	0,73	BEP 30	RE010380
BE 40	RE010320	130	155	50	80	11	12,5	105 ^{+2,0} _{-1,0}	100	15	M12x40	M12	8	M 8	11	60	0÷860	0÷1118	2,00	BEP 40	RE010390
BE 50	RE010330	175	205	65	100	13	20,5	136 ^{+2,0} _{-1,0}	140	15	M16x40	M20	10	M 8	17	80	0÷1600	0÷2000	4,20	BEP 50	RE010400
BE 60	RE010340	225	260	80	120	13	20,5	196 ^{+2,5} _{-1,5}	180	18	M20x50	M20	12	M10	17	115	0÷3375	0÷3375	7,00	BEP 60	RE010410
BE 70	RE010350	250	290	90	130	Ø17*	20,5	210 ^{+2,5} _{-1,5}	200	20	M24x60	M24	20	M12	20	115	0÷4400	0÷5500	9,60	BEP 70	RE010420

* Execution with holes Ø17 mm / *Esecuzione con fori Ø17 mm*



Type - *Tipo*: **BEP**

USE Radial regulation of 360° - With preloading
Regolazione radiale di 360° - Con precarica

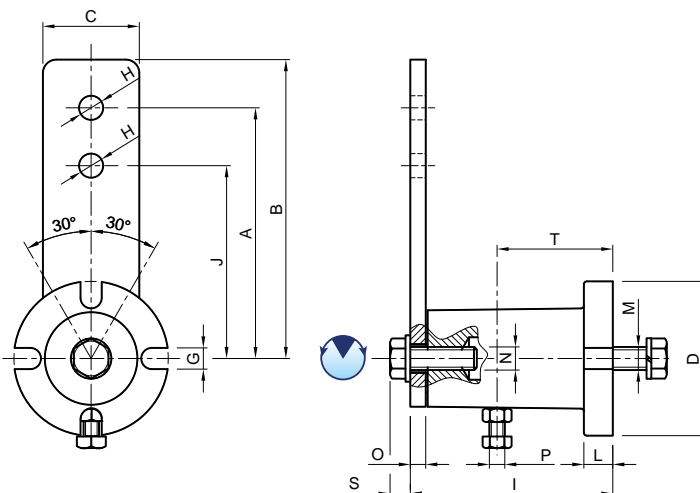

MATERIALS: Steel.
TREATMENTS: Oven-painted. Galvanized screw.
USE: Temperature from -40°C to + 80°C.

MATERIALI: Acciaio.
TRATTAMENTI: Verniciatura a forno. Vite zincata.
IMPIEGO: Temperatura da -40°C a +80°C.

Type - Tipo: **ME**

USE Variable loading
Carico variabile

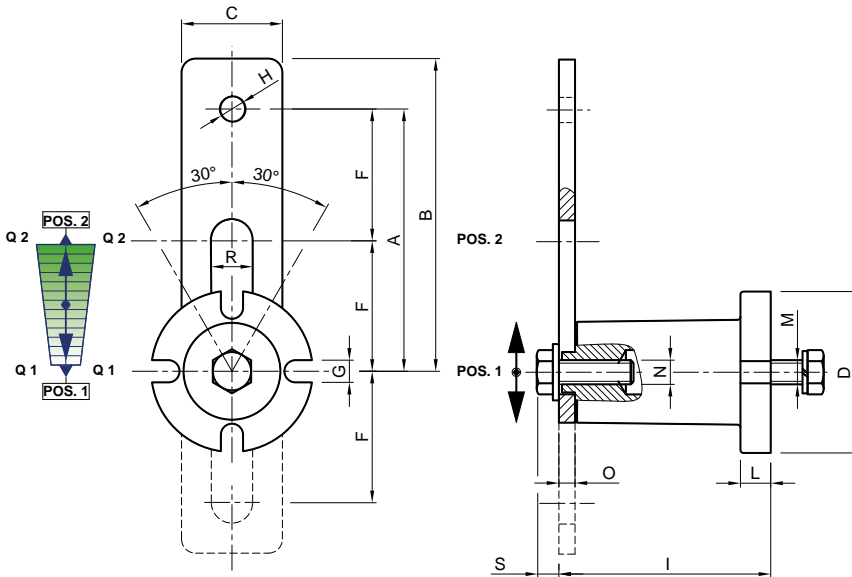

UK MATERIALS: Steel.
TREATMENTS: Oven-painted. Galvanized screw.
USE: Temperature from -40°C to + 80°C.

IT MATERIALI: Acciaio.
TRATTAMENTI: Verniciatura a forno. Vite zincata.
IMPIEGO: Temperatura da -40°C a +80°C.



Type Tipo	Cod. N°	A	B	C	ØD	F	G	ØH	I	L	M	N	O	P	R	S	T	Pos.1 Q 1	Pos.2 Q 2	Weight Peso (kg)	Type Tipo	Cod. N°
ME 10	RE010430	80	90	25	40	40,0	7	8,5	51 ^{+1,5} _{-0,5}	6	M6x20	M6	6	M4	10,0	7	25	0+90	0+120	0,28	MEP 10	RE010500
ME 20	RE010440	100	112	30	50	50,0	9	10,5	63 ^{+1,5} _{-0,5}	8	M8x25	M8	6	M6	12,0	10	35	0+140	0+175	0,48	MEP 20	RE010510
ME 30	RE010450	100	115	35	60	50,0	9	10,5	78 ^{+1,5} _{-0,5}	10	M10x30	M10	8	M6	14,5	12	40	0+380	0+475	0,73	MEP 30	RE010520
ME 40	RE010460	130	155	50	80	50,0	11	12,5	107 ^{+2,0} _{-1,0}	15	M12x40	M12	10	M8	20,5	13	60	0+860	0+1118	2,00	MEP 40	RE010530
ME 50	RE010470	175	205	65	100	65,0	13	20,5	138 ^{+2,0} _{-1,0}	15	M16x40	M16	12	M8	27,0	17	80	0+1600	0+2000	4,20	MEP 50	RE010540
ME 60	RE010480	225	260	80	120	87,5	13	20,5	199 ^{+2,5} _{-1,5}	18	M20x50	M20	15	M10	35,0	21	115	0+2700	0+3375	7,00	MEP 60	RE010550
ME 70	RE010490	250	290	90	130	110,0	Ø17*	20,5	212 ^{+2,5} _{-1,5}	20	M24x60	M24	20	M12	42,0	24	115	0+4400	0+5500	10,00	MEP 70	RE010560

* Execution with holes Ø17 mm / Esecuzione con fori Ø17 mm



Type - Tipo: **MEP**

USE Variable loading - With preloading
Carico variabile - Con precarica

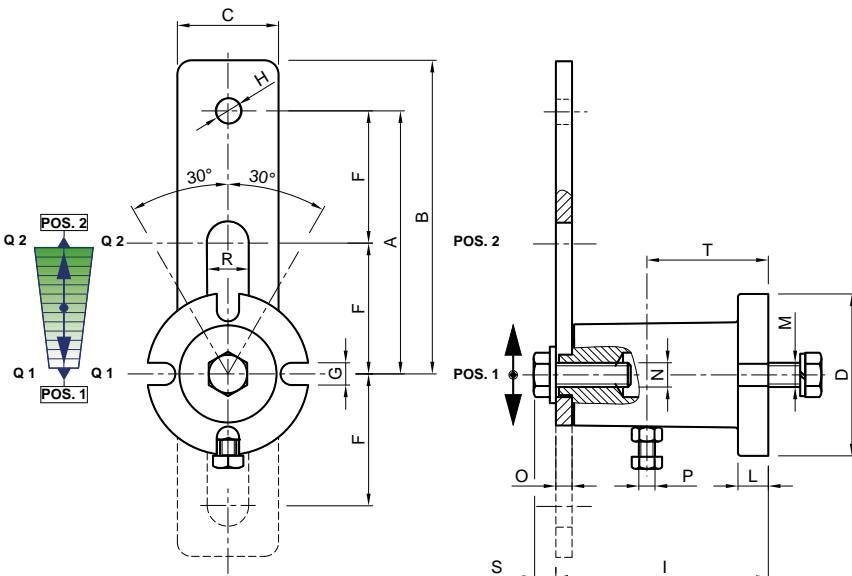

UK MATERIALS: Steel.
TREATMENTS: Oven-painted. Galvanized screw.
USE: Temperature from -40°C to + 80°C.

IT MATERIALI: Acciaio.
TRATTAMENTI: Verniciatura a forno. Vite zincata.
IMPIEGO: Temperatura da -40°C a +80°C.

Type - Tipo: REX

USE Anticorrosive
Anticorrosione



INOX

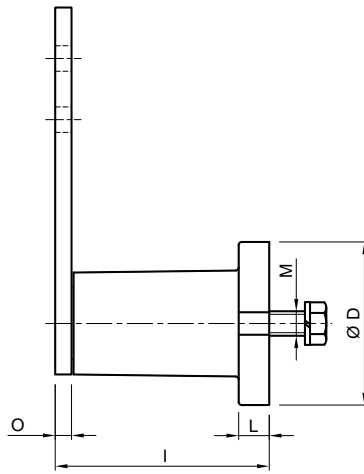
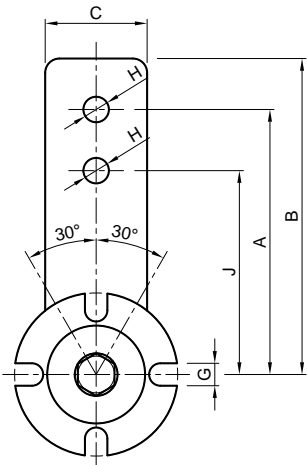

UK MATERIALS Stainless steel.
TREATMENTS Finishing and anti-corrosion treatments.
USE Temperature from -40°C to +80°C. High resistance to corrosive attacks.

IT MATERIALI Acciaio inossidabile.
TRATTAMENTI Specifici di finitura ed anticorrosivi.
IMPIEGO Temperatura da -40°C a +80°C.
Ottima capacità di resistere agli attacchi corrosivi.

Type Tipo	Cod. N°	A	B	C	ØD	G	ØH	I	J	L	M	O	Newton 0°-30° Arm Braccio (A)	Newton 0°-30° Arm Braccio (J)	Weight Peso (kg)
REX 20	RE010024	100	112	30	50	9	10,5	62,5 ^{+1,5} _{-0,5}	80	8	M8x25	5	0÷140	0÷175	0,48
REX 30	RE010034	100	115	35	60	8,5	10,5	77,0 ^{+1,5} _{-0,5}	80	10	M10x30	6	0÷380	0÷475	0,73
REX 40	RE010044	130	155	50	78	10,5	12,5	106,0 ^{+2,0} _{-1,0}	100	12	M12x40	8	0÷860	0÷1118	2,00
REX 50	RE010054	175	205	60	95	12,5	20,5	140,0 ^{+2,0} _{-1,0}	140	15	M16x40	10	0÷1600	0÷2000	4,20

Type - Tipo: REG - REZ

USE Anticorrosive
Anticorrosione



ANOX®

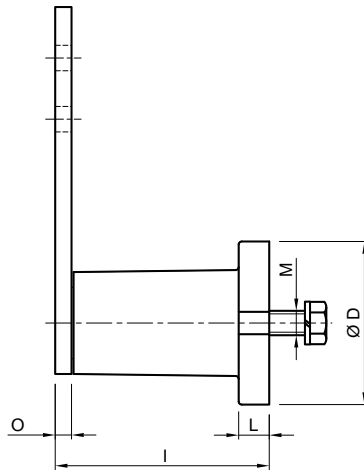
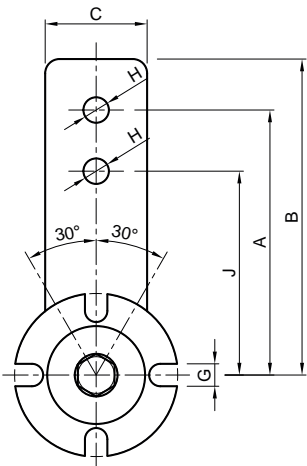

Mod. REG
Nickel-plated
Nichelato



Mod. REZ
Galvanized
Zincato



UK MATERIALS Steel.
TREATMENTS REG nickel-plated - REZ galvanized. Screws galvanized.
USE Temperature from -40°C to +80°C. Resistance to oxidation.

IT MATERIALI Acciaio.
TRATTAMENTI REG nichelato - REZ zincato. Viti zincate.
IMPIEGO Temperatura da -40°C a +80°C.
Resistenza alla ossidazione.

Type Tipo	Cod. N°	Type Tipo	Cod. N°	A	B	C	ØD	G	ØH	I	J	L	M	O	Newton 0°-30° Arm Braccio (A)	Newton 0°-30° Arm Braccio (J)	Weight Peso (kg)
REG 10	RE010012	REZ 10	RE010015	80	90	25	40	7	8,5	50,5 ^{+1,5} _{-0,5}	60	6	M6x20	5	0÷90	0÷120	0,28
REG 20	RE010022	REZ 20	RE010025	100	112	30	50	9	10,5	62,5 ^{+1,5} _{-0,5}	80	8	M8x25	5	0÷140	0÷175	0,48
REG 30	RE010032	REZ 30	RE010035	100	115	35	60	9	10,5	77,0 ^{+1,5} _{-0,5}	80	10	M10x30	6	0÷380	0÷475	0,73
REG 40	RE010042	REZ 40	RE010045	130	155	50	80	11	12,5	106,0 ^{+2,0} _{-1,0}	100	15	M12x40	8	0÷860	0÷1118	2,00
REG 50	RE010052	REZ 50	RE010055	175	205	65	100	13	20,5	140,0 ^{+2,0} _{-1,0}	140	15	M16x40	10	0÷1600	0÷2000	4,20
REG 60	RE010062	REZ 60	RE010065	225	260	80	120	13	20,5	199,0 ^{+2,5} _{-1,5}	180	18	M20x50	12	0÷2700	0÷3375	7,00
REG 70	RE010072	REZ 70	RE010075	250	290	90	130	Ø17	20,5	209,0 ^{+2,5} _{-1,5}	200	20	M24x60	20	0÷4400	0÷5500	9,60

Type - *Tipo*: **CEA - CEAP**

USE Flat base
Base piano

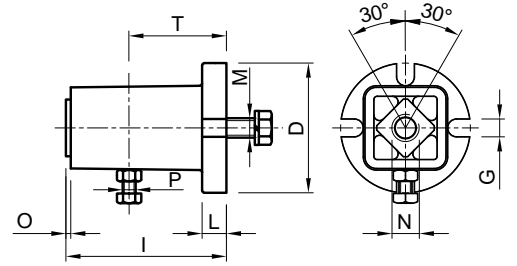
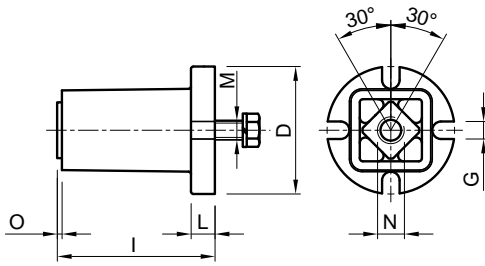

 **MATERIALS** Steel.
TREATMENTS The body is oven-painted. Pin and screws are galvanized.
USE Temperature from -40°C to +80°C.

 **MATERIALI** Acciaio.
TRATTAMENTI Corpo verniciato a forno, perno e viti zincate.
IMPIEGO Temperatura da -40°C a +80°C.

Type <i>Tipo</i>	Cod. N°	ØD	G	I	L	M	N	O	P	T	Torque Q Carico Q (Nm) 0°-30°	Weight Peso (kg)	Type <i>Tipo</i>	Cod. N°
CEA 10	RE010570	40	7	45 ^{+1,5} _{-0,5}	6	M6	M8	1	M4	25	0÷7,2	0,19	CEAP 10	RE010640
CEA 20	RE010580	50	9	57 ^{+1,5} _{-0,5}	8	M8	M10	1	M6	35	0÷14,0	0,34	CEAP 20	RE010650
CEA 30	RE010590	60	9	70 ^{+1,5} _{-0,5}	10	M10	M10	1	M6	40	0÷38,0	0,52	CEAP 30	RE010660
CEA 40	RE010600	80	11	97 ^{+2,0} _{-1,0}	15	M12	M12	1	M8	60	0÷111,8	1,50	CEAP 40	RE010670
CEA 50	RE010610	100	13	126 ^{+2,0} _{-1,0}	15	M16	M20	1	M8	80	0÷280,0	3,10	CEAP 50	RE010680
CEA 60	RE010620	120	13	184 ^{+2,5} _{-1,5}	18	M20	M20	2	M10	115	0÷607,5	4,90	CEAP 60	RE010690
CEA 70	RE010630	130	Ø17	182 ^{+2,5} _{-1,5}	20	M24	M24	2	M12	115	0÷1100,0	6,00	CEAP 70	RE010700

Q: Torque [Nm] / Carico di Torsione [Nm]

Type - *Tipo*: **CEB - CEBP**

USE Bayonet base
Base a baionetta

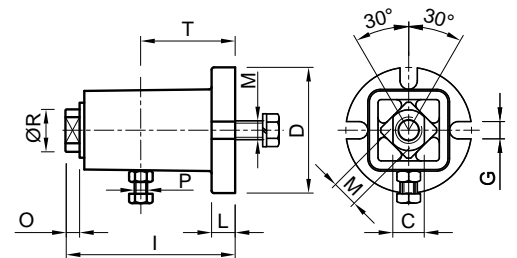
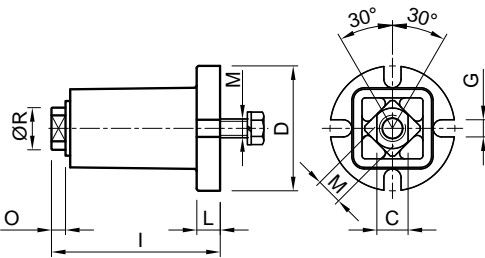

 **MATERIALS** Steel.
TREATMENTS The body is oven-painted. Pin and screws are galvanized.
USE Temperature from -40°C to +80°C.

 **MATERIALI** Acciaio.
TRATTAMENTI Corpo verniciato a forno, perno e viti zincate.
IMPIEGO Temperatura da -40°C a +80°C.

Type <i>Tipo</i>	Cod. N°	C	ØD	G	I	L	M	O	P	ØR	T	Torque Q Carico Q (Nm) 0°-30°	Weight Peso (kg)	Type <i>Tipo</i>	Cod. N°
CEB 10	RE010710	9,5	40	7	50 ^{+1,5} _{-0,5}	6	M6	5	M4	11	25	0÷7,2	0,19	CEBP 10	RE010780
CEB 20	RE010720	11,5	50	9	62 ^{+1,5} _{-0,5}	8	M8	5	M6	15	35	0÷14,0	0,34	CEBP 20	RE010790
CEB 30	RE010730	14,5	60	9	77 ^{+1,5} _{-0,5}	10	M10	7	M6	18	40	0÷38,0	0,52	CEBP 30	RE010800
CEB 40	RE010740	20,0	80	11	106 ^{+2,0} _{-1,0}	15	M12	9	M8	27	60	0÷111,8	1,50	CEBP 40	RE010810
CEB 50	RE010750	26,0	100	13	137 ^{+2,0} _{-1,0}	15	M16	11	M8	38	80	0÷280,0	3,10	CEBP 50	RE010820
CEB 60	RE010760	34,0	120	13	198 ^{+2,5} _{-1,5}	18	M20	14	M10	45	115	0÷607,5	4,90	CEBP 60	RE010830
CEB 70	RE010770	40,0	130	Ø17	201 ^{+2,5} _{-1,5}	20	M24	19	M12	50	115	0÷1100,0	6,00	CEBP 70	RE010840

Q: Torque [Nm] / Carico di Torsione [Nm]

Type - Tipo: CET - CETP

USE Tube base
Base a tubo

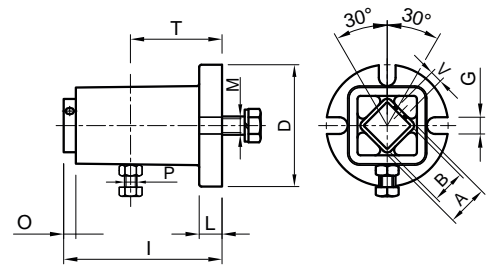
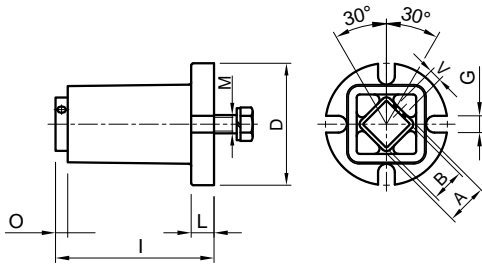

MATERIALS Steel.
TREATMENTS The body is oven-painted. Pin and screws are galvanized.
USE Temperature from -40°C to +80°C.

MATERIALI Acciaio.
TRATTAMENTI Corpo verniciato a forno, perno e viti zincate.
IMPIEGO Temperatura da -40°C a +80°C.



Type Tipo	Cod.N°	A	B	ØD	G	I	L	M	O	P	T	V	Torque Q Carico Q (Nm) 0°-30°	Weight Peso (kg)	Type Tipo	Cod.N°
CET 10	RE010711	11	8 ^{+0,25} _{+0,00}	40	7	50 ^{+1,5} _{-0,5}	6	M6	6	M4	25	M6	0÷7,2	0,16	CETP 10	RE010781
CET 20	RE010721	15	11 ^{+0,25} _{+0,00}	50	9	64 ^{+1,5} _{-0,5}	8	M8	8	M6	35	M6	0÷14,0	0,30	CETP 20	RE010791
CET 30	RE010731	18	12 ^{+0,25} _{+0,00}	60	9	77 ^{+1,5} _{-0,5}	10	M10	8	M6	40	M6	0÷38,0	0,46	CETP 30	RE010801
CET 40	RE010741	27	22 ^{+0,25} _{+0,00}	80	11	106 ^{+2,0} _{-1,0}	15	M12	10	M8	60	M8	0÷111,8	1,40	CETP 40	RE010811
CET 50	RE010751	40	30 ^{+0,25} _{+0,00}	100	13	135 ^{+2,0} _{-1,0}	15	M16	10	M8	80	M8	0÷280,0	2,50	CETP 50	RE010821
CET 60	RE010761	45	35 ^{+0,40} _{+0,00}	120	13	196 ^{+2,5} _{-1,5}	18	M20	14	M10	115	M10	0÷607,5	4,30	CETP 60	RE010831
CET 70	RE010771	50	40 ^{+0,40} _{+0,00}	130	Ø17	195 ^{+2,5} _{-1,5}	20	M24	15	M12	115	M10	0÷1100,0	5,50	CETP 70	RE010841

Q: Torque [Nm] / Carico di Torsione [Nm]

Type - Tipo: CEP - CEPP

USE Base with threaded holes
Base con fori filettati

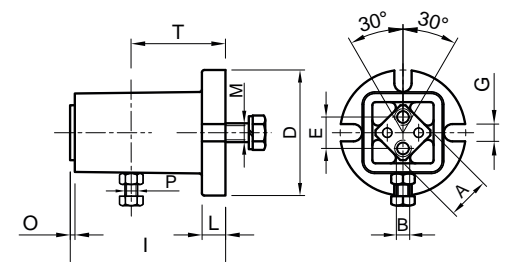
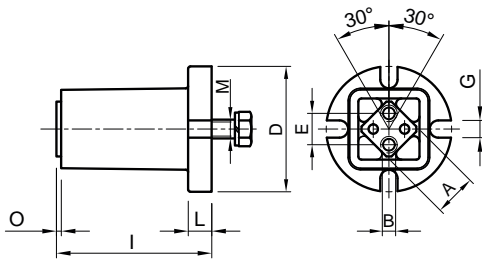

MATERIALS Steel.
TREATMENTS The body is oven-painted. Pin and screws are galvanized.
USE Temperature from -40°C to +80°C.

MATERIALI Acciaio.
TRATTAMENTI Corpo verniciato a forno, perno e viti zincate.
IMPIEGO Temperatura da -40°C a +80°C.



Type Tipo	Cod.N°	A	B	ØD	E	G	I	L	M	O	P	T	Torque Q Carico Q (Nm) 0°-30°	Weight Peso (kg)	Type Tipo	Cod.N°
CEP 20	RE010722	15	M6x15	50	10	9	57 ^{+1,5} _{-0,5}	8	M8	1	M6	35	0÷14,0	0,30	CEPP 20	RE010792
CEP 30	RE010732	18	M6x15	60	12	9	70 ^{+1,5} _{-0,5}	10	M10	1	M6	40	0÷38,0	0,46	CEPP 30	RE010802
CEP 40	RE010742	27	M10x30	80	20	11	97 ^{+2,0} _{-1,0}	15	M12	1	M8	60	0÷111,8	1,40	CEPP 40	RE010812
CEP 50	RE010752	40	M12x30	100	25	13	126 ^{+2,0} _{-1,0}	15	M16	1	M8	80	0÷280,0	2,50	CEPP 50	RE010822
CEP 60	RE010762	45	M14x35	120	35	13	184 ^{+2,5} _{-1,5}	18	M20	2	M10	115	0÷607,5	4,30	CEPP 60	RE010832
CEP 70	RE010772	50	M12x40	130	40	Ø17	182 ^{+2,5} _{-1,5}	20	M24	2	M12	115	0÷1100,0	5,50	CEPP 70	RE010842

Q: Torque [Nm] / Carico di Torsione [Nm]

Type - *Tipo*: FM

USE Electric travel-end switch
Fine corsa elettrico

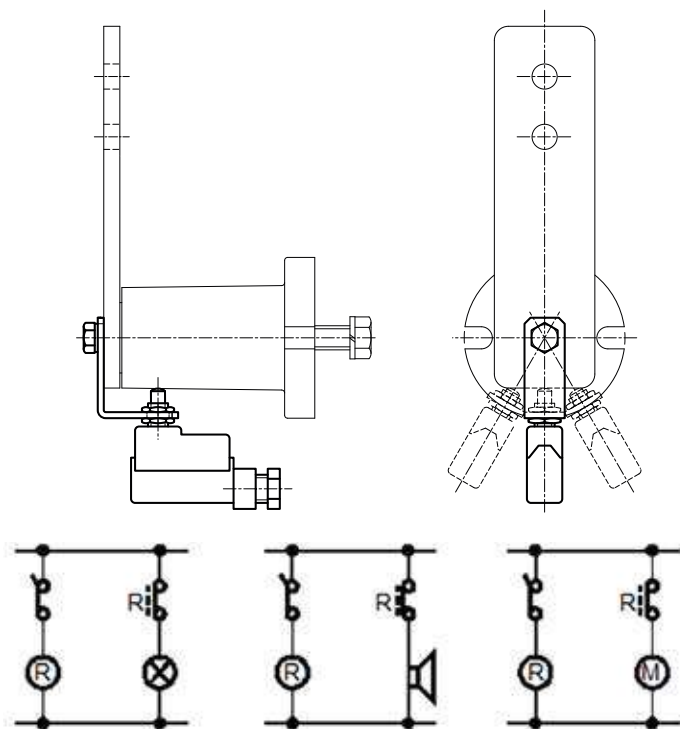

Electrical diagram / *Schema elettrico*



Type <i>Tipo</i>	Cod. N°
FM 10	RE011065
FM 20	RE011066
FM 30	RE011067
FM 40	RE011068
FM 50	RE011069
FM 60	RE011070
FM 70	RE011071

 The electric travel-end switch are particularly useful when you have to control the correct operation of the machine and/or ensure operator safety. See wiring diagram.

 *I fine corsa elettrici a interruttore sono particolarmente utili quando si voglia controllare il corretto funzionamento della macchina e/o salvaguardare l'incolumità degli operatori. Vedi schema elettrico.*

Type - *Tipo*: FPI

USE Inductive travel-end switch
Fine corsa di prossimità induttivo

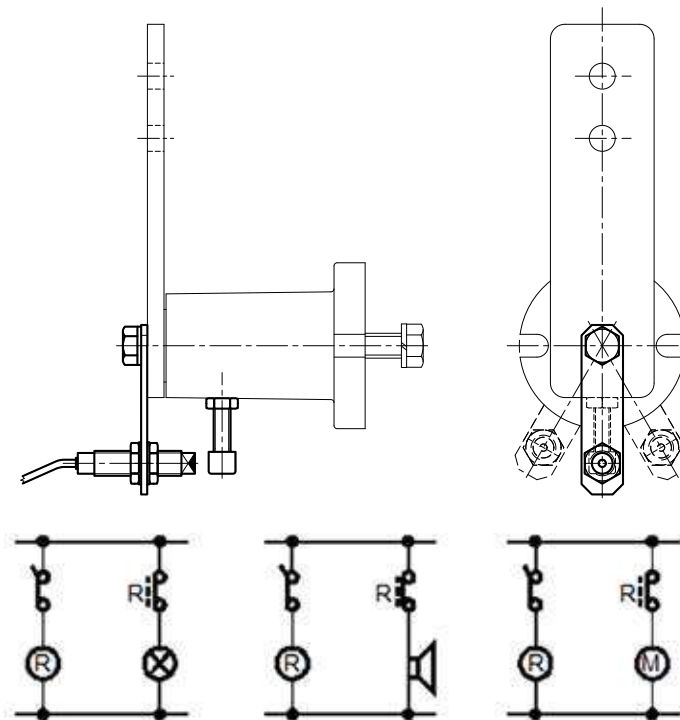

Electrical diagram / *Schema elettrico*



Type <i>Tipo</i>	Cod. N°
FPI 10	RE011075
FPI 20	RE011076
FPI 30	RE011077
FPI 40	RE011078
FPI 50	RE011079
FPI 60	RE011080
FPI 70	RE011081

 The electric travel-end switch are particularly useful when you have to control the correct operation of the machine and/or ensure operator safety. See wiring diagram.

 *I fine corsa elettrici a interruttore sono particolarmente utili quando si voglia controllare il corretto funzionamento della macchina e/o salvaguardare l'incolumità degli operatori. Vedi schema elettrico.*

Type - Tipo: SU and ST

USE Bracket
Supporto



Mod. SU

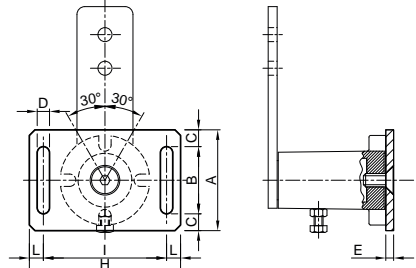

MATERIALS Steel.

TREATMENTS Galvanised.

USE The elastic element can be adjusted in two ways: radially and axially by means of the "SU" and "ST" brackets.



MATERIALI Acciaio.

TRATTAMENTI Zincatura.

IMPIEGO Con le staffe "SU" e "ST" è possibile avere la doppia regolazione dell'elemento elastico radiale ed assiale.

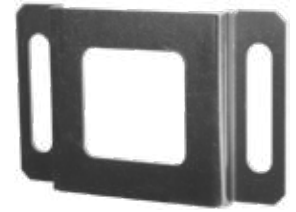

Mod. ST

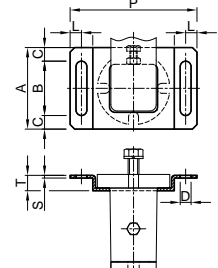

Type Tipo	Cod. N°	Weight Peso (kg)	A	B	C	D	E	H	I	L	N	O	P	S	T	Weight Peso (kg)	Type Tipo	Cod. N°
SU 10	RE011010	0,07	40	30	5,0	7	4	75	60	7,5	65	7,5	80	2	7,4	0,03	ST 10	RE011020
SU 20	RE011011	0,18	55	35	10,0	9	5	95	75	10,0	80	10,0	100	2	9,0	0,07	ST 20	RE011021
SU 30	RE011012	0,27	65	40	12,5	9	6	105	85	10,0	95	10,0	115	2	11,5	0,13	ST 30	RE011022
SU 40	RE011013	0,60	90	60	15,0	11	8	135	110	12,5	115	12,5	140	3	17,0	0,27	ST 40	RE011023
SU 50	RE011014	0,90	110	70	20,0	13	8	160	135	12,5	145	12,5	170	4	18,0	0,39	ST 50	RE011024
SU 60	RE011015	1,70	130	90	20,0	17	10	190	160	15,0	180	15,0	210	5	22,0	0,75	ST 60	RE011025

Type - Tipo: SB

USE Bracket
Supporto

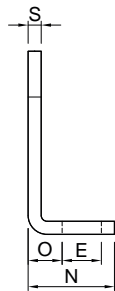
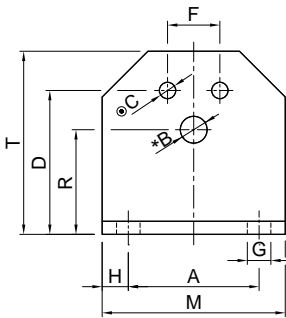

MATERIALS Steel.

TREATMENTS Oven-painted.

USE The bracket SB is used to facilitate the assembly of the elastic element on the machine.



MATERIALI Acciaio.

TRATTAMENTI Verniciatura a forno.

IMPIEGO La staffa SB è utilizzata per facilitare il montaggio dell'elemento elastico sulla macchina.



*

⊙

Type Tipo	Cod. N°	A	Size Taglia	ØB	Size Taglia	ØC	D	E	F	G	H	M	N	O	R	S	T	Weight Peso (kg)
SB 10	RE020510	30	10	6,5	20	5,5	35	13,0	10	7,0	7,5	45	30	11,5	27	4	46	0,09
SB 20	RE020511	40	20	8,5	30	6,5	44	13,0	12	7,0	7,5	55	32	13,5	34	5	58	0,17
SB 30	RE020512	50	30	10,5	40	8,5	55	15,5	20	9,5	10,0	70	38	16,5	43	6	74	0,29
SB 40	RE020513	65	40	12,5	50	10,5	75	21,5	25	11,5	12,5	90	52	21,0	57	8	98	0,72
SB 50	RE020514	80	50	16,5	60	12,5	85	24,0	35	14,0	15,0	110	55	21,0	66	8	116	0,93
SB 60	RE020515	100	60	20,5	70	12,5	110	30,0	40	18,0	20,0	140	66	26,0	80	10	140	1,82



* Hole B is used for the fixation of the CRESA tensioners.

⊙ Holes C are used for the fixation of the VIB elastic elements type: AR-P, AC-P, AD-P, TB, CR-P.



* Il foro B è da utilizzare per il montaggio degli "Elementi tenditori" CRESA.

⊙ I fori C sono da utilizzare per il montaggio degli "Elementi Elastici" VIB tipo: AR-P, AC-P, AD-P, TB, CR-P.

Type - Tipo: **V**

USE Double arm
Braccio doppio

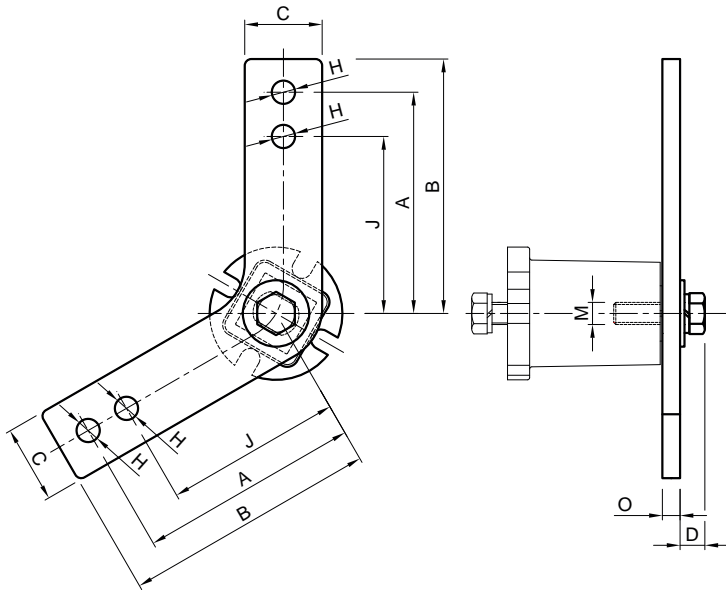

UK MATERIALS Steel.
TREATMENTS Galvanised.
USE The accessory V is applied on the base elements CEB and CEBP in very long transmission systems because it allows "S" form tensioning.

IT MATERIALI Acciaio.
TRATTAMENTI Zincatura.
IMPIEGO L'accessorio V va applicato agli elementi base CEB e CEBP nei sistemi di trasmissione molto lunghi in quanto consente il tensionamento ad "S".

Type Tipo	Cod. N°	A	B	C	D	ØH	J	M	O	Weight Peso (kg)
V 30	RE010997	100	115	35	11,2	10,5	80	M10	8	0,51
V 40	RE010998	130	155	50	13,0	12,5	100	M12	10	1,22

Type - Tipo: **PR**

USE Preloading
Precarica

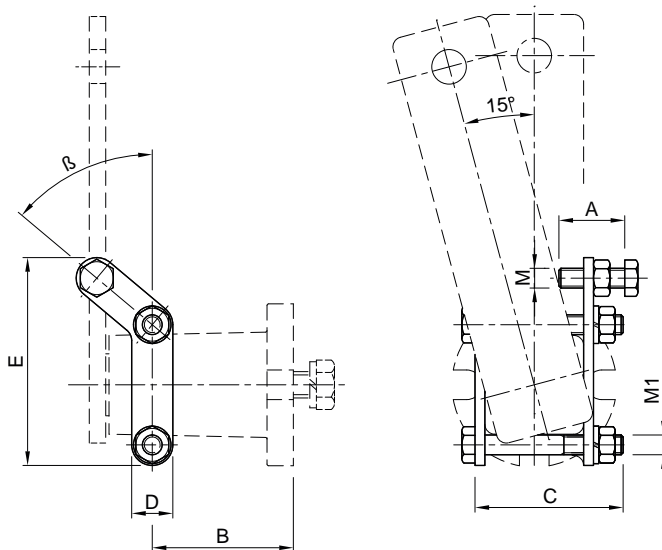

UK MATERIALS Steel.
TREATMENTS Galvanised.
USE This product is suitable for realisation of downholders, calibrators and precision shock absorbers.

IT MATERIALI Acciaio.
TRATTAMENTI Zincatura.
IMPIEGO Questo prodotto è ideale per la realizzazione di gruppi di pressione, calibratori ed ammortizzatori di precisione.

Type Tipo	Cod.N°	β	A	B	C	D	E	M	M1	Weight Peso (kg)
PR 10	RE012470	47,5°	20	34,5	40	12,5	55,8	M6	M6	0,07
PR 20	RE012472	50,0°	20	44,0	45	12,5	63,1	M6	M6	0,07
PR 30	RE012474	45,0°	25	54,2	55	17,0	81,3	M8	M8	0,16
PR 40	RE012476	44,5°	30	75,7	80	16,0	96,5	M10	M8	0,39
PR 50	RE012478	47,0°	45	97,5	100	25,0	142,0	M12	M12	0,76
PR 60	RE012480	42,5°	70	141,0	130	30,0	187,5	M16	M16	1,75
PR 70	RE012482	43,4°	80	144,0	140	40,0	209,7	M20	M16	2,50

Type - Tipo: **SAR**

USE Contrast ring
Anello di contrasto

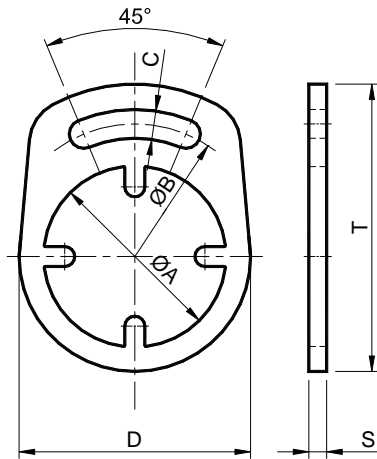

 **MATERIALS** Steel.

TREATMENTS Galvanised.

USE The SAR anti-rotation accessory is used to prevent the rotation of the body when the rear fixing screw of the tensioner does not guarantee the pressure for a stable anchorage.

 **MATERIALI** Acciaio.

TRATTAMENTI Zincatura.

IMPIEGO L'accessorio antirotazione SAR è utilizzato per impedire la rotazione del corpo quando la sola vite di fissaggio posteriore del tenditore non garantisce una pressione sufficiente ad un ancoraggio stabile.

Type Tipo	Cod.N°	A	B	C	D	S	T	Weight Peso (kg)
SAR 30	RE012492	61	45	9	80	6	100	0,25
SAR 40	RE012493	82	60	13	104	8	130	0,35
SAR 50	RE012494	102	75	17	128	10	161	0,65
SAR 60	RE012495	122	90	21	150	12	192	1,60

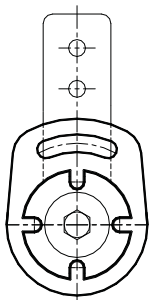

Fig.1

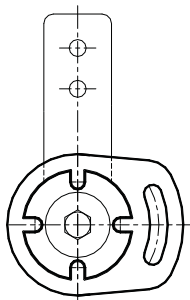

Fig.2

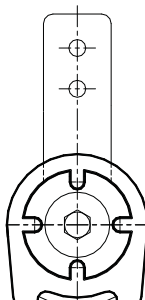

Fig.3

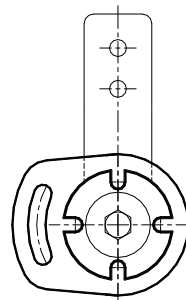

Fig.4

 **CONFIGURATION:**

The CRESA SAR anti-rotation systems allow a positioning in 4 different configurations:

 **CONFIGURAZIONE:**

I sistemi antirotazione CRESA SAR permettono un posizionamento in 4 differenti configurazioni:

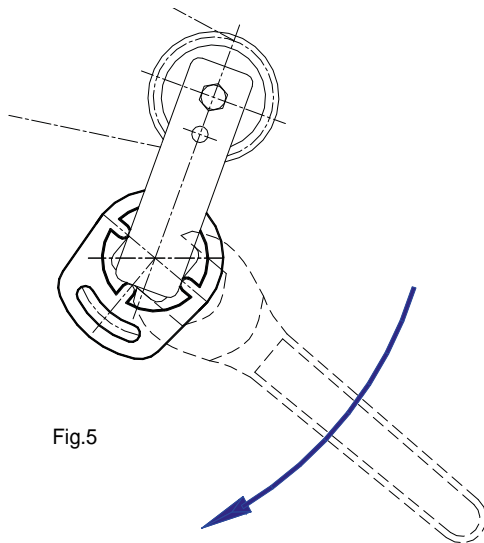

Fig.5

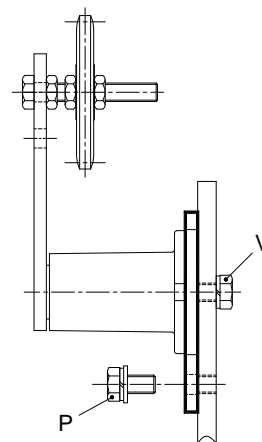



Fig.6

 **ASSEMBLY INSTRUCTIONS:** Fit the tensioner inside the SAR bracket (Fig.5) in one of the 4 positions. Preload the tensioner keeping the V screw loose (Fig.6). Once You reach the wanted preloading angle, tighten the V screw with tightening torque shown in the table at page C-40. Fix with P screw.

 **ISTRUZIONI DI MONTAGGIO:** Il tenditore va inserito all'interno della staffa SAR (Fig.5) in una delle quattro posizioni. Pre caricare il tenditore mantenendo con vite V lenta (Fig.6). Una volta raggiunto l'angolo di pre carico desiderato, tirare la vite V con coppia di serraggio rappresentata in tabella a pagina C-40. Fissare con la vite P.

		CHAIN - CATENA DIN 8187						BELT - CINGHIA			
ISO	Pitch Passo	Type - Tipo					Size Taglia	Type - Tipo		Max belt width Largh. massima cinghia	Type - Tipo
		VR Pag. C-32	OVR Pag. C-32	RO Pag. C-33	ZN Pag. C-34	ZK Pag. C-35		RP Pag. C-37	RU Pag. C-38		
05-B1	8 mm	VR 10-0S	OVR 10-0S	RO 10-0S	-	-	10	RP 1	RU 1	30	-
06-B1	3/8" x 7/32"	VR 10-1S	OVR 10-1S	RO 10-1S	-	-	10	-	-	-	-
06-B1	3/8" x 7/32"	-	-	-	ZN 20-1S	ZK 20-1S	20	-	-	-	-
06-B1	3/8" x 7/32"	-	-	-	ZN 30-1S	ZK 30-1S	30	-	-	-	-
08-B1	1/2" x 5/16"	VR 20-2S	OVR 20-2S	RO 20-2S	-	-	20	RP 2/3	RU 2/3	40	-
08-B1	1/2" x 5/16"	VR 30-2S	OVR 30-2S	RO 30-2S	ZN 30-2S	ZK 30-2S	30	RP 2/3	RU 2/3	40	SPZ
10-B1	5/8" x 3/8"	VR 30-3S	OVR 30-3S	RO 30-3S	ZN 30-3S	-	30	-	-	-	-
10-B1	5/8" x 3/8"	-	-	-	ZN 40-3S	ZK 40-3S	40	-	-	-	SPA
12-B1	3/4" x 7/16"	VR 30-4S	OVR 30-4S	RO 30-4S	ZN 30-4S	-	30	-	-	-	-
12-B1	3/4" x 7/16"	VR 40-4S	OVR 40-4S	RO 40-4S	ZN 40-4S	ZK 40-4S	40	RP 4	RU 4	55	SPB
12-B1	3/4" x 7/16"	-	-	-	ZN 50-4S	ZK 50-4S	50	-	-	-	-
16-B1	1" x 17,02mm	VR 40-5S	-	RO 40-5S	ZN 40-5S	-	40	-	-	-	-
16-B1	1" x 17,02mm	-	-	-	ZN 50-5S	ZK 50-5S	50	RP 5	RU 5	85	-
20-B1	1"1/4 x 3/4"	VR 50-6S	-	RO 50-6S	-	-	50	-	-	-	-
20-B1	1"1/4 x 3/4"	-	-	-	ZN 60-6S	ZK 60-6S	60	-	-	-	-
24-B1	1"1/2 x 1"	VR 50-7S	-	RO 50-7S	-	-	50	-	-	-	-
24-B1	1"1/2 x 1"	-	-	-	ZN 60-7S	ZK 60-7S	60	RP 6	RU 6	130	-
05-B2	8 mm	VR 10-0D	OVR 10-0D	RO 10-0D	-	-	10	-	-	-	-
06-B2	3/8" x 7/32"	VR 10-1D	OVR 10-1D	RO 10-1D	-	-	10	-	-	-	-
06-B2	3/8" x 7/32"	-	-	-	ZN 20-1D	ZK 20-1D	20	-	-	-	-
06-B2	3/8" x 7/32"	-	-	-	ZN 30-1D	ZK 30-1D	30	-	-	-	-
08-B2	1/2" x 5/16"	VR 20-2D	OVR 20-2D	RO 20-2D	-	-	20	-	-	-	-
08-B2	1/2" x 5/16"	VR 30-2D	OVR 30-2D	RO 30-2D	ZN 30-2D	ZK 30-2D	30	-	-	-	SPZ
10-B2	5/8" x 3/8"	VR 30-3D	OVR 30-3D	RO 30-3D	ZN 30-3D	-	30	-	-	-	-
10-B2	5/8" x 3/8"	-	-	-	ZN 40-3D	ZK 40-3D	40	-	-	-	SPA
12-B2	3/4" x 7/16"	VR 30-4D	OVR 30-4D	RO 30-4D	-	-	30	-	-	-	-
12-B2	3/4" x 7/16"	VR 40-4D	OVR 40-4D	RO 40-4D	ZN 40-4D	ZK 40-4D	40	-	-	-	SPB
12-B2	3/4" x 7/16"	-	-	-	ZN 50-4D	ZK 50-4D	50	-	-	-	-
16-B2	1" x 17,02mm	VR 40-5D	-	RO 40-5D	ZN 40-5D	-	40	-	-	-	-
16-B2	1" x 17,02mm	VR 50-5D	-	RO 50-5D	ZN 50-5D	ZK 50-5D	50	-	-	-	-
20-B2	1"1/4 x 3/4"	VR 50-6D	-	RO 50-6D	-	-	50	-	-	-	-
20-B2	1"1/4 x 3/4"	-	-	-	ZN 60-6D	ZK 60-6D	60/70	-	-	-	-
24-B2	1"1/2 x 1"	VR 50-7D	-	RO 50-7D	-	-	50	-	-	-	-
24-B2	1"1/2 x 1"	-	-	-	ZN 60-7D	ZK 60-7D	60/70	-	-	-	-
06-B3	3/8" x 7/32"	VR 20-1T	-	RO 20-1T	-	-	20	-	-	-	-
06-B3	3/8" x 7/32"	-	-	-	ZN 30-1T	ZK 30-1T	30	-	-	-	SPZ
08-B3	1/2" x 5/16"	VR 30-2T	-	RO 30-2T	-	-	30	-	-	-	-
08-B3	1/2" x 5/16"	-	-	-	ZN 40-2T	ZK 40-2T	40	-	-	-	SPA
10-B3	5/8" x 3/8"	VR 40-3T	-	RO 40-3T	ZN 40-3T	ZK 40-3T	40	-	-	-	-
10-B3	5/8" x 3/8"	-	-	-	ZN 50-3T	ZK 50-3T	50	-	-	-	-
12-B3	3/4" x 7/16"	VR 40-4T	-	RO 40-4T	ZN 40-4T	-	40	-	-	-	-
12-B3	3/4" x 7/16"	-	-	-	ZN 50-4T	ZK 50-4T	50	-	-	-	SPB
16-B3	1" x 17,02mm	VR 40-5T	-	RO 40-5T	-	-	40	-	-	-	-
16-B3	1" x 17,02mm	VR 50-5T	-	RO 50-5T	ZN 50-5T	-	50	-	-	-	-
16-B3	1" x 17,02mm	-	-	-	ZN 60-5T	ZK 60-5T	60	-	-	-	-
20-B3	1"1/4 x 3/4"	VR 50-6T	-	RO 50-6T	-	-	50	-	-	-	-
20-B3	1"1/4 x 3/4"	-	-	-	ZN 60-6T	ZK 60-6T	60/70	-	-	-	-
24-B3	1"1/2 x 1"	VR 50-7T	-	RO 50-7T	-	-	50	-	-	-	-
24-B3	1"1/2 x 1"	-	-	-	ZN 60-7T	ZK 60-7T	60/70	-	-	-	-

 Red codes on request.

 Codici in rosso a richiesta.

Type - *Tipo*: VR

USE Semi-circular sliding block
Pattino semicircolare

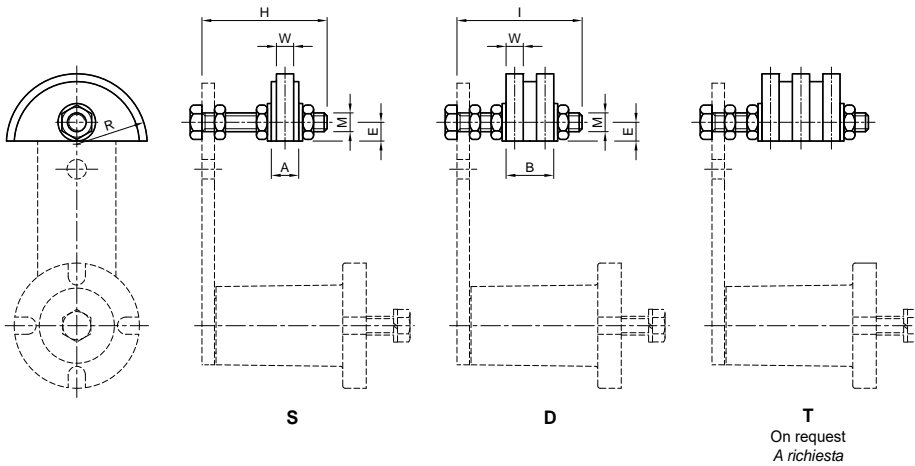

UK MATERIALS High density polyethylene. Bolts and nuts are made of galvanized steel.
USE For short wheel-base or for installation close to the pinion.
Speed ≤ 20 m/min. Temperature $\leq 70^\circ\text{C}$.

IT MATERIALI Polietilene ad alta densità. Bulloneria in acciaio zincato.
IMPIEGO Per piccoli interassi o per montaggi vicino al pignone.
Velocità ≤ 20 m/min. Temperatura $\leq 70^\circ\text{C}$.

C



Size
Taglia

Type <i>Tipo</i>	S Cod.N°	D Cod.N°	Chain <i>Catena</i>	Type <i>Tipo</i>	S Cod.N°	D Cod.N°		A	B	E	G	H	I	M	P	Q	R	W	Weight <i>Peso</i> (kg)	
																			S	D
VR 10-0	RE011110	RE011150	05-B 8 mm	-	-	-	10	10,0	12,0	10		45	45	M8			35	2,5	0,09	0,10
VR 10-1	RE011111	RE011152	06-B 3/8"	OVR 10-1	RE011030	RE011040	10	10,0	18,0	10	10,2	45	45	M8	75	40	35	5,0	0,09	0,10
VR 20-1	-	-	06-B 3/8"	-	-	-	20	-	-	10	-	-	-	M10	-	-	35	5,0	-	-
VR 20-2	RE011113	RE011155	08-B 1/2"	OVR 20-2	RE011032	RE011042	20	14,0	20,5	10	13,9	55	55	M10	96	50	35	7,0	0,10	0,11
VR 30-2	RE011114	RE011156	08-B 1/2"	OVR 30-2	RE011032	RE011044	30	14,0	20,5	10	13,9	55	60	M10	96	50	35	7,0	0,11	0,12
VR 30-3	RE011117	RE011160	10-B 5/8"	OVR 30-3	RE011034	RE011046	30	16,5	25,0	12	16,6	55	70	M10	126	65	45	9,0	0,12	0,14
VR 40-3	-	-	10-B 5/8"	-	-	-	40	-	-	12	-	-	-	M12	-	-	45	9,0	-	-
VR 30-4	RE011120	RE011163	12-B 3/4"	OVR 30-4	RE011036	RE011048	30	17,5	30,0	12	19,5	60	70	M10	148	74	45	11,0	0,13	0,15
VR 40-4	RE011121	RE011164	12-B 3/4"	OVR 40-4	RE011038	RE011050	40	17,5	30,0	12	19,5	80	80	M12	148	74	45	11,0	0,20	0,22
VR 40-5	RE011124	RE011167	16-B 1"	-	-	-	50	18,0	47,0	20		80	90	M12	-	-	55	16,0	0,22	0,31
VR 50-5	-	RE011168	16-B 1"	-	-	-	50	-	47,0	20	-	-	100	M20	-	-	55	16,0	-	0,68
VR 50-6	RE011128	RE011172	20-B 1 1/4"	-	-	-	50	20,0	54,0	20	-	100	120	M20	-	-	55	18,0	0,59	0,74
VR 50-7	RE011134	RE011176	24-B 1 1/2"	-	-	-	50	24,0	72,0	20	-	100	120	M20	-	-	55	24,0	0,61	0,77



Type - *Tipo*: OVR

USE Oval sliding block
Pattino ovale

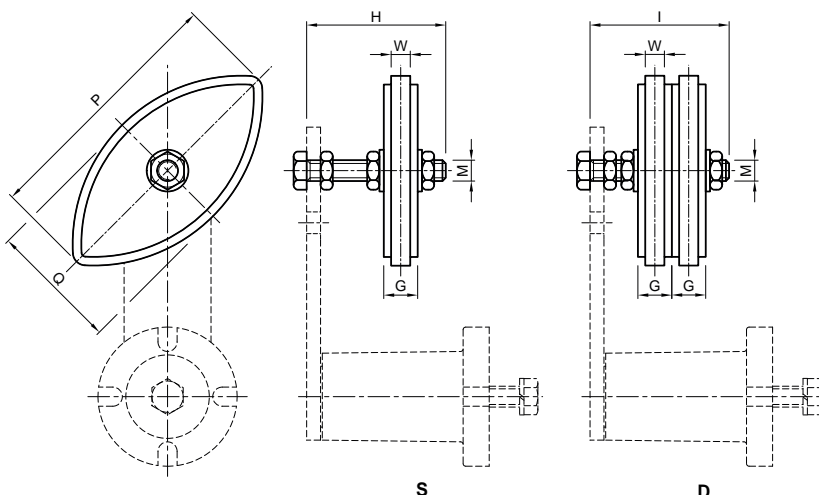

UK MATERIALS High density polyethylene. Bolts and nuts are made of galvanized steel.
USE For middle-size and large distances between centres.
Speed ≤ 20 m/min. Temperature $\leq 70^\circ\text{C}$.

IT MATERIALI Polietilene ad alta densità. Bulloneria in acciaio zincato.
IMPIEGO Per medi e grandi interassi.
Velocità ≤ 20 m/min. Temperatura $\leq 70^\circ\text{C}$.

Type - *Tipo*: RO

USE Idler wheel
Rotella



 **MATERIALS** High density polyethylene. Bush, bolts and nuts are made of galvanized steel.

USE Idler wheel on the bush.
Speed ≤30 m/min. Temperature ≤70°C.

 **MATERIALI** Polietilene ad alta densità . Bussola e bulloneria in acciaio zincato.

IMPIEGO Rotella folle su bussola.
Velocità ≤30 m/min. Temperatura ≤70°C.

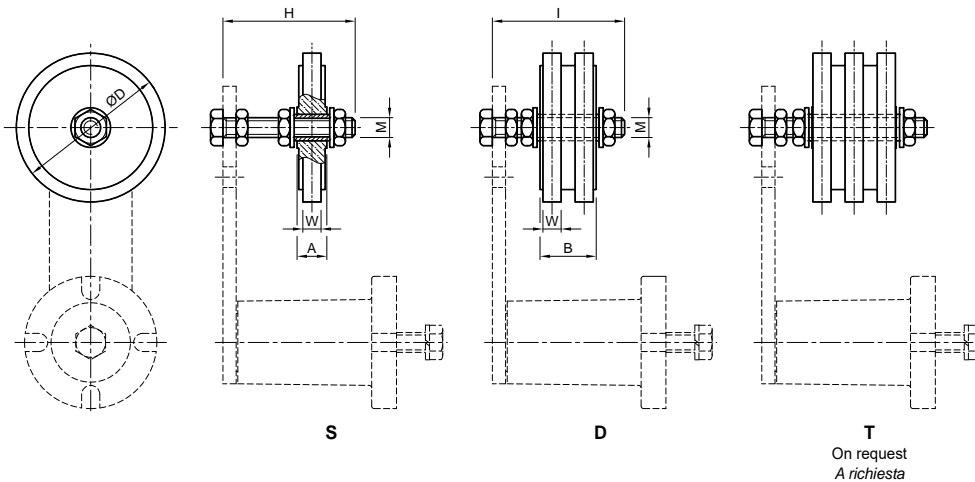

Size
Taglia

Type <i>Tipo</i>	S Cod.N°	D Cod.N°	Chain <i>Catena</i>		A	B	ØD	H	I	M	W	Weight <i>Peso (kg)</i>	
												S	D
RO 10-0	RE011350	RE011388	05-B 8 mm	10	18	18	70	45	45	M8	2,5	0,14	0,15
RO 10-1	RE011351	RE011389	06-B 3/8"	10	18	18	70	45	50	M8	5,0	0,14	0,15
RO 20-2	RE011353	RE011392	08-B 1/2"	20	18	36	70	55	55	M10	7,0	0,15	0,20
RO 30-2	RE011354	RE011393	08-B 1/2"	30	18	36	70	55	60	M10	7,0	0,16	0,22
RO 30-3	RE011357	RE011397	10-B 5/8"	30	18	36	90	55	70	M10	9,0	0,19	0,28
RO 30-4	RE011360	RE011400	12-B 3/4"	30	18	36	90	55	70	M10	11,0	0,19	0,29
RO 40-4	RE011361	RE011401	12-B 3/4"	40	18	36	90	80	80	M12	11,0	0,25	0,35
RO 40-5	RE011364	RE011404	16-B 1"	40	18	49	110	80	90	M12	16,0	0,32	0,56
RO 50-6	RE011369	RE011409	20-B 1"1/4	50	19	57	110	100	120	M20	18,0	0,57	0,83
RO 50-7	RE011373	RE011413	24-B 1"1/4	50	26	75	110	100	120	M20	24,0	0,63	1,00

Type - Tipo: **ZN**

USE Oversized idler sprocket
Pignone maggiorato



 **MATERIALI** Sprocket, bearing, bolts and nuts are made of steel.
TREATMENTS Galvanization.
USE Idler sprocket national bearings.
Speed ≤ 60m/min. Temperature ≤ 100°C.

 **MATERIALI** Corona, cuscinetto e vite in acciaio.
TRATTAMENTI Zincatura.
IMPIEGO Pignone con cuscinetto nazionale.
Velocità ≤ 60 m/min. Temperatura ≤ 100°C.

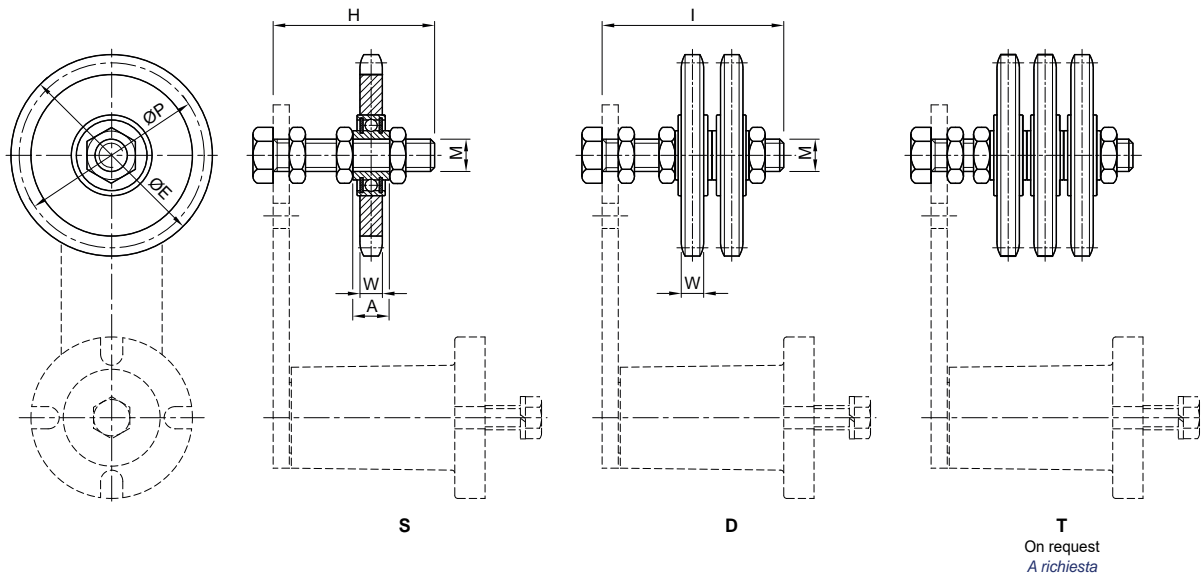

Size
Taglia

Type Tipo	S Cod.N°	D Cod.N°	Chain Catena		A	ØE	H	I	M	ØP	W	Z	Weight Peso (kg)	
													S	D
ZN 20-1	RE011470	RE011507	06-B 3/8"	20	18,3	68,0	55	55	M16	63,90	5,3	21	0,29	0,41
ZN 30-1	RE011471	RE011508	06-B 3/8"	30	18,3	68,0	55	60	M16	63,90	5,3	21	0,29	0,42
ZN 30-2	RE011474	RE011511	08-B 1/2"	30	18,3	77,8	55	60	M16	73,14	7,2	18	0,39	0,62
ZN 30-3	RE011477	RE011514	10-B 5/8"	30	18,3	93,0	60	70	M16	86,39	9,1	17	0,54	0,91
ZN 40-3	RE011478	RE011515	10-B 5/8"	40	18,3	93,0	80	90	M16	86,39	9,1	17	0,57	0,94
ZN 40-4	RE011481	RE011518	12-B 3/4"	40	18,3	99,8	80	90	M16	91,63	11,1	15	0,69	1,18
ZN 50-4	RE011482	RE011519	12-B 3/4"	50	18,3	99,8	80	90	M16	91,63	11,1	15	0,70	1,20
ZN 40-5	RE011485	RE011521	16-B 1"	40	18,3	109,0	80	120	M20	98,14	16,2	12	1,05	1,83
ZN 50-5	RE011486	RE011522	16-B 1"	50	17,7	109,0	100	120	M20	98,14	16,2	12	1,09	1,87
ZN 60-6	RE011490	RE011527	20-B 1 1/4"	60/70	21,0	147,8	100	160	M20	132,65	18,5	13	2,19	4,11
ZN 60-7	RE011494	RE011531	24-B 1 1/2"	60/70	21,0	150,0	140	180	M20	135,21	24,1	11	2,37	4,31

Type - Tipo: **ZK**

USE Idler sprocket
Pignone base



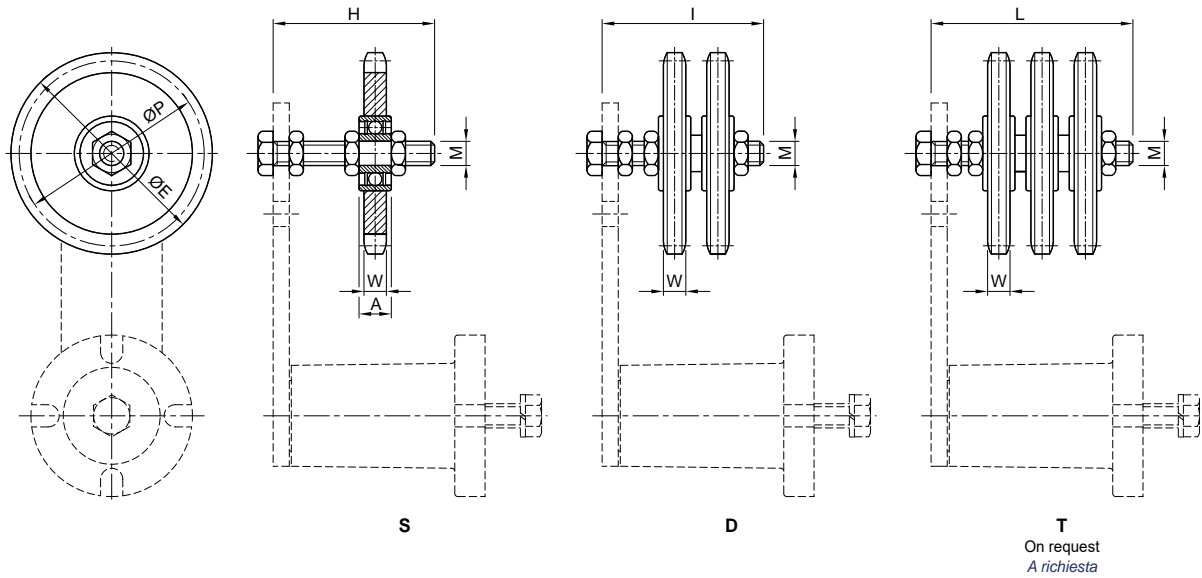

UK MATERIALS Sprocket, bearing, bolts and nuts are made of steel.
TREATMENTS Galvanization.
USE Idler sprocket.
Speed ≤ 60m/min. Temperature ≤ 100°C.

IT MATERIALI Corona, cuscinetto e bulloneria in acciaio.
TRATTAMENTI Zincatura.
IMPIEGO Pignone con cuscinetto unificato.
Velocità ≤ 60 m/min. Temperatura ≤ 100°C.



Size
Taglia

Type Tipo	S Cod.N°	D Cod.N°	T Cod.N°	Chain Catena		A	ØE	H	I	L	M	ØP	W	Z	Weight Peso (kg)		
															S	D	T
ZK 20-1	RE011690	RE011727	-	06-B 3/8"	20	9	49,3	55	55	-	M10	45,81	5,3	15	0,13	0,23	-
ZK 30-1	RE011691	RE011728	RE011764	06-B 3/8"	30	9	49,3	55	60	70	M10	45,81	5,3	15	0,13	0,23	0,26
ZK 30-2	RE011694	RE011731	-	08-B 1/2"	30	9	65,5	55	60	-	M10	61,09	7,2	15	0,21	0,37	-
ZK 40-2	RE011695	RE011732	RE011768	08-B 1/2"	40	12	65,5	80	80	80	M12	61,09	7,2	15	-	-	0,51
ZK 40-3	RE011698	RE011735	RE011771	10-B 5/8"	40	12	83,0	80	80	80	M12	76,36	9,1	15	0,38	0,60	0,96
ZK 50-3	-	-	RE011772	10-B 5/8"	50	15	83,0	-	-	120	M20	76,36	9,1	15	-	-	1,26
ZK 40-4	RE011701	RE011738	-	12-B 3/4"	40	12	99,8	80	80	-	M12	91,63	11,1	15	0,56	1,00	-
ZK 50-4	RE011702	RE011739	RE011776	12-B 3/4"	50	15	99,8	100	120	120	M20	91,63	11,1	15	0,81	1,35	1,60
ZK 50-5	RE011706	RE011743	-	16-B 1"	50	15	117,0	100	120	-	M20	106,12	16,2	13	1,23	2,10	-
ZK 60-5	-	-	RE011780	16-B 1"	60	15	117,0	-	-	160	M20	106,12	16,2	13	-	-	2,92
ZK 60-6	RE011710	RE011747	RE011784	20-B 1 1/4"	60/70	15	147,8	100	140	160	M20	132,65	18,5	13	2,28	3,60	5,20
ZK 60-7	RE011714	RE011751	RE011788	24-B 1 1/2"	60/70	15	150,0	140	140	180	M20	135,21	24,1	11	2,33	4,20	6,10

Type - Tipo: **K**

USE Idler sprocket
 Corona con cuscinetto

 **MATERIALS** Sprocket, bearing, bolts and nuts are made of steel.
TREATMENTS Galvanization.
USE Idler sprocket.
 Speed ≤ 60 m/min. Temperature $\leq 100^{\circ}\text{C}$.

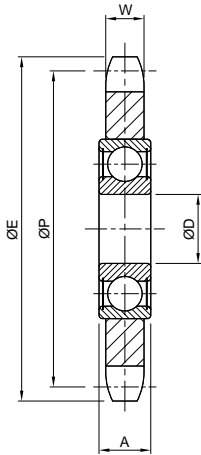
 **MATERIALI** Corona, cuscinetto e bulloneria in acciaio.
TRATTAMENTI Zincatura.
IMPIEGO Il pignone con cuscinetto unificato.
 Velocità ≤ 60 m/min. Temperatura $\leq 100^{\circ}\text{C}$.





Type Tipo	Cod.N°	Chain Catena	A	ØD	ØE	ØP	W	Z	Weight Peso (kg)
K Z15 3/8"-10	RE001510	06-B1 3/8"	9	10	49,3	45,81	5,3	15	0,059
K Z15 1/2"-10	RE001514	08-B1 1/2"	9	10	65,5	61,09	7,2	15	0,132
K Z15 1/2"-12	RE001516	08-B1 1/2"	12	12	65,5	61,09	7,2	15	0,139
K Z15 5/8"-12	RE001520	10-B1 5/8"	12	12	83,0	76,36	9,1	15	0,260
K Z15 5/8"-20	RE001522	10-B1 5/8"	15	20	83,0	76,36	9,1	15	0,275
K Z15 3/4"-12	RE001526	12-B1 3/4"	12	12	99,8	91,63	11,1	15	0,468
K Z15 3/4"-20	RE001528	12-B1 3/4"	15	20	99,8	91,63	11,1	15	0,463
K Z13 1"-20	RE001532	16-B1 1"	15	20	117,0	106,12	16,2	13	0,853
K Z13 1"1/4-20	RE001536	20-B1 1"1/4	15	20	147,8	132,65	18,5	13	1,622
K Z11 1"1/2-20	RE001540	24-B1 1"1/2	15	20	150,0	135,21	24,1	11	1,974

Type - Tipo: RP

USE Plastic roller
Rullo in plastica



 **MATERIALS** PA6+MoS. Bearings and spacers are made of steel.
TREATMENTS Galvanization.
USE Belt tensioner roller.
Roller temperature $\leq 70^{\circ}\text{C}$.

 **MATERIALI** PA6+MoS nero, cuscinetti e distanziali in acciaio.
TRATTAMENTI Zincatura.
IMPIEGO Rullo per tendicinghia.
Temperatura dei rulli $\leq 70^{\circ}\text{C}$.

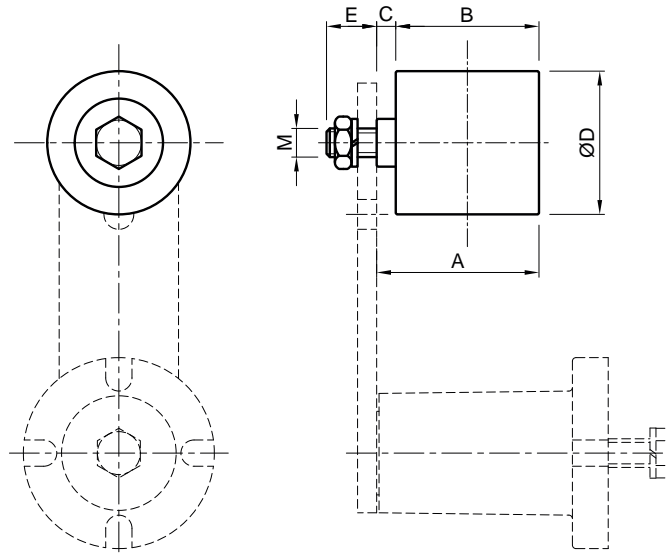

Size
Taglia

Type Tipo	Cod. N°		A	B	C	ØD	E	M	Max. speed Velocità max. (rpm)	Weight Peso (kg)
RP 1	RE011090	10	38	35	3	30	13	M 8	8000	0,08
RP 2/3	RE011092	20-30	51	45	6	40	16	M10	8000	0,18
RP 4	RE011094	40	68	60	8	60	22	M12	6000	0,40
RP 5	RE011096	50	99	90	9	80	28	M20	5000	1,20
RP 6	RE011098	60	142	135	7	90	27	M20	4500	1,70

NOTE: The rpm indicated in the table is approximate. The application must be considered according to the use, the service factor and working conditions.
Il numero di giri descritto in tabella è indicativo. L'applicazione va valutata in base al tipo d'impiego, il fattore di servizio e le condizioni di lavoro.

Type - *Tipo*: RU

USE Steel roller
Rullo in acciaio

MATERIALS Made of steel.
TREATMENTS Galvanization.
USE Temperature $\leq 100^{\circ}\text{C}$.

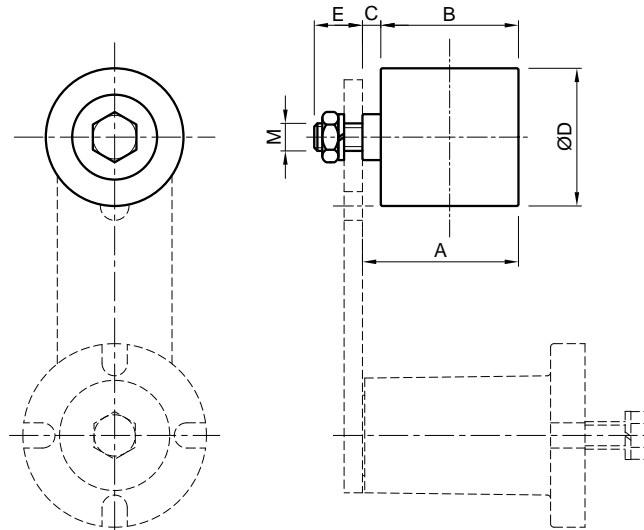
MATERIALI In acciaio.
TRATTAMENTI Zincatura.
IMPIEGO Temperatura $\leq 100^{\circ}\text{C}$.

 Size
 Taglia

Type <i>Tipo</i>	Cod. N°		A	B	C	ØD	E	M	Max. speed <i>Velocità max.</i> (rpm)	Weight <i>Peso</i> (kg)
RU 1	AR070870	10	38	35	3	30	13	M8	15000	0,16
RU 2/3	AR070872	20-30	51	45	6	40	16	M10	12000	0,37
RU 4	AR070874	40	68	60	8	60	21	M12	9500	0,85
RU 5	AR070876	50	99	90	9	80	28	M20	6500	2,09
RU 6	AR070878	60	142	135	7	90	27	M20	6500	2,44

NOTE: The rpm indicated in the table is approximate. The application must be considered according to the use, the service factor and working conditions.

The customer must widen the hole on the elastic element where necessary.

Il numero di giri descritto in tabella è indicativo. L'applicazione va valutata in base al tipo d'impiego, il fattore di servizio e le condizioni di lavoro.

Sarà a cura del cliente allargare il foro sull'elemento elastico dove necessario.

Type - *Tipo*: **SP (Z-A-B)**

USE Trapezoidal pulley
Puleggia trapezoidale



 **MATERIALS** Cast iron. Spacers, bearings, bolts and nuts are made of steel.
TREATMENTS Galvanization on steel.
USE Pulley for V-belts tensioning. Temperature ≤ 100°C.

 **MATERIALI** Ghisa. Distanziali cuscinetti e bulloneria acciaio.
TRATTAMENTI Zincatura su metallo.
IMPIEGO Puleggia per il tensionamento di cinghie trapezoidali.
Temperatura ≤ 100°C.

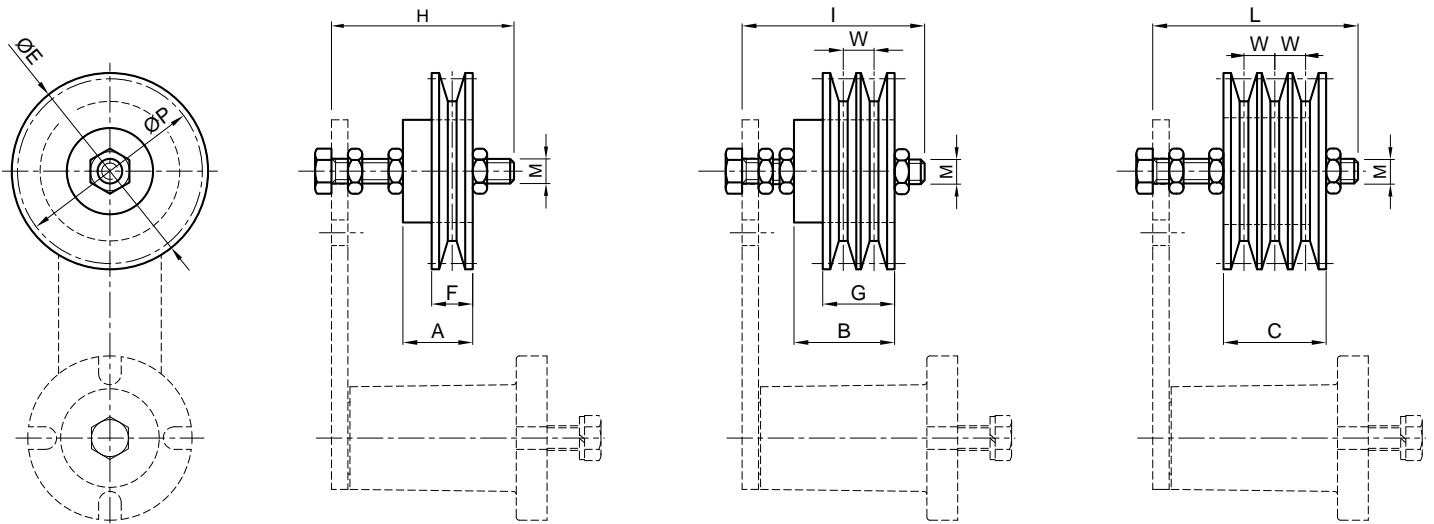

Size
Taglia

Type <i>Tipo</i>	S Cod. N°	D Cod. N°	T Cod. N°	Belt <i>Cinghia</i>		A	B	C	ØE	F	G	H	I	L	M	ØP	W	Max. speed <i>Velocità max.</i> (rpm)	Weight <i>Peso</i> (kg)			
																			S	D	T	
SP 30-Z 63	RE011800	RE011802	RE011804	SPZ		30	24	35	40	67,0	16	28	55	60	70	M10	63	12	10000	0,40	0,70	1,10
SP 30-Z 90	RE011801	RE011802	RE011805	SPZ		30	24	35	40	94,0	16	28	55	60	70	M10	90	12	10000	1,20	1,50	1,85
SP 40-A 90	RE011806	RE011808	RE011810	SPA		40	34	45	50	95,6	20	35	80	80	80	M12	90	15	7400	1,00	1,70	1,80
SP 50-A 125	RE01107	RE011809	-	SPA		50	40	45	-	130,5	20	35	100	100	-	M20	125	15	5300	2,00	3,00	-
SP 40-B 125	RE011812	RE011814	-	SPB		40	41	55	-	132,0	-	44	80	90	-	M12	125	19	7400	1,90	2,80	-
SP 50-B 125	-	-	RE011816	SPB		50	-	-	63	132,0	-	-	-	-	120	M20	125	19	5300	-	-	3,50
SP 50-B 140	-	-	RE011817	SPB		50	-	-	63	147,0	-	-	-	-	120	M20	140	19	4000	-	-	5,00

NOTE: The rpm indicated in the table is approximate. The application must be considered according to the use, the service factor and working conditions.
On request we can supply the pulley with the pin welded on the lever
Il numero di giri descritto in tabella è indicativo. L'applicazione va valutata in base al tipo d'impiego, il fattore di servizio e le condizioni di lavoro.
A richiesta possiamo fornire la puleggia con il perno saldato alla leva

ASSEMBLY INSTRUCTIONS
ISTRUZIONI DI MONTAGGIO

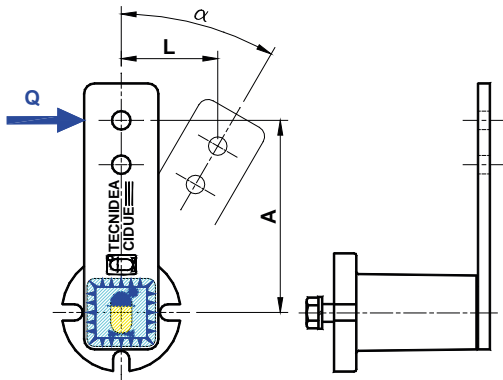

Type Tipo	Torque Mt in Nm Coppia di serraggio Mt in Nm							Screw quality Qualità vite
	Size / Taglia							
	10	20	30	40	50	60	70	
RE	10	25	49	89	210	410	750	8.8
FE	7	17	41	83	145	355	690	8.8

Type Tipo	Preloading angle $\alpha \leq 10^\circ$ Angolo di precarica $\alpha \leq 10^\circ$		Preloading angle $\alpha \leq 20^\circ$ Angolo di precarica $\alpha \leq 20^\circ$		Preloading angle $\alpha \leq 30^\circ$ Angolo di precarica $\alpha \leq 30^\circ$		Type Tipo
	Arm / Braccio A		Arm / Braccio A		Arm / Braccio A		
	Q (N)	L (mm)	Q (N)	L (mm)	Q (N)	L (mm)	
RE 10	16	14	45	28	90	40	FE 10
RE 20	26	17	68	34	140	50	FE 20
RE 30	80	17	195	34	380	50	FE 30
RE 40	160	22	400	44	860	65	FE 40
RE 50	300	30	775	60	1600	87	FE 50
RE 60	530	39	1350	78	2700	112	FE 60
RE 70	760	43	2200	86	4400	125	FE 70

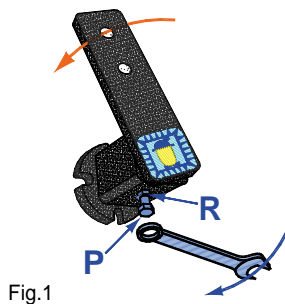

Fig.1

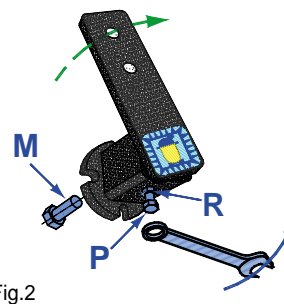

Fig.2

UK Preload the tensioner on work table and tight P screw with a wrench until it stops, then fix also R nut (Figure 1). The tensioner will remain in the position. Mount the tensioner on the machine and after fixing it with M screw, loosen R nut and P screw (Figure 2).

IT Pre caricare a banco il tenditore ed avvitare con una chiave la vite P fino al riscontro, poi fissare il dado R (Figura 1). Il tenditore rimarrà bloccato nella posizione. Montare il tenditore sulla macchina e dopo averlo fissato con la vite M, allentare il dado R e la vite P (Figura 2).

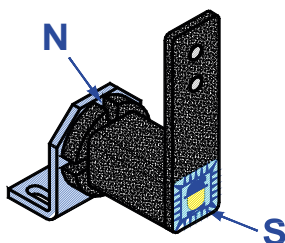

Fig.3

UK The label S, positioned on elastic tensioner, helps the identification the preloading angle. The hole N is used to fix the body, in order to create a stronger fixing of the element itself.

IT L'etichetta S, posta sull'elemento elastico, aiuta ad individuare l'angolo di precarica. La nicchia N viene utilizzata per fissare il corpo, rendendo così più sicuro l'ancoraggio dell'elemento stesso.

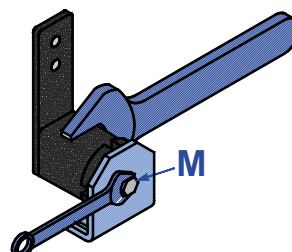

Fig.4

UK In order to preload the tensioner, you only have to loosen the screw M and rotate the wrench on the body until You reach the desired angle. Lock again the M screw, with Mt fixing torque.

IT Per precaricare il tenditore è sufficiente allentare la vite M e ruotare la chiave posta sul corpo, fino a raggiungere l'angolo voluto. Bloccare nuovamente la vite M, con coppia di serraggio Mt.

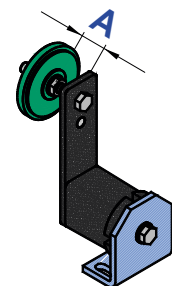

Fig.5

UK When you need to mount the KIT externally, A measure must be reduced and the force Q must be 50% lower than the one indicated in the table.

IT Quando è necessario il montaggio del KIT verso l'esterno, la quota A deve essere ridotta, e la forza Q deve essere inferiore del 50% di quella indicata in tabella

APPLICATION EXAMPLES
ESEMPI DI APPLICAZIONE



C



MINING - QUARRY
CAVE - INERTI



WOOD
LEGNO



TOBACCO
TABACCO



RECYCLING
RICICLAGGIO

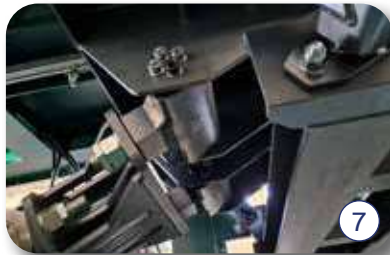

FOOD
ALIMENTARE



PLAYGROUND
PARCHI GIOCHI



ROAD SWEEPERS
SPAZZATRICI



C