

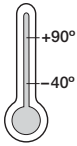

DryLin® T | Linear Guide System

DryLin® T linear guide systems were originally developed for applications in both automation and materials handling. The goal was to create a high performance, maintenance-free linear guide for use in the most diverse, even extreme environments.



DryLin® T

Technical Data

Sliding elements:	Maintenance-free
Material:	iglidur® J*
Max. surface speed:	15 m/s
Temperature range:	-40 °C to +90 °C

* Other materials upon request

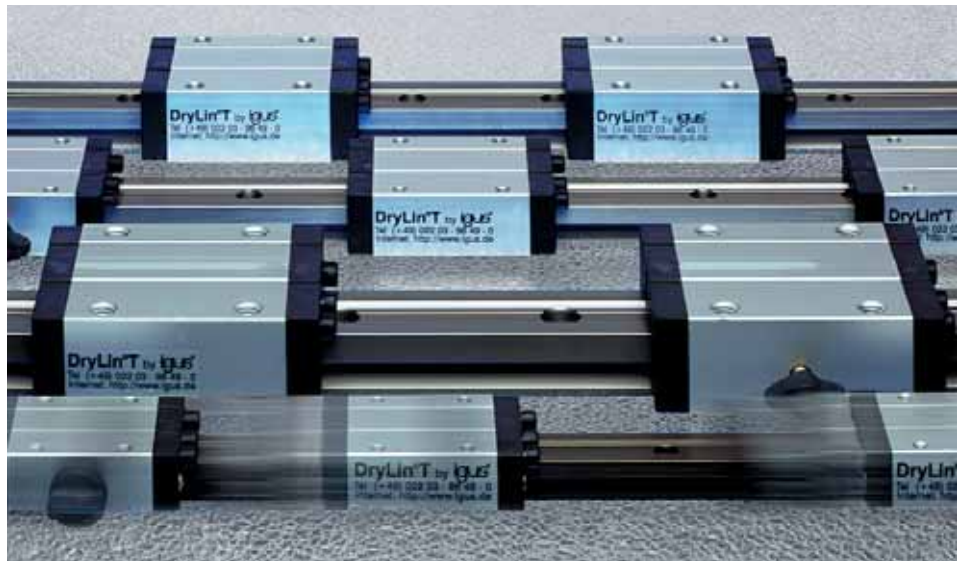

Phone +44 (0) 16 04 - 67 72 40
Fax +44 (0) 16 04 - 67 72 45



DryLin® linear guide system in a treatment machine



Valve machining produces an extreme environment

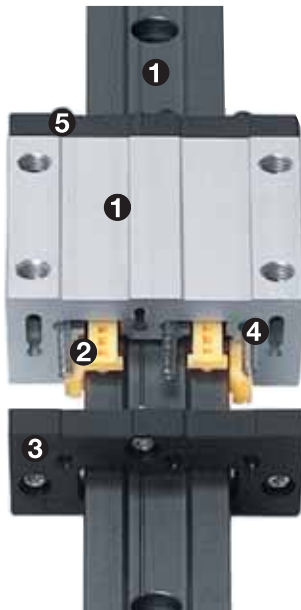

- ❶ Slide rails and base structure of the carriages manufactured from aluminium Al Mg Si 0.5
The rail is hard anodized, the aluminium carriage housing is clear anodized
- ❷ 6 sliding iglidur® J elements act as guide bearings, which are set in opposing pairs and act as three guide bearings altogether
- ❸ Each of the three guide bearings can be adjusted manually or automatically
- ❹ All steel parts are galvanized or stainless steel
- ❺ The end plate is solid plastic

iglus® UK Ltd



DryLin® T linear guide system in pneumatic doors of tool changers

Technical Data

Guide rails	
Material	Aluminium, extruded section
Substance	Al Mg Si 0,5
Coating	Hard anodized aluminium, 50 µm
Hardness	500 HV
Sliding carriage	
Base structure	Aluminium, extruded section
Material	Al Mg Si 0,5
Coating	Anodized aluminium
Sliding elements	Maintenance-free plain bearing iglidur® J
Bolts, springs	Stainless steel, galvanized steel
Cover	Plastic
Max. surface speed	15 m/s
Temperature range	-40 °C to +90 °C

Internet www.igus.co.uk
E-mail sales_uk@igus.co.uk



Special properties

- With a low rate of inertia, high accelerations and short term extreme speeds up to 30 m/s are possible
- DryLin®T linear guide systems run dry. Dirt cannot settle in lubricants
- Recommended for use in food, medical, and clean room technologies, as no lubricants are present
- The corrosion resistance of DryLin® T means that it can also be used in wet environments
- High pressure washdown does not damage the system
- Vibration dampening and extremely quiet operation
- The aluminium rail provides good thermal dissipation. The aluminium only retains heat at continuously high speeds
- The combination of anodized aluminium and iglidur® J results in a low initial breakaway force
- DryLin® T is dimensionally interchangeable with standard ball bearing systems



Picture 60.1: DryLin® T in a demanding packaging machine application

Type	C_{0Y} [kN]	$C_{0(-Y)}$ [kN]	C_{0Z} [kN]	M_{0X} [Nm]	M_{0Y} [Nm]	M_{0Z} [Nm]
04-09	0,48	0,48	0,24	3,4	1,8	1,8
04-12	0,96	0,96	0,48	9,2	4,4	4,4
04-15	1,4	1,4	0,7	17	8	8
01-15	4	4	2	32	25	25
01-20	7,4	7,4	3,7	85	45	45
01-25	10	10	5	125	65	65
01-30	14	14	7	200	100	100

Table 61.1: DryLin® T-01 – Permissible static load capacity

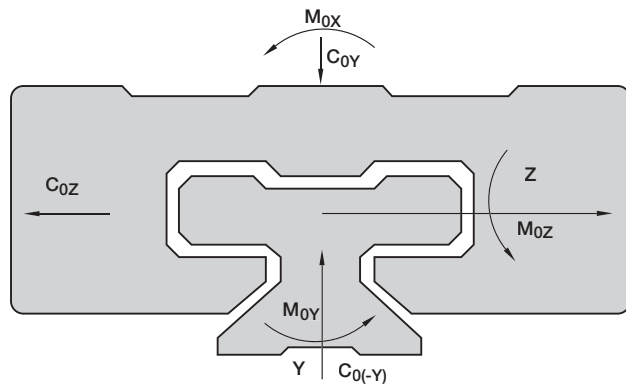

Graph 61.1: Designation of load directions

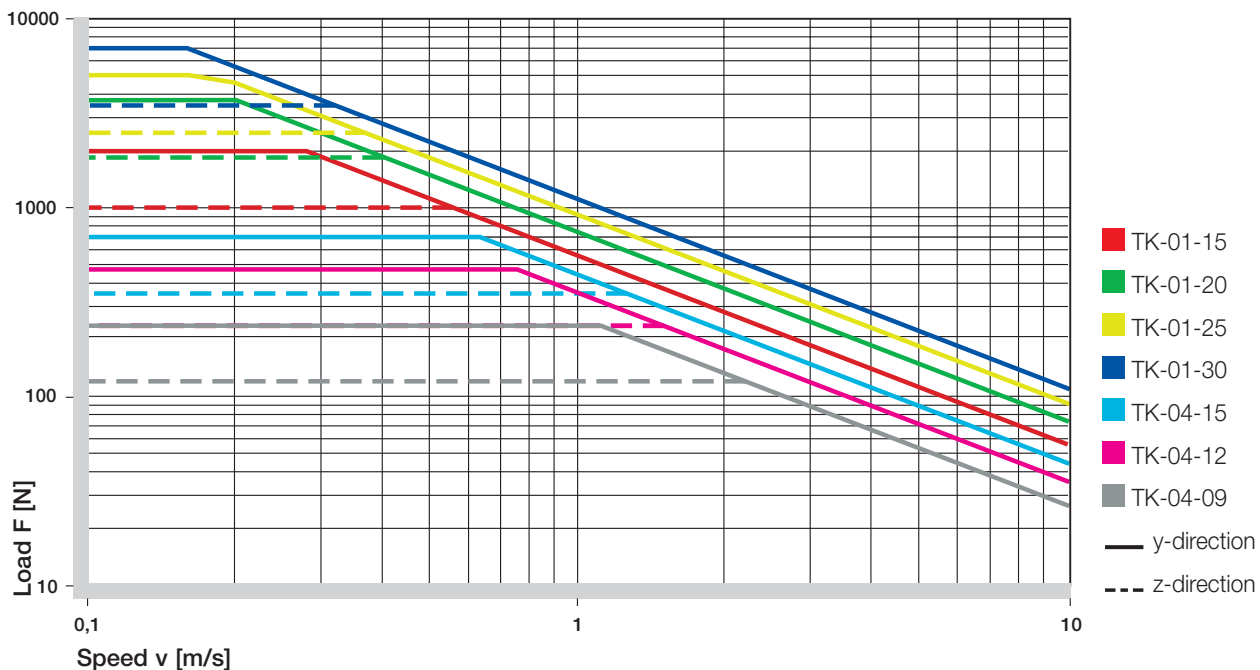

Graph 61.2: DryLin® T – Permissible dynamic load

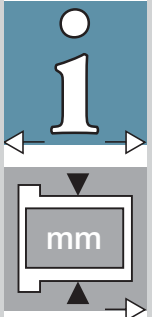

DryLin® T | Adjusting and Installation



Installation notes

When designing systems with 2 parallel rails, one side must be used with floating bearings. For each orientation, there is a recommended fixed floating bearing solution. This installation method prevents binding or a locking of the guide when there are parallelism errors between the rails.

The floating bearing is created by the removal of the static sliding elements. The maximum compensation of parallelism errors between the mounted rails is 0.5 mm. In the installation, care must be taken that the floating bearing has equal play in both directions. You can see our recommended design of the fixed floating bearing system in the adjacent drawings.

The mounting surfaces for the rails and guide carriages should have a very flat surface (e.g. machined face), in order to prevent binding in the system. Variations in the mating surfaces can also be compensated up to a certain amount (0.5 mm) by a larger adjusted clearance. The clearance adjustment is only effective without load.

Please contact our technical experts if you have any questions on the engineering design and/or installation.

Floating bearings for linear slides

In the case of a system with two parallel guides, one side needs to be configured with floating bearings.

A suitable solution comprising fixed & floating bearings is available for every orientation, whether horizontal, vertical or lateral. This type of assembly prevents jamming and blockage on the guides resulting from discrepancies in parallelism. Floating bearings are created through a controlled extension of play in the direction of the expected parallelism error. This creates an additional degree of freedom on one side. During assembly, it must be ensured that the floating bearings exhibit a similar degree of play in both directions. The systems of fixed & floating bearings we recommend are shown in various related chapters.

The mating surfaces on the rails and carriages should be very flat (for instance, milled down) to prevent strains from occurring in the system.

Eccentric Forces

To ensure successful use of maintenance-free DryLin® linear bearings, it is necessary to follow certain recommendations:

If the distance between the driving force point and the fixed bearings is more than twice the bearing spacing (2:1 rule), a static friction value of 0.25 can theoretically result in jamming on the guides. This principle applies regardless of the value of the load or drive force.

The friction product is always related to the fixed bearings. The greater the distance between the drive and guide bearings, the higher the degree of wear and required drive force.

Failure to observe the 2:1 rule during use of linear plain bearings can result in uneven motion or even system seizure. Such situations can often be remedied with relatively simple modifications.

If you have any questions on design and/or assembly, please contact our application engineers.

- 1 Rail
- 2 Sliding elements
- 3 Fixed bearing
- 4 Floating bearing LLZ or LLY

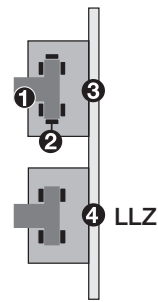

Lateral/vertical installation with floating bearing in the z-direction

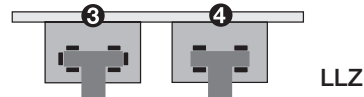

Horizontal installation with floating bearing in the z-direction

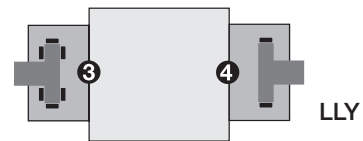

Horizontal installation with lateral carriages, with floating bearing in the y-direction

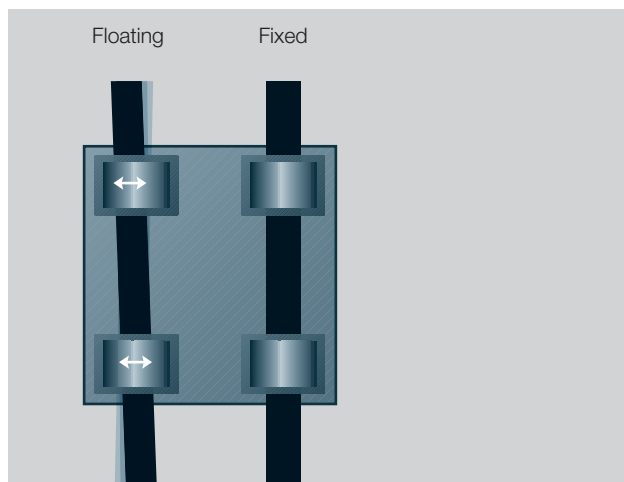

Automatic compensation of parallelism errors

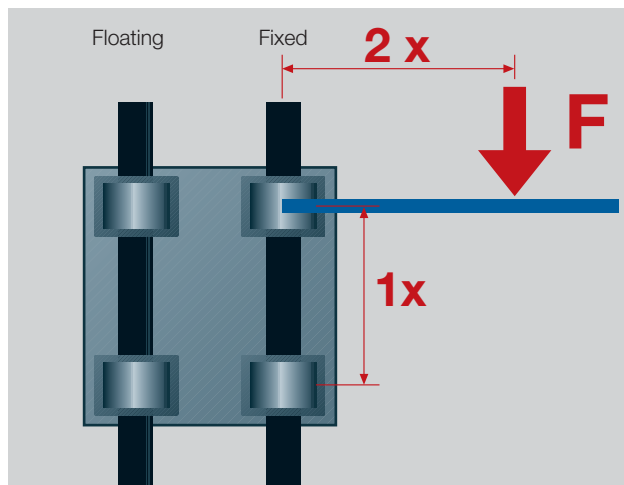

The 2:1 Rule

DryLin® T

Phone +44 (0) 1604 - 67 72 40
Fax +44 (0) 1604 - 67 72 45





DryLin® TK-01... | Adjustable clearance | mm

DryLin® T

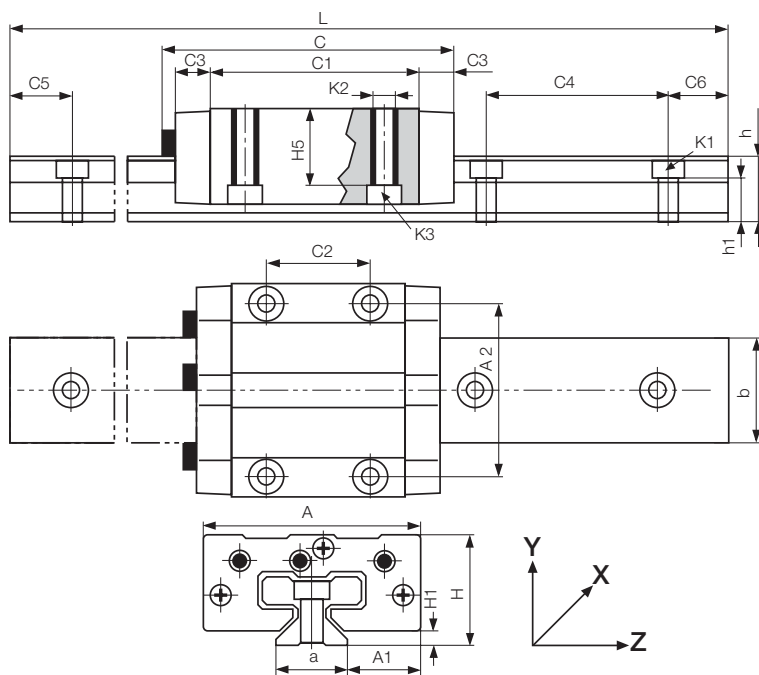

- Slide carriage with manual adjustable clearance
- Maintenance-free, dry operation
- Resistant to corrosion
- Hard anodized aluminium rails
- Standard bore pattern symmetrical C5 = C6

Phone +44 (0) 1604 - 677240
Fax +44 (0) 1604 - 677245

DryLin® T Guide Rails

Part No.	Weight [kg/m]	L [mm]	a [mm]	C4 [mm]	C5		C6		h [mm]	h1 [mm]	K1 for Screw DIN 912 [mm]	b [mm]	ly [mm ²]	lz [mm ²]	Wby [mm ³]	Wbz [mm ³]
					Max.	Min.	Max.	Min.								
TS-01-15	0,6	4000	15	60	20	49	20	49	15,5	10,0	M 4	22	6440	4290	585	488
TS-01-20	1,0	4000	20	60	20	49	20	49	19,0	12,3	M 5	31	22570	11520	1456	1067
TS-01-25	1,3	4000	23	60	20	49	20	49	21,5	13,8	M 6	34	34700	19300	2041	1608
TS-01-30	1,9	4000	28	80	20	59	20	59	26,0	15,8	M 8	40	70040	40780	3502	2832

Order example: TS-01-15, 2000 for a guide rail TS-01-15 of 2 m length
For rails without mounting holes, please use part number suffix "without mounting hole"

igus® UK Ltd

DryLin® T Guide Carriages

Part No.	Weight [kg]	H [mm]	A [mm]	C [mm]	A1		C1 [mm]	C2 [mm]	C3 [mm]	H1 [mm]	H5 [mm]	K2 Thread	Torque Max. [Nm]	K3 for Screw DIN 912
					±0,35	±0,35								
TW-01-15	0,11	24	47	74	16,0	38	50	30	9	4,0	16,0	M 5	1,5	M 4
TW-01-20	0,19	30	63	87	21,5	53	61	40	10	5,0	19,8	M 6	2,5	M 5
TW-01-25	0,29	36	70	96	23,5	57	68	45	11	5,0	24,8	M 8	6,0	M 6
TW-01-30	0,50	42	90	109	31,0	72	79	52	12	6,5	27,0	M 10	15,0	M 8

Order examples: TW-01-20 for a guide carriage
TW-01-20, LLy for a guide carriage with floating bearing in y-direction
TW-01-20, LLz for a guide carriage with floating bearing in z-direction

DryLin® TK-01 Complete System



Structure – part no.

TK	-01	-15	-2	,500
----	-----	-----	----	------

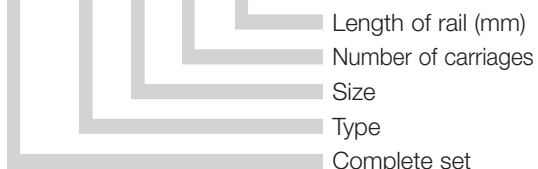

This order example (TK-01-15-2, 500) corresponds to a complete DryLin® system of size 15 with 2 carriages and 500 mm rail length.

Order TK-01-15-2, 500, LLy for a complete system with floating bearing in y-direction.

Internet www.igus.co.uk
E-mail sales_uk@igus.co.uk

DryLin® T | Adjusting and Installation



Adjusting the clearance: DryLin® T

DryLin® T is delivered ready for installation. Clearance of the carriage is adjusted at the factory. The preadjustment is determined by the acting forces on each individual system. If you have special requirements, please indicate in your order whether particularly limited or extended bearing clearance is required. If necessary, clearance of the DryLin® T linear guide system can be readjusted. This should always take place when there is no load on the carriage.

1 After removing the protective cover, loosen the locknuts – Width across flats:

- SW 5 for TW-01-15 and TW-01-20
- SW 7 for TW-01-25 and TW-01-30

2 Adjust the bearing clearance for the 3 guide points with an Allen key – Allen key size:

- 1.5 mm for TW-01-15 and TW-01-20
- 2.0 mm for TW-01-25 and TW-01-30

3 Check the clearance of the carriage after adjusting the 3 levels. If it is sufficient, tighten the locknuts and put on the cover.

4 There is a danger that excessive reduction of the clearances can seize the sliding pads and that the clearance cannot be reset simply by loosening the adjustment screws. The sliding pads are then released by pressing the reset button on the opposite side. Press hard against the readjusting spring. You must have already loosened the respective adjustment screws. Use the correct size pin for this purpose:

- 2.5 mm for TW-01-20 and TW-01-15
- 3.0 mm for TW-01-25 and TW-01-30

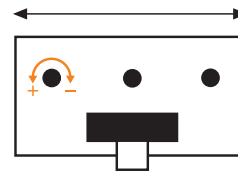

lateral guide:

- less clearance
- + more clearance

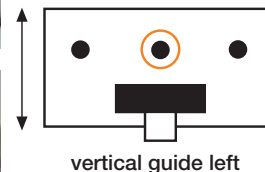

vertical guide left

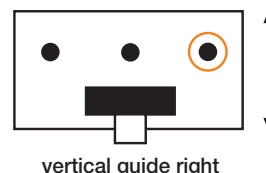

vertical guide right

Adjusting the clearance: DryLin® T Automatic

The DryLin® T Automatic series offers you an automatic adjustment of the clearance. A readjustment can take place automatically in steps of 0.1 mm. Springs tighten the regulating wedge immediately as soon as the clearance is bigger than 0.1 mm and the system is unloaded.

1 The system will be delivered with 3 keys which are already fitted. They are necessary for mounting the carriage onto the rail. In case these keys are removed they need to be replugged into the openings and turned clockwise 90°.

2 When the carriage is on the rail, remove the keys by turning them anticlockwise 90° and pull out. The clearance will then be adjusted automatically.

3 Check the clearance of the carriage. Fine adjusting can be done at this point.

4 You can remove the carriage at any time. In order to do so, simply plug the keys back into the carriage (see step 1).

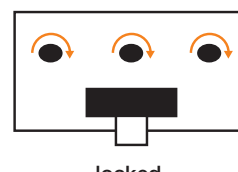

locked

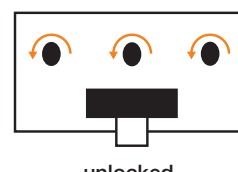

unlocked

DryLin® T

Phone +44 (0) 1604 - 67 72 40
Fax +44 (0) 1604 - 67 72 45

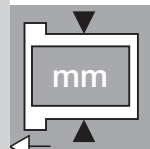



DryLin® T | System Design

For the exact calculation of the DryLin® T Linear Guide System it is essential to find out whether the position of the forces is within the allowable limits, and if the sliding pad where the highest forces occur is not overloaded.

The calculation of the necessary driving force and the maximum permissible speed is important. Each orientation requires a different formula for calculation.

Please note that it is often easier to visit the igus® website and input all the application data online, then the expert system will do these calculations for you. Alternatively (and easier still) contact igus®, and have all the work done for you, free of charge and without obligation.

Please note that the following calculations do not contain any guarantees with regard to impact loads and acceleration forces. The drive should always take place precisely in the x direction, as additional loads and increased drive resistances (danger of seizing) occur (for e.g. in crank drive) that cannot be neglected.

If your application uses a crank drive or similar, please consult your igus® contact who can perform an advanced calculation for you.

Variables in the calculations:

- Fa** : Drive Force [N]
- Fs** : Applied Mass [N]
- Fy, Fz** : Bearing Load [N]
in y- or z-direction [mm]
- sx, sy, sz** : Location of the centre of gravity in x-, y- or z-direction [mm]
- ay, az** : Location of the driving force in y- or z-direction [mm]
- wx** : Distance between carriages on a rail [mm]
- LX** : Constant from table below [mm]
- Zm** : Constant from table below [mm]
- Y0** : Constant from table below [mm]
- b** : Distance between guide rails [mm]
- μ** : Coefficient of friction,
μ = 0 for static loads,
μ = 0.2 for dynamic loads
- ZW** : Number of carriages per rail

The constant values:

Part No.	Lx [mm]	Zm [mm]	Y0 [mm]
TW-01-15	29	16	11,5
TW-01-20	35	23	15,0
TW-01-25	41	25	19,0
TW-01-30	49	29	21,5

Recommended procedure: 1st step:

Select the orientation

- **horizontal**
 - 1 rail and 1 carriage ► Page 61.14
 - 1 rail and 2 carriages ► Page 61.14
 - 2 rails and 4 carriages ► Page 61.14
- **lateral**
 - 1 rail and 1 carriage ► Page 61.15
 - 1 rail and 2 carriages ► Page 61.15
 - 2 rails and 4 carriages ► Page 61.15
- **vertical**
 - 1 rail and 1 carriage ► Page 61.16
 - 1 rail and 2 carriages ► Page 61.16
 - 2 rails and 4 carriages ► Page 61.16

2nd step:

Check to see whether the offset distances of the applied forces are within the permissible values
► Pages 61.14 to 61.16

3rd step:

Calculate the necessary drive force
► Page 61.14 to 61.16

4th step:

Calculate the maximum bearing load in y- and z-directions
► Page 61.14 to 61.16

5th step:

Check out the maximum bearing load of the most strongly affected bearing with the load calculated in step No. 4.
► Page 61.13, table 61.2

6th step:

Determination of the maximum permitted speed for the load from step No. 4.
► Page 61.13, Graph. 61.3

Coefficients:

	1 rail, 1 carriage	1 rail, 2 carriages	2 rails, 3-4 carriages
K₁	$ (ay+Y0)/Lx $	$ (ay+Y0)/Wx $	$ (ay+Y0)/Wx $
K₂	$(sy+Y0)/Lx$	$(sy+Y0)/Wx$	$(sy+Y0)/Wx$
K₃	$laz/Lx $	$laz/Wx $	$laz/Wx $
K₄	$lsx/Lx $	$lsx/Wx $	$lsx/Wx $
K₅	sz/Lx	$sz/Wx $	$sz/Wx $
K₆	$ (sy+Y0)/Zm $	$ (sy+Y0)/Zm $	$ (sy+Y0)/b $
K₇	$lsz/Zm $	$lsz/Zm $	$ (sz/b)-0,5 $

DryLin® T

Phone +44 (0) 1604 - 67 72 40
Fax +44 (0) 1604 - 67 72 45

igus® UK Ltd

Internet www.igus.co.uk
E-mail sales_uk@igus.co.uk

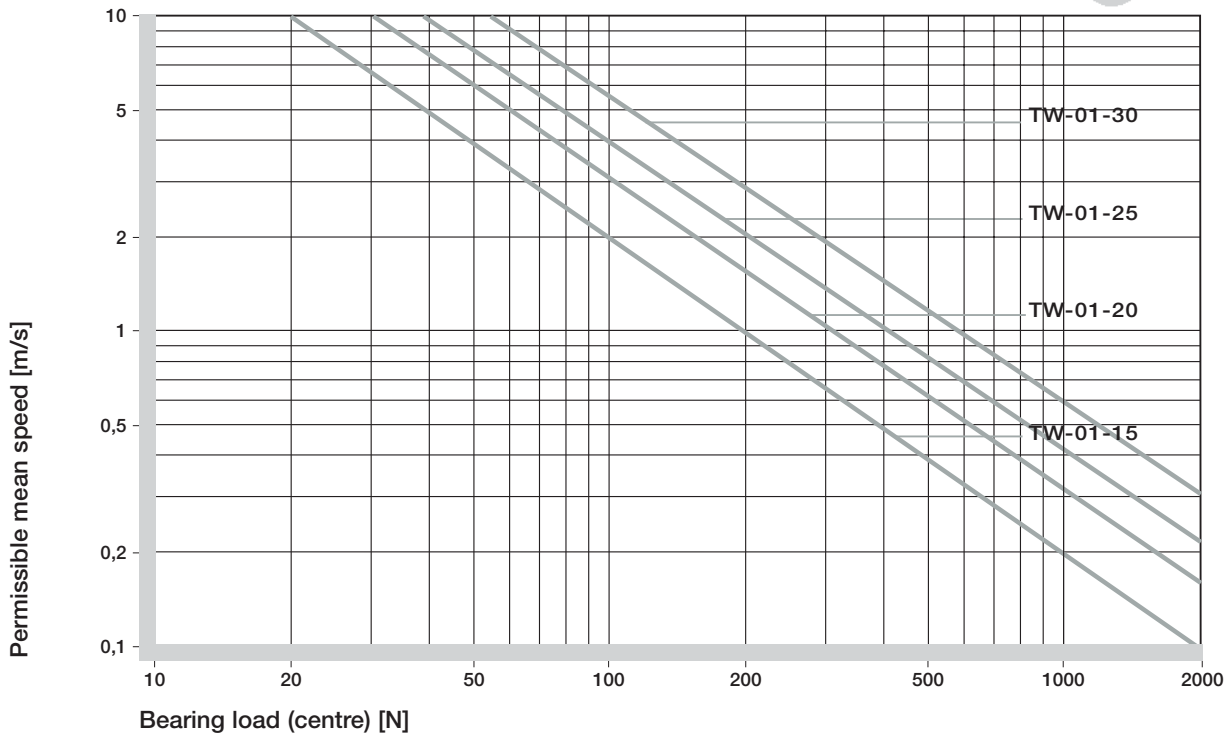

Graph 61.3: Graph to determine the maximum permissible speed for the calculated bearing load

Part No.	F _y max, F _z max [N]
TW-01-15	2000
TW-01-20	3700
TW-01-25	5000
TW-01-30	7000

Table 61.2: Maximum permissible load



DryLin® T linear guide systems are used in these enveloping machines to guide a suction opener for envelopes. The guide system must have low clearance, be maintenance-free and not require any lubrication.

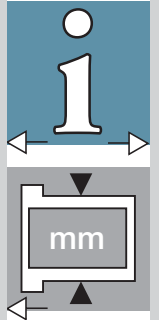



DryLin® T Orientation: Horizontal

Maximum permissible distances between applied forces:

Variation: 1 rail, 1 carriage

$s_y + s_z$	<	$2 L_x - Y_0$
$a_y + a_z$	<	$2 L_x - Y_0$
s_y	<	$5 Z_m$
s_z	<	$5 Z_m$

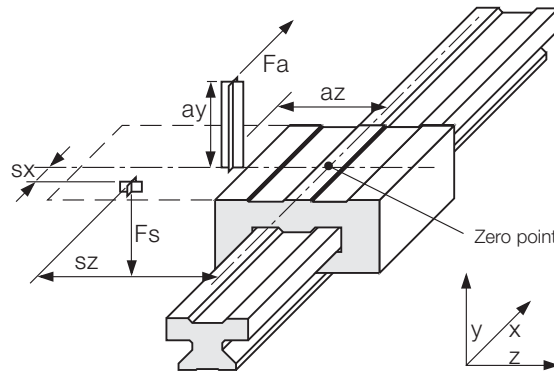

Maximum permissible distances between applied forces:

Variation: 1 rail, 2 carriages

Variation: 2 rails, 4 carriages

$s_y + s_z$	<	$2 w_x - Y_0$
$a_y + a_z$	<	$2 w_x - Y_0$

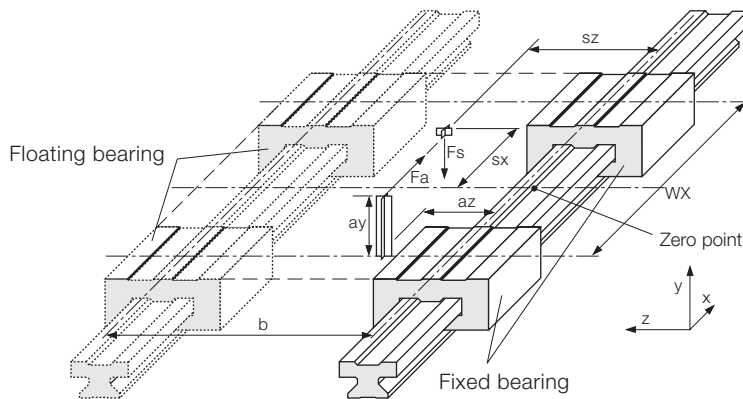

2nd step:

Check to see whether the maximum distances of the applied forces are within the permissible values. (See maximum permissible distances)

3rd step:

Calculate the necessary drive force

- 3.1 Centre of gravity in **x- and z-direction** inside the carriage(s)

$$F_{a1} = \frac{\mu}{1 - 2\mu K_3} \cdot F_s$$

- 3.2 Centre of gravity in **z-direction** outside of the carriage(s)

$$F_{a2} = \frac{2\mu K_7}{1 - 2\mu K_3} \cdot F_s$$

- 3.3 Centre of gravity in **x-direction** outside of the carriage(s)

$$F_{a3} = \frac{2\mu K_4}{1 - 2\mu K_3 - 2\mu K_1} \cdot F_s$$

If the position of the centre of gravity is not specified:

$$F_a = \text{MAX} (F_{a1}, F_{a2}, F_{a3})$$

4th step:

Calculate the maximum bearing load

- 4.1 Maximum bearing load in **y-direction**

$$F_{y\text{max}} = \frac{2F_s}{Z_w} \left(\frac{2K_4}{Z_w} + 0.5 \right) \cdot \left(K_7 + 0.5 \right) + \frac{2F_a K_1}{Z_w^2}$$

- 4.2 Maximum bearing load in **z-direction**

$$F_{z\text{max}} = \frac{4F_a K_3}{Z_w^2}$$

DryLin® T

Phone +44 (0) 1604 - 677240
Fax +44 (0) 1604 - 677245

igus® UK Ltd

Internet www.igus.co.uk
E-mail sales_uk@igus.co.uk



2nd step:

Check to see whether the maximum distances of the applied forces are within the permissible values. (See maximum permissible distances)

3rd step:

Calculate the necessary drive force

First two calculations must be made:

$$Fa1 = \frac{(1+2K_6)\mu}{1-2\mu K_1} \cdot Fs$$

$$Fa2 = \frac{(2K_4+2K_6)\mu}{1-2\mu K_1-2\mu K_3} \cdot Fs$$

The drive force Fa corresponds to the calculated maximum value:

$$Fa = \text{MAX} (Fa1, Fa2)$$

4th step:

Calculate the maximum bearing load

4.1 Maximum bearing load in y-direction

$$F_{y\max} = \frac{Fs K_6}{Zw} + \frac{2Fa K_1}{Zw^2}$$

4.2 Maximum bearing load in z-direction

$$F_{z\max} = \frac{2Fs}{Zw} \left(\frac{2K_4}{Zw} + 0.5 \right) + \frac{4Fa K_3}{Zw^2}$$

Maximum permissible distances between applied forces:

Variation: 1 rail, 1 carriage		
$sy + sz$	$<$	$2 Lx - Y_0$
$ay + az$	$<$	$2 Lx - Y_0$
sy	$<$	$5 Zm$
sz	$<$	$5 Zm$

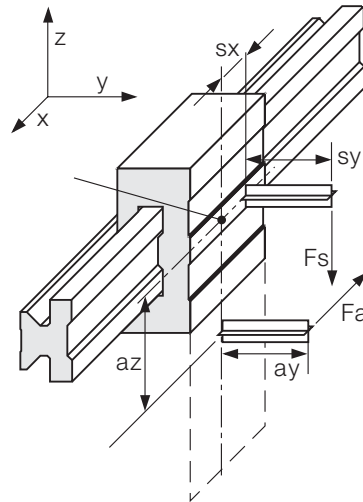

Maximum permissible distances between applied forces:

Variation: 1 rail, 2 carriages		
Variation: 2 rail, 4 carriages		
$sy + sz$	$<$	$2 wx - Y_0$
$ay + az$	$<$	$2 wx - Y_0$

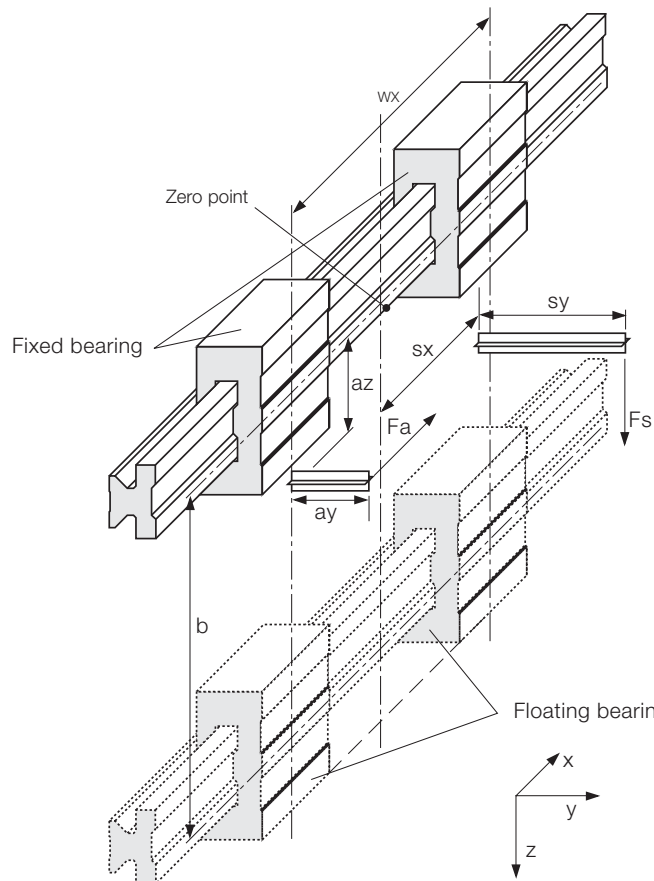

DryLin® T

Phone +44 (0) 1604 - 67 72 40
Fax +44 (0) 1604 - 67 72 45





DryLin® T Orientation: Vertical

Maximum permissible distances between applied forces:

Variation: 1 rail, 1 carriage

$s_y + s_z$	$<$	$2 L_x - Y_0$
$a_y + a_z$	$<$	$2 L_x - Y_0$
s_y	$<$	$5 Z_m$
s_z	$<$	$5 Z_m$

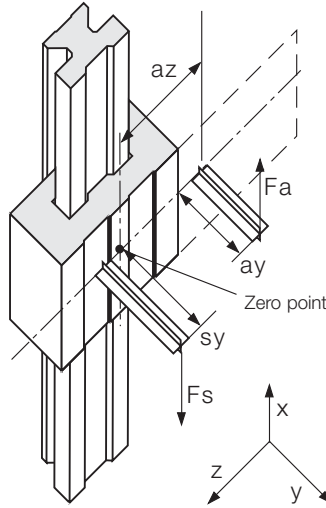

Maximum permissible offset distances between applied forces:

Variation: 1 rail, 2 carriages

Variation: 2 rails, 4 carriages

$s_y + s_z$	$<$	$2 w_x - Y_0$
$a_y + a_z$	$<$	$2 w_x - Y_0$

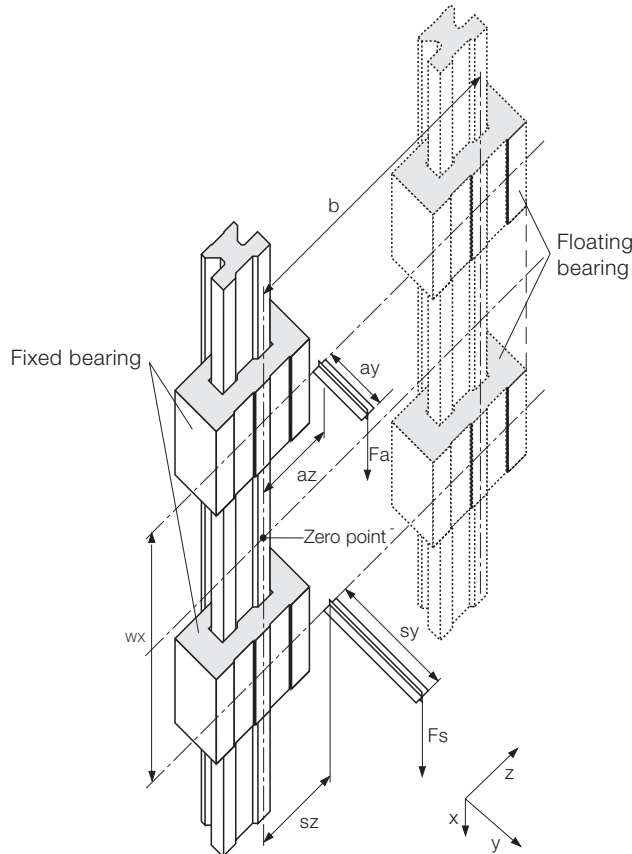

2nd step:

Check to see whether the maximum distances of the applied forces are within the permissible values. (See maximum permissible distances)

3th step:

Calculate the necessary drive force

First, four calculations must be made:

$$F_{a1} = \frac{2\mu (s_z + s_y + Y_0) - w_x}{2\mu (a_z + a_y + Y_0) - w_x} \cdot F_s$$

$$F_{a2} = \frac{2\mu (-s_z + s_y + Y_0) - w_x}{2\mu (-a_z + a_y + Y_0) - w_x} \cdot F_s$$

$$F_{a3} = \frac{2\mu (s_z - s_y - Y_0) - w_x}{2\mu (a_z - a_y - Y_0) - w_x} \cdot F_s$$

$$F_{a4} = \frac{2\mu (s_z + s_y + Y_0) + w_x}{2\mu (a_z + a_y + Y_0) + w_x} \cdot F_s$$

The drive force F_a corresponds to the calculated maximum value:

$$F_a = \text{MAX} (F_{a1}, F_{a2}, F_{a3}, F_{a4})$$

4th step:

Calculate the maximum bearing load

4.1 Maximum bearing load in **y-direction**

$$F_{y\text{max}} = \left| F_a \frac{a_y + Y_0}{w_x} - F_s K_2 \right| \cdot \frac{2}{Z_w^2}$$

4.2 Maximum bearing load in **z-direction**

$$F_{z\text{max}} = \left| F_a \frac{a_z}{w_x} - F_s K_5 \right| \cdot \frac{4}{Z_w^2}$$

DryLin® T

Phone +44 (0) 1604 - 677240
Fax +44 (0) 1604 - 677245

igus® UK Ltd

Internet www.igus.co.uk
E-mail sales_uk@igus.co.uk